

catalogo generale

eco**materiali**



CASALGRANDE
PADANA
Pave your way

INDICE INDEX

INDICE PER EFFETTO INDEX BY EFFECT **03**
INDEX PAR EFFET **INDEX DURCH WIRKUNG**

INDICE PER LINEA INDEX BY LINE **04**
INDEX PAR LIGNE **INDEX FÜR ZEILE**

INDICE PER SERIE INDEX BY SERIES **05**
INDEX PAR SÉRIE **INDEX NACH SERIE**

INDICE PER FORMATO INDEX BY FORMAT **06**
PAR FORMAT **NACH FORMAT**

INDICE PER ARTICOLO INDEX BY ARTICLE **09**
INDEX PAR ARTICLE **INDEX NACH ARTIKEL**

INDICE PER EFFETTO INDEX BY EFFECT INDEX PAR EFFET INDEX DURCH WIRKUNG

ECObios	14	ECOmarmo	176	ECOcolore	342
Bios ceramics	16	Marmoker	180	Earth	346
Bios self-cleaning	18	Marte	208	Architecture	354
Bios antibacterial	28	Onici	222	Unicolore	366
				Caleidoscopio	374
ECOpetra	40	ECOMETALLO	226	Elementi	382
Pietre di paragone	44	Metallica	230	Landscape	388
Amazzonia	56	Steeltech	238		
Chalon	62			ECOCemento	394
Limestone	68	ECOLEGNO	244	Manhattan	398
Meteor	74	Antique wood	248	R-evolution	404
Mineral chrom	82	Country wood	254	Beton	410
Pietra baugé	88	Class wood	260	Cemento	422
Pietre di Sardegna	94	Geowood	264	Resina	432
Stonewash	106	Tavolato	268	Spazio	440
Terre toscane	112	Planks	274	Econcrete	446
Pietre etrusche	120	Limpha	278	Opus	450
Basaltina	128	Ulivo	284	Città	460
Pietra blue	138	Newood	290	Feel	464
Pietra piacentina	142	Metalwood	298	Living	468
Kerblock	146	Parchi	304		
Natural slate	150			ECOTecnico	472
Titano	154	ECOgranito	308	Technic	476
Ardesia	160	Granito 1Evo	312	Tactile	486
Lavagna	164	Granito 1	316		
Patio	168	Granito 2	324	ECOutility	490
Agorà	172	Granito 3	330		
		Granito 4	336		

INDICE PER LINEA INDEX BY LINE INDEX PAR LIGNE INDEX FÜR ZEILE

GRANITOGRES	Agorà	172
	Architecture	354
	Ardesia	160
	Elementi	382
	Granito 1	316
	Granito 1Evo	312
	Granito 2	324
	Granito 3	330
	Granito 4	336
	Marte	208
	Natural slate	150
	Tactile	486
	Technic	476
	Titano	154
	Unicolore	366

PIETRE NATIVE	Amazzonia	56
	Basaltina	128
	Chalon	62
	Kerblock	146
	Lavagna	164
	Limestone	68
	Meteor	74
	Mineral chrom	82
	Pietra baugé	88
	Pietra blue	138
	Pietra piacentina	142
	Pietre di paragone	44
	Pietre di Sardegna	94
	Pietre etrusche	120
	Spazio	440
	Terre toscane	112

GRANITOKER	Antique wood	248
	Beton	410
	Cemento	422
	Class wood	260
	Country Wood	254
	Earth	346
	Geowood	264
	Limpha	278
	Manhattan	398
	Marmoker	180
	Metallica	230
	Metalwood	298
	Newood	290
	Onici	222
	Opus	450
	Planks	274
	R-evolution	404
	Resina	432
	Steeltech	238
	Stonewash	106
	Tavolato	268
	Ulivo	284

GREPLUS	Città	460
	Econcrete	446
	Landscape	388
	Parchi	304
	Patio	168

ECOGRES	Caleidoscopio	374
	Feel	464
	Living	468

INDICE PER SERIE INDEX BY SERIES INDEX PAR SÉRIE INDEX NACH SERIE

Agorà	Granitogres	172	Marte	Granitogres	208
Amazzonia	Pietre native	56	Metallica	Granitoker	230
Antique wood	Granitoker	248	Metalwood	Granitoker	298
Architecture	Granitogres	354	Meteor	Pietre native	74
Ardesia	Granitogres	160	Mineral chrom	Pietre native	82
Basaltina	Pietre native	128	Natural slate	Granitogres	150
Beton	Granitoker	410	Newood	Granitoker	290
Caleidoscopio	Ecogres	374	Onici	Granitoker	222
Cemento	Granitoker	422	Opus	Granitoker	450
Chalon	Pietre native	62	Parchi	Gresplus	304
Città	Gresplus	460	Patio	Gresplus	168
Class wood	Granitoker	360	Pietra baugé	Pietre native	88
Country Wood	Granitoker	254	Pietra blue	Pietre native	138
Earth	Granitoker	346	Pietra piacentina	Pietre native	142
Econcrete	Gresplus	446	Pietre di paragone	Pietre native	44
Elementi	Granitogres	382	Pietre di Sardegna	Pietre native	94
Feel	Ecogres	464	Pietre etrusche	Pietre native	120
Geowood	Granitoker	264	Planks	Granitoker	274
Granito 1	Granitogres	316	R-evolution	Granitoker	404
Granito 1Evo	Granitogres	312	Resina	Granitoker	432
Granito 2	Granitogres	324	Spazio	Pietre Native	440
Granito 3	Granitogres	330	Steeltech	Granitoker	238
Granito 4	Granitogres	336	Stonewash	Granitoker	106
Limpha	Granitoker	278	Tactile	Granitogres	486
Kerblock	Pietre native	146	Tavolato	Granitoker	268
Landscape	Gresplus	388	Technic	Granitogres	476
Lavagna	Pietre native	164	Terre toscane	Pietre native	112
Limestone	Pietre native	68	Titano	Granitogres	154
Living	Ecogres	468	Ulivo	Granitoker	284
Manhattan	Granitoker	398	Unicolore	Granitogres	366
Marmoker	Granitoker	180			

INDICE PER FORMATO INDEX BY SIZE PAR FORMAT NACH FORMAT

cm 160x320

Marmoker	180
Pietre di Paragone	44
Pietre di Sardegna	94

cm 120x260

Cemento	422
Pietre di Paragone	44
Pietre di Sardegna	94

cm 118x258

Marmoker	180
Onici	222

cm 120x240

Cemento	422
Pietre di Paragone	44
Pietre di Sardegna	94

cm 118x236

Marmoker	180
Onici	222

cm 30x240

Planks	274
--------	-----

cm 20x240

Planks	274
--------	-----

cm 120x120

Cemento	422
Pietre di Paragone	44
Pietre di Sardegna	94
Terre Toscane	112

cm 118x118

Marmoker	180
Onici	222

cm 60x120

Antique Wood	248
Architecture	354
Basaltina	128
Cemento	422
Chalon	62
Earth	346
Marte	208
Metalwood	298
Newood	290
Pietre di Paragone	44
Pietre di Sardegna	94
Pietre Etrusche	120
R-evolution	404
Steeltech	238
Tavolato	268
Terre Toscane	112
Ulivo	284
Unicolore	366

cm 59x118

Marmoker	180
Onici	222

cm 40x120

Country Wood	254
--------------	-----

cm 30x120

Earth	346
Planks	274
Stonewash	106
Tavolato	268
Ulivo	284

cm 29,5x118

Marmoker	180
----------	-----

cm 20x120

Antique Wood	248
Class Wood	260
Country Wood	254
Marte	208
Metalwood	298
Newood	290
Planks	274
Stonewash	106
Tavolato	268
Ulivo	284

cm 15x120

Antique Wood	248
Earth	346
Metalwood	298
Newood	290
Tavolato	268
Ulivo	284

cm 90x180

Marmoker	180
Pietre di Paragone	44
Resina	432
Stonewash	106

cm 45x180

Stonewash	106
-----------	-----

cm 30x180

Stonewash	106
-----------	-----

cm 22,5x180

Class Wood	260
Geowood	264
Stonewash	106

cm 90x90

Architecture	354
Manhattan	398
Marmoker	180
Pietre di Paragone	44
Pietre di Sardegna	94
Resina	432
Steeltech	238
Stonewash	106
Marmoker	180

cm 45x90

Amazzonia	56
Architecture	354
Basaltina	128
Manhattan	398
Marmoker	180
Metalwood	298
Newood	290
Pietre di Paragone	44
Pietre di Sardegna	94
Pietre Etrusche	120
Resina	432
Steeltech	238
Terre Toscane	112

cm 22,5x90

Newood	290
--------	-----

cm 15x90

Architecture	354
Metalwood	298
Newood	290
Tavolato	268

cm 11x90

Newood	290
--------	-----

cm 45x45

Amazzonia	56
Basaltina	128
Città	460
Econcrete	446
Granito 1evo	312
Meteor	74
Pietre di Sardegna	94
Pietre Etrusche	120
Spazio	440

cm 75,5x151

Beton	410
-------	-----

cm 25x151

Country Wood	254
--------------	-----

cm 75,5x75,5

Beton	410
Cemento	422
Spazio	440

cm 37,5x75,5

Beton	410
Cemento	422
Spazio	440

cm 60x60

Amazzonia	56
Architecture	354
Basaltina	128
Cemento	422
Chalon	62
Città	460
Earth	346
Granito 1evo	312
Granito 4	336
Kerblock	146
Lavagna	164
Limestone	68
Living	468
Manhattan	398
Marte	208
Metallica	230
Metalwood	298
Meteor	74
Mineral Chrom	82
Parchi	304
Pietra Baugé	88
Pietra Blue	138
Pietre di Paragone	44
Pietre di Sardegna	94
Pietre Etrusche	120
R-evolution	404
Spazio	440
Steeltech	238
Terre Toscane	112
Titano	154
Unicolore	366

cm 59x59

Marmoker	180
Onici	222

cm 30x60

Amazzonia	56
Architecture	354
Basaltina	128
Cemento	422
Chalon	62
Città	460
Earth	346
Feel	464
Granito 1evo	312
Granito 4	336
Lavagna	164
Limestone	68
Living	468
Manhattan	398
Marte	208
Metallica	230
Metalwood	298
Meteor	74
Mineral Chrom	82
Pietra Baugé	88
Pietra Blue	138
Pietra Piasentina	142
Pietre di Paragone	44
Pietre di Sardegna	94
Pietre Etrusche	120
R-evolution	404
Spazio	440
Steeltech	238
Terre Toscane	112
Titano	154
Unicolore	366

INDICE PER FORMATO INDEX BY FORMAT PAR FORMAT NACH FORMAT

cm 29,5x59

Marmoker **180**

cm 15x60

Architecture **354**

Marte **208**

Meteor **74**

Pietre di Sardegna **94**

Pietre Etrusche **120**

Tavolato **268**

cm 10x60

Marte **208**

Metalwood **298**

cm 9,8x59

Marmoker **180**

cm 30x30

Agorà **172**

Amazzonia **56**

Architecture **354**

Ardesia **160**

Basaltina **128**

Granito 1 **316**

Granito 1evo **312**

Granito 2 **324**

Granito 3 **330**

Lavagna **164**

Marte **208**

Meteor **74**

Natural Slate **150**

Pietre di Sardegna **94**

Pietre Etrusche **120**

Spazio **440**

Steeltech **238**

Terre Toscane **112**

Unicolore **366**

cm 15x30

Agorà **172**

Ardesia **160**

Mineral Chrom **82**

Natural Slate **150**

cm 15x15

Agorà **172**

Ardesia **160**

Granito 1 **316**

Lavagna **316**

Marte **208**

Meteor **74**

Mineral Chrom **82**

Natural Slate **150**

Pietre di Sardegna **94**

Pietre Etrusche **120**

cm 41,5x41,5

Feel **464**

Living **468**

Parchi **304**

cm 33x33

Caleidoscopio **374**

Feel **464**

Living **468**

cm 40x40

Granito 1 **316**

Marte **208**

Unicolore **366**

cm 20x40

Patio **168**

cm 20x20

Caleidoscopio **374**

Granito 1 **316**

Opus **450**

Patio **168**

Unicolore **366**

cm 10x20

Granito 1 **316**

Unicolore **366**

cm 25x25

Elementi **382**

Landscape **388**

cm 12,5x25

Granito 1 **316**

Unicolore **366**

Elementi **382**

Landscape **388**

cm 12,5x12,5

Elementi **382**

Landscape **388**

cm 6,5x25

Landscape **388**

INDICE PER ARTICOLO INDEX BY ARTICLE INDEX PAR ARTICLE INDEX NACH ARTIKEL

A

Acquamarina	369
Ajaccio	332
Alga 050	384
Amalfi	327
Amazique	266
Anice	377
Antique Black	250
Antique Moka	250
Antique White	250
Antracite	378
Arabesque	185
Arborea	280
Architecture Acid Green	360
Architecture Beige	359
Architecture Black	356
Architecture Cool Grey	356
Architecture Dark Brown	358
Architecture Dark Grey	356
Architecture Dark Ivory	358
Architecture Light Brown	358
Architecture Light Grey	356
Architecture Light Ivory	358
Architecture Medium Grey	357
Architecture Purple	360
Architecture Warm Grey	357
Architecture White	359
Ardesia Beige	162
Ardesia Bianco	162
Ardesia Grigio	162
Ardesia Nero	162
Ardesia Rosa	162
Ardesia Rosso	162
Ardesia Verde	162

Argento	300
Arizona	318
Arkansas	318
Artic 701	391
Asiago	187
Atene	462
Avorio	379
Avorio 011	384
Azul Bahia	212
Azul Macauba	212

B

Bahama 501	391
Baltic 201	391
Bardiglio Bianco	186
Bardiglio Imperiale	183
Basalto 061	385
Baugé Antracite	90
Baugé Beige	90
Baugé Bianca	90
Baugé Grigia	90
Bay 200	390
Beach 101	390
Berlino	462
Beton Dark	412
Beton Ivory	412
Beton Mud	412
Beton Pearl	412
Beton Sand	412
Betulla	379
Bianco Assoluto	369
Bianco Avorio	369
Bianco Avorio Tactile	488

Bianco B	369
Bianco Vietnam	186
Birimbau	183
Black Pearl	46
Blu	368
Blu Forte	368
Boston	314
Botticino	211
Breccia Argento	186
Breccia Carsica	182
Breccia Sarda	184
Bronzetto	210
Bronzo	300
Budapest	332
Budapest Tactile	488
Buxy	156

C

Caen	156
Caffè	376
Cala Luna	96
Canova	187
Capalbio	123
Caprera	96
Caramel	379
Carbonio	300
Cardoso	156
Caribe 500	390
Casablanca	333
Catalogna	320
Cemento 060	384
Cemento Cassero Antracite	424
Cemento Cassero Beige	424

INDICE PER ARTICOLO INDEX BY ARTICLE INDEX PAR ARTICLE INDEX NACH ARTIKEL

Cemento Cassero Bianco	425
Cemento Cassero Grigio	424
Cemento Rasato Antracite	424
Cemento Rasato Beige	424
Cemento Rasato Bianco	425
Cemento Rasato Grigio	424
Cervinia	327
Chalon Beige	64
Chalon Cream	64
Chalon Grey	64
Chalon Kaki	64
Chambrod	156
Champagne	157
Chicago	314
Cielo	377
Class Brown	262
Class Dove Grey	262
Class Grey	262
Class Walnut	262
Cobalto	377
Cocco	379
Colorado	320
Corallo	378
Corinto	174
Cortina	326
Country Bianco	256
Country Greige	256
Country Ice	256
Country Marrone	256
Country Tortora	256
Crema Marfil	211
Crema Select	185

D	
Dakota	318
Denver	314
Dragon Beige	59
Dragon Black	58
Dragon Brown	58
Dragon Chocolate	58
Dragon Green	58
Dragon Grey	58
Dragon White	59
Dune 300	391

E	
Earth Bianco	349
Earth Blu	348
Earth Brunello	348
Earth Grigio 1	349
Earth Grigio 2	349
Earth Grigio 3	348
Earth Grigio 4	348
Earth Metalred	348
Earth Tortora 1	349
Earth Tortora 2	349
Earth Tortora 3	349
EarthTortora 4	348
Ebano 070	385
Eco Antracite	448
Eco Beige	448
Eco Bianco	448
Eco Cenere	448
Eco Grigio	448
Elatea	174
Eldorado	58
Emperador	210
Everest	319

F	
Feel Beige	466
Feel Black	466
Feel Grey	466
Feel Olive	466
Feel Silver	466
Feel White	466
Ferro	232
Fiji	338
Fiorito	185
Fragola	379

G	
Gaiole	114
Gallipoli	327
Gelsomino	280
Genova	326
Georgia	319
Ghiaccio	378
Giallo Ocra	370
Giallo Ocra Tactile	488
Giallo Striato	184
Giamaica	318
Grafite	182
Granita	378
Gré Bianco	46
Gré Grigio	46
Gré Nero	47
Greve	114
Grigio Aitos	47
Grigio Ash	156
Grigio Azzurro	369
Grigio Billiemi	183
Grigio Cenere	368
Grigio Egeo	211

Grigio Maggia	210
Grigio Marostica	210
Grigio Perla	368
Grigio Tao	46
Groenlandia	338

H

Harlem	400
Hawaii	338
Helix	280
Helsinki	333

I

Iberia	320
Inox	232
Iridio	301
Iroko	266
Ischia	130
Islanda	338

J

Jolie	184
Jura Beige	48
Jura Grigia	48

K

Kerblock Avorio	148
Kerblock Beige	148
Kerblock Nero	148
Kerblock Piombo	148
Koa	266

L

Labrador	319
Lagoon 502	390
Lava 700	390
Lavagna Bianca	166
Lavagna Grigia	166
Lavagna Nera	166
Limestone Beige	70
Limestone Grigio	70
Limestone Nero	70
Linosa	130
Lipari	130
Liquirizia	376
Lisbona	463
Living Beige	470
Living Black	470
Living Brown	470
Living Grey	470
Living Ice	470
Living Noisette	470
Living White	470
Londra	482
Luni	48

M

Madagascar	338
Madras Pink	212
Madrid	332
Madrid Tactile	488
Manciano	122
Mare 021	385
Marina	377
Marocco	320
Matraia	156
Megalopoli	174
Menta	377
Meteor Almond	77
Meteor Beige	77
Meteor Bianco	77
Meteor Brown	76
Meteor Grafite	76
Meteor Grigio	76
Meteor Nero	76
Meteor Noce	76
Meteor Perla	77
Meteor Rosso	76
Milano	326
Mineral Beige	84
Mineral Black	84
Mineral Brown	84
Mineral Gold	84
Mineral Grey	84
Mineral White	84
Minnesota	319
Montepulciano	114
Monteriggioni	115
Montreal	332
Mosca	463

INDICE PER ARTICOLO INDEX BY ARTICLE INDEX PAR ARTICLE INDEX NACH ARTIKEL

N

Nebraska	319
Nero	368
Nero Acapulco	210
Nero Creta	182
Nevada	319
New Blue Brut	140
New Blue Moon	140
New York	314
Newood Beige	293
Newood Black	292
Newood Brown	292
Newood Cream	292
Newood Grey	292
Newood Ivory	293
Newood Wengè	292
Newood White	293

O

Ocean 202	391
Oceano	376
Ocra	378
Olimpo	186
Oliva	376
Onda 020	385
Onice Bianco	224
Onice Ghiaccio	224
Onice Miele	224
Onice Quarzo	224
Onice Striato	224
Onsernone	46
Ontario	318
Opus Beige	452
Opus Grigio	452

P

Pack	377
Paestum	123
Palissandro	211
Panna	379
Pantelleria	130
Patio Beige	170
Patio Black	170
Patio Brown	170
Patio Gold	170
Patio Grey	170
Patio White	170
Pevero	96
Piasentina	142
Pietra del Cardoso	46
Pietra di Vicenza	48
Pietra Piasentina New	48
Pino 051	384
Piombo	300
Pistacchio	376
Pitigliano	122
Planks Beige	276
Planks Bianco	276
Planks Bruno	276
Planks Grigio	276
Planks Muschio	276
Platino	301
Porto Cervo	97
Porto Rotondo	97
Praga	462
Pulpis Tortora	183
Punta Molara	96

Q

Queens	400
--------	-----

R

R-evolution Azure	407
R-evolution Black	406
R-evolution Blue	406
R-evolution Dark Grey	406
R-evolution Green	407
R-evolution Grey	407
R-evolution Light Pink	407
R-evolution Sand	406
R-evolution Terra	406
R-evolution Tortora	406
R-evolution Total White	407
R-evolution White	407
Raggio di Luna	211
Rame	232
Ramora Brown	210
Resina Black	434
Resina Grey	434
Resina Havana	434
Resina Tabacco	434
Resina White	434
Rosa Antico	370
Rosa Portogallo	212
Rosato	185
Rosso Mattone	370
Rosso Pompei	370
Rosso Selenio	378
Rotterdam	462

S

Sabbia 030	384
Sahara	318
Saint Laurent	182
San Casciano	115
San Gimignano	114
Santa fiora	122
Saturnia	123
Seattle	314
Sequoia	306
Shanghai	332
Shanghai Tactile	488
Siena	326
Silicio	300
Silvia Oro	185
Slate Beige	152
Slate Black	152
Slate Gold	152
Slate Green	152
Slate Grey	152
Slate Red	152
Smeraldo	376
Soho	400
Sovana	122
Sparta	174
Spazio Antracite	442
Spazio Argento	442
Spazio Beige	442
Spazio Bianco	443
Spazio Bronzo	442
Spazio Grigio	443
Spazio Perla	442
Spazio Tabacco	442
Spazio Tortora	442
Statuario Grigio	187

Statuario Oro	187
Steeltech Antracite	240
Steeltech Beige	240
Steeltech Corten	240
Steeltech Grigio	240
Stintino	96
Stoccolma	462
Stromboli	130
Sunset 400	391

T

Talco 010	384
Tarquinia	123
Tavolara	96
Tavolato Antracite	270
Tavolato Grano	270
Tavolato Marrone Chiaro	270
Tavolato Marrone Medio	270
Tavolato Marrone Scuro	270
Tavolato Sbiancato	270
Thassos	211
Tibet	320
Tokyo	332
Torino	326
Travertino Bianco	186
Travertino Miele	185
Travertino Moka	182
Travertino Noce	183
Travertino Romano	184
Travertino Santa Caterina	184
Travertino Titanium	183
Tribeca	400
Tucson	314
Tundra 100	390
Tuscania	122

U

Ulivo Grigio	286
Ulivo Noce	286
Ulivo Panna	286
Ulivo Tortora	286

V

Vals	48
Venezia	326
Verde	369
Verde Aver	184
Verde Guatemala	212
Verrazzano	114
Veselye	187
Violet	368
Volpaia	114
Vulcano	130
Vulci	122

W

Wash Brown	108
Wash Cream	108
Wash Grey	108
White Oak	266

Y

Yellowstone	306
-------------	-----

Z

ZebraWood	266
Zebrino	186
Zinco-Titanio	232



bios. ceramics®

CERAMICHE BIOATTIVE

Innovativa tipologia di prodotti eco-compatibili, in grado di interfacciarsi autonomamente con l'ambiente, per generare una serie di processi virtuosi, quali in particolare, reazioni di tipo chimico e biologico, capaci di ricadute positive in termini antibatterici, di abbattimento degli agenti inquinanti, di autopulibilità delle superfici e capaci di contribuire in maniera determinante all'innalzamento della qualità del microambiente (interno o esterno) in cui gli elementi ceramici vengono messi in opera. I processi avvengono grazie alla particolare natura dei materiali e dei trattamenti, senza alcuna necessità di alimentazione elettrica, energetica o del rinnovo dei composti necessari a sostenere nel tempo la reazione.

BIOACTIVE CERAMICS

Innovative kind of environment-friendly products that can independently interface with the environment to create a number of virtuous processes, such as chemical and biological reactions that have an air pollutant reducing and antibacterial effect and trigger the self-cleaning of the surfaces, thus remarkably contributing to improving the quality of the (internal or external) micro-environment in which the ceramics are installed. Such processes take naturally place thanks to the materials and treatments, without any electricity or energy, and without having to renew the compounds necessary to prolong the reaction.



Bios Ceramics®, è l'esclusiva generazione di ceramiche bioattive, certificate ed ecocompatibili, frutto di un master agreement siglato tra il Centro Ricerche **Casalgrande Padana** e **TOTO**, leader assoluto nel settore dei prodotti sanitari e pioniere nella tecnologia fotocatalitica a marchio *Hydrotect*.

La produzione si articola nell'ambito di due linee estremamente specializzate, in grado di rispondere a qualsiasi esigenza applicativa in interni ed esterni, associando al meglio, in funzione delle specifiche condizioni di impiego, caratteristiche antibatteriche, autopulenti e di riduzione degli agenti inquinanti. Una proposta trasversale e diversificata, che accanto alle eccellenti prestazioni garantite, permette di soddisfare la creatività di progettisti e clienti grazie alle ricercate finiture e ai diversi formati disponibili su tutta la gamma Casalgrande Padana.

L'OFFERTA COMPRENDE:

Bios Self-Cleaning®, pensata e sviluppata per la realizzazione di rivestimenti esterni di facciata. Grazie allo speciale trattamento basato sulla tecnologia *Hydrotect®*, in presenza di luce solare **Bios Self-Cleaning®** attiva una reazione in grado di abbattere non solo i batteri ma soprattutto gli inquinanti presenti nell'aria e decompone lo sporco che si deposita sulla superficie delle piastrelle, in modo che venga rimosso dall'acqua piovana, grazie alla superidrofilia della superficie ceramica.

Bios Antibacterial®, destinata alla realizzazione di pavimenti e rivestimenti con assolute proprietà antibatteriche, capace di abbattere al 99,9% i principali ceppi batterici presenti negli ambienti: *Escherichia coli*, *Pseudomonas aeruginosa*, *Staphylococcus aureus*, *Enterococcus faecalis*.

Bios Ceramics® is the exclusive range of certified eco-friendly bioactive ceramics resulting from a master agreement between the **Casalgrande Padana** Research Centre and **TOTO**, the world-leading sanitary ware manufacturer and pioneer in photocatalysis technology with its *Hydrotect* brand.

The range consists of two highly specialised series that meet any interior or exterior application requirement, associating antibacterial, self-cleaning, and pollutant reduction properties according to the specific conditions of use.

A cross-cutting and diversified range, which, in addition to its excellent performance guaranteed, gives free rein to designers' and customers' creativity, thanks to its refined finishes and different sizes available for the entire Casalgrande Padana range.

THE RANGE INCLUDES:

Bios Self-Cleaning® designed and developed for façade cladding. The special treatment based on the *Hydrotect®* technology allows **Bios Self-Cleaning®** to activate a reaction in the presence of sunlight. This reaction reduces air pollutants and decomposes dirt deposits, which are washed away by rainwater, thanks to the superhydrophilicity of the ceramic surface.

Bios Antibacterial®, intended for creating flooring and wall coverings with certified antibacterial properties, which can remove up to 99.9% of the main bacterial strains : *Escherichia coli*, *Pseudomonas aeruginosa*, *Staphylococcus aureus*, *Enterococcus faecalis*.



Bios Ceramics® est une nouvelle génération de céramiques bioactives certifiées et éco-compatibles, fruit de la collaboration entre le Centre de Recherches **Casalgrande Padana** et **TOTO**, leader absolu dans le secteur des produits sanitaires et pionnier dans la technologie photocatalytique, avec la marque *Hydrotect*.

Deux lignes ultra-spécialisées composent cette gamme en mesure de répondre à chaque exigence d'application, à l'extérieur comme à l'intérieur, en associant à la perfection des caractéristiques antibactériennes, autonettoyantes et d'élimination des agents polluants, en fonction des circonstances d'utilisation. Une offre transversale et diversifiée, qui permet, en plus de performances excellentes et garanties, de laisser libre cours à la créativité des concepteurs et des clients grâce à des finitions raffinées et les différents formats disponibles sur toute la gamme Casalgrande Padana.

ELLE COMPREND :

Bios Self-Cleaning®, conçue et développée pour la réalisation de revêtements extérieurs de façade. Grâce à un traitement spécial basé sur la technologie Hydrotect®, Bios self-cleaning® déclenche en présence de lumière solaire une réaction capable d'éliminer les polluants présents dans l'air, de décomposer les saletés déposées en surface et de les éliminer grâce à l'eau de pluie et aux propriétés ultra-hydrophiles de la surface céramique.

Bios Antibacterial®, destinée à la réalisation de sols et de revêtements dotés de propriétés antibactériennes élevées, permet d'éliminer 99,9 % des principales souches bactériennes présentes dans l'environnement: *Escherichia coli*, *Pseudomonas aeruginosa*, *Staphylococcus aureus*, *Enterococcus faecalis*.

Bios Ceramics® ist eine exklusive Generation an bioaktiven, zertifizierten und umweltfreundlichen Keramikprodukten – hervorgegangen aus einer Rahmenvereinbarung zwischen dem Forschungszentrum **Casalgrande Padana** und **TOTO**, dem absoluten Marktführer im Bereich von Gesundheitsprodukten und einem Pionier im Bereich der photokatalytischen Technologie mit dem Markenzeichen *Hydrotect*.

Die Produktion stützt sich auf zwei hochspezialisierte Anlagen, die jeder Anwendungsanforderung im Innen- und Außenbereich gerecht werden und dem Produkt je nach spezifischen Anwendungsbedingungen antibakterielle, selbstreinigende und schadstoffreduzierende Eigenschaften verleihen können. Ein transversales und vielfältiges Angebot, das es neben seinen hervorragenden und garantierten Eigenschaften möglich macht, die Kreativität von Planern und Kunden dank der ausgesuchten Oberflächenbearbeitungen und der unterschiedlichen Formate des Gesamtangebots von Casalgrande Padana zufrieden zu stellen.

DAS ANGEBOT UMFASST:

Bios Self-Cleaning®, konzipiert und entwickelt für den Bau von Fassaden-Außenverkleidungen. Dank der Spezialbehandlung auf Grundlage der HYDROTECT®-Technologie ruft Bios Self-Cleaning® im Sonnenlicht eine Reaktion hervor, die die vorhandene Luftverschmutzung bindet und den sich auf den Fliesenoberflächen absetzenden Schmutz zersetzt. Dieser kann dann in der Folge dank der super-hydrophilen Keramikoberfläche vom Regenwasser abgewaschen werden.

Bios Antibacterial®, konzipiert für das Verlegen von Bodenbelägen und Wandverkleidungen mit herausragenden antibakteriellen Eigenschaften, die bis zu 99,9 % der in geschlossenen Räumen auftretenden hauptsächlichsten Bakterienstämme abtöten können: *Escherichia coli*, *Pseudomonas aeruginosa*, *Staphylococcus aureus*, *Enterococcus faecalis*.

bios self-cleaning®

Una soluzione innovativa per i rivestimenti di facciata, in grado di qualificare gli involucri architettonici con elevate prestazioni di autopulizia e di abbattimento degli agenti inquinanti.

An innovative façade cladding solution that ensures high self-cleaning and pollution abatement performance for architectural envelopes.

Une solution innovante pour les revêtements de façade, en mesure de donner aux enveloppes architecturales d'excellentes performances d'autonettoyage et d'élimination des agents polluants.

Eine innovative Lösung für Fassadenverkleidungen, die Gebäudehüllen durch verbesserte selbstreinigende Eigenschaften und die Fähigkeit zum Abbau von Schadstoffen aufwertet.

PROPRIETÀ SUPER IDROFILE SUPER-HYDROPHILIC PROPERTIES PROPRIÉTÉ SUPER-HYDROPHILE SUPER HYDROPHILE EIGENSCHAFTEN

Lastra ceramica tradizionale
Traditional ceramic slab
Dalle céramique ordinaire
Traditionelle Keramikplatte

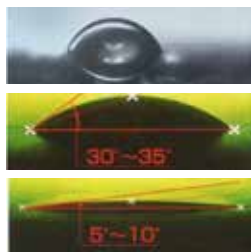

Lastra ceramica trattata
Bios Self-Cleaning®
Bios Self-Cleaning®
ceramic slab
Dalle céramique traitée
avec Bios Self-Cleaning®
Mit Bios Self-Cleaning®
behandelte Keramikplatte



unicolore bios bianco assoluto cm 10x60 - 4"x23⁵/₈"

LA TECNOLOGIA HYDROTECT®

La tecnologia **HYDROTECT®** viene utilizzata su licenza da oltre 100 produttori di tutto il mondo, nei più differenti settori applicativi, dall'industria automobilistica alle costruzioni. Detentore del brevetto è il gruppo giapponese TOTO, leader globale nel settore delle tecnologie fotocatalitiche, con il quale **Casalgrande Padana** ha sottoscritto un Master Agreement. Grazie a questa tecnologia le ceramiche **Bios Self-Cleaning®** utilizzate nei rivestimenti di facciata ed involucri ventilati, offrono significative risposte in termini di capacità autopulente e di abbattimento dei NOx (ossidi e miscele di azoto, tra i principali inquinanti dell'atmosfera urbana). In particolare, **Bios Self-Cleaning®** aggiunge alle caratteristiche estetiche e prestazionali dei rivestimenti ceramici in grès porcellanato, il drastico abbattimento degli interventi di pulizia e manutenzione delle superfici, garantendo un sensibile risparmio in termini economici e il mantenimento delle qualità e dell'aspetto del manufatto architettonico.

LE CARATTERISTICHE BIOATTIVE PER I RIVESTIMENTI ESTERNI

L'esclusiva formulazione di **Bios Self-Cleaning®** è a base di biossido di titanio (TiO₂), una sostanza naturale, non nociva, tradizionalmente utilizzata come pigmento bianco e per confezionare additivi alimentari, dentifrici, prodotti cosmetici eccetera.

Il biossido di titanio conferisce alle superfici **Bios Self-Cleaning®**:

- caratteristiche fotocatalitiche che, in presenza di irraggiamento luminoso, consentono di decomporre le sostanze organiche e gli inquinanti depositati sulle piastrelle, garantendo proprietà autopulenti e di purificazione dell'aria.
- caratteristiche di super-idrofilia, che ne esaltano la capacità di auto detergersi.

Tanto è maggiore l'irraggiamento con luce UV della superficie trattata, tanto diminuisce il suo angolo di contatto con l'acqua, che tende addirittura a zero dopo un ragionevole intervallo di tempo. L'acqua si spande e dilava con facilità. In pratica, all'azione del biossido di titanio che disgrega i depositi organici presenti sulla superficie trattata, grazie alla fotocatalisi, si aggiunge quella idrofila, che consente all'acqua piovana di detergere le piastrelle, asportando le macchie dalla loro superficie.

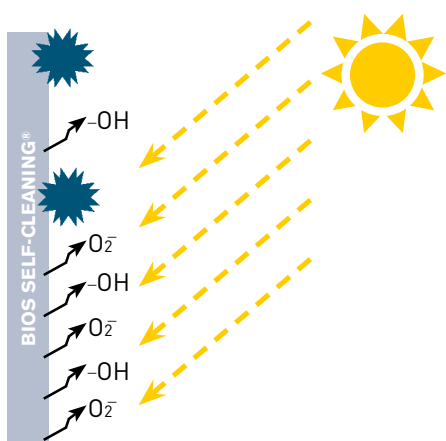

Quando la luce del sole (raggi UVA) irradia la superficie di **Bios Self-Cleaning®** si genera ossigeno attivo (O₂⁻, -OH)

When sunlight (UVA rays) hits the surface of the **Bios Self-Cleaning®**, active oxygen (O₂⁻, -OH) forms

La lumière du soleil (rayons UVA) qui rayonne sur la surface de **Bios Self-Cleaning®** génère de l'oxygène actif (O₂⁻, -OH)

Wenn das Sonnenlicht (UVA-Strahlen) die Oberflächen von **Bios Self-Cleaning®** bestrahlt, wird Aktivsauerstoff erzeugt (O₂⁻, -OH)

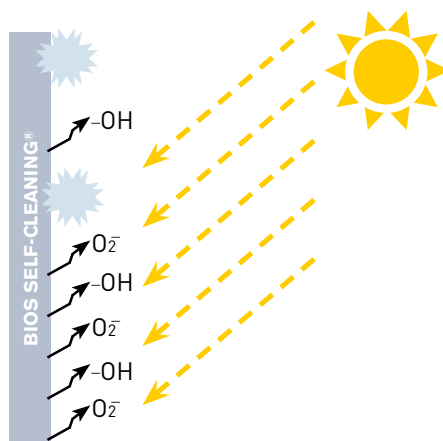

L'ossigeno attivo (O₂⁻, -OH) decompone lo sporco in sostanze meno aderenti

Active oxygen (O₂⁻, -OH) decomposes dirt into less adhesive substances

L'oxygène actif (O₂⁻, -OH) décompose les salissures en substances moins adhérentes

Der Aktivsauerstoff (O₂⁻, -OH) zersetzt den Schmutz in weniger haftfähige Stoffe



L'acqua piovana si espande sulla superficie di **Bios Self-Cleaning®** generando un sottilissimo strato che deterge ed elimina lo sporco precedentemente decomposto dall'ossigeno attivo

Rainwater spreads onto the **Bios Self-Cleaning®** surface, forming an extremely thin layer that cleanses and removes the dirt that has been decomposed by the active oxygen

L'eau de pluie glisse sur la surface de **Bios Self-Cleaning®** en constituant une fine couche d'eau qui nettoie et élimine les salissures précédemment décomposées par l'oxygène actif

Das Regenwasser breitet sich auf der Oberfläche von **Bios Self-Cleaning®** aus und erzeugt einen hauchdünnen Film, der den zuvor vom Aktivsauerstoff zersetzten Schmutz reinigt und beseitigt

bios self-cleaning®

HYDROTECT® TECHNOLOGY

The **HYDROTECT®** technology has been licensed out to over 100 manufacturers all over the world in the most diverse areas of application, from car-making to building. The owner of the patent is the Japanese holding TOTO, a global leader in photo-catalytic technology, with which **Casalgrande Padana** has entered into a Master Agreement. With the **HYDROTECT®** technology, the **Bios Self-Cleaning®** ceramics in facings and ventilated walls provide important responses through their self-cleaning and NOx-reduction properties (NOx are nitrogen oxides and compounds, largely responsible for urban air pollution).

In particular, **Bios Self-Cleaning®** can combine the well-known aesthetic features and performance of unglazed stoneware ceramic facings with a dramatic reduction in the need to clean or maintain the surfaces, which translates into remarkable savings and a long-lasting quality and appearance of the architectural features.

BIOACTIVE PROPERTIES FOR EXTERIOR FACINGS

The exclusive formulation of **Bios Self-Cleaning®** contains titanium dioxide (TiO₂), a natural substance traditionally used as a white pigment and to make food additives, toothpaste, makeup and so on. Because of its titanium dioxide content, **Bios Self-Cleaning®** can perform to the highest standards, especially as a facing, to which it adds:

- photo-catalytic properties, which, when triggered by light, can break up the organic substances and pollutants on the tile surface for a self-cleaning, air cleansing effect.
- super-hydrophilic properties, which make the most of its self-cleaning properties.

The higher the UV light on the treated surface, the smaller its angle of contact with water, which after a reasonable time is next to zero.

This means that the water will easily spread and wash off. Basically, the effect of the titanium dioxide that breaks up the organic matter on the treated surface is supported, through photo-catalysis, by the hydrophilic effect, whereby rainwater washes off any stain from the tile surface.

LA TECHNOLOGIE HYDROTECT®

Plus de 100 fabricants dans le monde entier utilisent, sous licence, la technologie **HYDROTECT®**, ceci dans les secteurs les plus variés, de l'industrie automobile au bâtiment. Le groupe japonais TOTO est titulaire du brevet et leader mondial dans le secteur des technologies photo-catalytiques. **Casalgrande Padana** a signé un Master Agreement avec le groupe Toto. Grâce à la technologie **HYDROTECT®**, les céramiques **Bios Self-Cleaning®**, utilisées pour les revêtements de façades traditionnelles et/ou ventilées, offrent des réponses significatives en termes de capacité autonettoyante et d'abattement des NOx (oxydes et mélanges d'azote, parmi les principaux polluants de l'air en milieu urbain).

En particulier, **Bios Self-Cleaning®** est en mesure d'allier les caractéristiques esthétiques et les performances des revêtements céramiques en grès cérame, à une importante diminution des opérations d'entretien et de nettoyage des surfaces, en garantissant pendant de longues années des économies en termes de coûts et du maintien de la qualité et de l'aspect du bâtiment.

LES CARACTÉRISTIQUES BIOACTIVES POUR LES REVÊTEMENTS D'EXTÉRIEUR

La formule exclusive de **Bios Self-Cleaning®** est à base de dioxyde de titane (TiO₂), une substance naturelle, couramment utilisée en tant que pigment blanc mais aussi pour fabriquer des additifs alimentaires, dentifrices, produits cosmétiques, etc.



Grâce au dioxyde de titane, **Bios Self-Cleaning®** est en mesure de garantir d'excellentes prestations, notamment comme revêtement de façade, en conférant à celle-ci :

- Des caractéristiques photocatalytiques, qui en présence d'un rayonnement lumineux, permettent de décomposer les substances organiques et les polluants qui se déposent sur la surface des carreaux, en garantissant des propriétés autonettoyantes et de purification de l'air.
- Des caractéristiques super-hydrophiles qui en exaltent les propriétés autonettoyantes.

Plus le rayonnement UV sur la surface traitée est intense, plus l'angle de contact entre l'eau et la surface diminue, et peut même arriver à zéro après un certain laps de temps. Ainsi, en glissant sur la surface, l'eau la nettoie plus facilement. En pratique, l'action photocatalytique du dioxyde de titane dégrade les dépôts organiques présents sur la surface traitée, et conjuguée aux propriétés hydrophiles, l'eau de pluie nettoie les carreaux en éliminant ainsi les salissures.

DIE HYDROTECT®-TECHNOLOGIE

Die Technologie **HYDROTECT®** wird unter Lizenz von mehr als 100 Produzenten in aller Welt verwendet und zwar in unterschiedlichsten Anwendungsbereichen, von der Automobilindustrie bis zum Bauwesen. Der Patentinhaber ist der japanische Konzern TOTO, das weltweit führende Unternehmen im Bereich der fotokatalytischen Technologien, mit dem **Casalgrande Padana** ein Master Agreement abgeschlossen hat. Dank der **HYDROTECT®** Technologie bieten die für die Gestaltung von Fassaden und hinterlüfteten Fassaden verwendeten Keramikprodukte **Bios Self-Cleaning®** bedeutende Lösungen in puncto selbstreinigende Fähigkeit und NOx-Abbau (Oxide und Stickstoffmischungen, die zu den Hauptschadstoffen der Stadtluft gehören). Insbesondere ist **Bios Self-Cleaning®** in der Lage, die

schon bekannten ästhetischen Eigenschaften und Leistungen der keramischen Feinsteinzeugbeläge mit einer drastischen Reduzierung der Reinigungs- und Instandhaltungseingriffe an den Oberflächen zu bereichern und garantiert dabei über viele Jahre hinweg eine merkbare Kosteneinsparung und das Aufrechterhalten der Vorzüge und des Erscheinungsbildes der architektonischen Struktur.

BIOAKTIVE EIGENSCHAFTEN FÜR EXTERNE VERKLEIDUNGEN

Die exklusive Formel von **Bios Self-Cleaning®** baut auf Titandioxyd (TiO₂) auf, ein natürlicher Stoff, der traditionell als weißes Pigment verwendet wird und für die Zubereitung von Lebensmittelzusatzstoffen, Zahnpasta, Kosmetika, usw.

Dank Titandioxyd garantiert **Bios Self-Cleaning®** ausgezeichnete Leistungen und verleiht besonders als Fassadenverkleidung folgende Eigenschaften:

- Fotokatalytische Eigenschaften, die bei Lichteinfall die Zersetzung der organischen Stoffe und der auf der Fliesenoberfläche abgesetzten Schadstoffe ermöglichen und Eigenschaften der Selbstreinigung und Luftreinigung garantieren.
- Super hydrophile Eigenschaften, welche die selbstreinigende Fähigkeit zusätzlich betont. Je größer die UV-Bestrahlung der behandelten Oberfläche, umso kleiner wird ihr Kontaktwinkel mit dem Wasser, der nach einem vernünftigen Zeitintervall sogar zum Nullwert neigt. Das bedeutet, dass sich das Wasser leicht ausbreitet und spült.

Praktisch wird die Wirkung von Titandioxyd, das die organischen Ablagerungen an der behandelten Oberfläche zersetzt, dank der Fotokatalyse mit einer hydrophilen Wirkung bereichert, mit der das Regenwasser die Fliesen reinigen und die Flecken von den Oberflächen entfernen kann.



bios self-cleaning®

EFFICACIA DEL PROCESSO AUTOPULENTE

Le prestazioni autopulenti di Bios Self-Cleaning® sono **estremamente efficaci e certificate**, ma è importante sottolineare che:

- **NON** sono in grado di rimuovere completamente i depositi che eccedono la proprietà autopulente, quali macchie che aderiscono alle facciate rapidamente, massicciamente e tenacemente, come i sigillanti al silicone
- **NON** sono in grado di rimuovere ruggine ed efflorescenze
- **NON** si attiva il processo autopulente in assenza di pioggia ed esposizione ai raggi UV.

EFFECTIVENESS OF THE SELF-CLEANING PROCESS

The self-cleaning property of Bios Self-Cleaning® is extremely effective and certified, but you should keep in mind that:

- **THEY CANNOT** remove all the stains that surpass their self-cleaning properties, such as stains that stick to the facing quickly, massively and stubbornly, e.g. silicone sealants.
- **THEY CANNOT** remove rust or crystals.
- **NO** self-cleaning process may take place without rain or exposure to UV rays.

Macchia organica 1 Organic stain 1 Tache organique 1 Organischer Fleck 1	Macchia organica 2 Organic stain 2 Tache organique 2 Organischer Fleck 2	Macchia non organica 1 Non organic stain 1 Tache non organique 1 Nicht organischer Fleck 1	Macchia non organica 2 Non organic stain 2 Tache non organique 2 Nicht organischer Fleck 2
Macchia oleosa, polvere e fuliggine, gas di scarico	Sigillante al silicone, graffiti, vernice, alveari, ragnatele	Sabbia, fango	Ruggine, efflorescenze, iridescenze
Greasy stain, dust and soot, exhaust gases	Silicone sealant, graffiti, paint, beehives, spider webs	Sand, mud	Rust, efflorescences, iridescent spots
Tache graisseuse, poussière et suie, gaz d'échappement	Colle silicone, graffitis, peinture, ruches, toiles d'araignée	Sable, boue	Rouille, efflorescences, irisations
Ölfleck, Staub und Russt, Abgas	Silikondichtmasse, Graffiti, Lack, Bienenstöcke, Spinnennetze	Sand, Schlamm	Rust, Ausblühungen, Irideszenzen



EFFICACIA AUTOPULENTE DI BIOS SELF-CLEANING® SELF-CLEANING PROPERTY OF BIOS SELF-CLEANING® EFFICACITÉ AUTONETTOYANTE DE BIOS SELF-CLEANING® WIRKSAMKEIT DER SELBSTREINIGUNG VON BIOS SELF-CLEANING®

Efficace	Difficile da rimuovere completamente mediante l'effetto autopulente	Efficace	Non efficace
Effective	Cannot be completely removed by self-cleaning	Effective	Ineffective
Efficace	Difficile à éliminer complètement au moyen de l'action autonettoyante	Efficace	Non efficace
Wirksam	Schwierig komplett zu entfernen durch die selbstreinigende Wirkung	Wirksam	Unwirksam

EFFICACITÉ DU PROCESSUS AUTONETTOYANT

Quoique la capacité autonettoyante de Bios Self-Cleaning® soit extrêmement efficace, outre à être certifiée, il convient de souligner que :

- son action **NE PEUT** éliminer totalement les dépôts allant au-delà de sa capacité autonettoyante, telles les taches qui adhèrent aux façades de manière rapide, massive et tenace, comme par exemple les colles silicone
- son action **NE PEUT** éliminer la rouille et les efflorescences
- le processus autonettoyant **NE PEUT S'ACTIVER** en absence de pluie et d'exposition aux rayons UV.

WIRKSAMKEIT DES SELBSTREINIGUNGSPROZESSES

Die selbstreinigenden Leistungen von Bios Self-Cleaning® sind extrem wirksam und zertifiziert, doch Folgendes ist unbedingt zu unterstreichen:

- **NICHT** komplett entfernt werden Ablagerungen, welche die Selbstreinigungsfähigkeiten überschreiten, so z.B. Flecken, die rasch massiv und hartnäckig an Fassaden anhaften wie Silikondichtmassen.
- **NICHT** entfernt werden Rost und Ausblühungen
- **NICHT** aktiviert wird der Selbstreinigungsprozess ohne Regen und UV-Bestrahlung.

Macchia organica 2

Organic stain 2

Tache organique 2

Organischer Fleck 2

Perché sigillanti al silicone e graffiti sono difficili da rimuovere con l'effetto autopulente?

Why are silicone sealants and graffiti hard to remove by the self-cleaning reaction?

Pourquoi l'effet autonettoyant élimine-t-il difficilement les colles silicone et les graffitis?

Weshalb sind Silikondichtmassen und Graffiti mit der selbstreinigenden Wirkung schwer zu entfernen?

La loro potente forza adesiva supera la proprietà autopulente di Bios Self-Cleaning®.

Inoltre, deviano i raggi UV dalla superficie delle piastrelle, pertanto è difficile che su tale superficie si generi l'ossigeno attivo.

Their powerful adhesive strength exceeds the self-cleaning power of Bios Self-Cleaning®.

In addition, they divert the UV rays from the tile surface, so active oxygen can hardly form on such surfaces.

Leur force d'adhésion très élevée est supérieure à la capacité autonettoyante de Bios Self-Cleaning®.

Par ailleurs, vu qu'ils dévient les rayons UV de la surface des carreaux, il est donc difficile que de l'oxygène actif puisse se former sur ce type de surface.

Ihr kräftiges Haftvermögen übertrifft die selbstreinigende Fähigkeit von Bios Self-Cleaning®.

Außerdem weisen sie die UV-Strahlen von der Fliesenoberfläche ab, sodass sich kaum Aktivsauerstoff auf ihnen bildet.

Macchia non organica 2

Non organic stain 2

Tache non organique 2

Nicht organischer Fleck 2

Perché ruggine ed efflorescenze NON vengono lavate via dall'effetto autopulente?

Why are rust and efflorescences NOT washed off by the self-cleaning reaction?

Pourquoi l'effet autonettoyant N'ÉLIMINE-T-IL ni la rouille ni les efflorescences ?

Weshalb werden Ausblühungen von der selbstreinigenden Wirkung NICHT weggespült?

Se ruggine ed efflorescenze aderiscono alla superficie delle piastrelle grazie all'ausilio di sostanze intermedie quali macchie e depositi oleosi, Bios Self-Cleaning® è in grado di rimuoverle. Se invece aderiscono direttamente, le proprietà di decomposizione di Bios Self-Cleaning® NON sono efficaci su queste sostanze inorganiche.

If the rust and efflorescences are glued to the tile surface by such mediums as greasy stains or spots, then Bios Self-Cleaning® can remove them.

If they are directly stuck to the surface, then the decomposing properties of Bios Self-Cleaning® ARE NOT effective on such inorganic substances.

Si la rouille et les efflorescences adhèrent à la surface des carreaux au moyen de substances intermédiaires, comme par exemple par le biais de taches et de dépôts graisseux, Bios Self-Cleaning® est en mesure de les éliminer. En revanche, si ces substances adhèrent directement aux carreaux, les propriétés de décomposition de Bios Self-Cleaning® NE SONT PAS efficaces sur ces substances non organiques.

Wenn Rost und Ausblühungen mit Zwischenstoffen wie Flecken bzw. Ölablagerungen an der Fliesenoberfläche anhaften, kann Bios Self-Cleaning® sie entfernen. Haften sie dagegen direkt an, dann sind die Zersetzungsfähigkeiten von Bios Self-Cleaning® auf solchen anorganischen Stoffen unwirksam.

bios self-cleaning®

L'ABBATTIMENTO DEGLI AGENTI INQUINANTI E LA PURIFICAZIONE DELL'ARIA

Una delle principali cause di inquinamento dell'atmosfera, che minaccia concretamente la salute dell'uomo e dell'ambiente, è costituita dai NOx (ossidi di azoto sottoprodotti dei processi di combustione), generati dagli automezzi, dal riscaldamento domestico e da alcuni processi industriali.

L'ossigeno attivo ($-OH$, O_2^-) prodotto dagli involucri di facciata rivestiti con **Bios Self-Cleaning®** ossida i NOx in sostanze non nocive (NO_3^- nitrato solubile in acqua), che vengono rimosse attraverso il dilavamento dell'acqua piovana. Grazie alla loro scarsa quantità, i NO_3^- ossidati dalla reazione fotocatalitica non hanno alcuna influenza sull'acidificazione del suolo.

Le prestazioni di abbattimento dei NOx garantite da **Bios Self-Cleaning®** offrono un apprezzabile contributo al miglioramento della qualità ambientale degli insediamenti urbani. Basti pensare che un rivestimento di 1000 metri quadrati di facciata con **Bios Self-Cleaning®** ha la capacità di purificare l'aria in misura paragonabile a un bosco delle dimensioni di un campo da calcio, oppure di eliminare gli ossidi di azoto (NOx) emessi da 70 automobili nel corso di un'intera giornata.

POLLUTANT-REDUCTION AND AIR-CLEANSING PROPERTIES

One of the main sources of atmospheric pollution, which really threatens human and environmental health, are NOx (nitrogen oxides as combustion by-products) from vehicles, heating and some industrial processes.

The active oxygen ($-OH$, O_2^-) produced by the **Bios Self-Cleaning®** facings oxidises the NOx into non-harmful substances (NO_3^- water-soluble nitrate), which are washed off by rainwater. The NO_3^- oxidised by the photo-catalytic reaction is too little to have any influence on soil acidification.

The guaranteed NOx-reducing properties of **Bios Self-Cleaning®** make an appreciable contribution to the improvement of the environmental standards of urban settlements. Just think that a 1000 sqmt **Bios Self-Cleaning®** facing can purify the air like a wood the size of a football pitch or remove the nitrogen oxides (NOx) emitted by 70 cars during one day.

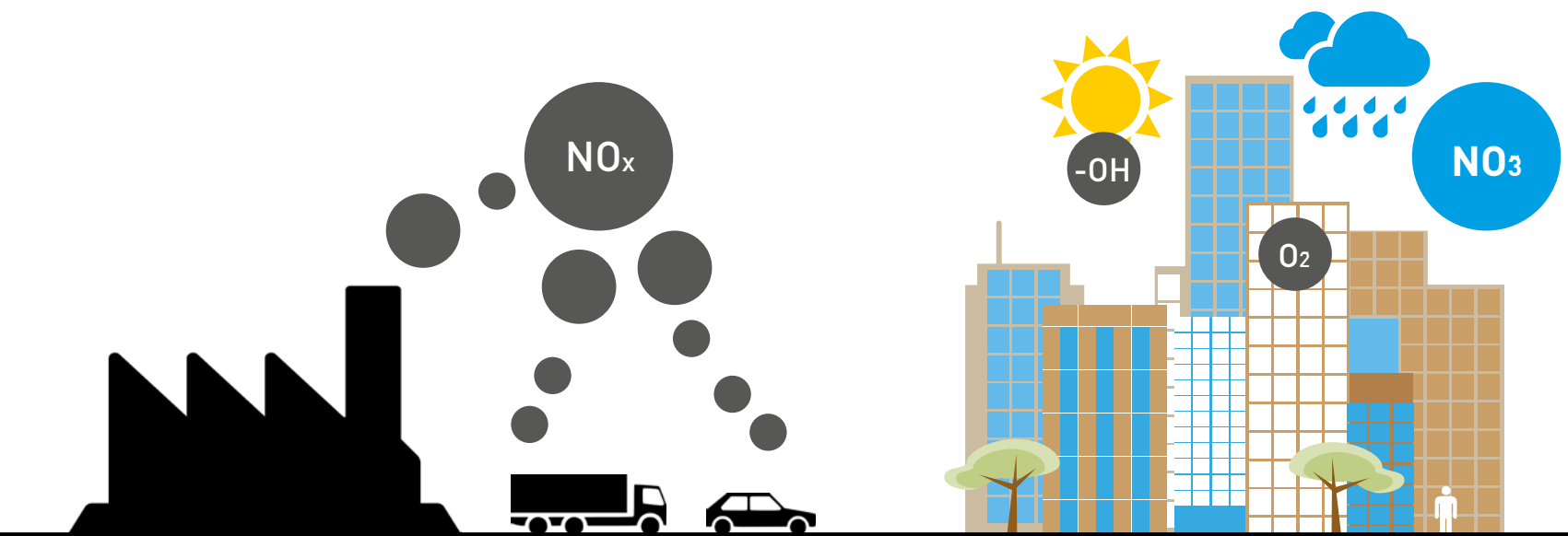

ABATTEMENT DES AGENTS POLLUANTS ET PURIFICATION DE L'AIR

Une des principales causes de la pollution de l'air, qui par ailleurs menace concrètement la santé de l'homme et l'environnement, est représentée par les NOx (oxydes d'azote, sous-produits du processus de combustion) émis par les véhicules, le chauffage domestique et certains processus industriels. L'oxygène actif ($-OH$, O_2^-) généré par les façades revêtues des produits **Bios Self-Cleaning®**, oxyde les NOx en substances non nocives (NO_3^- nitrate hydrosoluble) qui sont ensuite éliminés par l'eau de pluie. Grâce à leur faible quantité, les NO_3^- oxydés par la réaction photocatalytique n'ont aucune incidence sur l'acidification du sol.

La capacité d'abattement des NOx effectuée par **Bios Self-Cleaning®** offre une contribution appréciable à l'amélioration de la qualité de l'environnement des centres urbains.

Il suffit de penser qu'une façade de 1000 m² revêtue de **Bios Self-Cleaning®** a une capacité de purifier l'air comparable à celle d'une forêt de la taille d'un terrain de football, ou d'éliminer les oxydes d'azote (NOx) émis pendant 24 heures par 70 véhicules.

DER ABBAU DER SCHADSTOFFE UND DIE REINIGUNG DER LUFT

Eine der Hauptursachen der Luftverschmutzung, die unsere Gesundheit und unsere Umgebung konkret bedrohen, sind die NOx (Stickstoffoxyde als Nebenprodukte des Verbrennungsprozesses), die von Fahrzeugen, Raumheizungen und einigen Industrieverfahren erzeugt werden. Der von mit **Bios Self-Cleaning®** verkleideten Fassaden erzeugte Aktivsauerstoff ($-OH$, O_2^-) oxydiert die NOx in unschädliche Stoffe (NO_3^- wasserlösliches Nitrat), die durch Auswaschung mit Regenwasser entfernt werden. Dank ihrer geringen Menge haben durch fotokatalytische Reaktion oxydierten NO_3^- keinerlei Einfluss auf die Bodensäuerung. Die von **Bios Self-Cleaning®** garantierten NOx-Abbauleistungen bieten einen schätzenswerten Beitrag zur Verbesserung der Qualität der Umwelt in Wohngebieten. Man denke allein schon daran, dass eine 1000 Quadratmeter große mit **Bios Self-Cleaning®** verkleidete Fassade die Fähigkeit besitzt, die Luft in einem Ausmaß zu reinigen, das mit einem Wald in der Größe eines Fußballplatzes vergleichbar ist, oder die Stickstoffoxyde (NOx) zu beseitigen, die von 70 Autos im Laufe eines ganzen Tages freigesetzt werden.

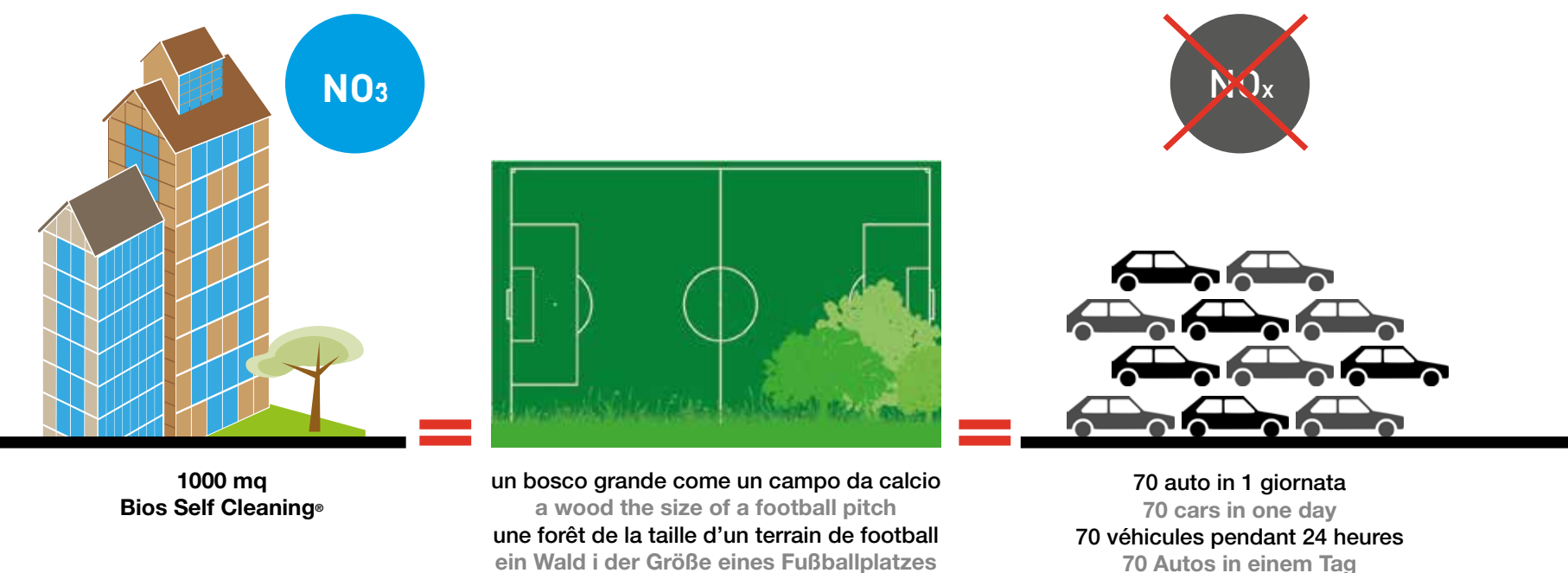

bios self-cleaning®

DURATA DELLE PRESTAZIONI

Grazie a una severa serie di prove di laboratorio è stato possibile dimostrare che le prestazioni di **Bios Self-Cleaning®** non si riducono nel tempo. La durabilità è stata confermata sottoponendo le lastre ceramiche a un test d'invecchiamento accelerato in condizioni equiparabili a 50 anni di esposizione all'esterno. Per quanto concerne la resistenza al calpestio, va evidenziato come la tecnologia HYDROTECT®, inglobata a caldo sulla superficie di **Bios Self-Cleaning®** durante il ciclo di produzione industrializzata, sia in grado di assicurare nel tempo le sue caratteristiche rispettando le prescrizioni relative alle sollecitazioni da traffico leggero e le relative avvertenze di manutenzione.

CERTIFICAZIONI

Le prestazioni della tecnologia HYDROTECT®, con cui sono trattate le lastre ceramiche in grès porcellanato **Bios Self-Cleaning®**, sono certificate secondo le più importanti norme internazionali.

LONG-TERM EFFICIENCY

A number of strict lab tests proved that the efficiency of **Bios Self-Cleaning®** does not diminish over time. The durability of the ceramic slabs has been confirmed by an accelerated aging test, the conditions of which were comparable to 50 years' outdoor exposure. Note that in heavy-traffic areas, the HYDROTECT® technology, if hot embedded in the **Bios Self-Cleaning®** surface during the industrial production process, will perform well over time and will fulfil the applicable light traffic resistance and maintenance requirements.

CASALGRANDE PADANA'S PRODUCT RANGES

The performance of the HYDROTECT® technology, applied to **Bios Self-Cleaning®** unglazed stoneware ceramic slabs, is certified according to the most important international standards.

DURÉE DES TRAITEMENTS

Les nombreux essais rigoureux menés en laboratoire ont permis de démontrer la très longue durée de vie des propriétés de **Bios Self-Cleaning®**. Cette durabilité a été confirmée en faisant subir des tests de vieillissement accéléré aux dalles céramiques, ceci à des conditions comparables à 50 ans d'exposition aux agents atmosphériques. En ce qui concerne la résistance au bruit d'impact, il faut souligner que la technologie HYDROTECT®, englobée à chaud sur la surface de **Bios Self-Cleaning®** pendant le cycle de fabrication, est en mesure de garantir longuement ses caractéristiques, en respectant les prescriptions sur les sollicitations dérivant d'un trafic léger et les règles d'entretien correspondantes.

CERTIFICATIONS

Les propriétés de la technologie HYDROTECT®, qui caractérisent les dalles céramiques en grès cérame **Bios Self-Cleaning®**, sont certifiées selon les plus importantes normes internationales.

DAUERHAFTIGKEIT DER LEISTUNGEN

Dank einer Reihe strenger Labortests konnte nachgewiesen werden, dass die Leistungen von **Bios Self-Cleaning®** im Laufe der Zeit nicht nachlassen. Die Dauerhaftigkeit wurde bestätigt, indem die Keramikplatten einem beschleunigten Alterungstest unter Verhältnissen ausgesetzt wurden, die mit einer 50jährigen Exposition im Freien vergleichbar sind. Was die Begehungsfestigkeit betrifft, ist zu sagen, dass die während des industriellen Produktionsprozesses warm in die Oberfläche von **Bios Self-Cleaning®** eingearbeitete HYDROTECT® Technologie in der Lage ist, ihre Leistungen dauerhaft zu sichern und die Vorschriften für leichte Verkehrsbeanspruchungen und die entsprechenden Instandhaltungshinweise einzuhalten.

ZERTIFIZIERUNGEN

Die Leistungen der HYDROTECT® Technologie, mit der die Keramikplatten aus **Bios Self-Cleaning®** Feinsteinzeug behandelt werden, sind nach den wichtigsten internationalen Normen zertifiziert.



bios unicolore iperbianco cm 60x120 - 23⁵/₈"x47⁷/₈"

bios HYDROTECT™ antibacterial®

Bios Antibacterial® è la linea di prodotti da rivestimento e pavimentazione in gres porcellanato capaci di abbattere al 99,9% i quattro principali ceppi batterici presenti negli ambienti confinati: *Staphylococcus aureus*, *Escherichia coli*, *Pseudomonas aeruginosa*, *Enterococcus faecalis*.

La tecnologia **HYDROTECT®** sfrutta le caratteristiche antibatteriche del biossido di titanio, un materiale naturale che non rilascia alcuna emissione nociva e anche negli ambienti interni consente di ridurre notevolmente le sostanze dannose per la salute dell'uomo, rendendo gli ambienti più salubri ed eliminando allo stesso tempo i cattivi odori.

Bios Antibacterial® is the range of porcelain stoneware flooring and wall covering products that can remove up to 99.9% of the four most common bacterial strains in confined environments, i.e.: *Staphylococcus aureus*, *Escherichia coli*, *Pseudomonas aeruginosa*, and *Enterococcus faecalis*.

The **HYDROTECT®** technology exploits the antibacterial properties of titanium dioxide, a natural material that doesn't release any harmful emission and that, in interior applications, allows for a considerable reduction of harmful substances, thereby ensuring a healthier environment while eliminating odours.

Bios Antibacterial® est une ligne de produits de revêtement et de sols en grès cérame, en mesure d'éliminer 99,9 % des quatre principales souches bactériennes présentes dans les espaces confinés. *Staphylococcus aureus*, *Escherichia coli*, *Pseudomonas aeruginosa*, *Enterococcus faecalis*.

La technologie **HYDROTECT®** utilise les caractéristiques antibactériennes du dioxyde de titane, matériau naturel qui ne produit aucune émission nocive et qui, à l'intérieur, permet de réduire considérablement la quantité de substances nocives pour la santé de l'homme, en assainissant les environnements et en éliminant aussi les mauvaises odeurs.

Bios Antibacterial® ist eine Produktlinie an Verkleidungen und Bodenbelägen aus Feinsteinzeug, die in der Lage ist, bis zu 99,9 % der vier hauptsächlich, in geschlossenen Räumen auftretenden Bakterienstämme abzutöten: *Staphylococcus aureus*, *Escherichia coli*, *Pseudomonas aeruginosa*, *Enterococcus faecalis*.

Die **HYDROTECT®**-Technologie nutzt die antibakteriellen Eigenschaften von Titandioxid, einem natürlichen Material, das keine schädlichen Emissionen freisetzt und die Möglichkeit verleiht, auch in Innenräumen für den Menschen schädliche Substanzen erheblich zu reduzieren. Damit trägt es zu einer gesünderen und gleichzeitig von unangenehmen Gerüchen befreiten Umgebung bei.



CAUSE ED EFFETTI DEI BATTERI NEGLI AMBIENTI

Lo *Staphylococcus aureus*, l'*Escherichiacoli*, lo *Pseudomonas aeruginosa* e l'*Enterococcus faecalis*, sono i principali responsabili delle infezioni che si registrano in ambito ospedaliero e sono stati adottati come indicatori standard perché rappresentano la categoria più aggressiva, in alcuni casi super resistente anche agli antibiotici.

Quando un prodotto può definirsi antibatterico

Dopo severe prove di laboratorio, **Bios Antibacterial® HYDROTECT** è risultato altamente efficace, in quanto capace di abbattere del 99,9% i quattro principali ceppi batterici presenti negli ambienti confinati: *Staphylococcus aureus*, *Enterococcus faecalis*, *Escherichia coli*, *Pseudomonas aeruginosa*.

Nella pratica il 100% di antibattericità non può essere assicurato, la soglia di efficacia è stata quindi fissata dai ricercatori di tutto il mondo a oltre il 90%, perché solo a questi livelli si può registrare una riduzione realmente significativa dei batteri. Per questo motivo, in termini di efficacia antibatterica, la comunità scientifica non prende in considerazione valori inferiori alla soglia del 90% e i prodotti che non raggiungono questo livello non possono essere definiti antibatterici. La ricerca ha inoltre evidenziato che **Bios Antibacterial® HYDROTECT** in presenza di umidità, tradizionale terreno fertile per lo sviluppo della flora batterica, vede addirittura amplificare i propri effetti benefici. Va comunque evidenziato come la tecnologia **Bios Antibacterial® HYDROTECT**, pur essendo capace di abbattere al 99,9% i 4 principali ceppi batterici presenti negli ambienti e ridurre la crescita virale, non possa garantire in assoluto l'immunità da infezioni. Si consiglia pertanto, in funzione delle specifiche destinazioni d'uso degli ambienti, di sottoporre le superfici ad appropriati cicli di pulizia e disinfezione.

LE PROPRIETÀ ANTIODORE

I cattivi odori sono tra le cause più invalidanti della qualità degli ambienti, oltre che segnale tangibile di bassi livelli di igiene dell'aria e delle superfici. Nei locali bagno i cattivi odori vengono generati dalla combinazione tra urea, germi e batteri, che producono ammoniaca e trimetilammina. Effetti analoghi possono attivarsi nelle cucine, causati dalla reazione con microresidui organici. Inoltre, sempre nei bagni e a bordo piscina la concentrazione di sebo e residui cutanei, in combinazione con i germi, dà luogo alla formazione di macchie e depositi viscosi che, oltre al degrado nell'aspetto dei rivestimenti, possono ridurre le caratteristiche antiderapanti delle superfici e la sicurezza al calpestio. In tutti questi casi, l'effetto antibatterico di **Bios Antibacterial® HYDROTECT**, aiuta a eliminare i cattivi odori e a mantenere valide le caratteristiche antiderapanti delle piastrelle anche in assenza totale di luce, offrendo garanzie nel più ampio spettro.

CAUSES AND EFFECTS OF BACTERIA IN THE ENVIRONMENT

Staphylococcus aureus, *Escherichia coli*, *Pseudomonas aeruginosa* and *Enterococcus faecalis* are largely responsible for hospital-acquired infections and have been taken as standard indicators, because they are the most aggressive class of bacteria, which sometimes can even be resistant to antibiotics.

When a product can be called antibacterial

After strict lab tests, **Bios Antibacterial® HYDROTECT** turned out to be extremely effective, as it can remove 99.9% of the main four bacterial strains living in confined areas: *Staphylococcus aureus*, *Enterococcus faecalis*, *Escherichia coli*, *Pseudomonas aeruginosa*.

As a matter of fact, a 100% anti-bacterial effect cannot be ensured, so the effectiveness threshold has been set by researchers all over the world at over 90%, because only at such levels can a really significant reduction in bacteria be measured. That's why in terms of antibacterial effectiveness the scientific community will not take into account any rating under 90% and products that fail to achieve such level may not be called antibacterial. In addition, research has shown that **Bios Antibacterial® HYDROTECT** needs no light to be activated, and in a humid environment, which is traditionally a fertile ground for the growth of bacterial flora, its beneficial effects are even greater. Note, however, that, even if capable of removing 99.9% of the 4 main bacterial strains living in the environment and reducing viral growth, the **Bios Antibacterial® HYDROTECT** technology cannot ensure perfect immunity to infections. Therefore, depending on the way a place is to be used, the surfaces should be treated with appropriate cleaning and disinfection procedures.

DEODORISING PROPERTIES

Bad smells are some of the factors that most deteriorate the quality of an environment, as well as being a tangible sign of a low level of air and surface hygiene. In bathrooms, bad smells are generated by a combination of urea, germs and bacteria that produce ammonia and trimethylamine. Similar effects may be had in kitchens as a reaction with organic micro-residues. In addition, also in bathrooms or poolside, a concentration of sebum and shed skin cells, combined with germs, forms stains and slippery spots that, as well as deteriorating the appearance of a facing, may reduce the anti-slipping properties of the surfaces and their safety when walked over. In all these cases, the antibacterial effect of **Bios Antibacterial® HYDROTECT** helps remove bad smells and retain the anti-slipping properties of the tiles even without any light, for perfect safety.

bios HYDROTECT™ antibacterial®

CAUSES ET EFFETS DES BACTÉRIES DANS LE MILIEU AMBIANT

Le *Staphylococcus aureus*, l'*Escherichia coli*, le *Pseudomonas aeruginosa* et l'*Enterococcus faecalis* sont les principaux responsables des infections enregistrées en milieu hospitalier.

Ils ont été adoptés comme indicateurs standard car ce sont les souches les plus agressives, dans certains cas même résistantes aux antibiotiques.

Quand un produit peut être défini comme antibactérien ?

Après de rigoureux essais en laboratoire, **Bios Antibacterial® HYDROTECT** résulte extrêmement efficace, étant capable d'abattre 99,9% des quatre principales souches bactériennes présentes dans les espaces fermés : *Staphylococcus aureus*, *Enterococcus faecalis*, *Escherichia coli*, *Pseudomonas aeruginosa*.

Dans la pratique, étant difficile d'assurer des propriétés 100% antibactéricides, la communauté scientifique mondiale a fixé le seuil d'efficacité à plus de 90%, car c'est seulement à ce niveau que l'on peut enregistrer une réduction vraiment significative des bactéries.

Pour cette raison, il faut souligner qu'en termes d'efficacité antibactérienne, la communauté scientifique ne prend même pas en considération les valeurs inférieures à 90%, et donc les produits qui n'atteignent pas cette limite ne peuvent en aucun cas être définis comme antibactériens.

La recherche a également montré que **Bios Antibacterial® HYDROTECT** n'a pas besoin de lumière pour s'activer, et qu'en

présence d'humidité, facteur propice au développement de la flore bactérienne, ses effets bénéfiques augmentent ultérieurement. Il faut souligner que même si la technologie **Bios Antibacterial® HYDROTECT** est capable d'abattre 99,9% des 4 principales souches bactériennes et de réduire leur croissance, elle ne peut toutefois garantir une immunité totale contre les infections. Il est donc conseillé, en fonction de chaque contexte d'utilisation spécifique, de soumettre les surfaces à des cycles de nettoyage et de désinfection adéquats.

LES PROPRIÉTÉS ANTI-ODEURS

Les mauvaises odeurs sont une des causes qui nuisent le plus à la qualité de l'air et sont aussi le signe tangible du bas niveau d'hygiène de l'air et des surfaces.

Dans les salles de bains, les mauvaises odeurs sont générées par la combinaison entre l'urée, les germes et les bactéries, qui produisent de l'ammoniac et de la triméthylamine.

Des effets analogues peuvent se produire en cuisine, dus à la réaction avec des micro résidus organiques.

Par ailleurs, en salle de bains ou sur le bord des piscines, la concentration de sébum et de résidus cutanés, en combinaisons aux germes, donne lieu à la formation de taches et de dépôts visqueux, qui outre à dégrader l'aspect des revêtements, peuvent réduire les caractéristiques antiglisse des surfaces, et donc la sécurité des personnes. L'effet antibactérien de **Bios Antibacterial® HYDROTECT** aide toujours à éliminer les mauvaises odeurs et à préserver les caractéristiques antiglisse des carreaux, même en l'absence totale de lumière, en offrant des garanties à large spectre.

Emergency Salam
Surgery Centre di Khartoum



URSACHEN UND AUSWIRKUNGEN VON BAKTERIEN IN RÄUMEN

Die *Staphylococcus aureus*, *Escherichia coli*, *Pseudomonas aeruginosa* und *Enterococcus faecalis* sind die Hauptverantwortlichen der Infektionen, die sich in Krankenhausbereichen ereignen und wurden als Standard-Anzeiger übernommen, da sie die aggressivste Kategorie darstellen, die in einigen Fällen sogar gegen Antibiotika resistent ist.

Wann kann ein Produkt als antibakteriell bezeichnet werden

Nach strengen Labortests hat sich Bios Antibacterial® HYDROTECT als höchst wirksam erwiesen, da das Produkt die vier in angrenzenden Bereichen vorhandenen wichtigsten Bakterienstämme zu 99,9% abbaut: *Staphylococcus aureus*, *Enterococcus faecalis*, *Escherichia coli*, *Pseudomonas aeruginosa*.

In der Praxis kann eine zu 100% bakterientötende Wirkung nicht zugesichert werden, sodass die Wirksamkeitsschwelle von den Forschern aller Welt auf über 90% festgelegt wurde, denn nur in diesem Ausmaß kann eine wirklich bedeutende Reduzierung der Bakterien festgestellt werden. Aus diesem Grund berücksichtigt die wissenschaftliche Gemeinschaft in Hinsicht auf die antibakterielle Wirksamkeit keine Werte unter 90% und Produkte, die dieses Niveau nicht erreichen, können nicht als antibakteriell bezeichnet werden. Die Forschung hat außerdem festgestellt, Bios Antibacterial® HYDROTECT kein Licht benötigt, um aktiv zu werden und bei Feuchtigkeit, einem bekanntlich begünstigenden Zustand für die Entwicklung von Bakterienflora, die vorteilhaften Wirkungen sogar

noch verstärkt. Es ist auf jeden Fall zu sagen, dass die Technologie Bios Antibacterial® HYDROTECT trotz ihrer Fähigkeit, die 4 wichtigsten in der Umgebung vorhandenen Bakterienstämme zu 99,9% abzubauen und die Virenwucherung zu reduzieren, die Immunität gegenüber Infektionen nicht absolut garantieren kann. Deshalb wird empfohlen, auf den Oberflächen in Funktion der spezifischen Einsatzbedingungen der Räume angemessenen Reinigungs- und Desinfektionszyklen vorzunehmen.

DIE GERUCHHEMMENDEN EIGENSCHAFTEN

Schlechte Gerüche gehören zu den Ursachen, die der Qualität der Räume am meisten schaden und sind außerdem ein offensichtliches Zeichen geringer Hygieneniveaus in der Luft und auf den Flächen. Im Badezimmer werden schlechte Gerüche von der Kombination zwischen Urin, Keimen und Bakterien verursacht, die Ammoniak und Trimethylamin erzeugen. Gleiche Folgen können sich in Küchen durch die Reaktion mit organischen Mikrorückständen ergeben. Außerdem bilden sich in Badezimmern und an Schwimmbadrandern durch die Konzentration von Hauttalg und Hautrückständen in Kombination mit Keimen Flecken und schlüpfrige Ablagerungen, die nicht nur die Auskleidungen unschön machen, sondern auch die rutschhemmenden Eigenschaften der Oberflächen und die Trittsicherheit reduzieren. In allen diesen Fällen hilft die antibakterielle Wirkung von Bios Antibacterial® HYDROTECT, die schlechten Gerüche zu beseitigen und die rutschhemmenden Eigenschaften der Fliesen zu bewahren, auch ganz ohne Licht und bietet deshalb eine Garantie in einem ganz breiten Spektrum.



bios HYDROTECT™ antibacterial®

STAPHYLOCOCCUS AUREUS

Lo Staphylococcus aureus è un batterio Gram positivo di forma sferica. Il suo sviluppo ha luogo fra 10°C e 45°C con un optimum di temperatura compreso tra i 30°C e i 37°C; per quanto riguarda il pH, fra 4 e 9 con un optimum fra 7 e 7,5. Pur non essendo sporigeni gli stafilococchi mostrano una notevole resistenza a condizioni ambientali sfavorevoli. È diffuso in generale nell'acqua, sulla pelle e nelle mucose. Introdotto nel nostro organismo, può generare infezioni di varia natura. Le infezioni da Staphylococcus aureus acquisite in ambiente ospedaliero in genere sono causate da stipti resistenti a vari chemioterapici e si manifestano sovente in forma epidemica. L'insorgere di queste epidemie in particolari reparti può rappresentare un evento di particolare gravità che pone seri problemi profilattici e terapeutici.

Staphylococcus is a spherical-shaped Gram-positive bacterium. It develops at a temperature of 10°C to 45°C, with optimum temperature being 30°C to 37°C; pH must be 4 to 9, with optimum pH being 7 to 7.5. Even if not sporogenic, staphylococci are extremely resistant to unfavourable environmental conditions. Usually widespread in water, skin and mucous membranes. If it enters our organism, it can induce a wide range of infections. Hospital-acquired infections with Staphylococcus aureus are usually caused by chemotherapeutic-resistant cells and often come in the form of veritable epidemics. In some wards, the outbreak of such epidemics may be an extremely challenging event that may raise serious prophylactic and therapeutic problems.

Le Staphylococcus aureus est une bactérie de forme sphérique à Gram positif. Son développement a lieu entre 10 °C et 45 °C avec une température optimale comprise entre 30 °C et 37 °C ; en ce qui concerne le pH, il se multiplie à un pH entre 4 et 9, le pH optimal étant compris entre 7 et 7,5. Bien qu'il ne s'agisse pas d'un microorganisme sporogène, le staphylocoque présente une résistance remarquable aux conditions ambiantes défavorables. On le trouve surtout dans l'eau, sur la peau et les muqueuses. Une fois dans notre organisme, il peut causer différents types d'infection. En milieu hospitalier, les infections à Staphylococcus aureus sont généralement causées par des souches résistantes à différentes substances chimiothérapeutiques et elles se manifestent souvent sous forme épidémique. L'apparition de ce type d'épidémie dans certains services hospitaliers peut constituer un événement extrêmement grave qui pose de sérieux problèmes prophylactiques et thérapeutiques.

Staphylococcus aureus ist ein gram-positives kugelförmiges Bakterium. Es entwickelt sich zwischen 10°C und 45°C, die optimalen Temperaturverhältnisse liegen zwischen 30°C und 37°C. Der pH-Wert liegt zwischen 4 und 9, optimal zwischen 7 und 7,5. Obwohl sie nicht sporogen sind, sind Staphylokokken unter ungünstigen Umgebungsverhältnissen besonders resistent. Das Bakterium ist generell im Wasser, auf der Haut und in den Schleimhäuten zu finden. Im menschlichen Organismus kann das Bakterium Infektionen verschiedener Art verursachen. In Krankenhausbereichen durch Staphylococcus aureus zu-

gezoogene Infektionen werden normalerweise von Stammzellen verursacht, die gegen verschiedene Chemotherapien resistent sind, und offenbaren sich häufig in epidemischer Form. Das Auftreten solcher Epidemien in bestimmten Abteilungen kann besonders schlimm sein und schwere prophylaktische und therapeutische Probleme hervorrufen.

ESCHERICHIA COLI

Escherichia coli è una specie che fa parte della famiglia delle Enterobacteriaceae, microrganismi Gram negativi ubiquitari che si trovano nel suolo, nell'acqua, nella vegetazione e fanno parte della flora intestinale della maggior parte degli animali compreso l'uomo. La sua coltura è molto facile con una grande tolleranza di variazione del pH, con un optimum di 7,5. La temperatura ottimale è 37°C. Resiste bene al calore: incubato a 45°C.

L'Escherichia coli è un ospite normale dell'organismo umano in cui rappresenta la specie predominante della comunità batterica facoltativa residente nell'intestino crasso; per questo motivo la sua presenza in un dato materiale (ad es. acqua) può essere considerata un indizio sicuro di una contaminazione fecale.

Escherichia coli is a species of the family Enterobacteriaceae, ubiquitous Gram-negative micro-organisms that can be found in soil, water, vegetation and live in the gut flora of most animals, including humans. Cultures of Escherichia coli are very easy to make, as they tolerate a wide range of pH, with optimum pH being 7.5. Optimum temperature is 37°C. They resist quite well to incubated heat at 45°C. Escherichia coli is a normal host of human organism, in which it is the prevalent species of the facultative bacterial community living in the large intestine; that's why finding it in a given material (e.g. water) may be regarded as certain evidence of faecal contamination.

L'Escherichia coli, bacille appartenant à la famille des Enterobacteriaceae, est un microorganisme ubiquitaire à Gram négatif. On le trouve dans l'eau, le sol et la végétation, et il fait partie de la flore intestinale de la plupart des animaux, y compris de l'être humain. Sa culture est très facile avec une grande tolérance de variation de pH, le pH optimal étant 7,5. Sa température optimale est de 37 °C. Incubé à 45 °C, ce bacille résiste à la chaleur. L'Escherichia coli est une bactérie commensale prédominante de la flore aérobie facultative du gros intestin ; pour cette raison, sa présence dans un milieu donné (l'eau, par exemple) est un indice sûr de contamination fécale.

Escherichia coli ist eine Spezies, die zur Familie der Enterobacteriaceae gehört, ubiquitäre gram-negative Mikroorganismen, die sich im Erdreich, im Wasser und in der Vegetation befinden und zur Darmflora der meisten Tiere und auch der Menschen gehören. Die Fortpflanzung erfolgt sehr leicht, mit großer pH-Variationstoleranz, optimal mit einem pH-Wert von 7,5. Die optimale Temperatur liegt bei 37°C.



Staphylococcus aureus

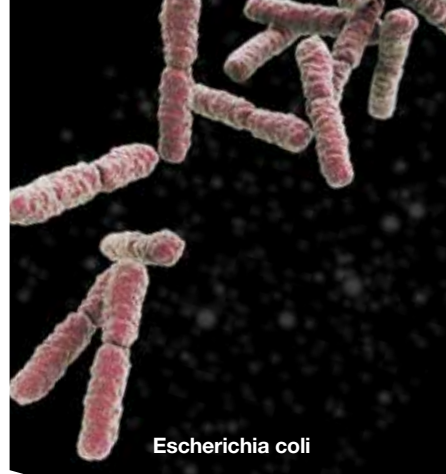

Escherichia coli



Pseudomonas aeruginosa

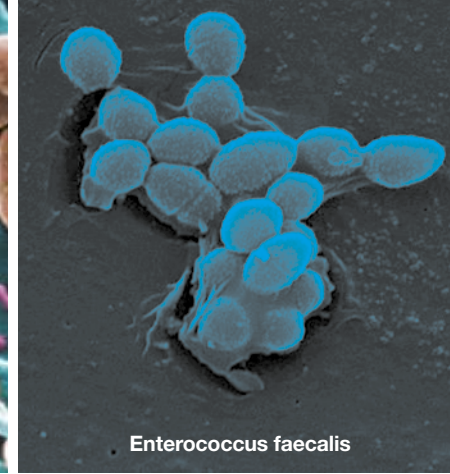

Enterococcus faecalis

Das Bakterium ist sehr wärmebeständig: Inkubation bei 45°C. Das Escherichia coli ist ein üblicher Gast des menschlichen Organismus, wo es die dominierende Species der im Dickdarm residenten fakultativen Bakteriengemeinschaft darstellt; deshalb ist seine Anwesenheit in einem bestimmten Material (z.B. Wasser) ein sicherer Hinweis auf eine fäkale Kontamination.

PSEUDOMONAS AERUGINOSA

Pseudomonas aeruginosa è un batterio Gram negativo, capace di crescere a temperature comprese fra un minimo di 4°C e di un massimo di 42°C, ma non di svilupparsi al di sotto di pH 4.5. È un microorganismo molto presente nelle acque, nel suolo e come commensale sulla cute e nell'intestino. La sua scarsa o nulla sensibilità ai più comuni antibiotici fa sì che il suo sviluppo venga favorito da un qualsiasi trattamento con medicinali antibatterici: l'azione dell'antibiotico, infatti, riducendo la concorrenza della restante popolazione microbica, permette al batterio di raggiungere consistenze numeriche altrimenti impossibili.

Pseudomonas aeruginosa is a Gram-negative bacterium, which can grow at a temperature of 4°C up to 42°C, but will not develop if pH is less than 4.5. It is a micro-organism that can be often found in water, soil and as a commensal on skin or guts. Because of its poor or no sensitivity to the most common antibiotics, its growth is boosted by any antibacterial drug: actually, by reducing the competition of the rest of the microbial population, the effect of the antibiotic enables the bacterium to grow in numbers that would otherwise be impossible.

Pseudomonas aeruginosa est une bactérie à Gram négatif, capable de se développer à une température comprise entre un minimum de 4 °C et un maximum de 42 °C, mais incapable de se développer à un pH inférieur à 4.5. Surtout présent dans l'eau et le sol, ce microorganisme est une bactérie commensale de la peau et de l'intestin. Sa sensibilité, faible ou quasi nulle, aux antibiotiques les plus courants, fait que son développement est favorisé par de nombreux traitements à base de traitements antibactériens : en effet, l'action de l'antibiotique, en réduisant la concurrence de la population microbienne restante, permet à la bactérie d'atteindre une consistance numérique qui serait sinon impossible.

Pseudomonas aeruginosa ist ein gram-negatives Bakterium, das bei Temperaturen zwischen mindestens 4°C und maximal 42°C wachsen kann, sich bei pH-Werten unter 4.5 jedoch nicht entwickelt. Dieser Mikroorganismus ist stark vertreten in Gewässern, im Erdboden und als Kommensale auf der Haut und im Darm. Durch seine geringe oder fehlende Empfindlichkeit gegenüber den herkömmlichen Antibiotika wird seine Entwicklung bei irgendwelchen Behandlungen mit antibakteriellen Medikamenten gefördert: Die Wirkung des Antibiotikums erlaubt es dem Bakterium durch die Reduzierung der Konkurrenz der restlichen mikrobiellen Population tatsächlich, eine sonst nicht mögliche numerische Konsistenz zu erreichen.

ENTEROCOCCUS FAECALIS

Gli enterococchi sono batteri Gram positivi molto diffusi in natura. Fanno parte della normale flora microbica intestinale dell'uomo e degli animali, ma si ritrovano anche nelle piante e negli insetti.

Sono utilizzati come indicatori di contaminazione fecale nell'acqua e negli alimenti. Crescono a 10-45°C, in soluzione contenente fino al 6,5% di cloruro di sodio, a pH 9,6 e sopravvivono ad una temperatura di 60°C per 30 minuti.

Gli enterococchi sono batteri dotati di un basso potere patogeno ma possiedono geni che codificano la resistenza ad alcuni antibiotici, riescono perciò a sopravvivere negli ambienti in cui questi sono ampiamente utilizzati.

Negli ultimi 15 anni, infatti, si sono rivelati spesso causa d'infezioni ospedaliere.

Enterococci are Gram-positive bacteria that are very widespread in nature. They belong to the normal microbial flora of humans and animals, but can also be found in plants and insects.

They are used as indicators of faecal contamination of food and water.

They grow at 10-45°C, in a solution containing up to 6.5% sodium chloride, with pH 9.6, and can survive at 60°C for 30 minutes.

Enterococci are poorly-pathogenic bacteria, but they have genes that encode some antibiotic-resistance, so they can survive in environments in which antibiotics are widely used. Actually, over the last 15 years, they have often caused hospital-acquired infections.

Les entérocoques, bactéries à Gram positif, sont très répandus dans la nature. Ils font partie de la flore microbienne intestinale de l'homme et des animaux, et on les trouve aussi dans les plantes et les insectes. Ils sont utilisés comme indicateurs de contamination fécale de l'eau et des aliments. Ils prolifèrent entre 10 °C et 45 °C, dans une solution contenant jusqu'à 6,5% de chlorure de sodium à pH 9,6, et survivent pendant 30 minutes à une température de 60 °C. Les entérocoques sont des bactéries à faible pouvoir pathogène, mais dont les gènes codifient la résistance à certains antibiotiques, ce qui leur permet de survivre dans les milieux où ceux-ci sont amplement utilisés. Au cours des 15 dernières années, les entérocoques ont en effet souvent été responsables d'infections en milieu hospitalier.

Enterokokken sind Gram-positive Bakterien, die in der Natur stark verbreitet sind. Sie gehören zur mikrobiellen Darmflora der Menschen und Tiere, sind aber auch in Pflanzen und Insekten zu finden. Sie werden als Anzeiger fäkaler Kontaminationen im Wasser und in Nahrungsmitteln verwendet. Sie wachsen bei 10-45°C, in Lösungen mit bis zu 6,5% Natriumchlorid, mit pH 9,6 und überleben 30 Minuten lang einer Temperatur von 60°C. Enterokokken sind Bakterien mit einem niedrigen pathogenen Vermögen, sie besitzen jedoch Gene, welche die Widerstandsfähigkeit gegenüber einiger Antibiotika codieren und deshalb in Bereichen überleben, in denen diese im breiteren Umfang verwendet werden. In den letzten 15 Jahren haben sie sich in der Tat in Krankenhausbereichen oft als Infektionsursache erwiesen.



PREMI E RICONOSCIMENTI
AWARDS AND ACKNOWLEDGEMENTS
PRIX ET RÉCOMPENSES
PREISE UND AUSZEICHNUNGEN

Bios Self-Cleaning® - Bios Antibacterial®

Hanno ricevuto i seguenti riconoscimenti internazionali
 Have received the following International acknowledgements
 Ont reçu les récompenses internationales suivantes:
 Haben folgende internationale Auszeichnungen



2015
A+Award Popular Choice Winner
Categories | Building Products: Façades
 BIOS SELF-CLEANING®



2010
 Selezionata per l'ADI Design Index
 BIOS ANTIBACTERIAL CERAMICS®



2010
AIT Innovation Award
"Architecture and Building", Essen AIT e xia
IntelligenteArchitektur

BIOS ANTIBACTERIAL
 CERAMICS®



2010
AIT Innovation Award
"Architecture and Flooring", Hannover AIT e xia
IntelligenteArchitektur

BIOS ANTIBACTERIAL
 CERAMICS®



2011
Produkt des Jahres
Fliesen&Platten Leserwahl

BIOS ANTIBACTERIAL
 CERAMICS®



2013
Iconic Awards

BIOS ANTIBACTERIAL
 CERAMICS®
 BIOS SELF-CLEANING®



unicolore bios bianco avorio cm 30x60 - 11³/₄"x23⁵/₈"



CERTIFICAZIONI CERTIFICATIONS
CERTIFICATIONS ZERTIFIZIERUNGEN

Le prestazioni di **Bios Antibacterial**[®] sono state verificate e certificate dal Dipartimento di scienze biomediche, sezione di microbiologia, dell'Università di Modena e Reggio Emilia.

The properties of **Bios Antibacterial**[®] have been tested and certified by the Department of Biomedical Science, Microbiology Section, of the University of Modena and Reggio Emilia.

Les performances de **Bios Antibacterial**[®] ont été contrôlées et certifiées par la Division de microbiologie du Département de sciences biomédicales de l'Université de Modène et Reggio d'Émilie.

Die Leistungen von **Bios Antibacterial**[®] wurden vom Departement für biomedizinische Wissenschaften Abteilung Mikrobiologie der Universität Modena und Reggio Emilia geprüft und zertifiziert.

Test method: ISO 27447:2009
Test method for anti-bacterial activity of semiconducting photocatalytic materials
Test method: film adhesion

Material: Ceramic materials
product: Hydroxyl anti-bacterial tile
sample: Test information: Test requested by Catalgromed Padova S.p.A.
Treated specimens: 50x50mm
Non-treated glass: 50x50 mm
All specimens disinfected prior to testing by ethanol
UV intensity (0.001mW/cm²)
time exposure: 6h, Temperature: 25°C
Test bacteria: *Staphylococcus aureus* ATCC 8539 and *Escherichia coli* ATCC 8739

TEST	METHOD	UM	RESULT
Antibacterial Photocatalytic materials: <i>Enterococcus faecalis</i> ATCC 4958	ISO 27447:2009 Film adhesion		
N° bacteria inoculated		Colony	2.000.000
Average number of bacteria non-treated specimens after inoculation		Colony	250.000
RI - Average number of bacteria non-treated specimens after UV irradiation (0,001mW)		Colony	250.000
CI - average photocatalytic antibacterial activity after UV irradiation (0,001mW)		Colony	0
RI - photocatalytic antibacterial activity after UV irradiation (0,001mW)		Log10	4,4
Reduction of bacteria from non treated specimens after UV irradiation (0,001mW)		%	99,9
Antibacterial Photocatalytic materials: <i>E. coli</i> ATCC 8739	ISO 27447:2009 Film adhesion		
N° bacteria inoculated		Colony	250.000
Average number of bacteria non-treated specimens after inoculation		Colony	250.000
RI - Average number of bacteria non-treated specimens after UV irradiation (0,001mW)		Colony	250.000
CI - average photocatalytic antibacterial activity after UV irradiation (0,001mW)		Colony	10
RI - photocatalytic antibacterial activity after UV irradiation (0,001mW)		Log10	4,3
Reduction of bacteria from non treated specimens after UV irradiation (0,001mW)		%	99,9

Scientific advisor
Dott.ssa Carla Sghia
Carla Sghia

Test method: ISO 27447:2009
Test method for anti-bacterial activity of semiconducting photocatalytic materials
Test method: film adhesion

Material: Ceramic materials
product: Hydroxyl anti-bacterial tile
sample: Test information: Test requested by Catalgromed Padova S.p.A.
Treated specimens: 50x50mm
Non-treated glass: 50x50 mm
All specimens disinfected prior to testing by ethanol
UV intensity (0.001mW/cm²)
time exposure: 6h, Temperature: 25°C
Test bacteria: *Pseudomonas aeruginosa* ATCC 27853 and *Enterococcus faecalis* ATCC 4958

TEST	METHOD	UM	RESULT
Antibacterial Photocatalytic materials: <i>Pseudomonas aeruginosa</i> ATCC 27853	ISO 27447:2009 Film adhesion		
N° bacteria inoculated		Colony	2.000.000
Average number of bacteria non-treated specimens after inoculation		Colony	250.000
RI - Average number of bacteria non-treated specimens after UV irradiation (0,001mW)		Colony	250.000
CI - average photocatalytic antibacterial activity after UV irradiation (0,001mW)		Colony	30
RI - photocatalytic antibacterial activity after UV irradiation (0,001mW)		Log10	4,3
Reduction of bacteria from non treated specimens after UV irradiation (0,001mW)		%	99,9
Antibacterial Photocatalytic materials: <i>Enterococcus faecalis</i> ATCC 4958	ISO 27447:2009 Film adhesion		
N° bacteria inoculated		Colony	2.000.000
Average number of bacteria non-treated specimens after inoculation		Colony	250.000
RI - Average number of bacteria non-treated specimens after UV irradiation (0,001mW)		Colony	250.000
CI - average photocatalytic antibacterial activity after UV irradiation (0,001mW)		Colony	30
RI - photocatalytic antibacterial activity after UV irradiation (0,001mW)		Log10	4,3
Reduction of bacteria from non treated specimens after UV irradiation (0,001mW)		%	99,9

Scientific advisor
Dott.ssa Carla Sghia
Carla Sghia



Università degli Studi di Modena e Reggio Emilia

*Dipartimento di Scienze Biomediche
Sezione di Microbiologia*

1 In data 28/03/2007 si è ricevuto da Casalgrande Padana spa il campione siglato:

Campione 4 – Bianco A Tab 30x60
Tono AA - Calibro 5
Produzione 26/03/2007

2 Materiale fornito per la costruzione del

**"CENTRO DI MEDICINA RIGENERATIVA"
di Modena**

3 È stata saggiata l'attività antibatterica, espressa in percentuale di abbattimento della carica microbica, del campione nei confronti di:

<i>Staphylococcus aureus</i>	ATCC	6538
<i>Enterococcus faecalis</i>	ATCC	29212
<i>Escherichia coli</i>	ATCC	25922
<i>Pseudomonas aeruginosa</i>	ATCC	27859

4 L'attività antibatterica del campione è risultata essere del **99.9%** nei confronti dei germi testati.

RESPONSABILE SCIENTIFICO
Prof. Giuliano Manicardi

Via G. Campi 287, 41100 Modena, Italy-
Tel.: ++39 59-2055469, 2055795- Fax. 059-2055483-Email: segrdsd@unimo.it

- 1 On March 28, 2007 Casalgrande Padana spa sent us the following sample:
2. This is one of the materials used for the building of the
3. We have analysed the antibacterial activity of the sample. It is expressed in terms of percent of abatement of the microbial load of the sample. We analysed the following:
4. The sample's antibacterial activity turned out to be 99.9% based on the germs we tested.

1. Le 28 mars 2007 la société Casalgrande Padana spa nous a fait parvenir l'échantillon suivant :
2. Il s'agit d'un des matériaux utilisés pour la réalisation du
3. Nous avons analysé l'activité antibactérienne de l'échantillon, exprimée en pourcentage de réduction de la charge microbienne de l'échantillon. Nous avons analysé les éléments suivants :
4. L'activité antibactérienne de l'échantillon, considérant les germes ayant fait l'objet de notre essai, est de 99,9%.

1. Am 28. März 2007 haben wir eine Stichprobe von Casalgrande Padana spa erhalten die folgendermaßen gekennzeichnet war:
2. Das Material dient dem Bau des
3. Es wurde die antibakterielle Wirksamkeit getestet, unter der prozentualen Angabe der antibakteriellen Reduktion des Musters, in Bezug auf:
4. Die antibakterielle Wirksamkeit des Musters in Bezug auf die getesteten Bakterien betrug 99,9%.

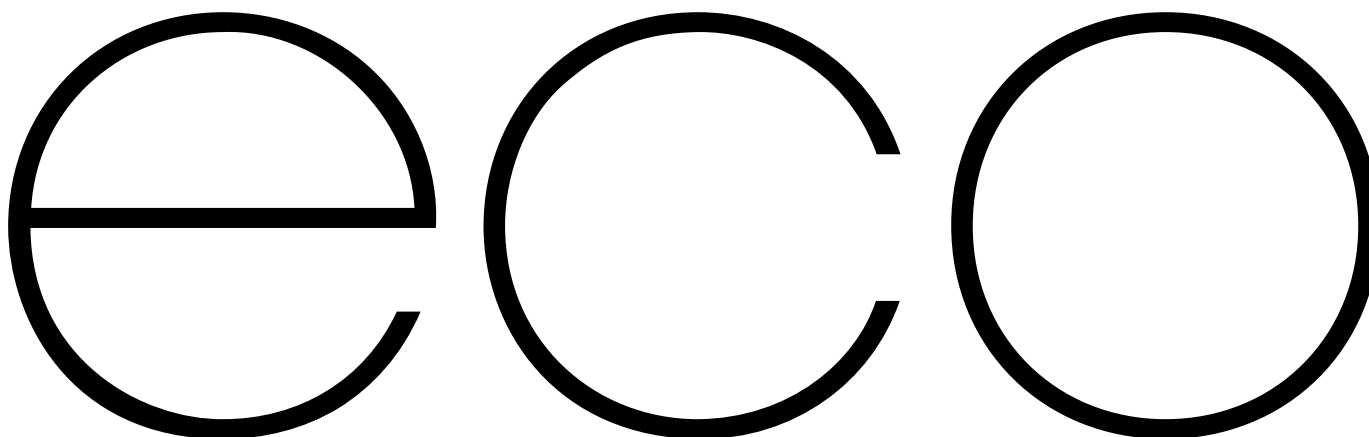
**ECOSOSTENIBILITÀ**

come filosofia di riferimento per realizzare prodotti ceramici evoluti, in grado di rispondere alla domanda più qualificata proveniente dal settore dell'architettura. Elementi in grès porcellanato prodotti da Casalgrande Padana attraverso un processo virtuoso e attento alla tutela dell'ambiente, capaci di coniugare libertà e flessibilità creativa con i più elevati contenuti tecnologici e prestazionali.

ECO-SUSTAINABILITY

as a reference philosophy for creating evolved ceramic products able to satisfy the most qualified demands from the sphere of architecture. Porcelain stoneware tiles produced by Casalgrande Padana through a virtuous process with safeguarding the environment as a prime concern, products that combine versatility and boundless scope for creativeness with the highest technological and performance specifications.

ÉCO-DURABILITÉ

comme philosophie de référence pour réaliser des produits céramiques évolués, en mesure de satisfaire la demande la plus qualifiée, provenant du secteur de l'architecture. Éléments en grès cérame produits par Casalgrande Padana à travers un procédé respectueux et soucieux de l'environnement, capables d'allier liberté et flexibilité créative aux plus hauts contenus technologiques et de performances.

ÖKO-NACHHALTIGKEIT

als Bezugsphilosophie, um ausgereifte Keramikprodukte zu realisieren, die in der Lage sind, der qualifiziertesten Nachfrage gerecht zu werden, die aus dem Sektor der Architektur kommt. Elemente aus Feinsteinzug, von Casalgrande Padana durch einen virtuoson und auf den Umweltschutz achtenden Prozess hergestellt, die in der Lage sind, kreative Freiheit und Flexibilität mit den höchsten technologischen und leistungsmäßigen Eigenschaften zu verbinden.



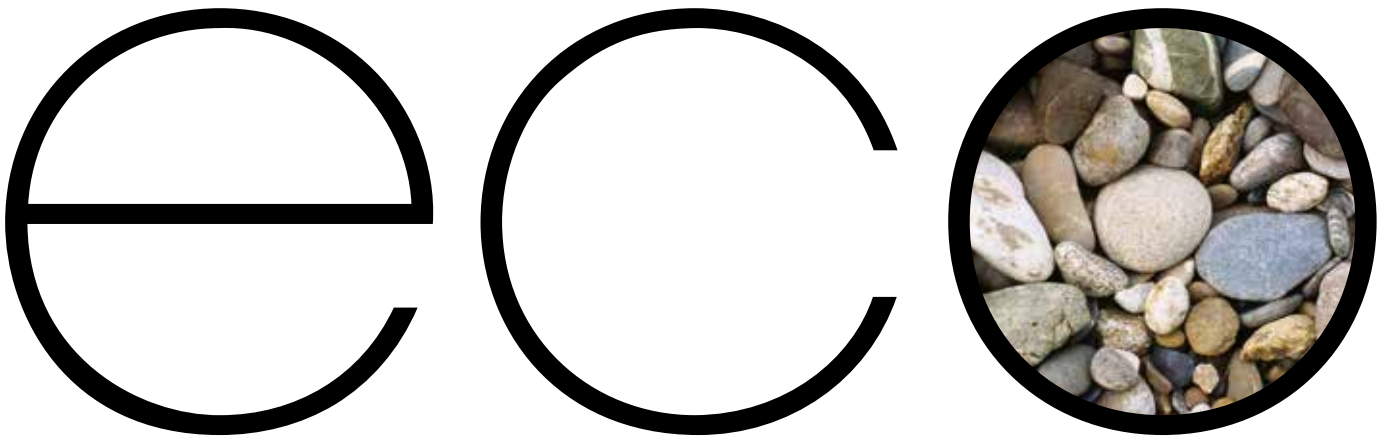

eco**stone** éco**pierre** öko**stein**

pietra

eco**pietra**

44	pietre di paragone
56	amazzoneia
62	chalon
68	limestone
74	meteor
82	mineral chrom
88	pietra baugé
94	pietre di sardegna
106	stonewash
112	terre toscane
120	pietre etrusche
128	basaltina
138	pietra blue
142	pietra piacentina
146	kerblock
150	natural slate
154	titano
160	ardesia
164	lavagna
168	patio
172	agorà



PIETRA

Roccia da costruzione o decorazione. La composizione mineralogica molto varia di questo gruppo di materiali viene classificata in due grandi categorie: Rocce tenere o poco compatte, tra le quali le sedimentarie [calcareniti, arenarie a cemento calcareo ecc.] e le piroclastiche come i tufi e i peperini; Rocce dure o compatte, tra le quali le pietre a spacco naturale [quarziti, micascisti, gneiss, lastroidi, ardesie ecc.] e alcune vulcaniti, come i basalti, le trachiti e i leucititi.

STONE

Rock used for building or decorating purposes. The extremely varied mineralogical composition of this group of materials is divided into two large categories: Soft rocks or not very compact, including sedimentary rock [calcarenites, limy cement type sandstones, etc.] and pyroclastic materials like tuffs and peperino rocks; Hard rocks or compact ones, such as naturally split stones [quarzites, mica schists, gneiss, slab-structured rocks, slates, etc.] and certain volcanites, such as basalts, trachytes and leukocytes.

pietre di paragone grigio aitos

pietre di paragone

PIETRE NATIVE



grigio aitos cm 90x180 - 35³/₈"x70⁷/₈"

COLORI COLOURS COULEURS FARBEN

onsernone

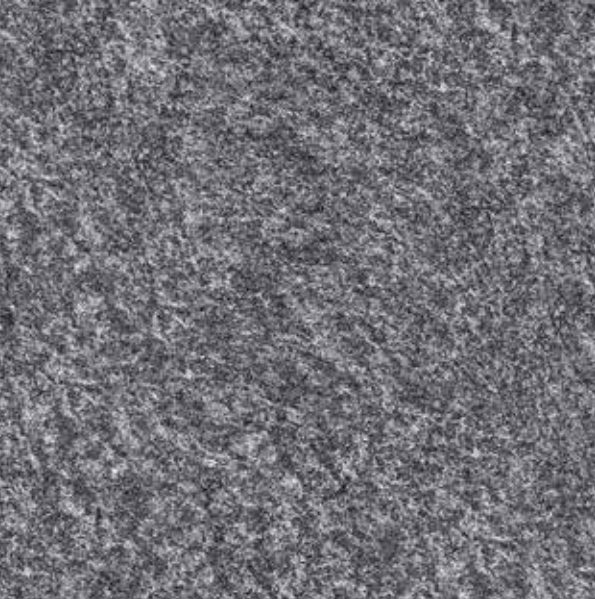

gré grigio



gré bianco



pietra del cardoso



black pearl



grigio tao

pietre di paragone

PIETRE NATIVE

gré nero



grigio aitos



onsernone *grip* cm 60x120 - 23⁵/₈"x47¹/₄"

COLORI COLOURS COULEURS FARBEN

pietra piacentina new



vals



jura grigia



jura beige



pietra di vicenza



luni

SUPERFICI SURFACES
SURFACES OBERFLÄCHEN

pietre di paragone

PIETRE NATIVE

lappata

**naturale matt
naturelle matt
R10**

grip R12

FORMATI SIZES FORMATS FORMATE

Formati Sizes Formats Formate	cm 30x60 11 ³ / ₄ "x23 ⁵ / ₈ "	cm 60x60 23 ⁵ / ₈ "x23 ⁵ / ₈ "	cm 60x60 23 ⁵ / ₈ "x23 ⁵ / ₈ "	cm 60x120 23 ⁵ / ₈ "x47 ¹ / ₄ "	cm 45x90 17 ³ / ₄ "x35 ³ / ₈ "	cm 45x90 17 ³ / ₄ "x35 ³ / ₈ "	cm 90x90 35 ³ / ₈ "x35 ³ / ₈ "	cm 90x180 35 ³ / ₈ "x70 ⁷ / ₈ "
Black Pearl	●	●		●		●	●	●
Pietra Plasentina New	● ●	● ●		● ●*		● ●*	● ●*	● ●*
Pietra del Cardoso	● ●	● ●		● ●*		● ●*	● ●*	● ●*
Onsernone	● ●	● ●		● ●*	●			
Vals	● ●	● ●		● ●*				
Grigio Aitos	● ●	● ●		● ●*		● ●*	● ●*	● ●*
Grigio Tao	● ●	● ●		● ●*		● ●*	● ●*	● ●*
Jura Grigia	● ● ●	● ● ●						
Jura Beige	● ● ●	● ● ●						
Gré Grigio	● ●	● ●	●	● ●*				
Gré Nero	● ●	● ●		● ●*				
Gré Bianco	● ●	● ●	●	● ●*				
Pietra di Vicenza	● ●	● ●		● ●*		● ●*	● ●*	● ●*
Luni	● ●	● ●		● ●*		● ●*	● ●*	● ●*
▽ *	mm 10	mm 10	mm 20	mm 10	mm 20	mm 10	mm 10	mm10
▲	mm 9							



Stonizzazione accentuata
Shade variation accentuated
Variations d'ombre forte
Farbtonvarianten Akzentuiert

* Grip su richiesta Grip on request Grip sur demande Grip Auf Anfrage können

Rettificate in un unico calibro Rectified version in a single caliber
Rectifiés en un unique calibre Boden Sie in einem einzigen Kaliber

● Naturale Matt Naturelle Matt **R10**
(Ad eccezione di: Except for: À l'exception de:
Mit Ausnahme von: **Black Pearl**)

●** Naturale Matt Naturelle Matt

● Grip **R12**

● Lappata

Caratteristiche tecniche e imballi a pagina: Technical features and packing on page:

Caractéristiques techniques et emballages à la page: Technische Eigenschaften und Verpackungen auf Seite: **498**

PEZZI SPECIALI TRIMS ACCESSOIRES FORMSTÜCKE

Battiscopa Bullnose
Plinthe à bord arrondi
Stehsokkel
cm 9x90 - 3¹/₂"x35³/₈"
cm 9x60 - 3¹/₂"x23⁵/₈"



Gradino Step tread
Nez de marche
Stufenplatte
cm 30x60 - 11³/₄"x23⁵/₈"

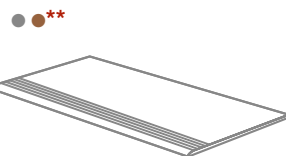

Gradone (assemblato)
cm 120x33 - 47¹/₄"x13"

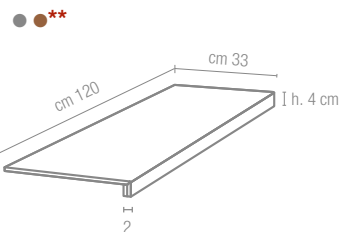

Angolare (assemblato)
cm 120x33 - 35³/₈"x47¹/₄"

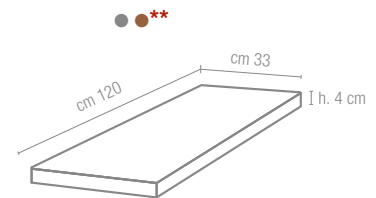

** Ad eccezione di: Except for à l'exception de: Mit Ausnahme von: **Black Pearl**

K Lastre K_{ontinua}
 K_{ontinua} Slabs
 Dalles K_{ontinua}
 K_{ontinua} Platten



cm 60x120
 23⁵/₈"x47¹/₄"

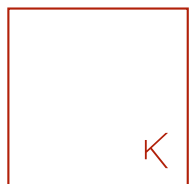

cm 120x120
 47¹/₄"x47¹/₄"

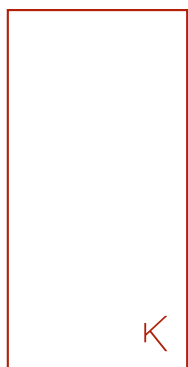

cm 120x240
 47¹/₄"x94¹/₂"

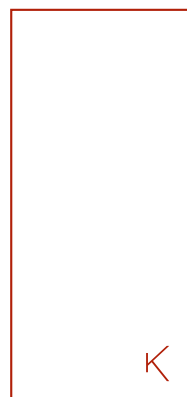

cm 120x260
 47¹/₄"x102³/₈"

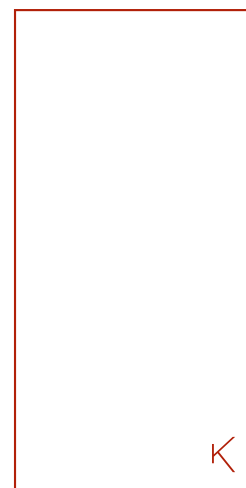

cm 160x320
 63"x126"



mm 6,5

mm 10
 mm 6,5

mm 6,5

mm 6,5

mm 12

DECORI DECORS DÉCORS DEKORE

mosaico 6x6*

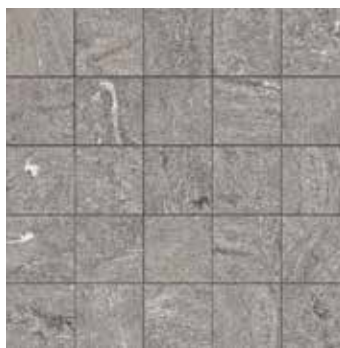

cm 30x30 - 11³/₄"x11³/₄"
 tessera **cm 6x6** - 2³/₈"x2³/₈"
 su rete on net sur trame auf Netz

▼ mm 10 K_{ontinua} mm 6,5
 ▲

mosaico 10x10*



cm 30x30 - 11³/₄"x11³/₄"
 tessera **cm 10x10** - 4"x4"
 su rete on net sur trame auf Netz

* Disponibile in tutti i colori della serie, superficie naturale e grip
 Available in all the colours of the series, matt and grip surface
 Disponible dans toutes les couleurs de la série, surface naturelle et grip
 Verfügbar in allen Farben, matte und grip Oberfläche

DECORI DECORS DÉCORS DEKORE

diagonal



cm 120x240 47¹/₄"x 94¹/₂"

▼
▲ KONTINUA mm 6,5

Decoro abbinabile con
le collezioni Pietre di Paragone,
Pietre di Sardegna e Marmoker
Decor matching the Pietre di
Paragone, Pietre di Sardegna
and Marmoker collections
Décor pouvant être associé aux
collections Pietre di Paragone,
Pietre di Sardegna et Marmoker
Dekor kombinierbar mit den
Kollektionen Pietre di Paragone,
Pietre di Sardegna und Marmoker



diagonal cm 120x240 - 47¹/₄"x94¹/₂"

pietre di paragone

PIETRE NATIVE

optical

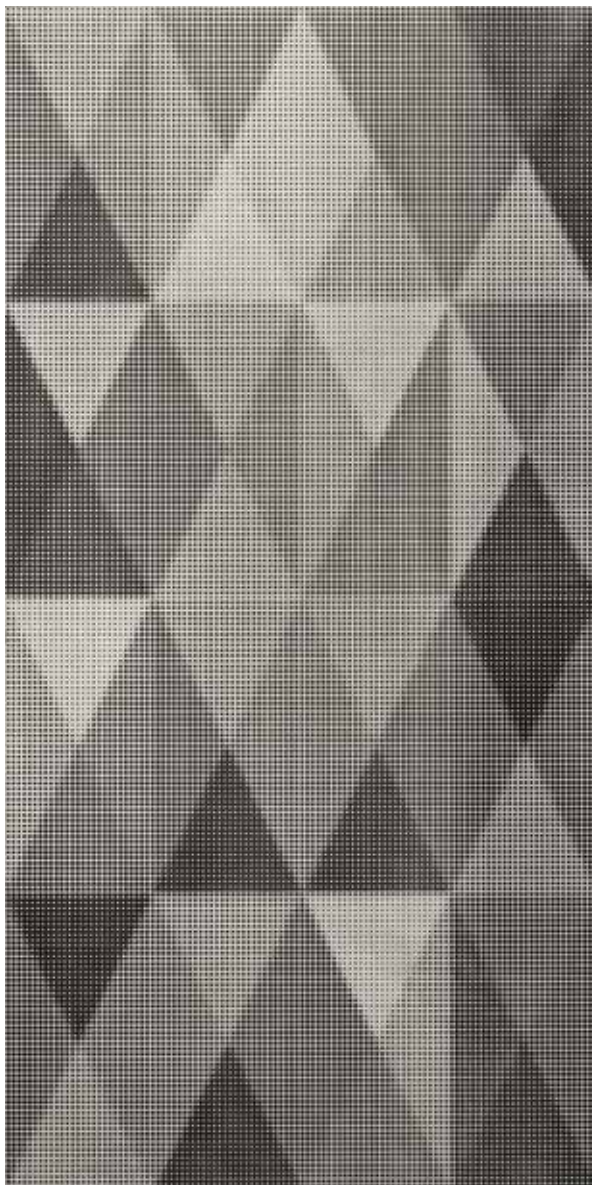

cm 120x240 47¹/₄"x 94¹/₂"

 Kontinua mm 6,5



Decoro abbinabile con
 le collezioni Pietre di Paragone,
 Pietre di Sardegna e Marmoker
 Decor matching the Pietre di
 Paragone, Pietre di Sardegna
 and Marmoker collections
 Décor pouvant être associé aux
 collections Pietre di Paragone,
 Pietre di Sardegna et Marmoker
 Dekor kombinierbar mit den
 Kollektionen Pietre di Paragone,
 Pietre di Sardegna und Marmoker



optical cm 120x240 - 47¹/₄"x94¹/₂"

DECORI DECORS DÉCORS DEKORE

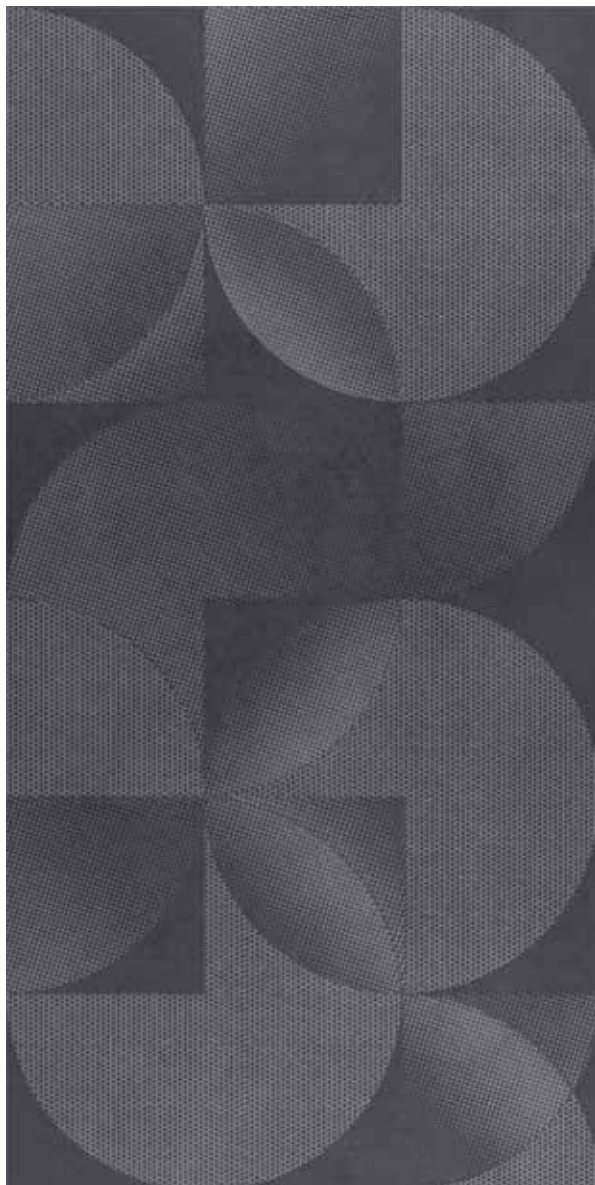
round square

cm 120x240 47¹/₄"x 94¹/₂"
 Kontinua mm 6,5

Decoro abbinabile con
le collezioni Pietre di Paragone,
Pietre di Sardegna e Marmoker
Decor matching the Pietre di
Paragone, Pietre di Sardegna
and Marmoker collections
Décor pouvant être associé aux
collections Pietre di Paragone,
Pietre di Sardegna et Marmoker
Dekor kombinierbar mit den
Kollektionen Pietre di Paragone,
Pietre di Sardegna und Marmoker



pietra del cardoso cm 120x240 - 47¹/₄"x94¹/₂"
round square cm 120x240 - 47¹/₄"x94¹/₂"

pietre di paragone

PIETRE NATIVE

golden paint

cm 120x240 47¹/₄"x 94¹/₂"

 Kontinua mm 6,5

Decoro abbinabile con
le collezioni Pietre di Paragone,
Pietre di Sardegna e Marmoker
Decor matching the Pietre di
Paragone, Pietre di Sardegna
and Marmoker collections
Décor pouvant être associé aux
collections Pietre di Paragone,
Pietre di Sardegna et Marmoker
Dekor kombinierbar mit den
Kollektionen Pietre di Paragone,
Pietre di Sardegna und Marmoker



pietra del cardoso cm 120x240 - 47¹/₄"x94¹/₂"
golden paint cm 120x240 - 47¹/₄"x94¹/₂"

amazzonia dragon black

amazzonia

PIETRE NATIVE



dragon black cm 45x90 - 17³/₄"x35³/₈"

COLORI COLOURS COULEURS FARBEN

dragon black



dragon green



dragon grey



dragon chocolate



dragon brown



eldorado

amazzonia

PIETRE NATIVE

SUPERFICI SURFACES
SURFACES OBERFLÄCHEN

naturale matt
naturelle matt
R10 A











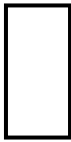

grip R12 A+B+C

dragon white





dragon beige

FORMATI SIZES FORMATS FORMATE

Formati Sizes Formats Formate	 cm 30x30 11 ³ / ₄ "x11 ³ / ₄ "	 cm 45x45 17 ³ / ₄ "x17 ³ / ₄ "	 cm 30x60 11 ³ / ₄ "x23 ⁵ / ₈ "	 cm 60x60 23 ⁵ / ₈ "x23 ⁵ / ₈ "	 cm 45x90 17 ³ / ₄ "x35 ³ / ₈ "	 cm 45x90 17 ³ / ₄ "x35 ³ / ₈ "
Superfici Surfaces Surfaces Oberflächen						
	mm 9	mm 10	mm 10 mm 9 mm 9*	mm 10	mm 10	mm 20**



Stonizzazione accentuata
Shade variation accentuated
Variations d'ombre forte
Farbtonvarianten Akzentuiert

 Naturale Matt Naturelle Matt **R10 A**
 Grip **R12 A+B+C**

Rettificate in un unico calibro Rectified version in a single caliber Rectifiés en un unique calibre Boden Sie in einem einzigen Kaliber

Nel caso di combinazioni di formati di spessori diversi, specificarlo espressamente nell'ordine
Please specify in your order if you wish to purchase formats including more than one thickness
Prière de spécifier dans votre commande si vous souhaitez acheter des formats avec différentes épaisseurs
Bitte weisen Sie im Bestellungsformular ausdrücklich darauf hin, wenn Sie Formatkombinationen mit verschiedenen Stärken wünschen

* Non rettificato Unrectified
Non rectifié Nicht kalibriert

** **Dragon Black, Dragon Grey, Dragon Beige, Dragon White, Dragon Brown**
Superficie grip Grip surface
Surface grip Grip Oberfläche

Caratteristiche tecniche e imballi a pagina: Technical features and packing on page: Caractéristiques techniques et emballages à la page: Technische Eigenschaften und Verpackungen auf Seite: **498**

DECORI DECORS DÉCORS DEKORE

mosaico 3x3*

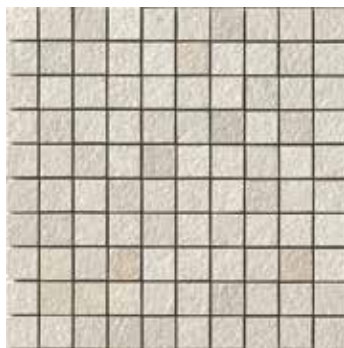

cm 30x30 - 11³/₄"x11³/₄"
tessera **cm 3x3** - 1¹/₈"x1¹/₈"
su rete on net sur trame auf Netz

mosaico 6x6*



cm 30x30 - 11³/₄"x11³/₄"
tessera **cm 6x6** - 2³/₈"x2³/₈"
su rete on net sur trame auf Netz

composizione A*

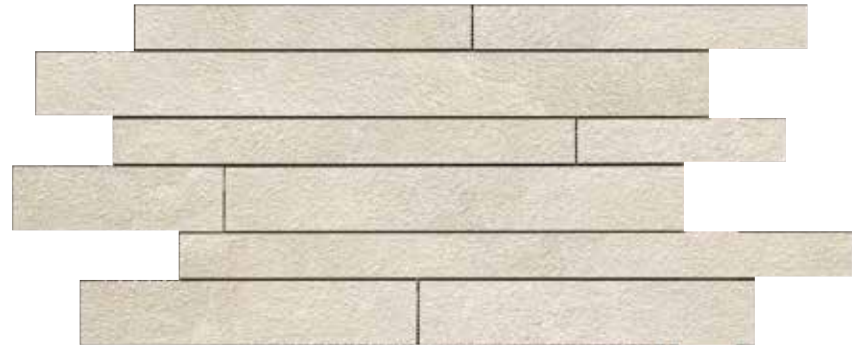

cm 30x60 - 11³/₄"x23⁵/₈"
su rete on net sur trame auf Netz

* Disponibile in tutti i colori della serie su superficie naturale. A richiesta su superficie grip. Available in all the matt colours. On request also on grip surface.
Disponible dans toutes les couleurs pour la surface naturelle. Sur demande la finition grip. Verfügbar in allen Farben der Serie, matte Oberfläche. Auf Anfrage grip Oberfläche.

PEZZI SPECIALI TRIMS
ACCESSOIRES FORMSTÜCKE

▲ 2pcs  45°

amazzonia

PIETRE NATIVE

Battiscopa Bullnose
Plinthe à bord arrondi
Stehsockel
cm 9x45 - 3 1/2"x17 3/4"
cm 9x60 - 3 1/2"x23 5/8"



Bordo
Terminale Gradino B.C.
cm 9x30 - 3 1/2"x11 3/4"
cm 9x45 - 3 1/2"x17 3/4"



Bordo
Terminale Gradino B.C.
cm 9x60 - 3 1/2"x23 5/8"

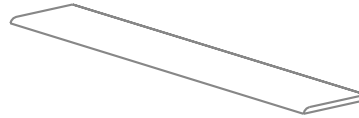

Art. 9610 Bordo ▲
cm 33x90 - 1 1/4"x35 3/8"

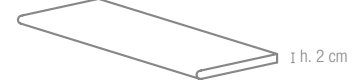

Art. 9630 Bordo ▲
cm 22,5x90 - 8 7/8"x35 3/8"

Terminale Pezzo unico pressato
Pièce unique pressée
Pressed single piece
Gepresstes Einzelsück
cm 15x30x3,5 - 5 7/8"x11 3/4"x1 3/8"

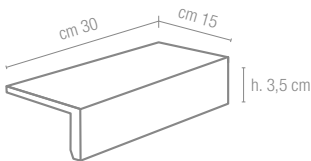

Gradino Step tread
Nez de marche Stufenplatte
cm 45x45 - 17 3/4"x17 3/4"
cm 30x60 - 11 3/4"x23 5/8"

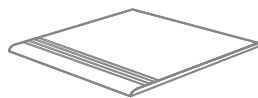

Art. 9617
Bordo angolare esterno ▲
cm 33x45 - 1 1/4"x17 3/4"



Art. 9637
Bordo angolare esterno ▲
cm 22,5x45 - 8 7/8"x17 3/4"

Art. 9618
Bordo angolare interno ▲
cm 33x45 - 1 1/4"x17 3/4"



Art. 9638
Bordo angolare interno ▲
cm 22,5x45 - 8 7/8"x17 3/4"

Art. 9883 Griglia
cm 30x40x2 - 1 1/4"x15 3/4"x 3/4"

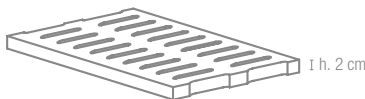

Art. 9884 Griglia angolare ▲
cm 30x40x2 - 1 1/4"x15 3/4"x 3/4"

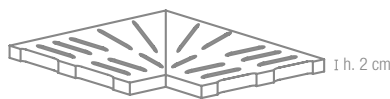

Art. 9885 Griglia
cm 13x40x2 - 5 1/8"x15 3/4"x 3/4"

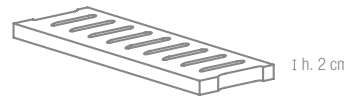

Art. 9886 Griglia angolare ▲
cm 13x40x2 - 5 1/8"x15 3/4"x 3/4"

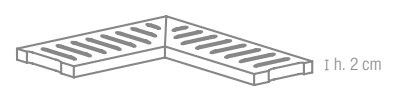

Gradone (assemblato)
cm 60x33 - 23 5/8"x13"

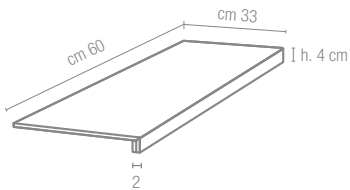

Angolare (assemblato)
cm 60x33 - 23 5/8"x13"

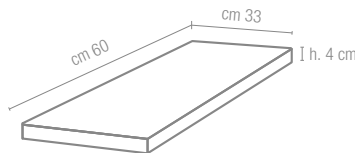

Art. 9900
Angolo terminale
gradino B.C.
cm 9x9 - 3 1/2"x3 1/2"



Art. 9830
cm 30 - 1 1/4"

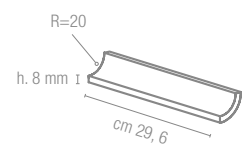

Art. 9833
cm 2x2 - 3/4"x3/4"



Art. 9834
cm 5x5x2 - 1 7/8"x 1 7/8"x3/4"

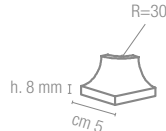

Art. 9835 grip
cm 30 - 1 1/4"

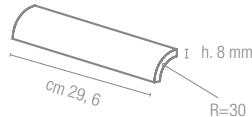

Art. 9837 grip
cm 3x3 - 1 1/8"x 1 1/8"



Art. 9838 grip
cm 5x3x2 - 1 7/8"x 1 1/8"x 3/4"

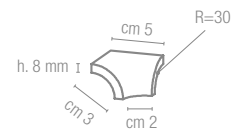

Art. 9660 Pool Wave
cm 60x25 - 23 5/8"x9 7/8"

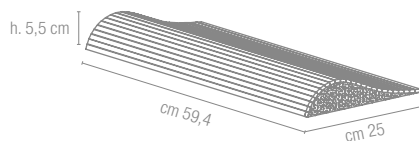

Art. 9667 Pool Wave
cm 30x30 - 1 1/4"x11 3/4"

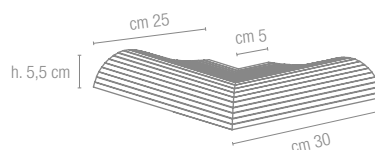

Art. 9668 Pool Wave
cm 30x30 - 1 1/4"x11 3/4"

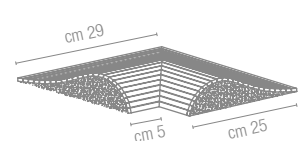

chalon cream

chalon

PIETRE NATIVE



chalon cream cm 60x60 - 23⁵/₈"x23⁵/₈"

COLORI COLOURS COULEURS FARBEN

chalon kaki



chalon beige



chalon grey



chalon cream

SUPERFICI SURFACES SURFACES OBERFLÄCHEN

chalon







PIETRE NATIVE

lappata



**naturale matt
naturelle matt
R10**

grip R12

FORMATI SIZES FORMATS FORMATE

Formati Sizes Formats Formate	 cm 30x60 11 ³ / ₄ "x23 ⁵ / ₈ "	 cm 60x60 23 ⁵ / ₈ "x23 ⁵ / ₈ "	 cm 60x120 23 ⁵ / ₈ "x47 ¹ / ₄ "
Superfici Surfaces Surfaces Oberflächen			
	mm 10 mm 9	mm 10	mm 10

 Stonizzazione accentuata
 Shade variation accentuated
 Variations d'ombre forte
 Farbtonvarianten Akzentuiert

 Naturale Matt Naturelle Matt **R10**
 Lappata
 Grip **R12**

Rettificata in un unico calibro Rectified version in a single caliber Rectifiés en un unique calibre Boden Sie in einem einzigen Kaliber

Caratteristiche tecniche e imballi a pagina: Technical features and packing on page: Caractéristiques techniques et emballages à la page: Technische Eigenschaften und Verpackungen auf Seite: **498**



chalon beige *grip* cm 30x60 - 11³/₄"x23⁵/₈"

PEZZI SPECIALI TRIMS ACCESSOIRES FORMSTÜCKE

Battiscopa Bullnose
Plinthe à bord arrondi
Stehsockel
cm 9x60 - 3¹/₂"x23⁵/₈"



Gradino Step tread
Nez de marche
Stufenplatte
cm 30x60 - 11³/₄"x23⁵/₈"

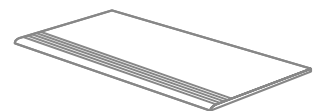

Gradone (assemblato)
cm 120x33 - 47¹/₄"x13"

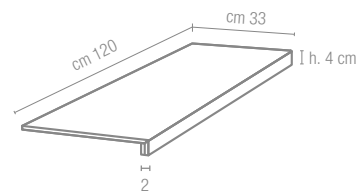

Angolare (assemblato)
cm 120x33 - 47¹/₄"x13"

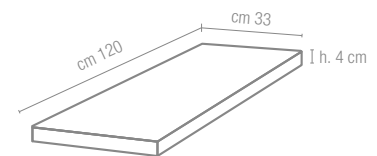

DECORI DECORS DÉCORS DEKORE

chalon

PIETRE NATIVE

mosaico 6x6*



cm 30x30 - 11³/₄"x11³/₄"
 tessera **cm 6x6** - 2³/₈"x2³/₈"
su rete on net sur trame auf Netz

mosaico 10x10*



cm 30x30 - 11³/₄"x11³/₄"
 tessera **cm 10x10** - 4"x4"
su rete on net sur trame auf Netz

* Disponibile in tutti i colori della serie su superficie naturale. A richiesta su superficie grip e lappata Available in all the matt colours. On request also on grip and lappata surface
 Disponible dans toutes les couleurs pour la surface naturelle. Sur demande la finition grip et lappata Verfügbar in allen Farben der Serie, matte Oberfläche. Auf Anfrage grip und lappata Oberfläche



chalon grey cm 30x60 - 11³/₄"x23⁵/₈"

limestone beige

limestone

PIETRE NATIVE



limestone beige cm 60x60 - 23⁵/₈"x23⁵/₈"

COLORI COLOURS COULEURS FARBEN

limestone nero



limestone grigio



limestone beige





limestone

PIETRE NATIVE



limestone nero cm 60x60 - 23⁵/₈"x23⁵/₈"

FORMATI SIZES FORMATS FORMATE

Formati Sizes Formats Formate		
	cm 30x60 11 ³ / ₄ "x23 ⁵ / ₈ "	cm 60x60 23 ⁵ / ₈ "x23 ⁵ / ₈ "
Superfici Surfaces Surfaces Oberflächen	●	●
	mm 10 mm 9	mm 10
 Stonalizzazione accentuata Shade variation accentuated Variations d'ombre forte Farbtonvarianten Akzentuiert	● Naturale Matt Naturelle Matt R10	

Rettificate in un unico calibro Rectified version in a single caliber Rectifiés en un unique calibre Boden Sie in einem einzigen Kaliber

Caratteristiche tecniche e imballi a pagina: Technical features and packing on page: Caractéristiques techniques et emballages à la page: Technische Eigenschaften und Verpackungen auf Seite: **498**

PEZZI SPECIALI TRIMS ACCESSOIRES FORMSTÜCKE

Battiscopa Bullnose
Plinthe à bord arrondi
Stehsockel
cm 9x60 - 3¹/₂"x23⁵/₈"



Gradino Step tread
Nez de marche
Stufenplatte
cm 30x60 - 11³/₄"x23⁵/₈"

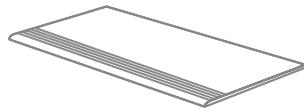

Gradone (assemblato)
cm 60x33 - 23⁵/₈"x13"

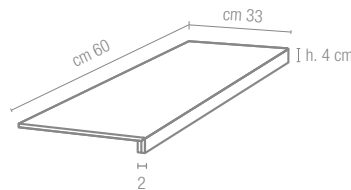

Angolare (assemblato)
cm 60x33 - 23⁵/₈"x47¹/₄"

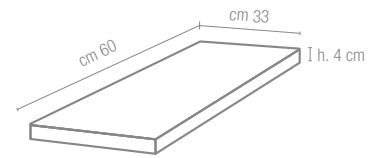

DECORI DECORS DÉCORS DEKORE

mosaico 6x6*



cm 30x30 - 11³/₄"x11³/₄"
tessera cm 6x6 - 2³/₈"x2³/₈"
su rete on net sur trame auf Netz

mosaico 10x10*



cm 30x30 - 11³/₄"x11³/₄"
tessera cm 10x10 - 4"x4"
su rete on net sur trame auf Netz

* Disponibile in tutti i colori della serie Available in all the colours of the series Disponible dans tous les couleurs de la série Verfügbar in allen Farben

limestone

PIETRE NATIVE



limestone beige cm 60x60 - 23⁵/₈"x23⁵/₈"
mosaico 6x6 limestone beige cm 30x30 - 11³/₄"x11³/₄"

meteor grigio

meteor

PIETRE NATIVE



meteor grigio cm 30x30 - 11³/₄"x11³/₄"

COLORI COLOURS COULEURS FARBEN

meteor grafite



meteor nero



meteor grigio



meteor rosso



meteor brown



meteor noce

meteor

PIETRE NATIVE

meteor perla



meteor bianco











meteor beige



meteor almond

FORMATI SIZES FORMATS FORMATE

Formati Sizes Formats Formate 17 ³ / ₄ "x35 ³ / ₈ "	 cm 15x15 5 ⁷ / ₈ "x5 ⁷ / ₈ "	 cm 30x30 11 ³ / ₄ "x11 ³ / ₄ "	 cm 40x40 15 ³ / ₄ "x15 ³ / ₄ "	 cm 45x45 17 ³ / ₄ "x17 ³ / ₄ "	 cm 15x60 5 ⁷ / ₈ "x23 ⁵ / ₈ "	 cm 30x60 11 ³ / ₄ "x23 ⁵ / ₈ "	 cm 60x60 23 ⁵ / ₈ "x23 ⁵ / ₈ "
Superfici Surfaces Surfaces Oberflächen	●	● ●	● ●	● ●	●	● ●	● ●
	mm 9	mm 9 mm 8*	mm 9	mm 9*	mm 9	mm 10 mm 9 mm 9*	mm 10
 Stonalizzazione media Shade variation medium Variations d'ombre moyenne Farbtonvarianten Mittel							● Naturale Matt Naturelle Matt R10 ● Lappata

* Solo naturale, versione non rettificata e solo nei colori: Only matt, not rectified version and only in the colours:

Seulement naturel, version non rectifiée et seulement dans les couleurs : Nur matt, in der nicht rektifizierte Version und in die Farben: **Nero, Grigio, Noce, Beige, Almond, Bianco**

Rettificata in un unico calibro Rectified version in a single caliber Rectifiés en un unique calibre Boden Sie in einem einzigen Kaliber

Nel caso di combinazioni di formati di spessori diversi, specificarlo espressamente nell'ordine Please specify in your order if you wish to purchase formats including more than one thickness
Prière de spécifier dans votre commande si vous souhaitez acheter des formats avec différentes épaisseurs Bitte weisen Sie im Bestellungsformular ausdrücklich darauf hin, wenn Sie
Formatkombinationen mit verschiedenen Stärken wünschen

Caratteristiche tecniche e imballi a pagina: Technical features and packing on page: Caractéristiques techniques et emballages à la page: Technische Eigenschaften und Verpackungen auf Seite: **498**

PEZZI SPECIALI TRIMS ACCESSOIRES FORMSTÜCKE

Battiscopa Bullnose
Plinthe à bord arrondi
Stehsockel
cm 9x30 - 3¹/₂"x11³/₄"
cm 9x40 - 3¹/₂"x15³/₄"
cm 9x45 - 3¹/₂"x17³/₄"
cm 9x60 - 3¹/₂"x23⁵/₈"



Gradino Step tread
Nez de marche **Stufenplatte**
cm 30x30 - 11³/₄"x11³/₄"
cm 30x60 - 11³/₄"x23⁵/₈"
cm 40x40 - 15³/₄"x15³/₄"

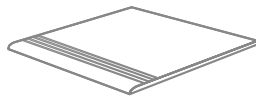

Gradone (assemblato)
cm 30x33 - 11³/₄"x13"
cm 60x33 - 23⁵/₈"x13"

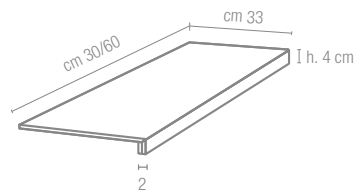

Angolare (assemblato)
cm 30x33 - 11³/₄"x13"
cm 60x33 - 23⁵/₈"x13"

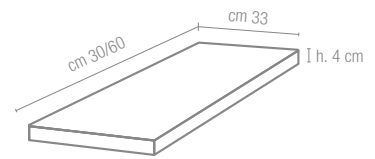

Terminale Pezzo incollato
Glued piece Pièce collée
Geklebter Stück
cm 15x30x5 - 5⁷/₈"x11³/₄"x2"

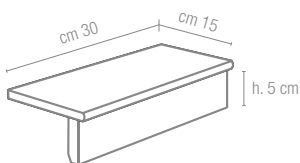

Tozzetto
Insert
Cabochoon
Einleger
cm 9x9 - 3¹/₂"x3¹/₂"

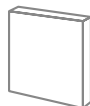

Listello
Listel
Listel
Zeilerleiste
cm 9x30 - 3¹/₂"x11³/₄"



Scalino
e scalino angolare
cm 30x33 - 11³/₄"x13"

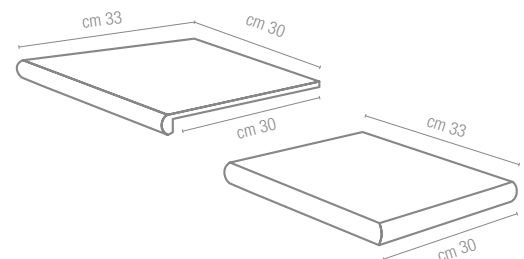

SUPERFICI **SURFACES** SURFACES **OBERFLÄCHEN**

meteor

PIETRE NATIVE

lappata

**naturale matt
naturelle matt
R10**

DECORI DECORS DÉCORS DEKORE

decoro A*

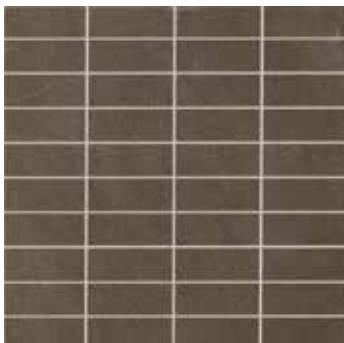

cm 30x30 - $11\frac{3}{4}'' \times 11\frac{3}{4}''$
 tessera **cm 2,5x7,5** - $1'' \times 3''$

decoro B*



cm 30x30 - $11\frac{3}{4}'' \times 11\frac{3}{4}''$
 tessera **cm 7,5x7,5** - $3'' \times 3''$

decoro C*



cm 30x60 - $11\frac{3}{4}'' \times 23\frac{5}{8}''$
 listello **cm 1,5x60** - $\frac{1}{2}'' \times 23\frac{5}{8}''$

mosaico 3x3*



cm 30x30 - $11\frac{3}{4}'' \times 11\frac{3}{4}''$
 tessera **cm 3x3** - $1\frac{1}{8}'' \times 1\frac{1}{8}''$
su rete on net sur trame auf Netz

mosaico 6x6*



cm 30x30 - $11\frac{3}{4}'' \times 11\frac{3}{4}''$
 tessera **cm 6x6** - $2\frac{3}{8}'' \times 2\frac{3}{8}''$
su rete on net sur trame auf Netz

decoro D*



cm 30x60 - $11\frac{3}{4}'' \times 23\frac{5}{8}''$
 listello **cm 7,5x60** - $3'' \times 23\frac{5}{8}''$

* Disponibile in tutti i colori della serie, superficie naturale e lappata Available in all the colours of the series, matt and "lappata" surface
 Disponible dans toutes les couleurs de la série, surface naturelle et "lappata" Verfügbar in allen Farben, matte und "lappata" Oberfläche

Complementi in acciaio e alluminio a pagina: Technical features on page: Caractéristiques techniques à la page: Technische eigenschaften auf Seite: **509**

meteor

PIETRE NATIVE

decoro meteor brown A e B,
meteor brown cm 30x60 - 11³/₄"x23⁵/₈"

mineral chrom grey

mineral chrom

PIETRE NATIVE



mineral grey cm 30x60 - 11³/₄"x23⁵/₈", cm 30x30 - 11³/₄"x11³/₄"

COLORI COLOURS COULEURS FARBEN

mineral black

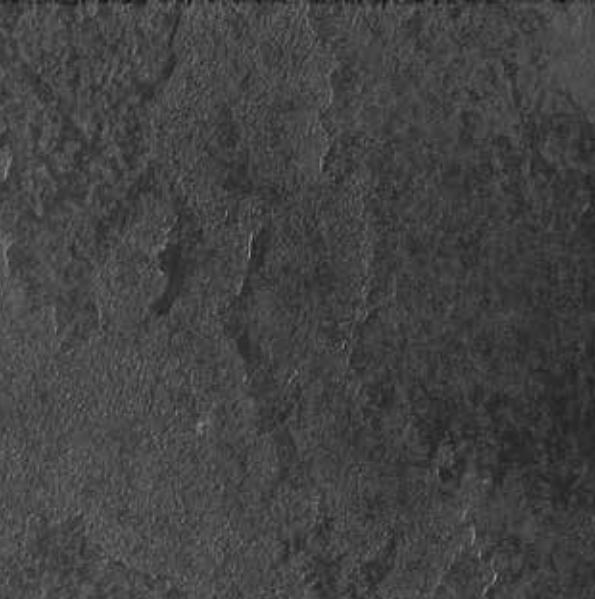

mineral grey



mineral white



mineral brown



mineral gold











mineral beige

mineral chrom



PIETRE NATIVE

mineral beige cm 30x60 - 11³/₄"x23⁵/₈"

FORMATI SIZES FORMATS FORMATE

Formati Sizes Formats Formate	 cm 15x15* 5 ⁷ / ₈ "x5 ⁷ / ₈ "	 cm 15x30* 5 ⁷ / ₈ " x11 ³ / ₄ "	 cm 30x30 11 ³ / ₄ "x11 ³ / ₄ "	 cm 30x60 11 ³ / ₄ "x23 ⁵ / ₈ "
Superfici Surfaces Surfaces Oberflächen				
	mm 8	mm 8	mm 9	mm 9

 Stonizzazione accentuata
 Shade variation accentuated
 Variations d'ombre forte
 Farbtonvarianten Akzentuiert

 **Soft R10**
 **Naturale Matt Naturelle Matt R11**

* Non rettificato Unrectified Non rectifié Nicht kalibriert

Rettificate in un unico calibro Rectified version in a single caliber Rectifiés en un unique calibre Boden Sie in einem einzigen Kaliber

Nel caso di combinazioni di formati di spessori diversi, specificarlo espressamente nell'ordine Please specify in your order if you wish to purchase formats including more than one thickness
 Prière de spécifier dans votre commande si vous souhaitez acheter des formats avec différentes épaisseurs Bitte weisen Sie im Bestellungsformular ausdrücklich darauf hin, wenn Sie Formatkombinationen mit verschiedenen Stärken wünschen

Caratteristiche tecniche e imballi a pagina: Technical features and packing on page: Caractéristiques techniques et emballages à la page: Technische Eigenschaften und Verpackungen auf Seite: **498**

DECORI DECORS DÉCORS DEKORE

mosaico 3x3*



cm 30x30 - 11³/₄"x11³/₄"
 tessera **cm 3x3** - 1¹/₈"x1¹/₈"
 su rete on net sur trame auf Netz

mosaico 6x6*



cm 30x30 - 11³/₄"x11³/₄"
 tessera **cm 6x6** - 2³/₈"x2³/₈"
 su rete on net sur trame auf Netz

composizione A**



cm 30x60 - 11³/₄"x23⁵/₈"
 su rete on net sur trame auf Netz

* Disponibile in tutti i colori della serie, superficie naturale e "soft" Available in all the colours of the series, matt and "soft" surface
 Disponible dans toutes les couleurs de la série, surface naturelle et "soft" Verfügbar in allen Farben, matte und "soft" Oberfläche

** Disponibile in tutti i colori della serie su superficie "soft" Available in all the "soft" colours
 Disponible dans toutes les couleurs pour la surface "soft" Verfügbar in allen Farben der Serie, "soft" Oberfläche

Complementi in acciaio e alluminio a pagina: Technical features on page: Caractéristiques techniques à la page: Technische eigenschaften auf Seite: **509**

PEZZI SPECIALI TRIMS
ACCESSOIRES FORMSTÜCKE

mineral chrom

PIETRE NATIVE

Battiscopa
Bullnose
Plinthe à bord arrondi
Stehsockel
cm 9x30 - 3 1/2"x11 3/4"

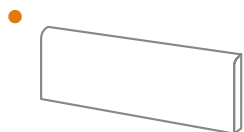

Terminale gradino B.C.
cm 9x30 - 3 1/2"x11 3/4"

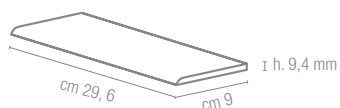

Art. 9900
Angolo terminale
gradino B.C.
cm 9x9 - 3 1/2"x3 1/2"



Gradino Step tread
Nez de marche Stufenplatte
cm 30x30 - 11 3/4"x11 3/4"
cm 30x60 - 11 3/4"x23 5/8"

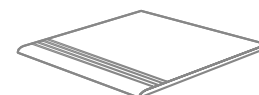

Gradone (pressato)**
cm 30x33 - 11 3/4"x13"

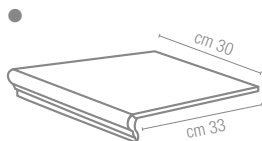

Angolare (pressato)**
cm 33x33 - 13"x13"

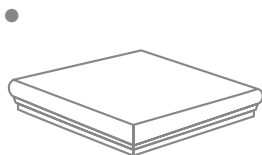

Gradone (assemblato)
cm 30x33 - 11 3/4"x13"

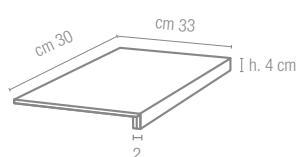

Angolare (assemblato)
cm 30x33 - 11 3/4"x13"

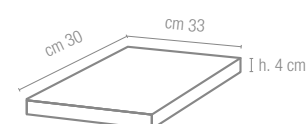

Tozzetto Insert
Cabochon Einleger
cm 9x9 - 3 1/2"x3 1/2"

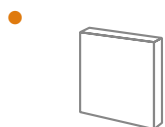

Listello Listel
Listel Zeierleiste
cm 9x30 - 3 1/2"x11 3/4"



Gradino B.C. Step tread B.C.
Nez de marche B.C. Stufenplatte B.C.
cm 30x30 - 11 3/4"x11 3/4"

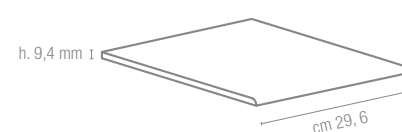

Art. 9830
cm 30 - 11 3/4"

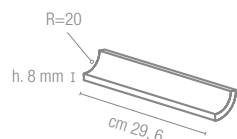

Art. 9833
cm 2x2 - 3/4"x3/4"



Art. 9834
cm 5x5x2 - 17/8"x 17/8"x3/4"

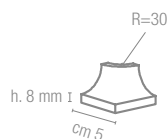

Gradino B.C. Step tread B.C.
Nez de marche B.C. Stufenplatte B.C.
cm 30x60 - 11 3/4"x23 5/8"

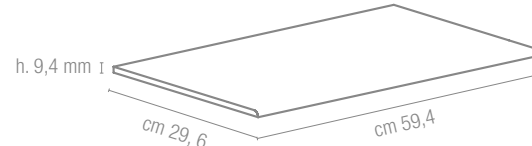

Art. 9835
cm 30 - 11 3/4"

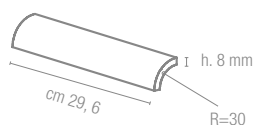

Art. 9837
cm 3x3 - 1 1/8"x 1 1/8"



Art. 9838
cm 5x3x2 - 17/8"x 1 1/8"x 3/4"

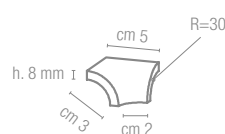

Terminale Pezzo unico pressato
Pièce unique pressée
Pressed single piece
Gepresstes Einzelsück
cm 15x30x3,5
5 7/8"x11 3/4"x1 3/8"

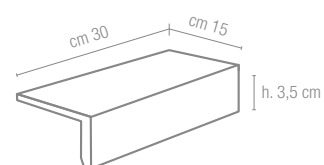

Art. 9660 Pool Wave
cm 60x25 - 23 5/8"x9 7/8"

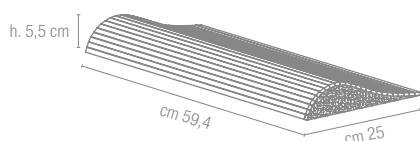

Art. 9667 Pool Wave
cm 30x30 - 11 3/4"x11 3/4"

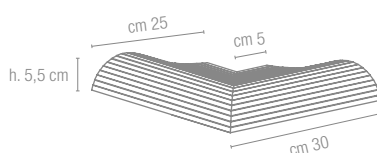

Art. 9668 Pool Wave
cm 30x30 - 11 3/4"x11 3/4"

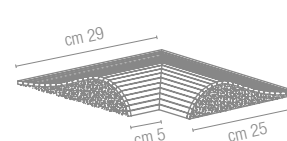

pietra baugé grigia

pietra baugé

PIETRE NATIVE



baugé grigia cm 60x60 - 23⁵/₈"x23⁵/₈"

COLORI COLOURS COULEURS FARBEN

baugé antracite



baugé grigia

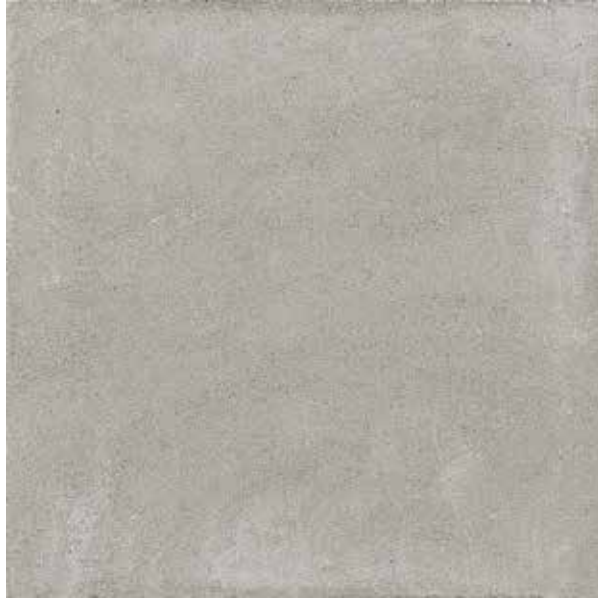

baugé beige

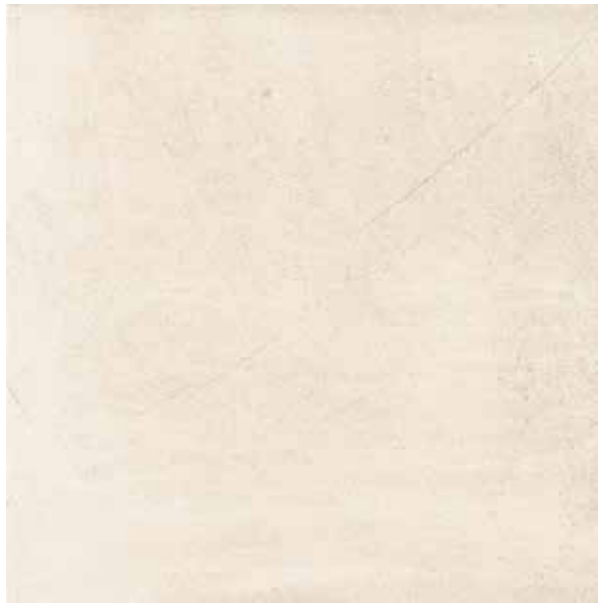

baugé bianca





pietra baugé

PIETRE NATIVE



mosaico baugé antracite 10x10 cm 30x30 - 11³/₄"x11³/₄",
esagono baugé antracite cm 30x51,9 - 11³/₄"x20³/₈"

FORMATI SIZES FORMATS FORMATE

Formati Sizes Formats Formate	 cm 30x60 11 ³ / ₄ "x23 ⁵ / ₈ "	 cm 60x60 23 ⁵ / ₈ "x23 ⁵ / ₈ "	 cm 60x60 23 ⁵ / ₈ "x23 ⁵ / ₈ "
Superfici Surfaces Surfaces Oberflächen	●	●	●
	mm 10 mm 9 mm 9**	mm 10	mm 20*



Stonizzazione accentuata
Shade variation accentuated
Variations d'ombre forte
Farbtonvarianten Akzentuiert

● Naturale Matt Naturelle Matt **R10 A+B**
* **R 11 A+B+C**

** Non rettificato Unrectified Non rectifié Nicht kalibriert

Rettificate in un unico calibro Rectified version in a single caliber Rectifiés en un unique calibre Boden Sie in einem einzigen Kaliber

Caratteristiche tecniche e imballi a pagina: Technical features and packing on page: Caractéristiques techniques et emballages à la page: Technische Eigenschaften und Verpackungen auf Seite: **498**

PEZZI SPECIALI TRIMS ACCESSOIRES FORMSTÜCKE

▲ 2pcs  45°

Battiscopa Bullnose
Plinthe à bord arrondi
Stehsockel
cm 9x60 - 3¹/₂"x23⁵/₈"



Gradino Step tread
Nez de marche
Stufenplatte
cm 30x60 - 11³/₄"x23⁵/₈"

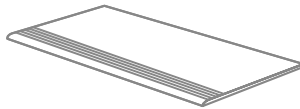

Terminale Pezzo incollato
Glued piece Pièce collée
Geklebter Stück
cm 15x30x5 - 5⁷/₈"x11³/₄"x2"

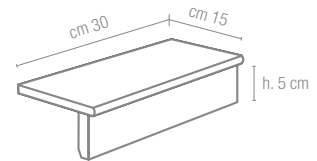

Gradone (assemblato)
cm 60x33 - 23⁵/₈"x13"

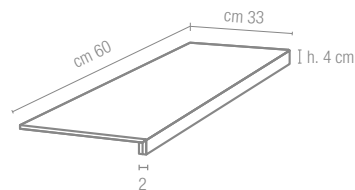

Angolare (assemblato)
cm 60x33 - 23⁵/₈"x47¹/₄"

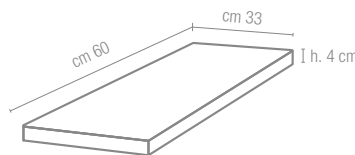

Art. 9640 Bordo
cm 30x60 - 11³/₄"x23⁵/₈"

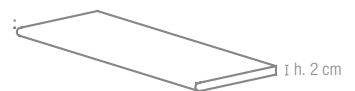

Art. 9642 Bordo angolare esterno ▲
cm 30x60 - 11³/₄"x23⁵/₈"



Art. 9641 Bordo angolare interno ▲
cm 30x60 - 11³/₄"x23⁵/₈"

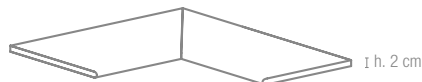

DECORI DECORS DÉCORS DEKORE

pietra baugé

PIETRE NATIVE

mosaico 6x6*



cm 30x30 - 11³/₄"x11³/₄"
 tessera **cm 6x6 - 2³/₈"x2³/₈"**
su rete on net sur trame auf Netz

mosaico 10x10*



cm 30x30 - 11³/₄"x11³/₄"
 tessera **cm 10x10 - 4"x4"**
su rete on net sur trame auf Netz

esagono*



cm 30x51,9 - 11³/₄"x20³/₈"

* Disponibile in tutti i colori della serie Available in all the colours of the series Disponible dans tous les couleurs de la série Verfügbar in allen farben



baugé bianca cm 60x60 - 23⁵/₈"x23⁵/₈",
mosaico baugé bianca 10x10 cm 30x30 - 11³/₄"x11³/₄"

pietre di sardegna cala luna

pietre di sardegna

PIETRE NATIVE

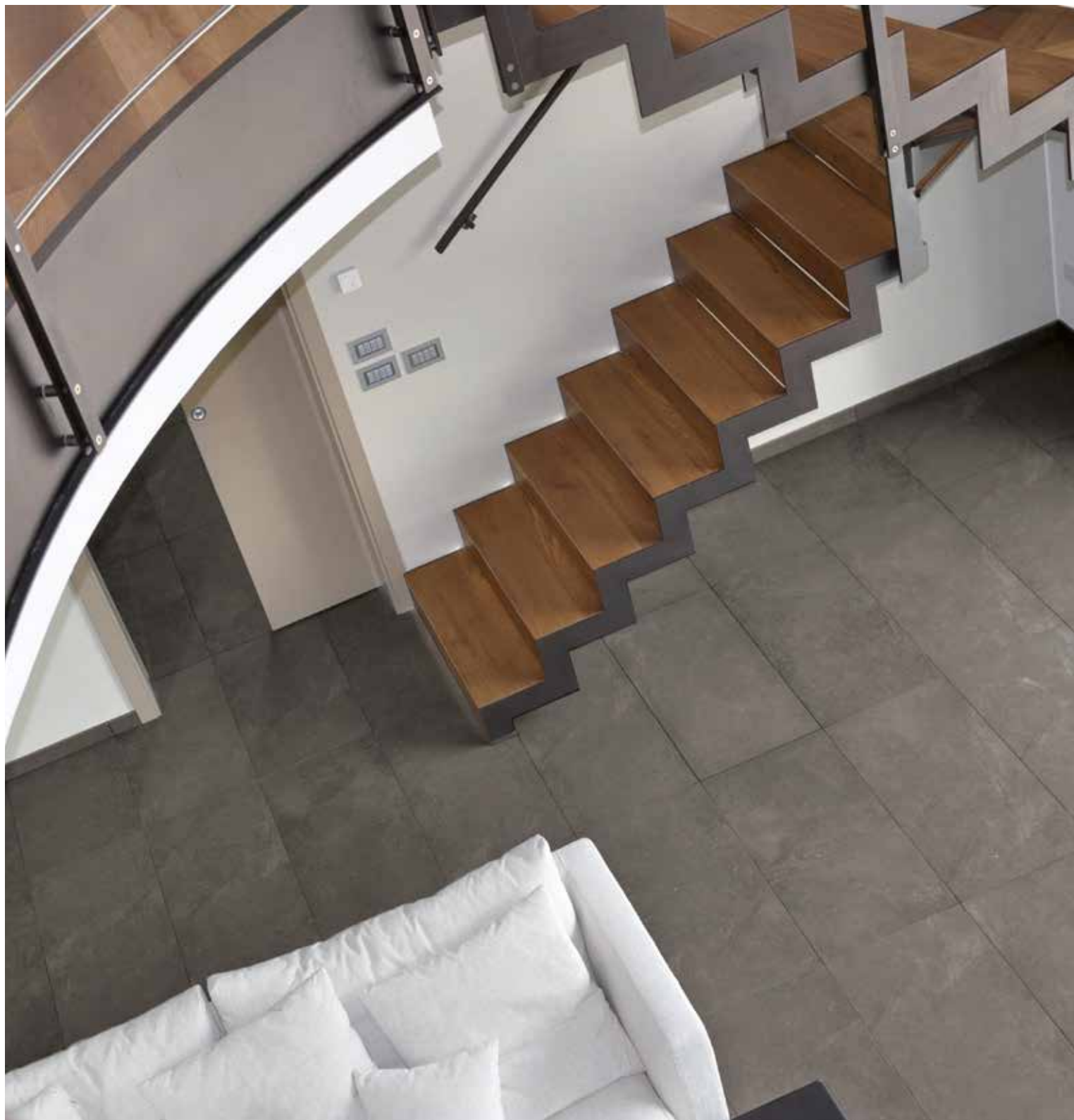

cala luna cm 45x90 - 17³/₄"x35³/₈"

COLORI COLOURS COULEURS FARBEN

tavolara



caprera



punta molarà



pevero



cala luna



stintino

pietre di sardegna

PIETRE NATIVE

porto rotondo













porto cervo

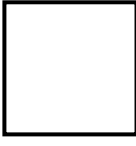

cala luna cm 90x90 - 35³/₈"x35³/₈"

FORMATI SIZES FORMATS FORMATE

									
Formati Sizes Formats Formate	cm 15x15 5 ⁷ / ₈ "x5 ⁷ / ₈ "	cm 30x30 11 ³ / ₄ "x11 ³ / ₄ "	cm 45x45 17 ³ / ₄ "x17 ³ / ₄ "	cm 15x60 5 ⁷ / ₈ "x23 ⁵ / ₈ "	cm 30x60 11 ³ / ₄ "x23 ⁵ / ₈ "	cm 60x60 23 ⁵ / ₈ "x23 ⁵ / ₈ "	cm 45x90 17 ³ / ₄ "x35 ³ / ₈ "	cm 90x90 35 ³ / ₈ "x35 ³ / ₈ "	cm 90x90 35 ³ / ₈ "x35 ³ / ₈ "
Tavolara	● ●	● ●	● ●	● ●	● ●	● ●	● ●	● ●	●
Caprera	● ●	● ●	● ●	● ●	● ●	● ●	● ●	● ●	●
Punta Molara	● ●	● ●	● ●	● ●	● ●	● ●	● ●	● ●	●
Porto Rotondo	● ●	● ●	● ●	● ●	● ●	● ●	● ●	● ●	●
Pevero	● ●	● ●	● ●	● ●	● ●	● ●	● ●	● ●	
Cala Luna	● ●	● ●	● ●	● ●	● ●	● ●	● ●	● ●	●
Stintino	● ●	● ●	● ●	● ●	● ●	● ●	● ●	● ●	
Porto Cervo	● ●	● ●	● ●	● ●	● ●	● ●	● ●	● ●	●
 mm 9	mm 9	mm 9	mm 9	mm 9	mm 10	mm 10	mm 10	mm 10	mm 20
 mm 4,9			mm 4,9		mm 9	mm 4,9	mm 4,9		



Stonizzazione accentuata
Shade variation accentuated
Variations d'ombre forte
Farbtonvarianten Akzentuiert

● Naturale Matt Naturelle Matt **R10**
● Lappata
● Grip **R11 A+B**

Rettificate in un unico calibro Rectified version in a single caliber Rectifiés en un unique calibre Boden Sie in einem einzigen Kaliber

Nel caso di combinazioni di formati di spessori diversi, specificarlo espressamente nell'ordine Please specify in your order if you wish to purchase formats including more than one thickness
Prière de spécifier dans votre commande si vous souhaitez acheter des formats avec différentes épaisseurs Bitte weisen Sie im Bestellungsformular ausdrücklich darauf hin, wenn Sie
Formatkombinationen mit verschiedenen Stärken wünschen

Caratteristiche tecniche e imballi a pagina: Technical features and packing on page: Caractéristiques techniques et emballages à la page: Technische Eigenschaften und Verpackungen auf Seite: **498**

tavolara, porto rotondo cm 30x60 - 11³/₄"x23⁵/₈"
composizione A porto rotondo cm 30x60 - 11³/₄"x23⁵/₈"
deco E porto rotondo cm 30x30 - 11³/₄"x11³/₄"



 Lastre Kontinua
 Kontinua Slabs
 Dalles Kontinua
 Kontinua Platten



cm 60x120
23⁵/₈"x47¹/₄"

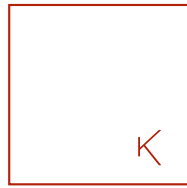

cm 60x120
23⁵/₈"x47¹/₄"



cm 120x120
47¹/₄"x47¹/₄"

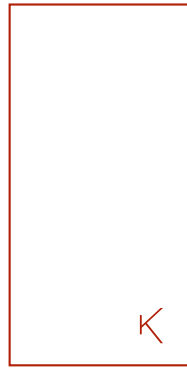

cm 120x240
47¹/₄"x94¹/₂"

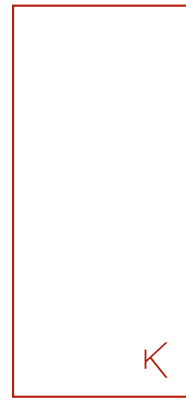

cm 120x260
47¹/₄"x102³/₈"

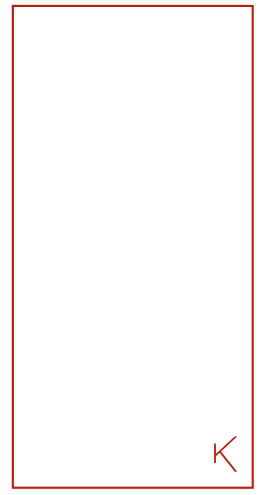

cm 160x320
63"x126"

● ●	●	●	●	●	
● ●	●	●	●	●	●
● ●	●	●	●	●	
● ●	●	●	●	●	●
● ●					
● ●	●	●	●	●	
● ●					
● ●	●	●	●	●	

mm 10
mm 4,9

mm 6,5

mm 10
mm 6,5

mm 6,5

mm 6,5

mm 12

PEZZI SPECIALI TRIMS ACCESSOIRES FORMSTÜCKE

Battiscopa Bullnose
Plinthe à bord arrondi
Stehsockel
cm 9x30 - 3¹/₂"x11³/₄"
cm 9x45 - 3¹/₂"x17³/₄"
cm 9x60 - 3¹/₂"x23⁵/₈"
cm 9x90 - 3¹/₂"x35³/₈"

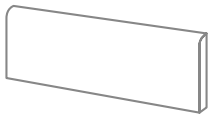

Gradino Step tread
Nez de marche
Stufenplatte
cm 30x30 - 11³/₄"x11³/₄"
cm 45x45 - 17³/₄"x17³/₄"
cm 30x60 - 11³/₄"x23⁵/₈"

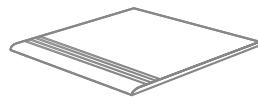

Listello Listel
Listel Zeierleiste
cm 9x30 - 3¹/₂"x11³/₄"
cm 9x45 - 3¹/₂"x17³/₄"



Terminale Pezzo incollato
Glued piece Pièce collée
Gelebter Stück
cm 15x30x5 - 5⁷/₈"x11³/₄"x2"

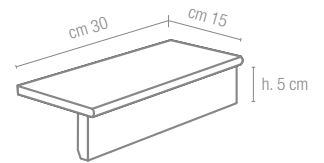

Gradone (pressato)*
cm 30x33 - 11³/₄"x13"

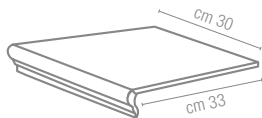

Angolare (pressato)*
cm 30x33 - 11³/₄"x13"

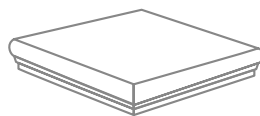

Tozzetto Insert
Cabocho
Einleger
cm 9x9 - 3¹/₂"x3¹/₂"

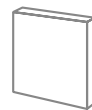

Scalino e scalino angolare
cm 30x33 - 11³/₄"x13"

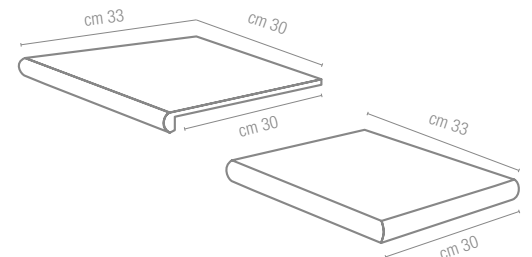

* Solo nei colori: Only the colours: Seulement les couleurs: Nur farben:
Porto Cervo, Porto Rotondo, Cala Luna, Stintino, Pevero, Caprera

SUPERFICI SURFACES SURFACES OBERFLÄCHEN

lappata

naturale matt
naturelle matt
R10 A

DECORI DECORS
DÉCORS DEKORE

pietre di sardegna

PIETRE NATIVE

mosaico 3x3*

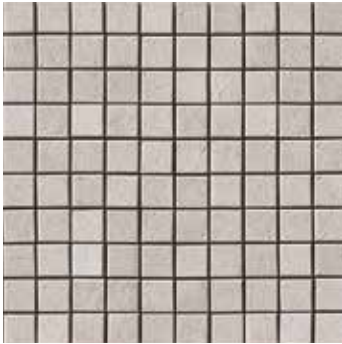

cm 30x30 - 11³/₄"x11³/₄"
tessera **cm 3x3** - 1¹/₈"x1¹/₈"
su rete on net sur trame auf Netz

mosaico 6x6*



cm 30x30 - 11³/₄"x11³/₄"
tessera **cm 6x6** - 2³/₈"x2³/₈"
su rete on net sur trame auf Netz

▼
▲ mm 10 KONTINUA mm 6,5

decoro E*



cm 30x30 - 11³/₄"x11³/₄"
listello **cm 1,5x15** - 1/2"x5⁷/₈"

composizione A**



cm 30x60 - 11³/₄"x23⁵/₈"
su rete on net sur trame auf Netz

fascia sardegna A



cm 5x30 - 2"x11³/₄"
punta molara, tavolara,
lavagna bianca

fascia sardegna B



cm 5x30 - 2"x11³/₄"
cala luna, porto cervo,
porto rotondo

* Disponibile in tutti i colori della serie, superficie naturale e lappata Available in all the colours of the series, matt and "lappata" surface
Disponibile dans toutes les couleurs de la série, surface naturelle et "lappata" Verfügbar in allen Farben, matte und "lappata" Oberfläche

Complementi in acciaio e alluminio a pagina: Technical features on page: Caractéristiques techniques à la page: Technische eigenschaften auf Seite: **509**

DECORI DECORS DÉCORS DEKORE

diagonal



cm 120x240 47¹/₄"x 94¹/₂"

 Kontinua mm 6,5

Decoro abbinabile con
le collezioni Pietre di Paragone,
Pietre di Sardegna e Marmoker
Decor matching the Pietre di
Paragone, Pietre di Sardegna
and Marmoker collections
Décor pouvant être associé aux
collections Pietre di Paragone,
Pietre di Sardegna et Marmoker
Dekor kombinierbar mit den
Kollektionen Pietre di Paragone,
Pietre di Sardegna und Marmoker



round square cm 120x240 - 47¹/₄"x94¹/₂"

pietre di sardegna

PIETRE NATIVE

optical



cm 120x240 47¹/₄"x 94¹/₂"

 Kontinua mm 6,5



Decoro abbinabile con
le collezioni Pietre di Paragone,
Pietre di Sardegna e Marmoker
Decor matching the Pietre di
Paragone, Pietre di Sardegna
and Marmoker collections
Décor pouvant être associé aux
collections Pietre di Paragone,
Pietre di Sardegna et Marmoker
Dekor kombinierbar mit den
Kollektionen Pietre di Paragone,
Pietre di Sardegna und Marmoker



optical cm 120x240 - 47¹/₄"x94¹/₂"

DECORI DECORS DÉCORS DEKORE

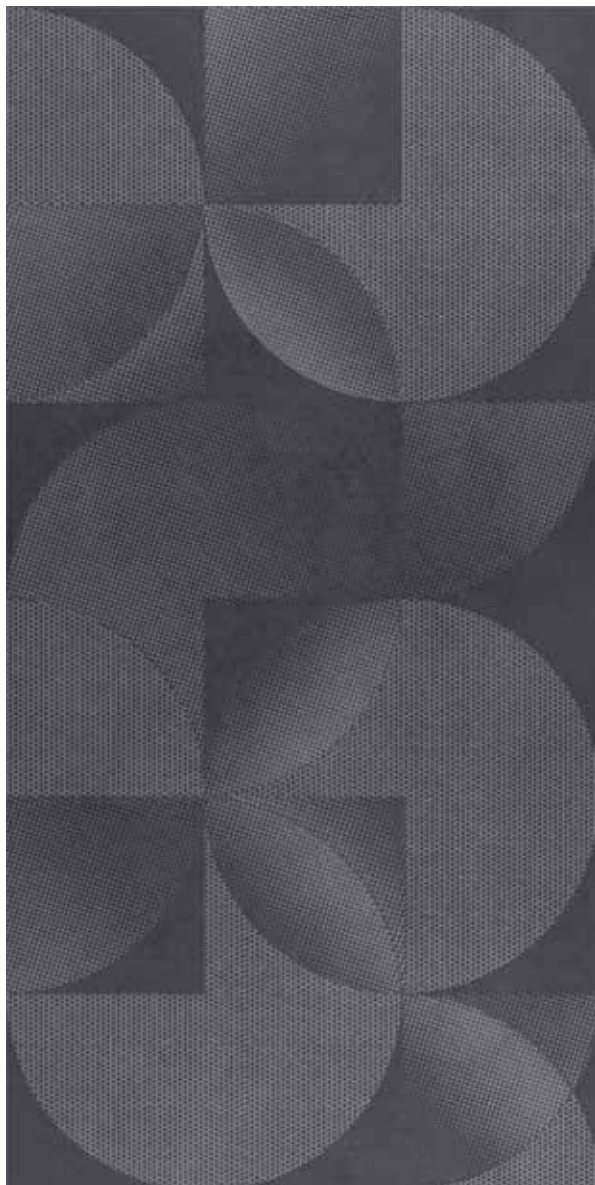
round square

cm 120x240 47¹/₄"x 94¹/₂"

 Kontinua mm 6,5

Decoro abbinabile con
 le collezioni Pietre di Paragone,
 Pietre di Sardegna e Marmoker
 Decor matching the Pietre di
 Paragone, Pietre di Sardegna
 and Marmoker collections
 Décor pouvant être associé aux
 collections Pietre di Paragone,
 Pietre di Sardegna et Marmoker
 Dekor kombinierbar mit den
 Kollektionen Pietre di Paragone,
 Pietre di Sardegna und Marmoker

diagonal cm 120x240 - 47¹/₄"x94¹/₂"

pietre di sardegna

PIETRE NATIVE

golden paint

cm 120x240 47¹/₄"x 94¹/₂"

 Kontinua mm 6,5

Decoro abbinabile con
le collezioni Pietre di Paragone,
Pietre di Sardegna e Marmoker
Decor matching the Pietre di
Paragone, Pietre di Sardegna
and Marmoker collections
Décor pouvant être associé aux
collections Pietre di Paragone,
Pietre di Sardegna et Marmoker
Dekor kombinierbar mit den
Kollektionen Pietre di Paragone,
Pietre di Sardegna und Marmoker

golden paint cm 120x240 - 47¹/₄"x94¹/₂"

stonewash wash brown

stonewash

GRANITOKER



wash brown cm 30x180 - 11³/₄"x70⁷/₈"

COLORI COLOURS COULEURS FARBEN

wash brown



wash grey



wash cream







stonewash





GRANITOKER



wash grey cm 22,5x180 - 8⁷/₈"x70⁷/₈", listone wash grey cm 22,5x180 - 8⁷/₈"x70⁷/₈"

FORMATI SIZES FORMATS FORMATE

					
Formati Sizes Formats Formate	cm 60x60 23 ⁵ / ₈ "x23 ⁵ / ₈ "	cm 90x90 35 ³ / ₈ "x35 ³ / ₈ "	cm 20x120 12"x47 ¹ / ₈ "	cm 30x120 11 ³ / ₄ "x47 ¹ / ₈ "	cm 60x120 23 ⁵ / ₈ "x47 ¹ / ₄ "
Superfici Surfaces Surfaces Oberflächen	●	●	●	●	●
	mm 10	mm 10	mm 10	mm 10	mm 10

				
Formati Sizes Formats Formate	cm 22,5x180 8 ⁷ / ₈ "x70 ⁷ / ₈ "	cm 30x180 11 ³ / ₄ "x70 ⁷ / ₈ "	cm 45x180 17 ³ / ₄ "x70 ⁷ / ₈ "	cm 90x180 35 ³ / ₈ "x70 ⁷ / ₈ "
Superfici Surfaces Surfaces Oberflächen	●	●	●	●
	mm 10	mm 10	mm 10	mm 10



● Naturale Matt Naturelle Matt R9

Rettificata in un unico calibro Rectified version in a single caliber Rectifiés en un unique calibre Boden Sie in einem einzigen Kaliber

Caratteristiche tecniche e imballi a pagina: Technical features and packing on page: Caractéristiques techniques et emballages à la page: Technische Eigenschaften und Verpackungen auf Seite: **501**

PEZZI SPECIALI TRIMS ACCESSOIRES FORMSTÜCKE

Battiscopa Bullnose
Plinthe à bord arrondi
Stehsockel
cm 9x90 - 3¹/₂"x35³/₈"
cm 9x60 - 3¹/₂"x23⁵/₈"



Gradino Step tread
Nez de marche
Stufenplatte
cm 30x90 - 11³/₄"x35³/₈"
cm 30x60 - 11³/₄"x23⁵/₈"

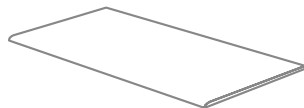

Gradone (assemblato)
cm 90x33 - 35³/₈"x13"
cm 120x33 - 47¹/₄"x13"

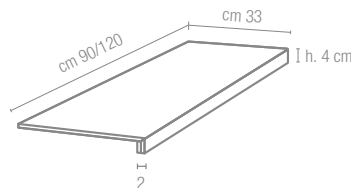

Angolare (assemblato)
cm 90x33 - 35³/₈"x13"
cm 120x33 - 47¹/₄"x13"

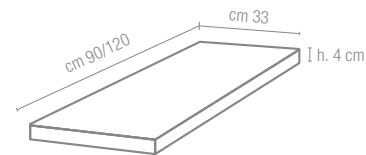

DECORI DECORS DÉCORS DEKORE

stonewash

GRANITOKER

mosaico 6x6*



cm 30x30 - 11³/₄"x11³/₄"
 tessera **cm 6x6** - 2³/₈"x2³/₈"
 su rete on net sur trame auf Netz

composizione D*



cm 28,5x57,6 - 11¹/₄"x22⁵/₈"
 mattoncino **cm 7x28** - 2³/₄"x11¹/₄"
 su rete on net sur trame auf Netz

listone wash*



cm 22,5x180 - 8⁷/₈"x70⁷/₈"
cm 22,5x120 - 8⁷/₈"x 47¹/₄"

* Disponibile in tutti i colori della serie Available in all the colours of the series Disponible dans tous les couleurs de la série Verfügbar in allen farben

terre toscane san casciano

terre toscane

PIETRE NATIVE



san casciano cm 30x60 - 11³/₄"x23⁵/₈"

COLORI COLOURS COULEURS FARBEN

montepulciano



gaiole



greve



volpaia



san gimignano



verrazzano

terre toscane

PIETRE NATIVE

san casciano









monteriggioni



verrazzano

cm 30x60 - 11³/₄"x23⁵/₈"

FORMATI SIZES FORMATS FORMATE

						
Formati Sizes Formats Formate	cm 30x30 11 ³ / ₄ "x11 ³ / ₄ "	cm 30x60 11 ³ / ₄ "x23 ⁵ / ₈ "	cm 60x60 23 ⁵ / ₈ "x23 ⁵ / ₈ "	cm 45x90 17 ³ / ₄ "x35 ³ / ₈ "	cm 60x120 23 ⁵ / ₈ "x47 ¹ / ₄ "	cm 120x120 47 ¹ / ₄ "x47 ¹ / ₄ "
Superfici Surfaces Surfaces Oberflächen	● ●	● ●	● ●	● ●	● ●	● ●
	mm 9	mm 10 mm 9	mm 10	mm 10	mm 10	mm 10



Stonizzazione media
Shade variation medium
Variations d'ombre moyenne
Farbtonvarianten Mittel

● Naturale Matt Naturelle Matt R9
● Lappata

Rettificata in un unico calibro Rectified version in a single caliber Rectifiés en un unique calibre Boden Sie in einem einzigen Kaliber

Nel caso di combinazioni di formati di spessori diversi, specificarlo espressamente nell'ordine

Please specify in your order if you wish to purchase formats including more than one thickness

Prrière de spécifier dans votre commande si vous souhaitez acheter des formats avec différentes épaisseurs

Bitte weisen Sie im Bestellungsformular ausdrücklich darauf hin, wenn Sie Formatkombinationen mit verschiedenen Stärken wünschen

Caratteristiche tecniche e imballi a pagina: Technical features and packing on page: Caractéristiques techniques et emballages à la page: Technische Eigenschaften und Verpackungen auf Seite: **498**

PEZZI SPECIALI TRIMS ACCESSOIRES FORMSTÜCKE

Battiscopa Bullnose
Plinthe à bord arrondi
Stehsockel
cm 9x30 - 3¹/₂"x11³/₄"
cm 9x60 - 3¹/₂"x23⁵/₈"
cm 9x90 - 3¹/₂"x35³/₈"

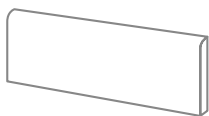

Gradino Step tread
Nez de marche Stufenplatte
cm 30x30 - 11³/₄"x11³/₄"
cm 30x60 - 11³/₄"x23⁵/₈"

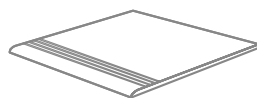

Terminale Pezzo incollato
Glued piece Pièce collée
Geklebter Stück
cm 15x30x5 - 5⁷/₈"x11³/₄"x2"

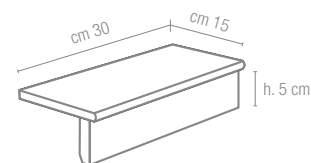

Tozzetto
Insert
Cabochoon
Einleger
cm 9x9 - 3¹/₂"x3¹/₂"

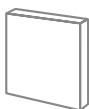

Listello
Listel
Listel
Zeilerleiste
cm 9x30 - 3¹/₂"x11³/₄"



Scalino
e scalino angolare
cm 30x33 - 11³/₄"x13"

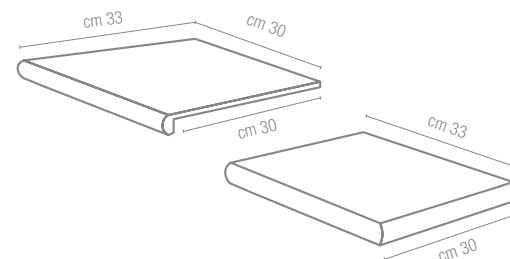

SUPERFICI SURFACES
SURFACES OBERFLÄCHEN

terre toscane

PIETRE NATIVE

lappata

**naturale matt
naturelle matt
R9**

DECORI DECORS DÉCORS DEKORE

mosaico terre toscane A

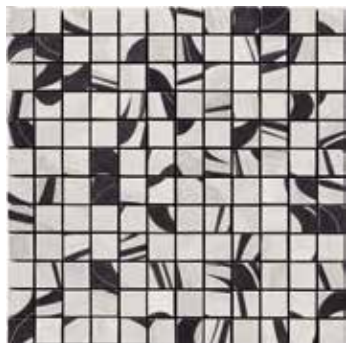

cm 30x30 - 11³/₄"x11³/₄"
 tessera **cm 2,2x2,2** - 7/8"x7/8"
 su rete on net sur trame auf Netz
san casciano
 naturale matt naturelle Matt

mosaico terre toscane B



cm 30x30 - 11³/₄"x11³/₄"
 tessera **cm 2,2x2,2** - 7/8"x7/8"
 su rete on net sur trame auf Netz
verrazzano
 naturale matt naturelle Matt

composizione A*



cm 30x60 - 11³/₄"x23⁵/₈"
 su rete on net sur trame auf Netz

mosaico 3x3*



cm 30x30 - 11³/₄"x11³/₄"
 tessera **cm 3x3** - 1¹/₈"x1¹/₈"
 su rete on net sur trame auf Netz

chiusura A*



cm 4x60
 1⁵/₈"x23⁵/₈"

decoro*



cm 30x60
 11³/₄"x23⁵/₈"

chiusura B*



cm 6x60
 2³/₈"x23⁵/₈"

mosaico 6x6*



cm 30x30 - 11³/₄"x11³/₄"
 tessera **cm 6x6** - 2³/₈"x2³/₈"
 su rete on net sur trame auf Netz

* Disponibile in tutti i colori della serie, superficie naturale e lappata
 Available in all the colours of the series, matt and "lappata" surface
 Disponible dans toutes les couleurs de la série, surface naturelle et "lappata"
 Verfügbar in allen Farben, matte und "lappata" Oberfläche

terre toscane

PIETRE NATIVE

mosaico terre toscane A
san casciano cm 30x30 - 11³/₄"x11³/₄",
san casciano, montepulciano
cm 30x60 - 11³/₄"x23⁵/₈"

pietre etrusche

PIETRE NATIVE



tuscania cm 60x120 - 23⁵/₈"x47¹/₄"

COLORI COLOURS COULEURS FARBEN

manciano



sovana



vulci



santa fiora



pitigliano



tuscania

pietre etrusche

PIETRE NATIVE

capalbio





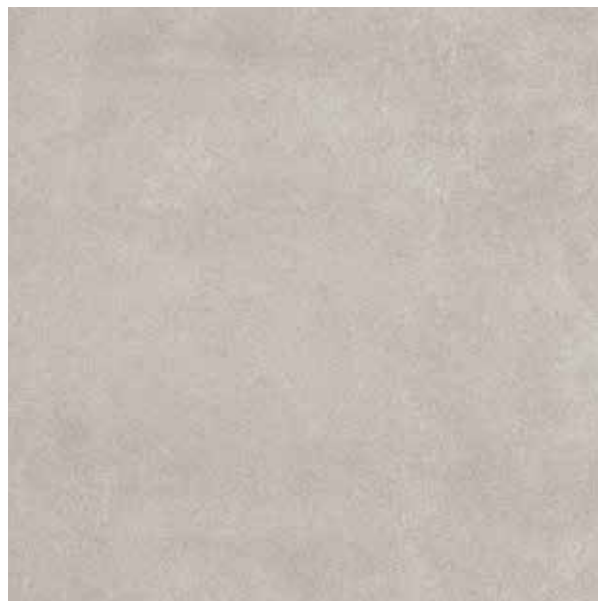





















paestum



saturnia

tarquinia

FORMATI SIZES FORMATS FORMATE

Formati Sizes Formats Formate								
	cm 15x15 5 ⁷ / ₈ "x5 ⁷ / ₈ "	cm 30x30 11 ³ / ₄ "x11 ³ / ₄ "	cm 45x45 17 ³ / ₄ "x17 ³ / ₄ "	cm 15x60 5 ⁷ / ₈ "x23 ⁵ / ₈ "	cm 30x60 11 ³ / ₄ "x23 ⁵ / ₈ "	cm 60x60 23 ⁵ / ₈ "x23 ⁵ / ₈ "	cm 45x90 17 ³ / ₄ "x35 ³ / ₈ "	cm 60x120 23 ⁵ / ₈ "x47 ¹ / ₄ "
Superfici Surfaces Surfaces Oberflächen	 	 	 	 	 	 	 	 
	mm 9	mm 9 mm 8*	mm 9 mm 9* mm 4,9	mm 9	mm 10 mm 9 mm 9*	mm 10 mm 10* mm 4,9	mm 10 mm 4,9	mm 10 mm 4,9



Stonizzazione leggera
Shade variation subtle
Variations d'ombre légère
Farbtonvarianten Leicht

 Naturale Matt Naturelle Matt **R9**
 Lappata

* Solo naturale, versione non rettificata e solo nei colori: Only matt, not rectified version and only in the colours: Seulement naturel, version non rectifiée et seulement dans les couleurs :
Nur matt, in der nicht rektifizierte Version und in die Farben: **Manciano, Sovana, Capalbio, Tuscania, Paestum, Saturnia**

Rettificata in un unico calibro Rectified version in a single caliber Rectifiés en un unique calibre Boden Sie in einem einzigen Kaliber

Nel caso di combinazioni di formati di spessori diversi, specificarlo espressamente nell'ordine

Please specify in your order if you wish to purchase formats including more than one thickness

Prière de spécifier dans votre commande si vous souhaitez acheter des formats avec différentes épaisseurs

Bitte weisen Sie im Bestellungsformular ausdrücklich darauf hin, wenn Sie Formatkombinationen mit verschiedenen Stärken wünschen

Caratteristiche tecniche e imballi a pagina: Technical features and packing on page: Caractéristiques techniques et emballages à la page: Technische Eigenschaften und Verpackungen auf Seite: **498**

PEZZI SPECIALI TRIMS ACCESSOIRES FORMSTÜCKE

Battiscopa Bullnose
Plinthe à bord arrondi
Stehsockel
cm 9x30 - 3¹/₂"x11³/₄"
cm 9x45 - 3¹/₂"x17³/₄"
cm 9x60 - 3¹/₂"x23⁵/₈"

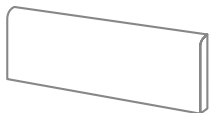

Gradino Step tread
Nez de marche Stufenplatte
cm 30x30 - 11³/₄"x11³/₄"
cm 45x45 - 17³/₄"x17³/₄"
cm 30x60 - 11³/₄"x23⁵/₈"

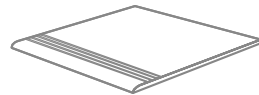

Terminale Pezzo incollato
Glued piece Pièce collée
Geklebter Stück
cm 15x30x5 - 5⁷/₈"x11³/₄"x2"

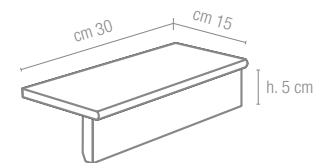

Tozzetto
Insert
Cabochoon
Einleger
cm 9x9 - 3¹/₂"x3¹/₂"

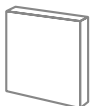

Listello
Listel
Listel
Zeierleiste
cm 9x30 - 3¹/₂"x11³/₄"
cm 9x45 - 3¹/₂"x17³/₄"



Scalino
e scalino angolare
cm 30x33 - 11³/₄"x13"

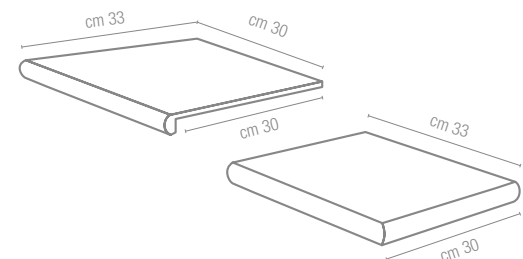

SUPERFICI SURFACES
SURFACES OBERFLÄCHEN

pietre etrusche

PIETRE NATIVE

lappata

**naturale matt
naturelle matt
R9**

DECORI DECORS DÉCORS DEKORE

decoro A*

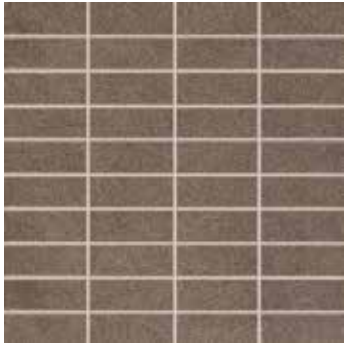

cm 30x30 - 11³/₄"x11³/₄"
tessera cm 2,5x7,5 - 1"x3"

decoro B*



cm 30x30 - 11³/₄"x11³/₄"
tessera cm 7,5x7,5 - 3"x5⁷/₈"

decoro C*



cm 30x60 - 11³/₄"x23⁵/₈"
listello cm 1,5x60 - 1/2"x23⁵/₈"

fascia etrusca A**



cm 5x45 - 2"x17³/₄"

angolo etrusca A**



cm 5x5 - 2"x2"

decoro D*

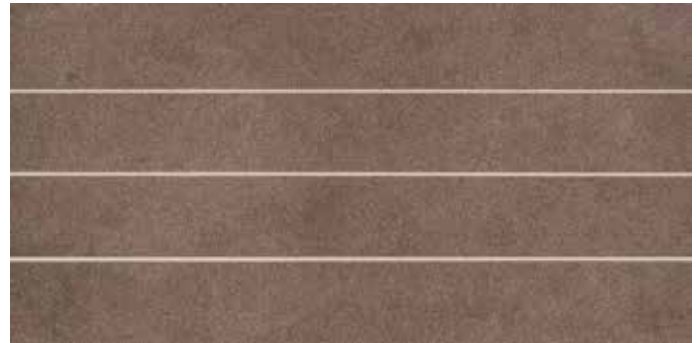

cm 30x60 - 11³/₄"x23⁵/₈"
listello cm 7,5x60 - 3"x23⁵/₈"

* Disponibile in tutti i colori della serie, superficie naturale e lappata Available in all the colours of the series, matt and "lappata" surface
Disponible dans toutes les couleurs de la série, surface naturelle et "lappata" Verfügar in allen Farben, matte und "lappata" Oberfläche

** Disponibile nei colori: Available in the colours: Disponible dans les couleurs : Verfügar in den folgenden Farben:
A (Pitigliano/Saturnia), B (Manciano/Capalbio), C (Tuscania/Santafiora), D (Paestum/Vulci)

Complementi in acciaio e alluminio a pagina: Technical features on page: Caractéristiques techniques à la pag:e Technische eigenschaften auf Seite: 509

pietre etrusche

PIETRE NATIVE

saturnia cm 60x120 - 23⁵/₈"x47¹/₄"

basaltina linosa

basaltina

PIETRE NATIVE



linosa cm 30x60 - 11³/₄"x23⁵/₈"

COLORI COLOURS COULEURS FARBEN

vulcano



linosa



lipari



stromboli



pantelleria



ischia



basaltina

PIETRE NATIVE



ischia cm 45x90 - 17³/₄"x35³/₈"

FORMATI SIZES FORMATS FORMATE

Formati Sizes Formats Formate	cm 30x30 11 ³ / ₄ "x11 ³ / ₄ "	cm 45x45 17 ³ / ₄ "x17 ³ / ₄ "	cm 30x60 11 ³ / ₄ "x23 ⁵ / ₈ "	cm 60x60 23 ⁵ / ₈ "x23 ⁵ / ₈ "	cm 45x90 17 ³ / ₄ "x35 ³ / ₈ "	cm 60x120 23 ⁵ / ₈ "x47 ¹ / ₄ "
Superfici Surfaces Surfaces Oberflächen	● ●	● ●	● ●	● ●	● ●	● ●
 	mm 9	mm 9	mm 10 mm 9	mm 10	mm 10	mm 10
 Stonalizzazione media Shade variation medium Variations d'ombre moyenne Farbtonvarianten Mittel						● Naturale Matt Naturelle Matt R10 A+B ● Lappata

Rettificate in un unico calibro Rectified version in a single caliber Rectifiés en un unique calibre Boden Sie in einem einzigen Kaliber

Specificare espressamente nell'ordine eventuali combinazioni di spessori diversi Specify expressly in the order any combinations of different thicknesses
Préciser expressément dans l'ordre toutes les combinaisons de différentes épaisseurs Geben Sie ausdrücklich in der Reihenfolge an beliebige Kombinationen der verschiedenen Stärken

Caratteristiche tecniche e imballi a pagina: Technical features and packing on page: Caractéristiques techniques et emballages à la page: Technische Eigenschaften und Verpackungen auf Seite: **498**

PEZZI SPECIALI TRIMS ACCESSOIRES FORMSTÜCKE

Battiscopa Bullnose
Plinthe à bord arrondi
Stehsokkel
cm 9x30 - 3¹/₂"x11³/₄"
cm 9x45 - 3¹/₂"x17³/₄"
cm 9x60 - 3¹/₂"x23⁵/₈"

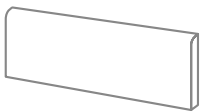

Gradino Step tread
Nez de marche Stufenplatte
cm 30x30 - 11³/₄"x11³/₄"
cm 45x45 - 17³/₄"x17³/₄"
cm 30x60 - 11³/₄"x23⁵/₈"

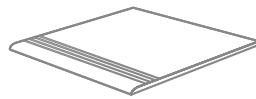

Listello
Listel
Listel
Zeilerleiste
cm 9x30 - 3¹/₂"x11³/₄"
cm 9x45 - 3¹/₂"x17³/₄"



Terminale Pezzo incollato
Glued piece Pièce collée
Geklebter Stück
cm 15x30x5 - 5⁷/₈"x11³/₄"x2"

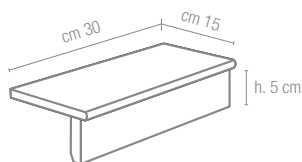

Tozzetto
Insert
Cabochon
Einleger
cm 9x9 - 3¹/₂"x3¹/₂"

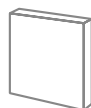

SUPERFICI SURFACES SURFACES OBERFLÄCHEN

basaltina

PIETRE NATIVE

lappata

**naturale matt
naturelle matt
R10 A+B**

DECORI DECORS DÉCORS DEKORE

mosaico 6x6*



cm 30x30 - 11³/₄"x11³/₄"
 tessera **cm 6x6** - 2³/₈"x2³/₈"
su rete on net sur trame auf Netz

mosaico 3x3*



cm 30x30 - 11³/₄"x11³/₄"
 tessera **cm 3x3** - 1¹/₈"x1¹/₈"
su rete on net sur trame auf Netz

inserto A*



cm 30x60 - 11³/₄"x23⁵/₈"

inserto B*



cm 30x60 - 11³/₄"x23⁵/₈"

composizione B*



cm 30x60 - 11³/₄"x23⁵/₈"
su rete on net sur trame auf Netz

* Disponibile in tutti i colori della serie, superficie naturale e lappata Available in all the colours of the series, matt and "lappata" surface
 Disponible dans toutes les couleurs de la série, surface naturelle et "lappata" Verfügbar in allen Farben, matte und "lappata" Oberfläche

basaltina

PIETRE NATIVE



inserto A + B pantelleria cm 30x60 - 11³/₄"x23⁵/₈"

DECORI DECORS DÉCORS DEKORE

decoro A*



cm 30x30 - $11\frac{3}{4}'' \times 11\frac{3}{4}''$
 tessera **cm 2,5x7,5** - $1'' \times 3''$

decoro B*



cm 30x30 - $11\frac{3}{4}'' \times 11\frac{3}{4}''$
 tessera **cm 7,5x15** - $3'' \times 5\frac{7}{8}''$

decoro C*



cm 30x60 - $11\frac{3}{4}'' \times 23\frac{5}{8}''$
 listello **cm 1,5x60** - $\frac{5}{8}'' \times 23\frac{5}{8}''$

decoro D*



cm 30x60 - $11\frac{3}{4}'' \times 23\frac{5}{8}''$
 listello **cm 7,5x60** - $3'' \times 23\frac{5}{8}''$

* Disponibile in tutti i colori della serie, superficie naturale e lappata Available in all the colours of the series, matt and "lappata" surface
 Disponible dans toutes les couleurs de la série, surface naturelle et "lappata" Verfügbar in allen Farben, matte und "lappata" Oberfläche

basaltina

PIETRE NATIVE



deco A, deco B stromboli cm 30x30 - 11³/₄"x11³/₄"
stromboli cm 30x60 - 11³/₄"x23⁵/₈"

pietra blue new blue moon

pietra blue

PIETRE NATIVE



new blue moon cm 30x60 - 11³/₄"x23⁵/₈"

COLORI COLOURS COULEURS FARBEN

new blue moon



new blue brut

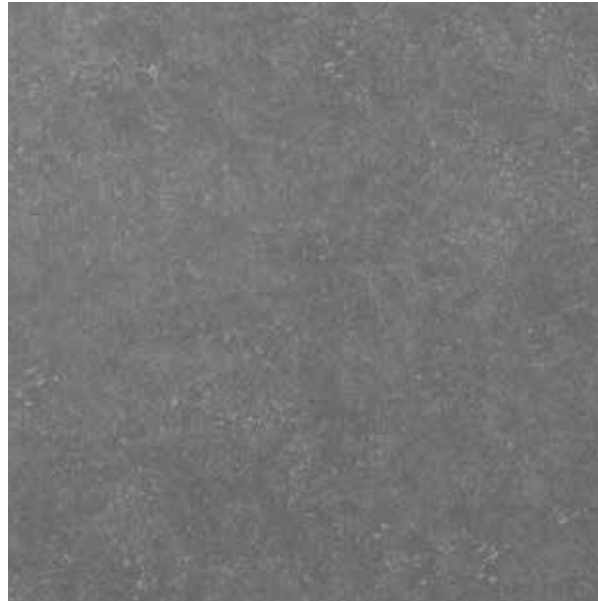

FORMATI SIZES FORMATS FORMATE

Formati Sizes
Formats Formate



cm 30x60
11³/₄"x23⁵/₈"

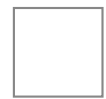

cm 60x60
23⁵/₈"x23⁵/₈"

Superfici Surfaces
Surfaces Oberflächen



mm 10

mm 10



Stonizzazione media
Shade variation medium
Variations d'ombre moyenne
Farbtonvarianten Mittel

● Naturale Matt Naturelle Matt **R9**

Rettificata in un unico calibro Rectified version in a single caliber Rectifiés en un unique calibre Boden Sie in einem einzigen Kaliber

Caratteristiche tecniche e imballi a pagina: Technical features and packing on page: Caractéristiques techniques et emballages à la page: Technische Eigenschaften und Verpackungen auf Seite: **498**

Complementi in acciaio e alluminio a pagina: Technical features on page: Caractéristiques techniques à la page: Technische eigenschaften auf Seite: **509**

PEZZI SPECIALI TRIMS ACCESSOIRES FORMSTÜCKE

Battiscopa
Bullnose
Plinthe à bord arrondi
Stehsokkel
cm 9x60 - 3¹/₂"x23⁵/₈"



Gradino
Step tread
Nez de marche
Stufenplatte
cm 30x60 - 11³/₄"x23⁵/₈"

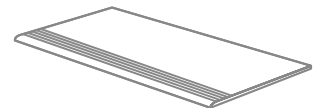

pietra blue

PIETRE NATIVE

new blue moon, cm 30x60 - 11³/₄"x23⁵/₈"

piacentina



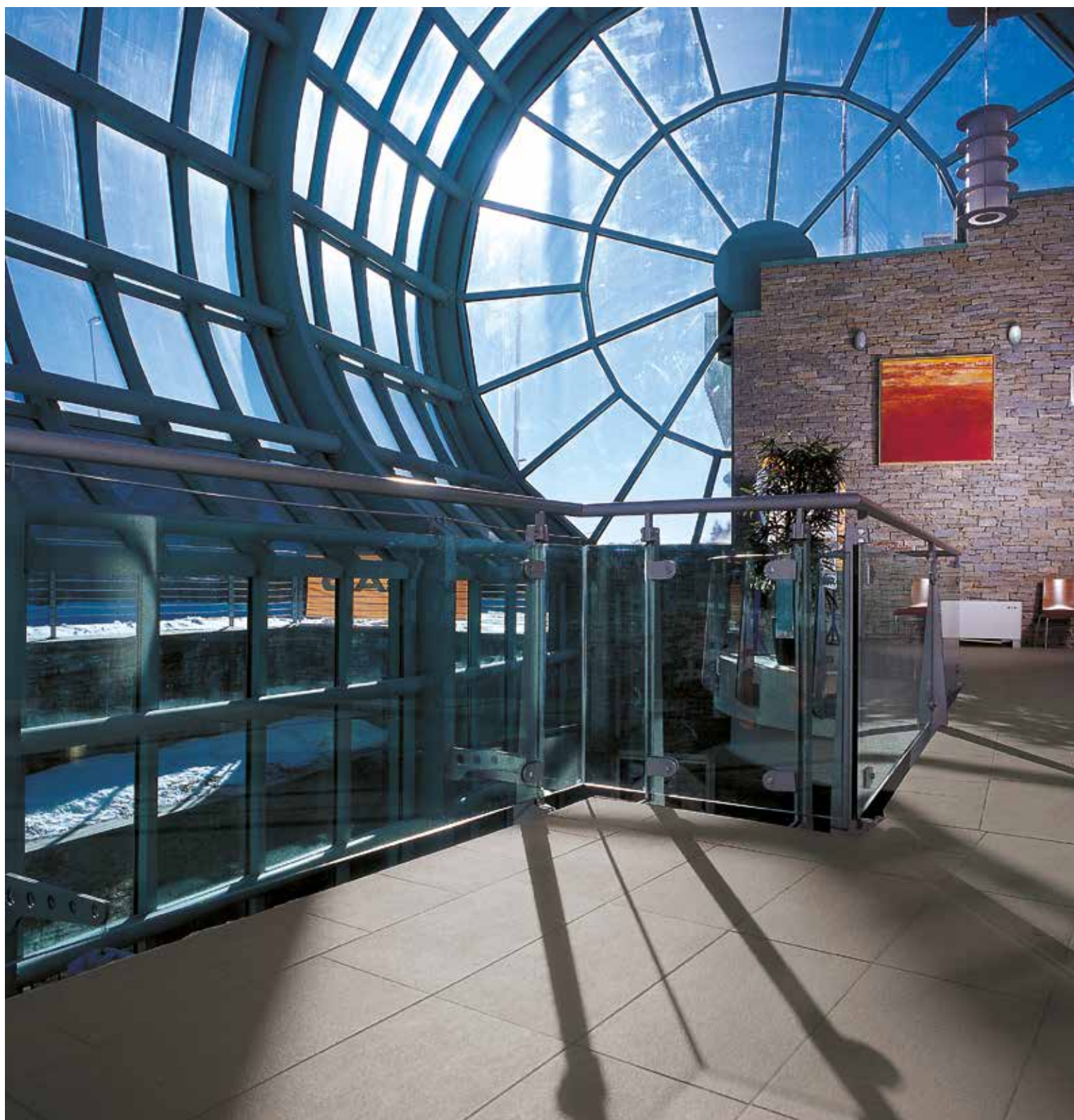

pietra piacentina

PIETRE NATIVE



piacentina cm 30x60 - 11³/₄"x23⁵/₈"

FORMATI SIZES FORMATS FORMATE

Formati Sizes Formats Formate		cm 30x60 11 ³ / ₄ "x 23 ⁵ / ₈ "
Superfici Surfaces Surfaces Oberflächen		
		mm 9
 Stonalizzazione media Shade variation medium Variations d'ombre moyenne Farbtonvarianten Mittel		● Naturale Matt Naturelle Matt R10 A+B

Rettificate in un unico calibro Rectified version in a single caliber Rectifiés en un unique calibre Boden Sie in einem einzigen Kaliber

Caratteristiche tecniche e imballi a pagina: Technical features and packing on page: Caractéristiques techniques et emballages à la page: Technische Eigenschaften und Verpackungen auf Seite: **498**

PEZZI SPECIALI TRIMS ACCESSOIRES FORMSTÜCKE

Battiscopa Bullnose
Plinthe à bord arrondi
Stehssockel
cm 9x30 - 3¹/₂"x11³/₄"

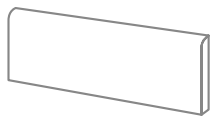

Terminale Pezzo unico pressato
Pièce unique pressée Pressed single piece
Gepresstes Einzelstück
cm 15x30x3,5 - 5⁷/₈"x11³/₄"x1³/₈"

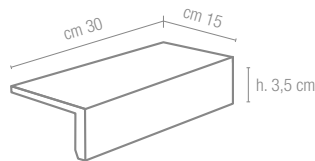

Tozzetto
Insert
Cabocho
Einleger
cm 9x9 - 3¹/₂"x3¹/₂"

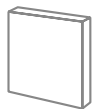

Gradone Piasentina
Pezzo unico Single piece
Une seule pièce
Einzelstück
cm 30x33 - 11³/₄"x11³/₄"

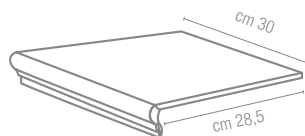

Angolare Piasentina
Pezzo unico Single piece
Une seule pièce
Einzelstück
cm 30x33 - 11³/₄"x11³/₄"

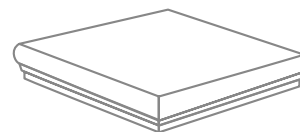

pietra piacentina

PIETRE NATIVE

piacentina cm 30x60 - 11³/₄"x23⁵/₈"

kerblock beige

kerblock

PIETRE NATIVE



kerblock beige cm 60x60 - 23⁵/₈"x23⁵/₈"

COLORI COLOURS COULEURS FARBEN

kerblock nero



kerblock piombo



kerblock beige



kerblock avorio

FORMATI SIZES FORMATS FORMATE

kerblock

PIETRE NATIVE

Formati Sizes
Formats Formate**cm 60x60**
23⁵/₈"x23⁵/₈"Superfici Surfaces
Surfaces Oberflächen

mm 20

Stonizzazione leggera
Shade variation subtle
Variations d'ombre légère
Farbtonvarianten Leicht● Naturale Matt Naturelle Matt **R11 A+B+C**

Rettificate in un unico calibro Rectified version in a single caliber Rectifiés en un unique calibre Boden Sie in einem einzigen Kaliber

Caratteristiche tecniche e imballi a pagina: Technical features and packing on page: Caractéristiques techniques et emballages à la page: Technische Eigenschaften und Verpackungen auf Seite: **498**

PEZZI SPECIALI TRIMS ACCESSOIRES FORMSTÜCKE

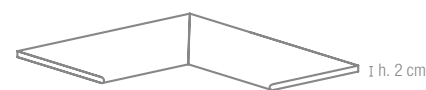
▲ 2pcs  45°**Art. 9640 Bordo**
cm 30x60 - 11³/₄"x23⁵/₈"**Art. 9642 Bordo angolare esterno ▲**
cm 30x60 - 11³/₄"x23⁵/₈"**Art. 9641 Bordo angolare interno ▲**
cm 30x60 - 11³/₄"x23⁵/₈"**kerblock piombo cm 60x60 - 23⁵/₈"x23⁵/₈"**

natural slate black

natural slate

GRANITOGRES



slate black cm 15x30 - 5⁷/₈"x11³/₄", cm 30x30 - 11³/₄"x11³/₄"

COLORI COLOURS COULEURS FARBEN

slate black



slate green



slate grey



slate red



slate gold







slate beige

FORMATI SIZES FORMATS FORMATE

natural slate

GRANITOGRES

Formati Sizes Formats Formate	 cm 15x15 5 ⁷ / ₈ "x5 ⁷ / ₈ "	 cm 15x30 5 ⁷ / ₈ "x 11 ³ / ₄ "	 cm 30x30 11 ³ / ₄ "x 11 ³ / ₄ "
Superfici Surfaces Surfaces Oberflächen	●	●	●
	mm 9	mm 9	mm 9 mm 9*



Stonalizzazione media
Shade variation medium
Variations d'ombre moyenne
Farbtonvarianten Mittel

● Naturale Matt Naturelle Matt **R10 A+B**

* Non rettificato Unrectified Non rectifié Nicht kalibriert

Rettificate in un unico calibro Rectified version in a single caliber Rectifiés en un unique calibre Boden Sie in einem einzigen Kaliber

Caratteristiche tecniche e imballi a pagina: Technical features and packing on page: Caractéristiques techniques et emballages à la page: Technische Eigenschaften und Verpackungen auf Seite: **494**

PEZZI SPECIALI TRIMS ACCESSOIRES FORMSTÜCKE

Battiscopa Bullnose
Plinthe à bord arrondi
Stehsockel
cm 9x30 - 3¹/₂"x11³/₄"

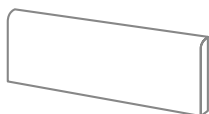

Gradino Step tread
Nez de marche **Stufenplatte**
cm 30x30 - 11³/₄"x11³/₄"

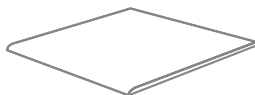

Terminale Pezzo unico
Pièce unique Single piece
Einzelstück
cm 15x30x3,5 - 5⁷/₈"x11³/₄"x1³/₈"

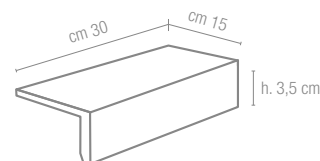

titano chambrod

titano

GRANITOGRES

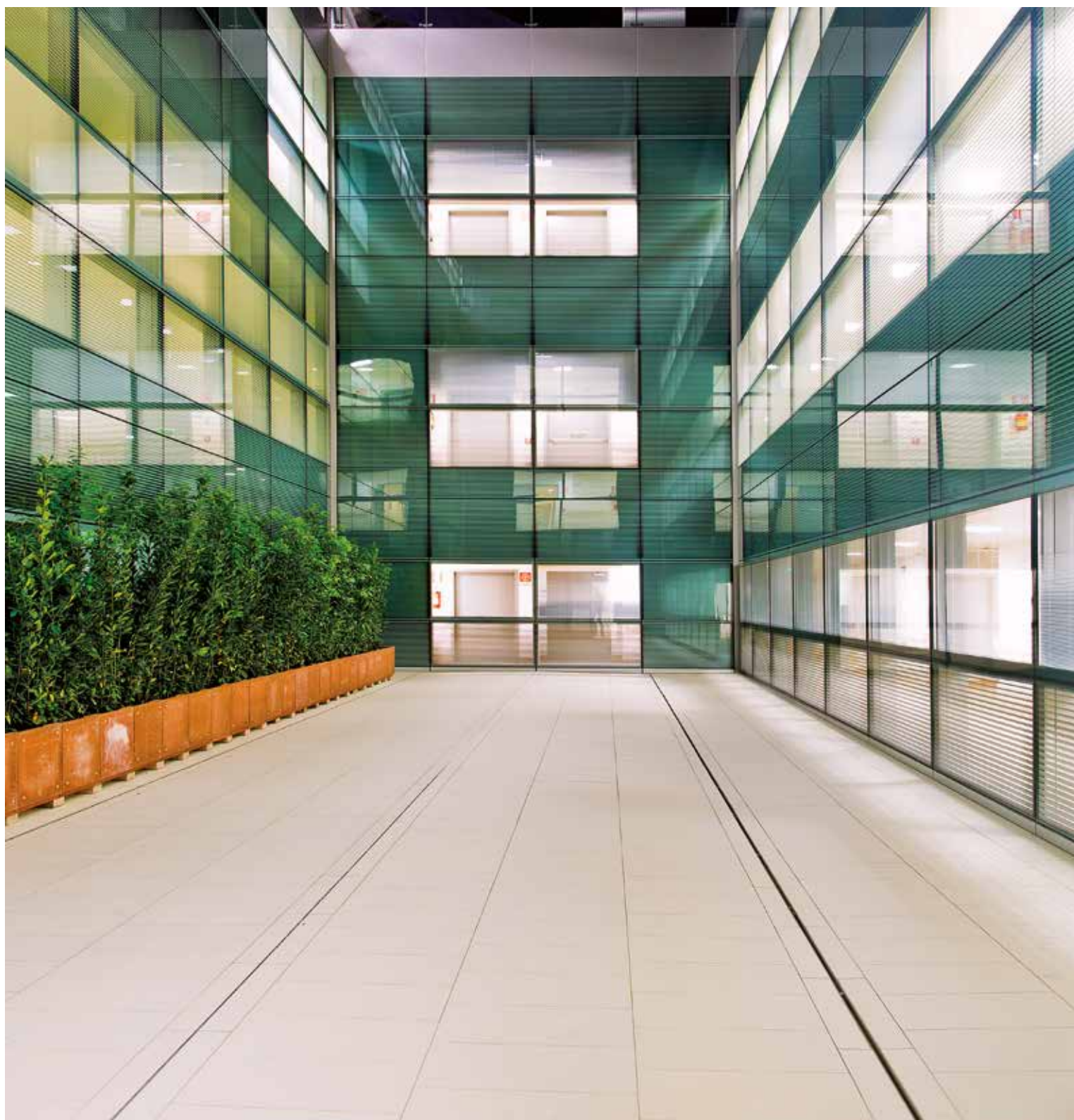

chambrod *bocciardata* cm 30x60 - 11³/₄"x23⁵/₈", 60x60 - 23⁵/₈"x23⁵/₈"

COLORI COLOURS COULEURS FARBEN

matraia



cardoso



chambrod

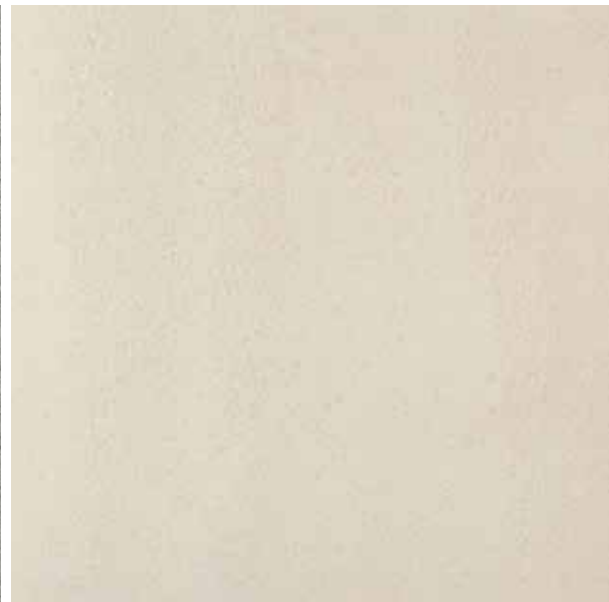

grigio ash



buxy



caen

SUPERFICI
SURFACES
SURFACES
OBERFLÄCHEN

titano
GRANITOGRES

champagne











levigata polished polie poliert

naturale matt naturelle matt R9

bocciardata bocciardata
bouchardée gehämmert
R11 A+B

FORMATI SIZES FORMATS FORMATE

		
Formati Sizes Formats Formate	cm 30x60 11 ³ / ₄ "x23 ⁵ / ₈ "	cm 60x60 23 ⁵ / ₈ "x23 ⁵ / ₈ "
Superfici Surfaces Surfaces Oberflächen		
	mm 10	mm 10
 Stonalizzazione media Shade variation medium Variations d'ombre moyenne Farbtonvarianten Mittel		<ul style="list-style-type: none">  Naturale Matt Naturelle Matt R9  Levigata Polished Polie Poliert  Bocciardata R11 A+B

* Spessore su superficie naturale Thickness on matt surface épaisseur sur surface mat Stärke der Fliesen mit Mattoberfläche

Rettificata in un unico calibro Rectified version in a single caliber Rectifiés en un unique calibre Boden Sie in einem einzigen Kaliber

Caratteristiche tecniche e imballi a pagina: Technical features and packing on page: Caractéristiques techniques et emballages à la page: Technische Eigenschaften und Verpackungen auf Seite: **494**

PEZZI SPECIALI TRIMS ACCESSOIRES FORMSTÜCKE

Battiscopa Bullnose
Plinthe à bord arrondi
Stehsokkel
cm 9x60 - 3¹/₂"x23⁵/₈"



Gradino Step tread
Nez de marche
Stufenplatte
cm 30x60 - 11³/₄"x23⁵/₈"

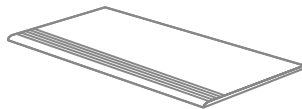

Angolare (assemblato)
cm 30x33 - 11³/₄"x47¹/₄"

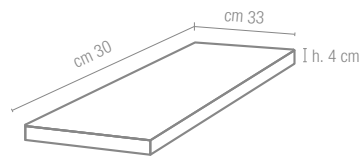

Gradone (assemblato)
cm 30x33 - 11³/₄"x47¹/₄"

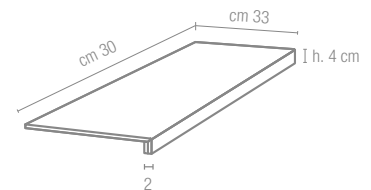

buxy bocciardata cm 60x60 - 23⁵/₈"x23⁵/₈"

titano

GRANITOGRES



grigio ash cm 60x60 - 23⁵/₈"x23⁵/₈"

ardesia nero

ardesia

GRANITOGRES

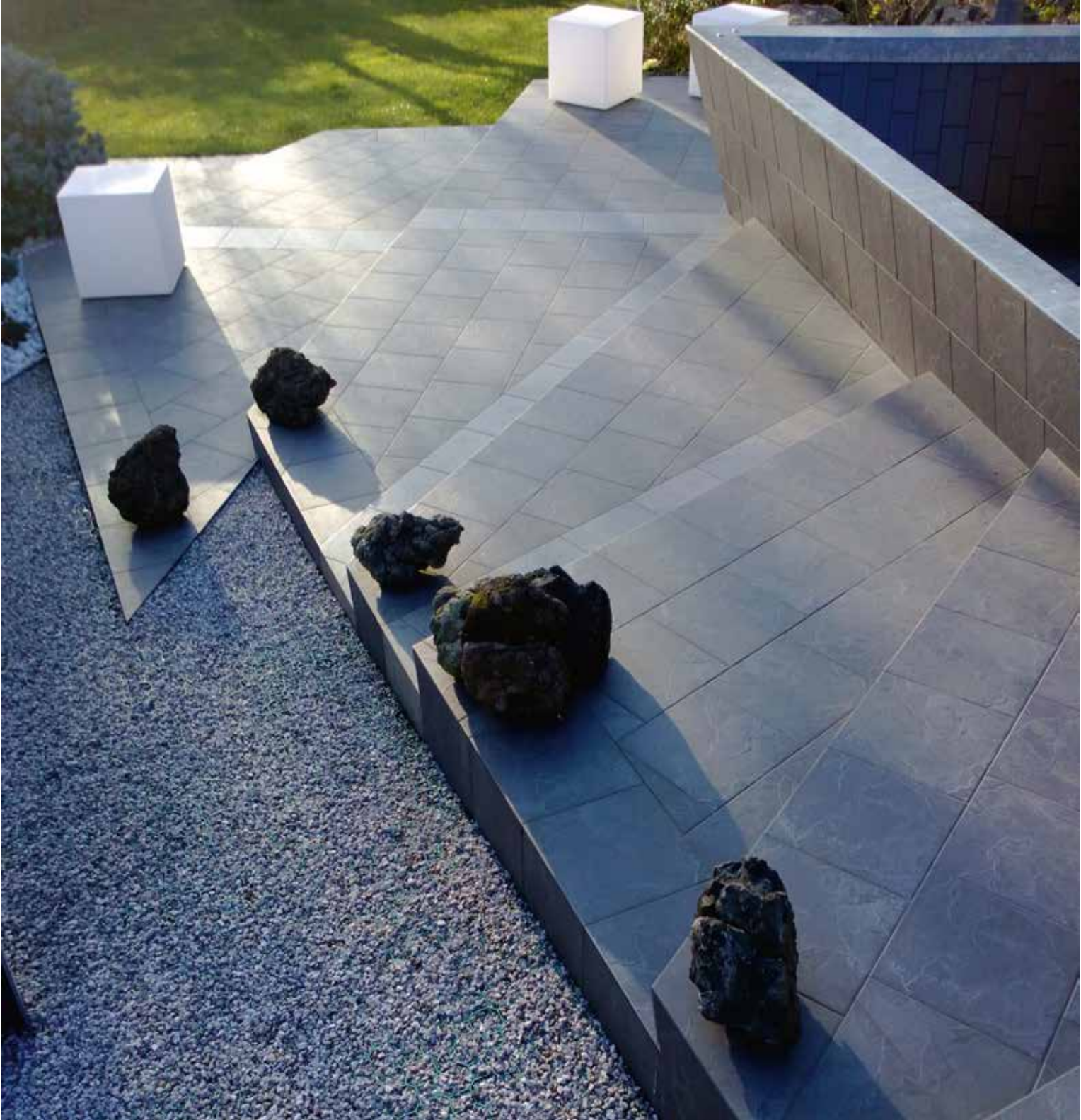

ardesia nero, ardesia grigio, ardesia bianco cm 30x30 - 11³/₄"x11³/₄"

COLORI COLOURS COULEURS FARBEN

ardesia nero



ardesia grigio



ardesia bianco



ardesia rosso



ardesia rosa











ardesia beige

FORMATI SIZES FORMATS FORMATE

ardesia

GRANITOGRES

Formati Sizes Formats Formate	 cm 15x15 57/8"x57/8"	 cm 15x30 57/8"x113/4"	 cm 30x30 113/4"x113/4"
Superfici Surfaces Surfaces Oberflächen			
	mm 8	mm 8	mm 8

 Stonalizzazione accentuata
Shade variation accentuated
Variations d'ombre forte
Farbtonvarianten Akzentuiert

 Naturale Matt Naturelle Matt **R10 A+B**

Caratteristiche tecniche e imballi a pagina: Technical features and packing on page: Caractéristiques techniques et emballages à la page: Technische Eigenschaften und Verpackungen auf Seite: **494**

PEZZI SPECIALI TRIMS ACCESSOIRES FORMSTÜCKE

Battiscopa Bullnose
Plinthe à bord arrondi
Stehsockel
cm 9x30 - 3 1/2"x11 3/4"

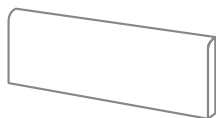

Gradino Step tread
Nez de marche
Stufenplatte
cm 30x30 - 11 3/4"x11 3/4"

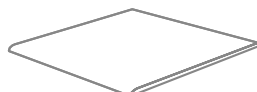

Terminale Pezzo unico
Pièce unique Single piece
Einzelstück
cm 15x30x3,5 - 5 7/8"x11 3/4"x1 3/8"

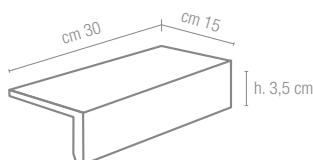

Gradone e gradone angolare rusticato
cm 30x30 - 11 3/4"x11 3/4"

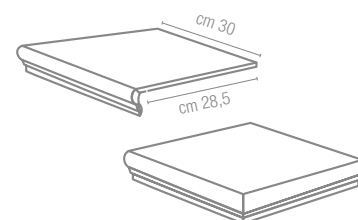

ardesia bianco cm 15x30 - 5 7/8"x11 3/4"

lavagna nera

lavagna

PIETRE NATIVE



lavagna nera, lavagna bianca cm 30x60 - 11³/₄"x23⁵/₈"

COLORI COLOURS COULEURS FARBEN

lavagna nera



lavagna grigia







lavagna bianca

FORMATI SIZES FORMATS FORMATE

lavagna

PIETRE NATIVE

Formati Sizes Formats Formate	 cm 15x15 5 ⁷ / ₈ "x5 ⁷ / ₈ "	 cm 30x30 11 ³ / ₄ "x 11 ³ / ₄ "	 cm 30x60 11 ³ / ₄ "x23 ⁵ / ₈ "	 cm 60x60* 23 ⁵ / ₈ "x23 ⁵ / ₈ "
Superfici Surfaces Surfaces Oberflächen	●	●	●	●
	mm 9	mm 9	mm 10* mm 9	mm 10



Stonizzazione leggera
Shade variation subtle
Variations d'ombre légère
Farbtonvarianten Leicht

● Naturale Matt Naturelle Matt **R10 A**

* Solo Lavagna nera Only Lavagna nera Seulement Lavagna nera Nur Lavagna nera

Rettificate in un unico calibro Rectified version in a single caliber Rectifiés en un unique calibre Boden Sie in einem einzigen Kaliber

Nel caso di combinazioni di formati di spessori diversi, specificarlo espressamente nell'ordine Please specify in your order if you wish to purchase formats including more than one thickness
Prière de spécifier dans votre commande si vous souhaitez acheter des formats avec différentes épaisseurs Bitte weisen Sie im Bestellungsformular ausdrücklich darauf hin, wenn Sie
Formatkombinationen mit verschiedenen Stärken wünschen

Caratteristiche tecniche e imballi a pagina: Technical features and packing on page: Caractéristiques techniques et emballages à la page: Technische Eigenschaften und Verpackungen auf Seite: **498**

PEZZI SPECIALI TRIMS ACCESSOIRES FORMSTÜCKE

Battiscopa Bullnose
Plinthe à bord arrondi
Stehsockel
cm 9x30 - 3¹/₂"x11³/₄"
cm 9x60 - 3¹/₂"x23⁵/₈"



Gradino Step tread
Nez de marche Stufenplatte
cm 30x30 - 11³/₄"x11³/₄"
cm 30x60 - 11³/₄"x23⁵/₈"

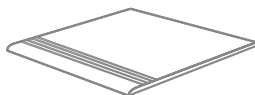

Terminale Pezzo incollato
Glued piece Pièce collée
Geklebter Stück
cm 15x30x5 - 5⁷/₈"x11³/₄"x2"

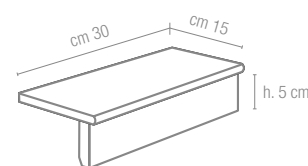

Tozzetto
Insert
Cabochon
Einleger
cm 9x9 - 3¹/₂"x3¹/₂"

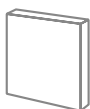

Listello
Listel
Listel
Zeierleiste
cm 9x30 - 3¹/₂"x11³/₄"



Scalino
e scalino angolare
cm 30x33 - 11³/₄"x13"

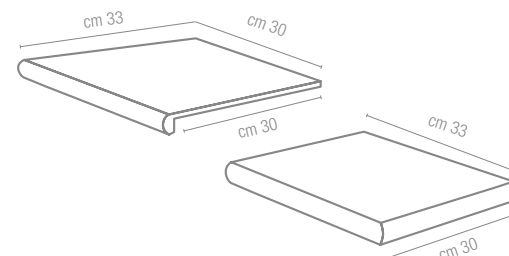

patio grey

patio

GRESPLUS

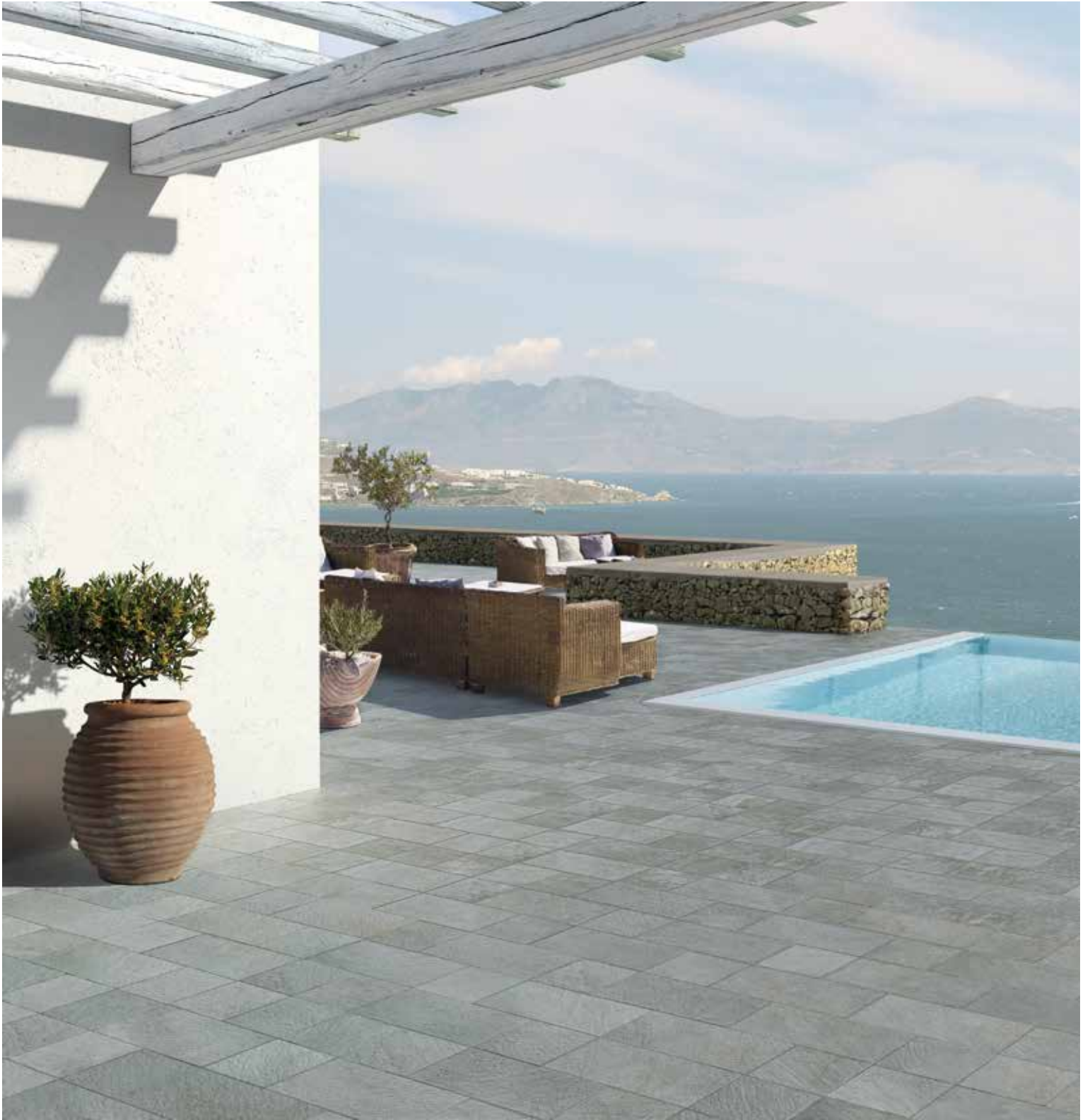

patio grey cm 20x20 - 7⁷/₈"x7⁷/₈", cm 20x40 - 7⁷/₈"x15³/₄"

COLORI COLOURS COULEURS FARBEN

patio black

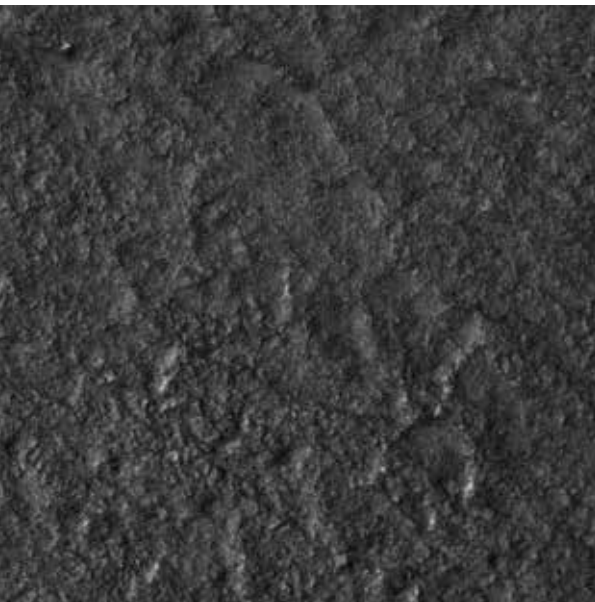

patio grey



patio white



patio brown



patio gold



patio beige

FORMATI SIZES FORMATS FORMATE

patio

GRESPLUS

Formati Sizes
Formats Formate



cm 20x20
7⁷/₈"x7⁷/₈"



cm 20x40
7⁷/₈"x 15³/₄"

Superfici Surfaces
Surfaces Oberflächen



mm 8

mm 8

 Stonalizzazione accentuata
Shade variation accentuated
Variations d'ombre forte
Farbtonvarianten Akzentuiert

● Naturale Matt Naturelle Matt **R11 A+B**

Caratteristiche tecniche e imballi a pagina: Technical features and packing on page: Caractéristiques techniques et emballages à la page: Technische Eigenschaften und Verpackungen auf Seite: **504**

PEZZI SPECIALI TRIMS ACCESSOIRES FORMSTÜCKE

Battiscopa
Bullnose
Plinthe à bord arrondi
Stehsokkel
cm 9x40 - 3¹/₂"x15³/₄"

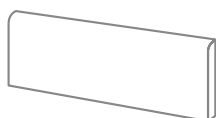

Terminale Pezzo unico pressato
Pièce unique pressée
Pressed single piece
Gepresstes Einzelstück
cm 15x30x3,5 - 5⁷/₈"x11³/₄"x1³/₈"

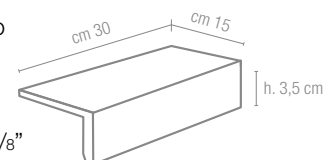

patio gold cm 20x40 - 7⁷/₈"x15³/₄"

agorà megalopoli



sparta, corinto cm 15x15 - 5⁷/₈"x5⁷/₈", 15x30 - 5⁷/₈"x11³/₄", 30x30 - 11³/₄"x11³/₄"

COLORI COLOURS COULEURS FARBEN

elatea



megalopoli









corinto

sparta

FORMATI SIZES FORMATS FORMATE



Formati Sizes Formats Formate	 cm 15x15 57/8"x57/8"	 cm 15x30 57/8"x113/4"	 cm 30x30 113/4"x113/4"
Superfici Surfaces Surfaces Oberflächen			
	mm 8	mm 8	mm 8



● Naturale Matt Naturelle Matt R11 A+B

Caratteristiche tecniche e imballi a pagina: Technical features and packing on page: Caractéristiques techniques et emballages à la page: Technische Eigenschaften und Verpackungen auf Seite: **494**

PEZZI SPECIALI TRIMS ACCESSOIRES FORMSTÜCKE

Battiscopa Bullnose
Plinthe à bord arrondi
Stehsokkel
cm 9x30 - 3 1/2"x11 3/4"



Gradino Step tread
Nez de marche
Stufenplatte
cm 30x30 - 11 3/4"x11 3/4"

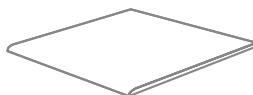

Terminale Pezzo unico
Pièce unique Single piece
Einzelstück
cm 15x30x3,5 - 57/8"x11 3/4"x1 3/8"

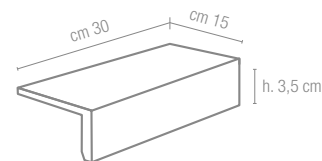

sparta, corinto cm 15x15 - 57/8"x57/8", 15x30 57/8"x113/4", 30x30 - 113/4"x113/4"

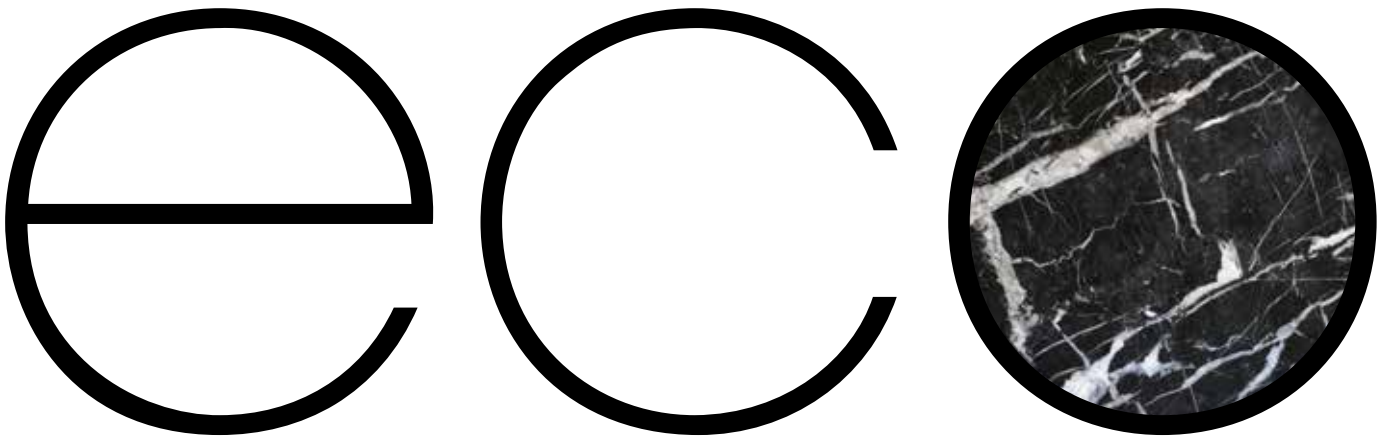

eco**marble** éco**marbre** öko**marmor**

marmo

ecomarmo

180 marmoker

206 marte

222 onici

MARMO

Roccia cristallina, da decorazione e costruzione, lucidabile e di natura compatta prevalentemente costituita da minerale di durezza Mohs da 3 a 4, quali calciti, dolomiti e serpentini. In funzione della sua composizione mineralogica la roccia cristallina può essere sintetizzata in quattro grandi categorie: alla prima appartengono i marmi propriamente detti [ovvero calcari metamorfici ricristallizzati], i calcefiri e i cipollini.

Alla seconda i calcari, le dolomie e le breccie calcaree lucidabili. Alla terza i serpentini. Alla quarta le oficalciti.

MARBLE

Crystalline rock for building and decorative purposes that can be polished. Characterized by a compact nature, it mainly consists of minerals with 3 to 4 Mohs hardness, such as calcites, dolomites and serpentine rocks. Depending on its mineralogical composition, crystalline rock can be roughly divided into four large categories: marbles in the strict sense belong to the first category [i.e. recrystallized metamorphic limestones], along with calciferous and carystium rocks. The second category includes limestones, dolomites and limestone breccia fit for polishing. Serpentine rocks belong to the third category and ophicalcites to the fourth.



marmoker bardiglio imperiale

marmoker

GRANITOKER

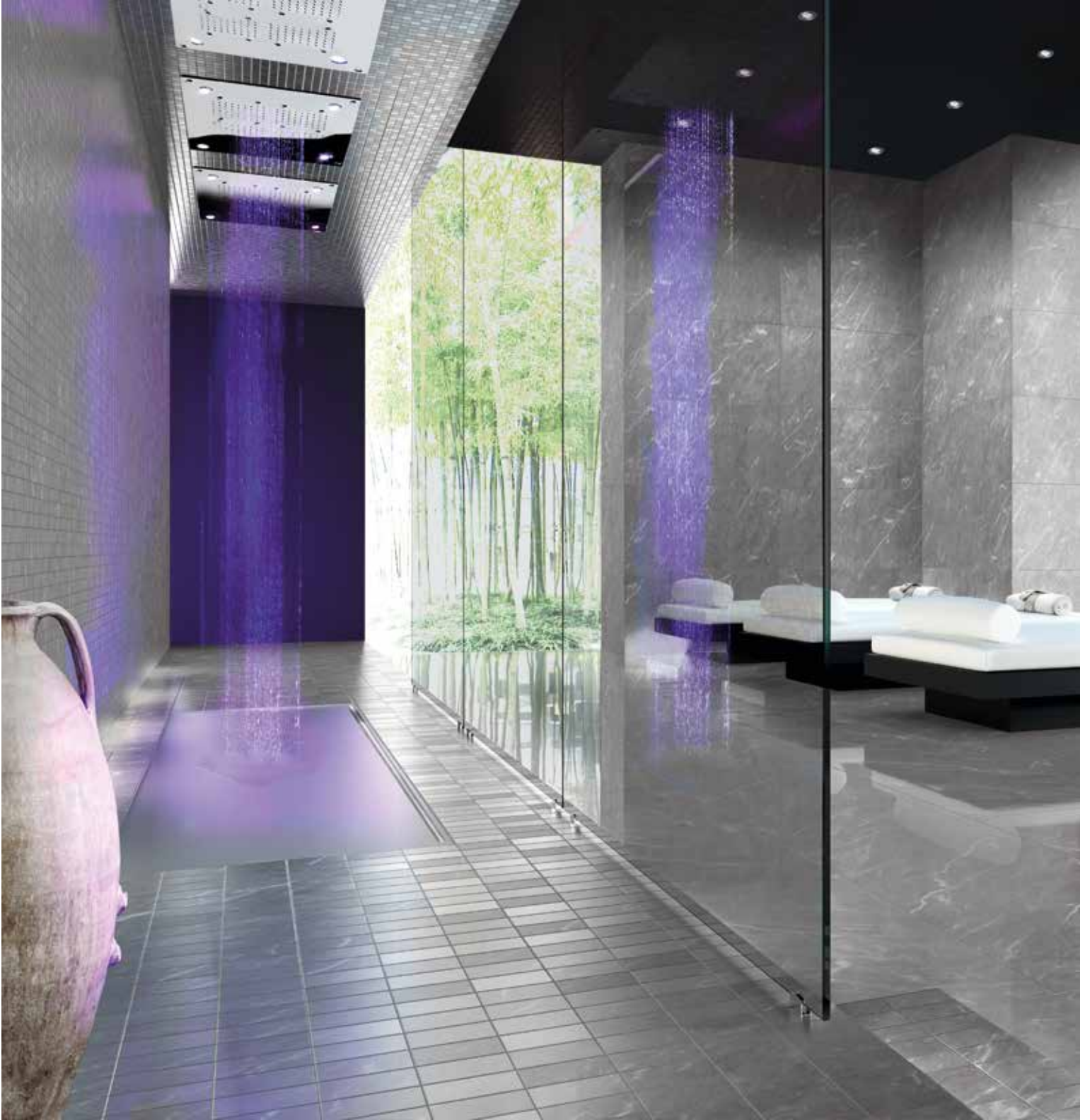

bardiglio imperiale lucida cm 59x118 - 23¹/₄"x46¹/₂", **mosaico**, **mosaico 5x10** cm 29,5x29,5 - 11⁵/₈"x11⁵/₈"

COLORI COLOURS COULEURS FARBEN

nero creta



grafite

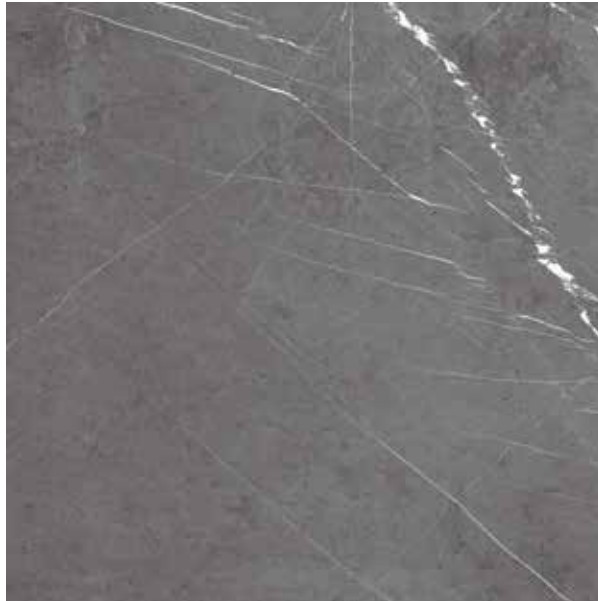

breccia carsica

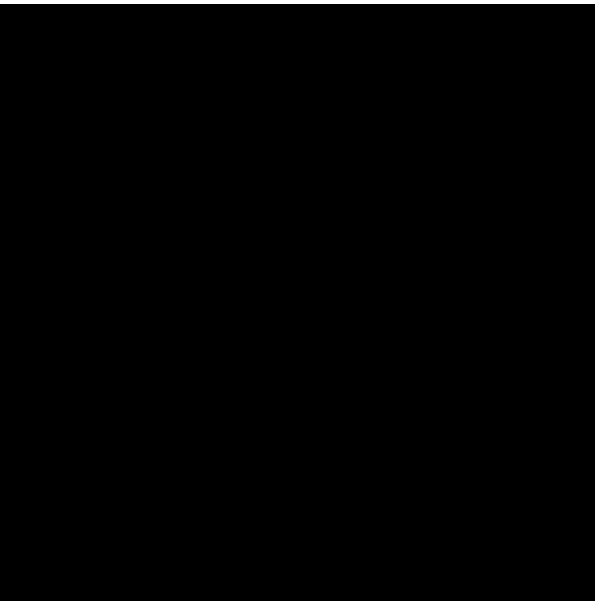

ossidiana



travertino moka



saint laurent

marmoker

GRANITOKER

bardiglio imperiale



pulpis tortora



travertino noce



birimbau



grigio billiemi



travertino titanium

COLORI COLOURS COULEURS FARBEN

verde aver



breccia sarda



travertino s. caterina



jolie



giallo striato



travertino romano

marmoker

GRANITOKER

travertino miele



fiorito



arabesque



crema select



rosato



silvia oro

COLORI COLOURS COULEURS FARBEN

breccia argento



olimpo



travertino bianco



zebrino

bardiglio bianco

bianco vietnam

marmoker

GRANITOKER

veselye



statuario grigio



statuario oro





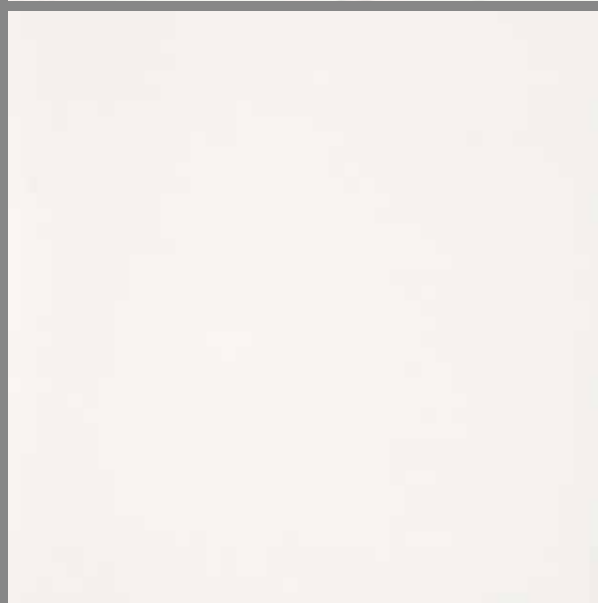







asiago



canova

FORMATI SIZES FORMATS FORMATE

								
Formati Sizes Formats Formate	cm 9,8x59 3 ⁷ / ₈ "x23 ¹ / ₄ "	cm 29,5x59 11 ⁵ / ₈ "x23 ¹ / ₄ "	cm 59x59 23 ¹ / ₄ "x23 ¹ / ₄ "	cm 29,5x118 11 ⁵ / ₈ "x46 ¹ / ₂ "	cm 59x118 23 ¹ / ₄ "x46 ¹ / ₂ "	cm 45x90 17 ³ / ₄ "x35 ⁵ / ₈ "	cm 90x90 35 ⁵ / ₈ "x35 ⁵ / ₈ "	cm 90x180 35 ⁵ / ₈ "x70 ⁷ / ₈ "
Arabesque						● ●	● ●	● ●
Asiago	● ●	● ●	● ●	● ●	● ●			
Bardiglio Bianco	● ●	● ●	● ●	● ●	● ●			
Bardiglio Imperiale	● ●	● ●	● ●	● ●	● ●			
Bianco Vietnam						● ●	● ●	● ●
Birimbau	● ●	● ●	● ●	● ●	● ●			
Breccia Argento	● ●	● ●	● ●	● ●	● ●			
Breccia Carsica	● ●	● ●	● ●	● ●	● ●	● ●	● ●	● ●
Breccia Sarda						● ●	● ●	● ●
Canova	● ●	● ●	● ●	● ●	● ●			
Crema Select	● ●	● ●	● ●	● ●	● ●			
Fiorito						● ●	● ●	● ●
Giallo Striato	● ●	● ●	● ●	● ●	● ●			
Grafite	● ●	● ●	● ●	● ●	● ●	● ●	● ●	● ●
Grigio Billiemi						● ●	● ●	● ●
Jolie	● ●	● ●	● ●	● ●	● ●	● ●	● ●	● ●
Nero Creta	● ●	● ●	● ●	● ●	● ●			
Olimpo	● ●	● ●	● ●	● ●	● ●			
Ossidiana								
Pulpis Tortora	● ●	● ●	● ●	● ●	● ●			
Rosato	● ●	● ●	● ●	● ●	● ●			
Saint Laurent	● ●	● ●	● ●	● ●	● ●			
Silvia Oro						● ●	● ●	● ●
Statuario Grigio	● ●	● ●	● ●	● ●	● ●	● ●	● ●	● ●
Statuario Oro	● ●	● ●	● ●	● ●	● ●			
Travertino Bianco	● ●	● ●	● ●	● ●	● ●			
Travertino Miele	● ●	● ●	● ●	● ●	● ●			
Travertino Moka	● ●	● ●	● ●	● ●	● ●			
Travertino Noce	● ●	● ●	● ●	● ●	● ●			
Travertino Romano	● ●	● ●	● ●	● ●	● ●			
Travertino Titanium	● ●	● ●	● ●	● ●	● ●	● ●	● ●	● ●
Travertino Santa Caterina	● ●	● ●	● ●	● ●	● ●			
Verde Aver	● ●	● ●	● ●	● ●	● ●	● ●	● ●	● ●
Veselye						● ●	● ●	● ●
Zebrino	● ●	● ●	● ●	● ●	● ●			
 mm 10	mm 10	mm 10	mm 10	mm 10	mm 10	mm 10	mm 10	mm 10
								

Rettificata in un unico calibro Rectified version in a single caliber Rectifiés en un unique calibre Boden Sie in einem einzigen Kaliber

Caratteristiche tecniche e imballi a pagina: Technical features and packing on page:

Caractéristiques techniques et emballages à la page: Technische Eigenschaften und Verpackungen auf Seite: **501**

- Naturale Matt Naturelle Matt **R9**
- * Naturale Matt Naturelle Matt
- Lucida



cm 59x118
23¹/₄"x46¹/₂"

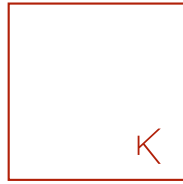

cm 118x118
46¹/₂"x46¹/₂"

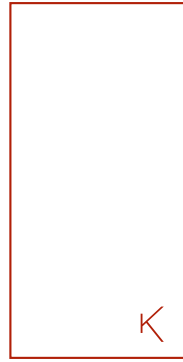

cm 118x236
46¹/₂"x92⁷/₈"

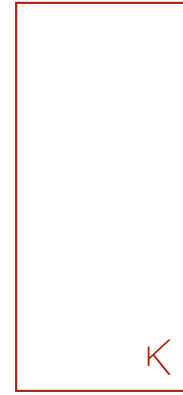

cm 118x258
46¹/₂"x101⁵/₈"

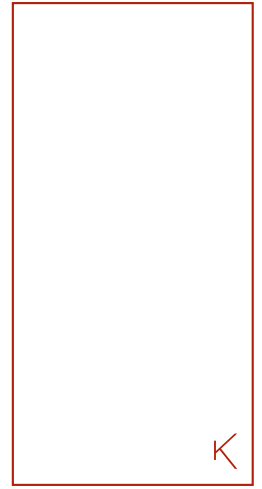

cm 160x320
63"x126"



mm 6,5

mm 10
mm 6,5

mm 6,5

mm 6,5

mm 12

K Lastre K_ontinua
K_ontinua Slabs
Dalles K_ontinua
K_ontinua Platten

PEZZI SPECIALI TRIMS ACCESSOIRES FORMSTÜCKE

- Naturale Matt Naturelle Matt
- Lucida

Battiscopa Bullnose
Plinthe à bord arrondi
Stehssockel
cm 9x59 - 3½"x23¼"
cm 9x90 - 3½"x35⅜"



esagono
cm 30x51,9
11¾"x20⅜"

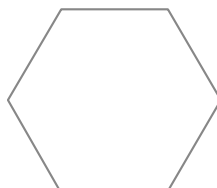

Tozzetto Insert
Cabochon Einleger
cm 9,8x9,8 - 3⅞"x 3⅞"

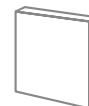

Gradino Step tread
Nez de marche **Stufenplatte**
cm 29,5x59 - 11¾"x23¼"
cm 30x90 - 11⅝"x35⅜"

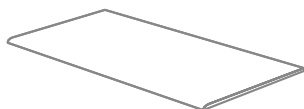

Gradone (assemblato)
cm 118x33 - 46½"x13"
cm 180x33 - 70⅞"x13"

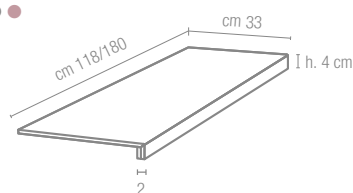

Angolare (assemblato)
cm 118x33 - 46½"x13"
cm 180x33 - 70⅞"x13"

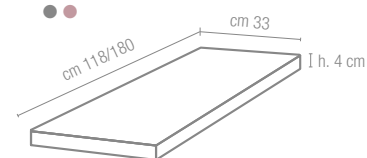

statuario grigio *lucida* cm 90x180 - 35⅜"x70⅞", grafite *matt* cm 90x90 - 35⅜"x35⅜"

SUPERFICI SURFACES
SURFACES OBERFLÄCHEN

marmoker

GRANITOKER

lucida

naturale matt
naturelle **matt**

Kontinua COMPOSIZIONE BOOKMATCH

cm 118x236 | cm 118x258

statuario grigio

Rettificate in un unico calibro
Single caliber, rectified version
Rectifiés en un unique calibre
Einem einzigen Werkmass
maßgeschliffen geliefert

statuario grigio **A**



statuario grigio **A sp**



statuario oro **A**



statuario oro **A sp**



Kontinua COMPOSIZIONE BOOKMATCH

cm 118x236 | cm 118x258

marmoker

GRANITOKER

statuario grigio

Rettificate in un unico calibro
 Single caliber, rectified version
 Rectifiés en un unique calibre
 Einem einzigen Werkmass
 maßgeschliffen geliefert

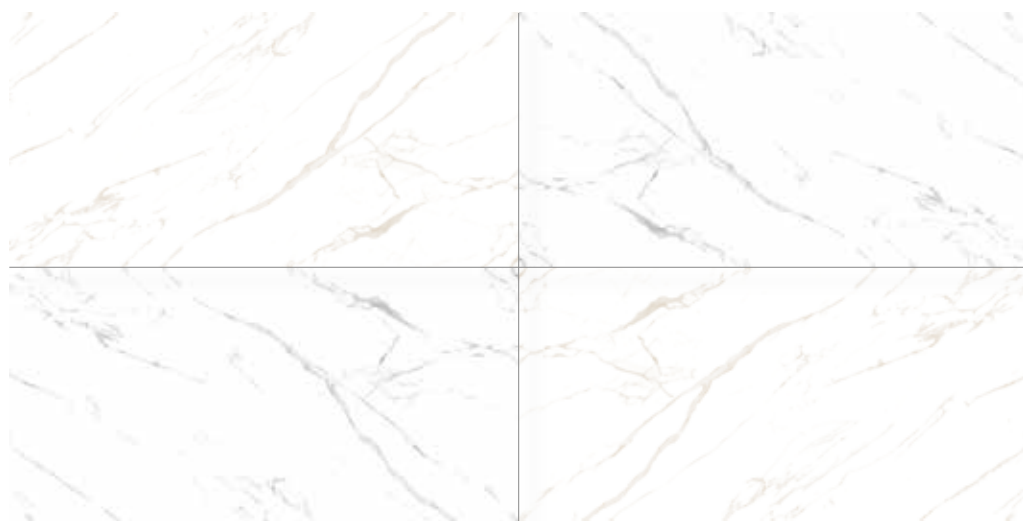
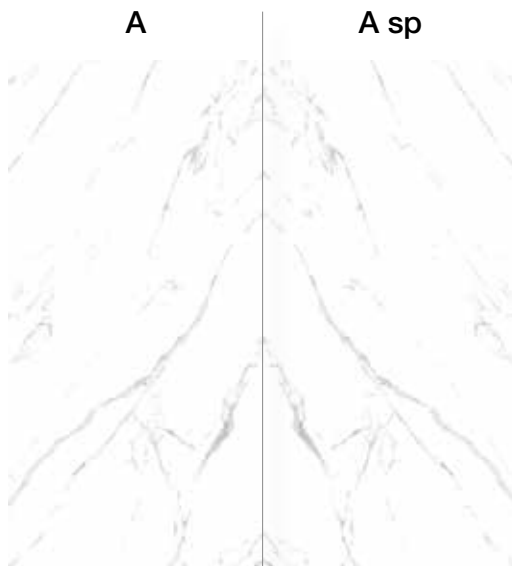

A sp	A
A	A sp

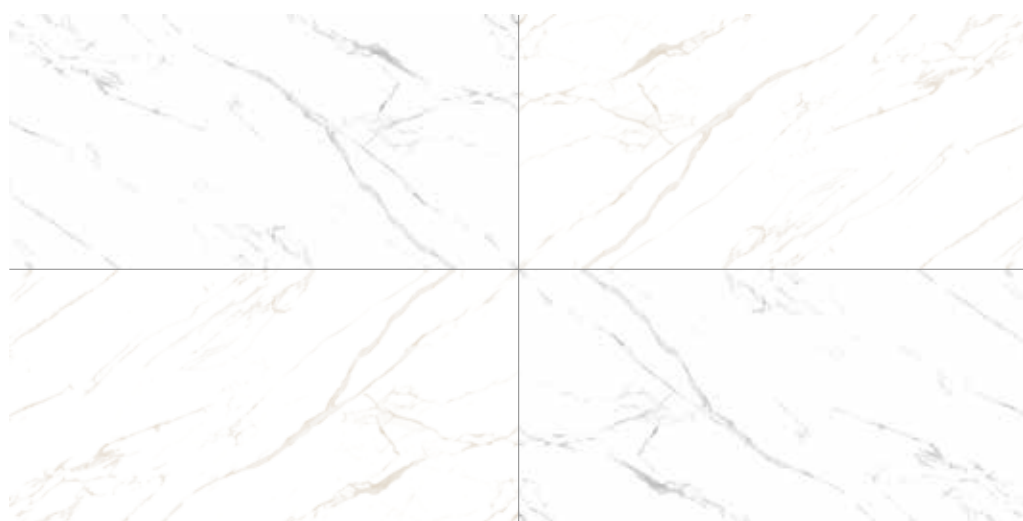

A	A sp
A sp	A

Kontinua COMPOSIZIONE BOOKMATCH

cm 118x236 | cm 118x258

statuario oro

Rettificate in un unico calibro
 Single caliber, rectified version
 Rectifiés en un unique calibre
 Einem einzigen Werkmass
 maßgeschliffen geliefert

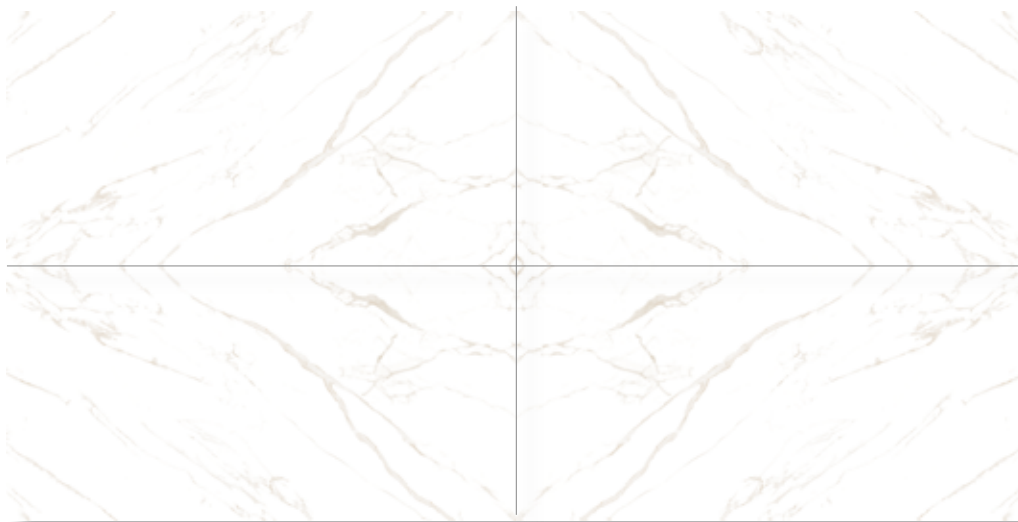
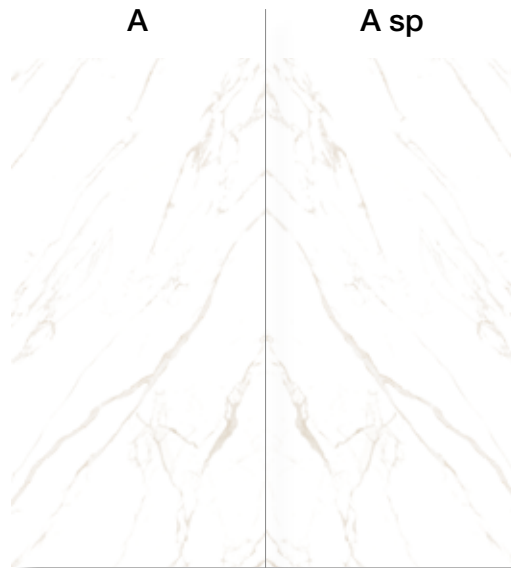

A sp	A
A	A sp

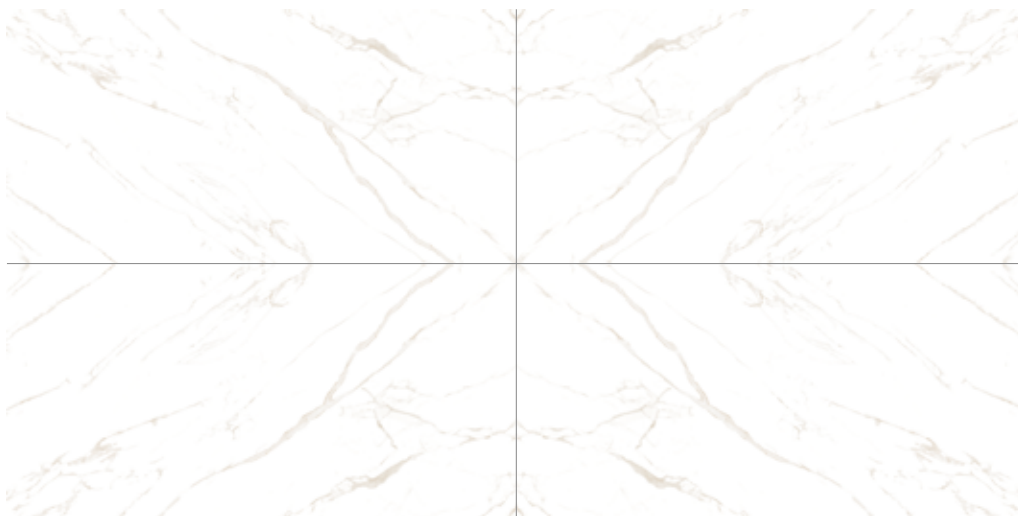

A	A sp
A sp	A

Kontinua COMPOSIZIONE BOOKMATCH

cm 118x236 | cm 118x258

marmoker

GRANITOKER

arabesque

Rettificate in un unico calibro
 Single caliber, rectified version
 Rectifiés en un unique calibre
 Einem einzigen Werkmass
 maßgeschliffen geliefert

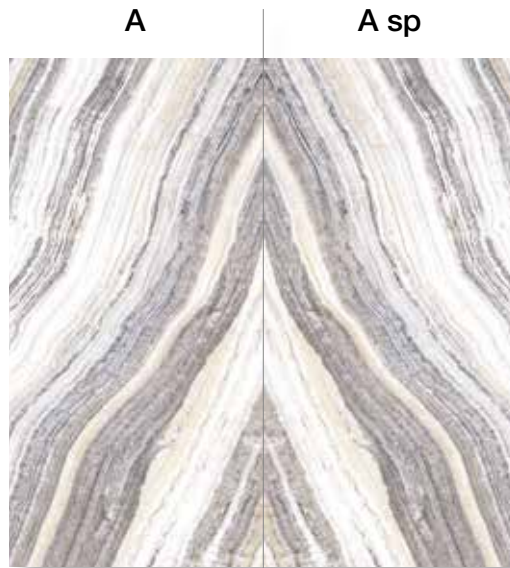

A sp	A
A	A sp



A	A sp
A sp	A

Kontinua COMPOSIZIONE ENDMATCH

cm 118x236 | cm 118x258

statuario grigio

Rettificate in un unico calibro
Single caliber, rectified version
Rectifiés en un unique calibre
Einem einzigen Werkmass
maßgeschliffen geliefert

statuario grigio **A**statuario grigio **B**statuario grigio **C**statuario grigio **D**

statuario oro

Rettificate in un unico calibro
Single caliber, rectified version
Rectifiés en un unique calibre
Einem einzigen Werkmass
maßgeschliffen geliefert

statuario oro **A**statuario oro **B**statuario oro **C**statuario oro **D**

marmoker

GRANITOKER



Statuario Oro Endmatch cm 118x258 - 46 $\frac{1}{2}$ "x101 $\frac{5}{8}$ "
Statuario Oro cm 118x118 - 46 $\frac{1}{2}$ "x46 $\frac{1}{2}$ "

DECORI DECORS DÉCORS DEKORE

mosaico*

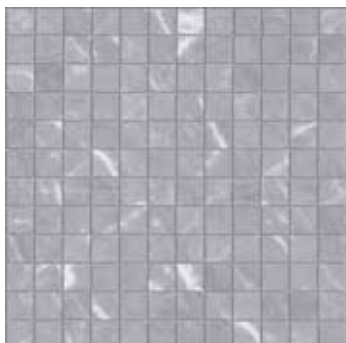

cm 29,5x29,5 - 11⁵/₈"x11⁵/₈"
 tessera cm 2,3x2,3 - 1"x1"
 su rete on net sur trame auf Netz

▼
▲ mm 10

Kontinua ▼
▲ mm 6,5

Superficie naturale e lucida Matt and lucida surface
 Surface naturelle et lucida Matte und lucida Oberfläche

mosaico 5x10**



cm 29,5x29,5 - 11⁵/₈"x11⁵/₈"
 tessera cm 5x10 - 2"x4"
 su rete on net sur trame auf Netz

▼
▲ mm 10

Kontinua ▼
▲ mm 6,5

Superficie naturale e lucida Matt and lucida surface
 Surface naturelle et lucida Matte und lucida Oberfläche

mosaico decoro*

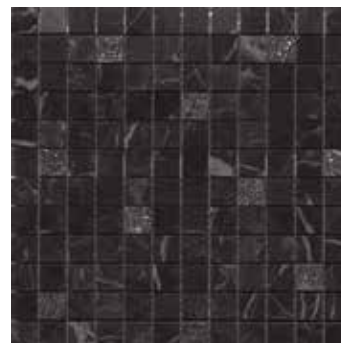

cm 29,5x29,5 - 11⁵/₈"x11⁵/₈"
 tessera cm 2,3x2,3 - 1"x1"
 su rete on net sur trame auf Netz

▼
▲ mm 10

Solo superficie lucida Lucida surface only
 Seulement surface lucida Nur in lucida Oberfläche

london***



cm 5x29,5 - 2"x11⁵/₈"
 cm 5x30 - 2"x11³/₄"

zoccolo***



cm 12,5x29,5 - 4⁷/₈"x11⁵/₈"
 cm 12,5x30 - 4⁷/₈"x11³/₄"

terminale***



cm 1x29,5 - 3/8"x11⁵/₈"
 cm 1x30 - 3/8"x11³/₄"

spigolo london***



cm 5x2,5 - 2"x1"

spigolo zoccolo***



cm 12,5x2,5 - 4⁷/₈"x1"

spigolo terminale***



cm 1x1 - 3/8"x3/8"

cassettone travertino****



cm 29,5x29,5 - 11⁵/₈"x 11⁵/₈"
 su rete on net sur trame auf Netz

Solo superficie lucida
 Lucida surface only
 Seulement surface lucida
 Nur in lucida Oberfläche

quadrotte****

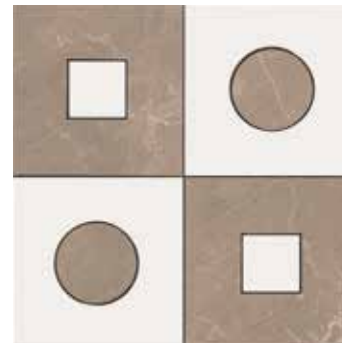

cm 29,5x29,5 - 11⁵/₈"x 11⁵/₈"
 su rete on net sur trame auf Netz

Solo superficie lucida
 Lucida surface only
 Seulement surface lucida
 Nur in lucida Oberfläche

* Disponibile in tutti i colori della serie Available in all the colours of the series Disponible dans tous les couleurs e la série Verfügbar in allen farben

** Disponibile nei colori: Available in the colours: Disponible dans les couleurs: Verfügbar in den folgenden Farben: Bardiglio Imperiale, Nero Creta, Pulpis Tortora, Saint Laurent, Statuario Grigio

*** Disponibile in tutti i colori della serie. Solo superficie lucida Available in all the colours of the series. Lucida surface only
 Disponible dans tous les couleurs de la série. Seulement surface lucida Verfügbar in allen farben. Nur in lucida Oberfläche

**** Disponibile nei colori: Available in the colours: Disponible dans les couleurs: Verfügbar in den folgenden Farben A: Canova, Bardiglio Imperiale, B: Canova, Nero Creta, C: Canova, Pulpis tortora

marmoker

GRANITOKER

mosaico*

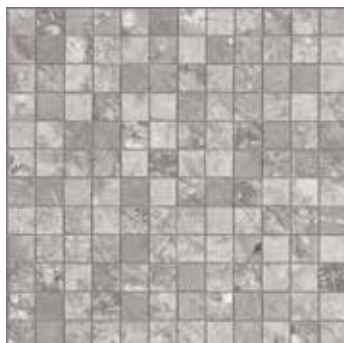

cm 30x30 - 11³/₄"x11³/₄"
 tessera **cm 2,3x2,3** - 1"x1"
 su rete on net sur trame auf Netz

composizione D*

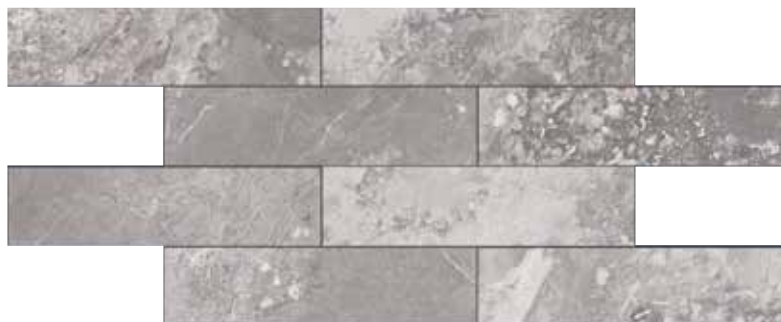

cm 28,5x57,6 - 11¹/₄"x22⁵/₈"
 ogni mattoncino: **cm 7x28,7** - 2³/₄"x11¹/₄"
 su rete on net sur trame auf Netz

mosaico 5x10*



cm 30x30 - 11³/₄"x 11³/₄"
 tessera **cm 5x10** - 2"x4"
 su rete on net sur trame auf Netz



mosaico decoro nero creta lucida
 cm 29,5x29,5 - 11⁵/₈"x11⁵/₈"
nero creta, statuario grigio lucida
 cm 59x118 - 23¹/₄"x46¹/₂"

* Disponibile in tutti i colori della serie.
 Solo superficie lucida
 Available in all the colours of the series.
 Lucida surface only
 Disponible dans tous les couleurs e la série.
 Seulement surface lucida
 Verfügbar in allen farben.
 Nur in lucida Oberfläche

DECORI DECORS DÉCORS DEKORE

mosaico cascata A

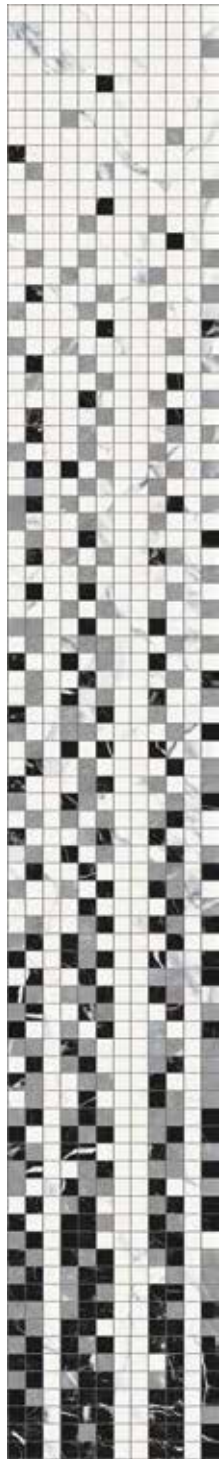

cm 29,5x206,5 - 11⁵/₈"x81¹/₄"
 tessera **cm 2,3x2,3 - 1"x1"**
su rete on net sur trame auf Netz
statuario grigio, nero creta, bardiglio imperiale

Solo superficie lucida Lucida surface only
 Seulement surface lucida Nur in lucida Oberfläche

mosaico cascata B

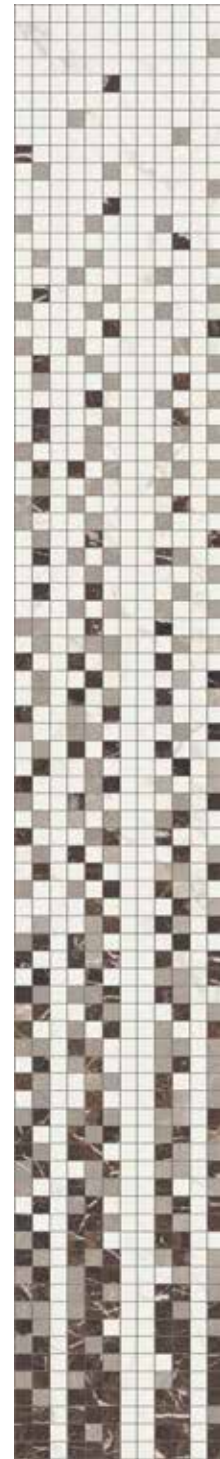

cm 29,5x206,5 - 11⁵/₈"x81¹/₄"
 tessera **cm 2,3x2,3 - 1"x1"**
su rete on net sur trame auf Netz
pulpis tortora, saint laurent, statuario oro

Solo superficie lucida Lucida surface only
 Seulement surface lucida Nur in lucida Oberfläche

marmoker

GRANITOKER

mosaico
cascata A
lucida
cm 29,5x206,5
11⁵/₈"x81¹/₄"
canova *lucida*
cm 59x59
23¹/₄"x23¹/₄"

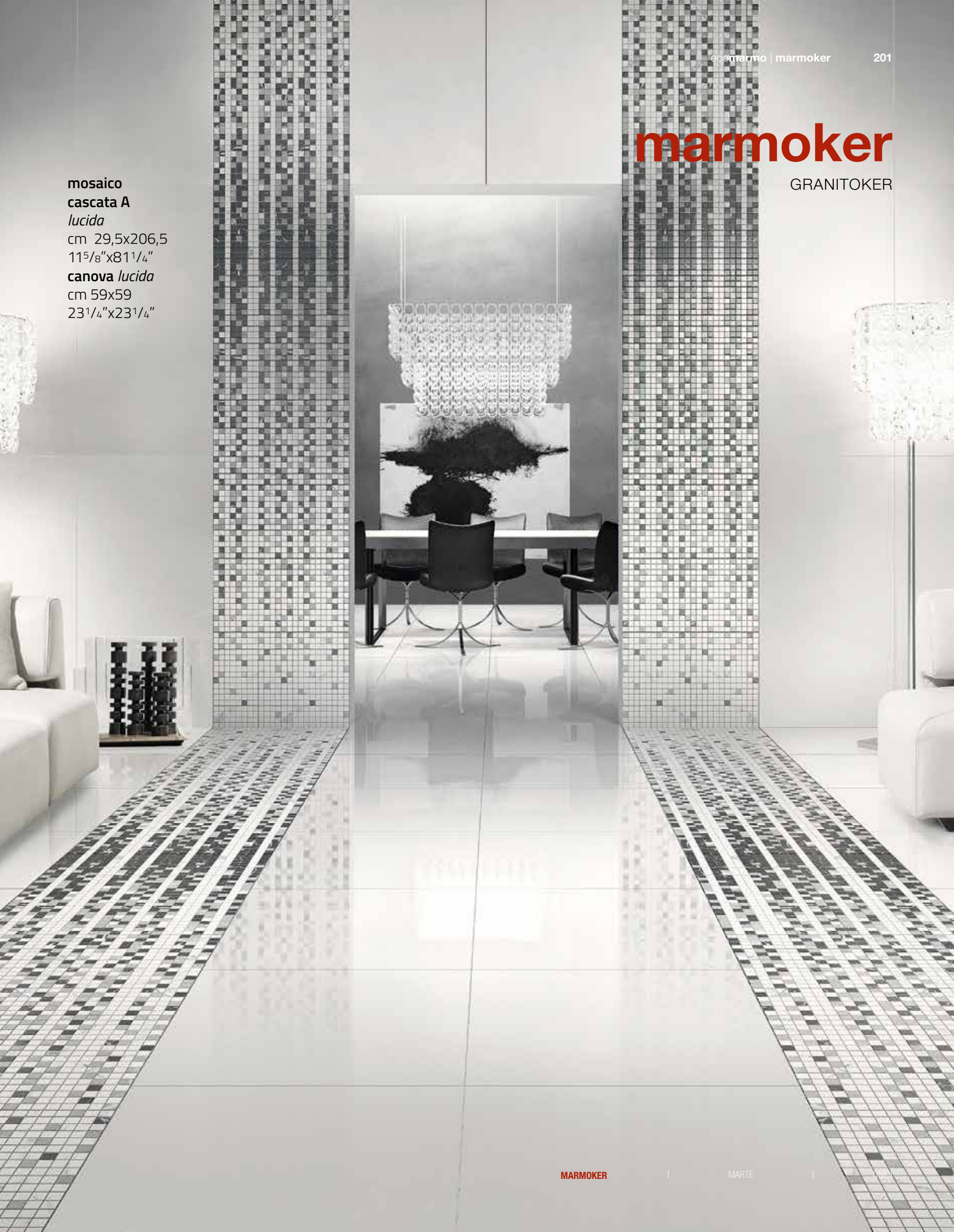

DECORI DECORS DÉCORS DEKORE

decoro statuario oro*

cm 29,5x59 - 11⁵/₈"x23¹/₄"Solo superficie lucida Lucida surface only
Seulement surface lucida
Nur in lucida Oberfläche

decoro saint laurent*

cm 29,5x59 - 11⁵/₈"x23¹/₄"Solo superficie lucida Lucida surface only
Seulement surface lucida
Nur in lucida Oberfläche

decoro nero creta**

cm 29,5x59 - 11⁵/₈"x23¹/₄"Solo superficie lucida Lucida surface only
Seulement surface lucida
Nur in lucida Oberfläche

decoro statuario grigio**

cm 29,5x59 - 11⁵/₈"x23¹/₄"Solo superficie lucida Lucida surface only
Seulement surface lucida
Nur in lucida Oberfläche

listello decoro*

cm 5x29,5 - 2"x11⁵/₈"Solo superficie lucida Lucida surface only
Seulement surface lucida
Nur in lucida Oberfläche

listello decoro**

cm 5x29,5 - 2"x11⁵/₈"Solo superficie lucida Lucida surface only
Seulement surface lucida
Nur in lucida Oberflächelistello marmoker
orocm 2x29,5 - 3/4"x11⁵/₈"Solo superficie lucida Lucida surface only
Seulement surface lucida
Nur in lucida Oberflächelistello marmoker
argentocm 2x29,5 - 3/4"x11⁵/₈"Solo superficie lucida Lucida surface only
Seulement surface lucida
Nur in lucida Oberfläche* Disponibile nei colori: Available in the colours: Disponible dans les couleurs: Verfügbar in den folgenden Farben: **pulpis tortora, saint laurent, statuario oro**** Disponibile nei colori: Available in the colours: Disponible dans les couleurs: Verfügbar in den folgenden Farben: **nero creta, statuario grigio**

decoro saint laurent cm 29,5x59 - 11⁵/₈"x23¹/₄"
listello marmoker oro cm 2x29,5 - 3³/₄"x11⁵/₈"
saint laurent, statuario oro lucida cm 59x59 - 23¹/₄"x23¹/₄"
cm 9,8x59 - 37⁷/₈"x23¹/₄"

marmoker

GRANITOKER

DECORI DECORS DÉCORS DEKORE

rosone marmoker

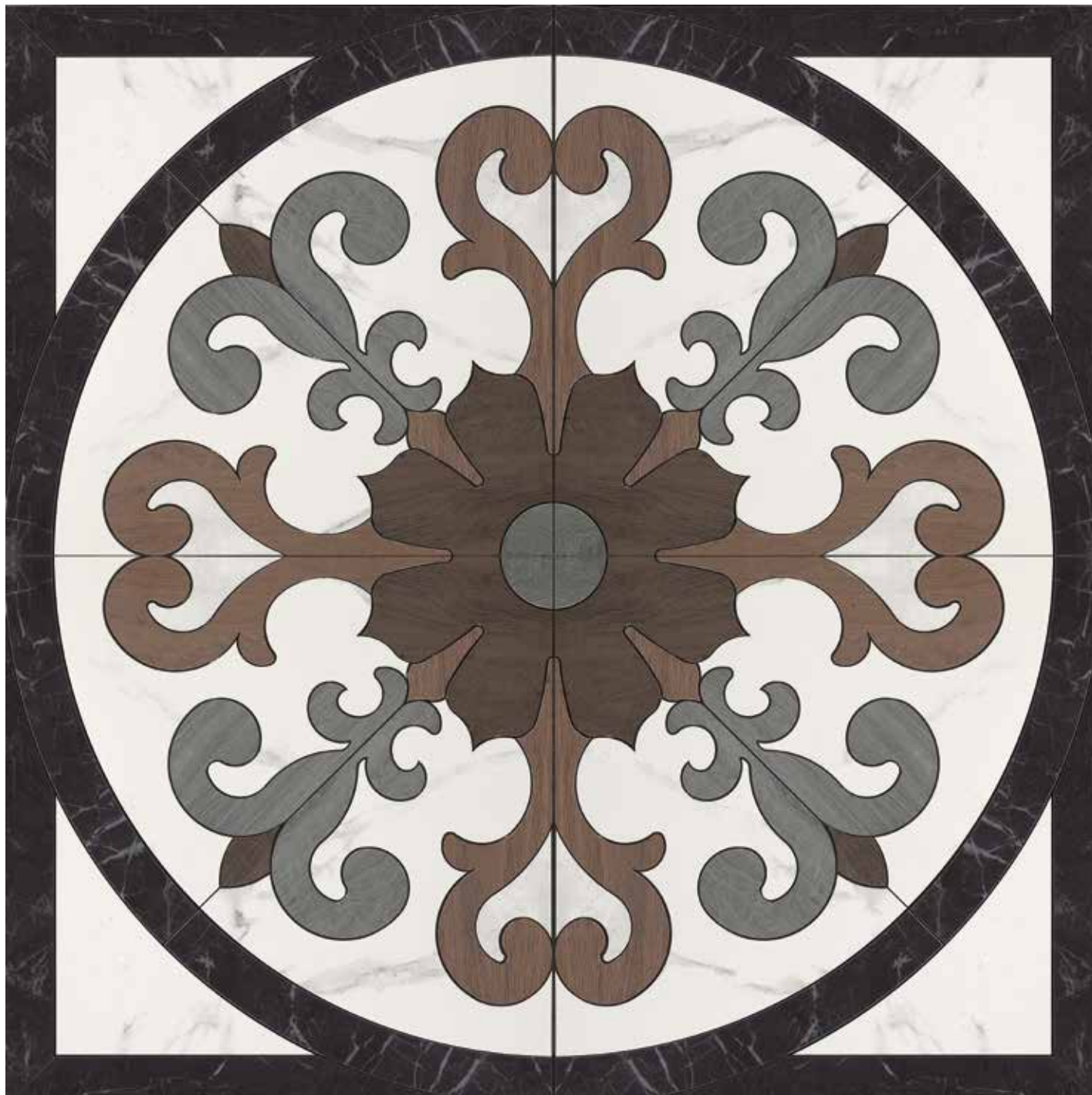

cm 118x118 - 46¹/₂"x46¹/₂"

statuario grigio, nero creta, tavolato antracite, tavolato marrone medio, tavolato marrone scuro

Solo superficie lucida. Lucida surface only. Seulement surface lucida. Nur in lucida Oberfläche.

marmoker

GRANITOKER

clessidra*



cm 59x118 - 23¹/₄"x 46¹/₂"

Solo superficie lucida Lucida surface only
Seulement surface lucida Nur in lucida Oberfläche

esagono**



cm 30x51,9 - 11³/₄"x 20³/₈"

Solo superficie lucida Lucida surface only
Seulement surface lucida Nur in lucida Oberfläche

esagoni**



cm 21,5x25 - 8¹/₂"x 9⁷/₈"
su rete on net sur trame auf Netz

Solo superficie lucida
Lucida surface only
Seulement surface lucida
Nur in lucida Oberfläche

esagoni 3D***

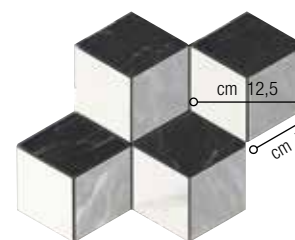

cm 21,5x25 - 8¹/₂"x 9⁷/₈"
su rete on net sur trame auf Netz

Solo superficie lucida
Lucida surface only
Seulement surface lucida
Nur in lucida Oberfläche

* Disponibile nei colori: Available in the colours: Disponible dans les couleurs: Verfügbar in den folgenden Farben: **bardiglio imperiale, breccia argento, saint laurent**

** Disponibile nei colori: Available in the colours: Disponible dans les couleurs: Verfügbar in den folgenden Farben: **asiago, bardiglio bianco, birimbau, bardiglio imperiale, breccia argento, canova, crema select, giallo striato, nero creta, olimpo, pulpis tortora, rosato, saint laurent, statuario grigio, statuario oro, zebrino**

*** Disponibile nei colori: Available in the colours: Disponible dans les couleurs: Verfügbar in den folgenden Farben: **bardiglio imperiale, nero creta, statuario grigio**

DECORI DECORS DÉCORS DEKORE

golden paint

Decoro abbinabile con
le collezioni Pietre di Paragone,
Pietre di Sardegna e Marmoker
Decor matching the Pietre di
Paragone, Pietre di Sardegna
and Marmoker collections
Décor pouvant être associé aux
collections Pietre di Paragone,
Pietre di Sardegna et Marmoker
Dekor kombinierbar mit den
Kollektionen Pietre di Paragone,
Pietre di Sardegna und Marmoker



cm 120x240 47¹/₄"x 94¹/₂"

marmoker

GRANITOKER

golden paint cm 120x240 - 47¹/₄"x94¹/₂"

MARMOKER

MARTE

ONICI

marte

GRANITOGRES



thassos cm 60x120 - 23⁵/₈"x47¹/₄"

COLORI COLOURS COULEURS FARBEN

nero acapulco



grigio maglia



grigio marostica



emperador



ramora brown



bronzetto

marte

GRANITOGRES

raggio di luna



grigio egeo



thassos



crema marfil



palissandro



botticino

COLORI COLOURS COULEURS FARBEN

azul bahia



azul macauba



verde guatemala



madras pink



rosa portogallo

SUPERFICI SURFACES SURFACES OBERFLÄCHEN

marte

GRANITOGRES











levigata
polished
polie
poliert









satinata
satin finished
satinée
satinert

naturale matt
naturelle matt
R9 A

bocciardata
bouchardée
gehämmert
R11 A+B

FORMATI SIZES FORMATS FORMATE

					
Formati Sizes Formats Formate	cm 15x15 5 ⁷ / ₈ "x5 ⁷ / ₈ "	cm 30x30 11 ³ / ₄ "x11 ³ / ₄ "	cm 40x40 15 ³ / ₄ "x15 ³ / ₄ "	cm 10x60 4"x23 ⁵ / ₈ "	cm 15x60 5 ⁷ / ₈ "x23 ⁵ / ₈ "
Superfici Surfaces Surfaces Oberflächen					
	mm 9,4	mm 9,4	mm 9,4	mm 9,4	mm 9,4

				
Formati Sizes Formats Formate	cm 30x60 11 ³ / ₄ "x23 ⁵ / ₈ "	cm 60x60 23 ⁵ / ₈ "x23 ⁵ / ₈ "	cm 20x120 7 ⁷ / ₈ "x47 ¹ / ₄ "	cm 60x120 23 ⁵ / ₈ "x47 ¹ / ₄ "
Superfici Surfaces Surfaces Oberflächen				
	mm 9,4	mm 10,5	mm 10,5	mm 10,5

* Spessore su superficie naturale e satinata Thickness on matt and satined surface
épaisseur sur surface mat et satinée Stärke der Fliesen mit Matt - satinierten Oberfläche

Rettificata in un unico calibro Rectified version in a single caliber Rectifiés en un unique calibre Boden Sie in einem einzigen Kaliber

-  Naturale Matt Naturelle Matt **R9 A**
(A richiesta On request
Sur demande Auf Anfrage **R10**)
-  Levigata Polished Polie Poliert
-  Satinata Satin Finished Satinée Satiniert
-  Bocciardata **R11 A+B**

Su richiesta possono essere forniti i formati ottenibili per taglio e/o gli spessori 12,3 mm e 14,2 mm.

Per poter uniformare gli spessori, specificare al momento dell'ordine una eventuale posa in opera combinata di formati diversi

On request we can supply the sizes obtained by cutting and/or the thicknesses both 12,3 mm and 14,2 mm.

In order to standardize the thickness, please specify when ordering an eventual installation combining different sizes

Sur demande peuvent être fournis : les formats obtenus par découpe et/ou les épaisseurs 12,3 mm et 14,2 mm.

Afin d'uniformiser les épaisseurs, veuillez préciser au moment de la commande si vous effectuez une pose combinée de formats différentes

Auf Anfrage können sowohl die Formaten geschnitten als auch die Stärke 12,3mm und 14,2mm geliefert werden um die Fliesenstärken

aneinander anpassen zu können, bitte bei der Bestellung angeben, dass Fliesen mit verschiedenen Formate zusammen verlegt werden sollen

PEZZI SPECIALI TRIMS ACCESSOIRES FORMSTÜCKE

marte

GRANITOGRES

Battiscopa Bullnose
Plinthe à bord arrondi Stehsockel
 cm 9x30 - 3 1/2"x11 3/4"
 cm 9x40 - 3 1/2"x15 3/4"
 cm 9x60 - 3 1/2"x23 5/8"



Zoccolo a raccordo a becco civetta*
Cove base with rounded edge*
Plinthe à gorge bord arrondi*
Hohlkehlsoclel mit abgerundeter Kante*
 cm 15x30 - 5 7/8"x11 3/4"

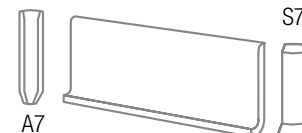

Gradino Step tread
Nez de marche Stufenplatte
 cm 30x30 - 11 3/4"x11 3/4"
 cm 30x60 - 11 3/4"x23 5/8"

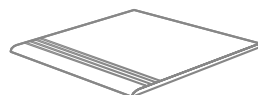

Listello Listel
Listel Zeierleiste
 cm 9x30 - 3 1/2"x11 3/4"
 cm 9x40 - 3 1/2"x15 3/4"
 cm 9x60 - 3 1/2"x23 5/8"



Gradone toro con bordo antiscivolo
Gradone toro with non-slip edge
Gradone toro avec nez antidérapant
Gradone toro mit rutschsicherer Kante
 cm 60x33 - 23 5/8"x13"

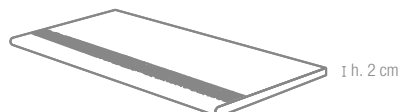

Angolare toro con bordo antiscivolo
Angolare toro with non-slip edge
Angolare toro avec nez antidérapant
Angolare toro mit rutschsicherer Kante
 cm 60x33 - 23 5/8"x13"

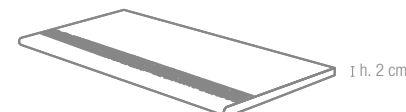

Gradone toro
 cm 60x33 - 23 5/8"x13"
 cm 120x33 - 47 1/4"x13"



Angolare toro
 cm 60x33 - 23 5/8"x13"
 cm 120x33 - 47 1/4"x13"

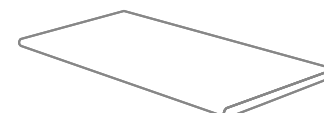

Gradone (assemblato)
 cm 30x33 - 11 3/4"x13"
 cm 60x33 - 23 5/8"x13"

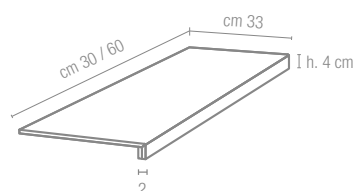

Angolare (assemblato)
 cm 30x33 - 11 3/4"x13"
 cm 60x33 - 23 5/8"x13"

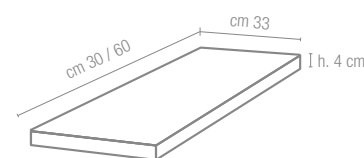

Scalino
 cm 40x33 - 15 3/4"x13"

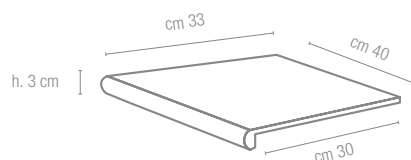

Scalino angolare
 cm 40x33 - 15 3/4"x13"

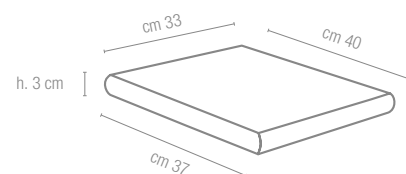

Battiscala DX**
 cm 39x27 - 15 3/8"x10 5/8"



Battiscala SX**
 cm 39x27 - 15 3/8"x10 5/8"

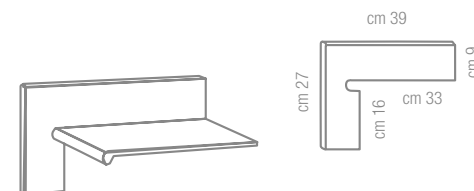

* Non rettificato Not rectified Non rectifié Nicht rektifiziert
 Produzione corente solo nei colori: Currently produced only in the following colours: Productions courantes seulement dans les couleurs: Aktuelle Produktion nur in den Farben:
Botticino, Bronzetto, Grigio Egeo, Nero Acapulco, Palissandro, Raggio di Luna, Thassos
 Altri colori a richiesta Other colours available on request Autres couleurs sur demande Weitere Farben auf Wunsch

** Solo su ordinazione. Attenzione! Specificare nell'ordine se il battiscala deve essere abbinato a scalino (h. 3 cm) o a gradone toro (h. 2 cm)
 Only on request. Important! The order must specify whether the battiscala must match a scalino (3 cm h.) or a gradone toro (2 cm h.)
 Seulement sur commande. Attention! Spécifier dans la commande si le battiscala doit être assorti au scalino (h. 3cm) ou au gradone toro (h. 2 cm)
 Nur auf Bestellung. Achtung! Beim Auftrag ist es zu vermerken, ob die Stufensockel (battiscala) zusammen mit dem scalino (3 cm hoch) bzw. Dem gradone toro (2 cm hoch) zu kombinieren sin

DECORI DECORS DÉCORS DEKORE

mosaico fresato*



cm 30x30 - 11³/₄"x11³/₄"
 tessera **cm 3x3** - 1¹/₈"x1¹/₈"
 su rete on net sur trame auf Netz

Superficie naturale e levigata Matt and polished surface
 Surface naturelle et polie Matte und polierte Oberfläche

mosaico*

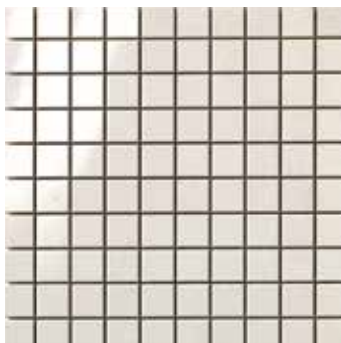

cm 30x30 - 11³/₄"x11³/₄"
 tessera **cm 3x3** - 1¹/₈"x1¹/₈"
 su rete on net sur trame auf Netz

Solo superficie levigata Polished surface only
 Seulement surface polie Nur in polierter Oberfläche

mosaico texture*

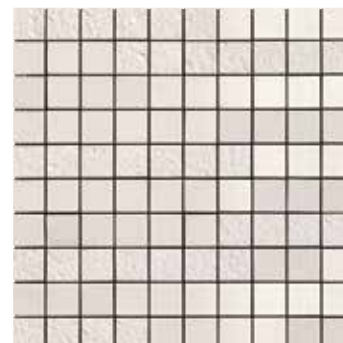

cm 30x30 - 11³/₄"x11³/₄"
 tessera **cm 3x3** - 1¹/₈"x1¹/₈"
 su rete on net sur trame auf Netz

Naturale, levigato, bocciardato Matt, polished, bocciardato
 Naturel, poli, bouchardé Matt, poliert, gehämmert

listelli*

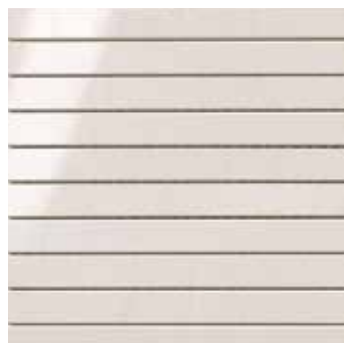

cm 30x30 - 11³/₄"x11³/₄"
 listello **cm 3x30** - 1¹/₈"x11³/₄"
 su rete on net sur trame auf Netz

Solo superficie levigata Polished surface only
 Seulement surface polie Nur in polierter Oberfläche

listelli texture*



cm 30x30 - 11³/₄"x11³/₄"
 listello **cm 1,5x30** - 5/8"x11³/₄"
 su rete on net sur trame auf Netz

Naturale, levigato, bocciardato Matt, polished, bocciardato
 Naturel, poli, bouchardé Matt, poliert, gehämmert

* Disponibile in tutti i colori della serie Available in all the colours of the series Disponible dans tous les couleurs e la série Verfügbar in allen Farben

marte

GRANITOGRES



listelli texture thassos cm 30x30 - 11³/₄"x11³/₄"
thassos cm 60x120 - 23⁵/₈"x47¹/₄"



DECORI DECORS DÉCORS DEKORE

mosaico mix A*



cm 30x30 - 11³/₄"x11³/₄"
 tessera **cm 2,2x2,2** - 7/₈"x7/₈"
su rete on net sur trame auf Netz

bianco assoluto, azul bahia,
 azul macauba

mosaico mix B*



cm 30x30 - 11³/₄"x11³/₄"
 tessera **cm 3x3** - 1¹/₈"x1¹/₈"
su rete on net sur trame auf Netz

bianco assoluto, azul bahia,
 azul macauba, acciaio

mosaico mix C*



cm 30x30 - 11³/₄"x11³/₄"
 tessera **cm 3x3** - 1¹/₈"x1¹/₈"
su rete on net sur trame auf Netz

grigio egeo, grigio maglia,
 raggio di luna

mosaico mix D*



cm 30x30 - 11³/₄"x11³/₄"
 tessera **cm 3x3** - 1¹/₈"x1¹/₈"
su rete on net sur trame auf Netz

grigio egeo, grigio maglia,
 raggio di luna, acciaio

mosaico mix E*



cm 30x30 - 11³/₄"x11³/₄"
 tessera **cm 2,2x2,2** - 7/₈"x7/₈"
su rete on net sur trame auf Netz

bianco assoluto, azul bahia,
 azul macauba

mosaico mix F*



cm 30x30 - 11³/₄"x11³/₄"
 tessera **cm 3x3** - 1¹/₈"x1¹/₈"
su rete on net sur trame auf Netz

bianco assoluto, azul bahia,
 azul macauba, acciaio

marte

GRANITOGRES



mosaico texture thassos cm 30x30 - 11³/₄"x11³/₄"

DECORI DECORS DÉCORS DEKORE

decoro A*



cm 30x30 - $11\frac{3}{4}$ "x $11\frac{3}{4}$ "
 tessera **cm 3x7,5** - $1\frac{1}{8}$ "x3"
su rete on net sur trame auf Netz

 mm 10

decoro B*



cm 30x30 - $11\frac{3}{4}$ "x $11\frac{3}{4}$ "
 tessera **cm 7,15x15** - 3 "x $5\frac{7}{8}$ "
su rete on net sur trame auf Netz

 mm 10

listello strass thassos**



cm 4x60 - $1\frac{5}{8}$ "x $23\frac{5}{8}$ "

listello strass nero acapulco**



cm 4x60 - $1\frac{5}{8}$ "x $23\frac{5}{8}$ "

matita*



cm 1x30 - $\frac{3}{8}$ "x $11\frac{3}{4}$ "

superficie levigata polished surface
 surface polie polierter Oberfläche

decoro C*



cm 30x60 - $11\frac{3}{4}$ "x $23\frac{5}{8}$ "
 listello **cm 1,5x60** - $\frac{5}{8}$ "x $23\frac{5}{8}$ "
su rete on net sur trame auf Netz

decoro D*



cm 30x60 - $11\frac{3}{4}$ "x $23\frac{5}{8}$ "
 listello **cm 7,5x60** - 3 "x $23\frac{5}{8}$ "
su rete on net sur trame auf Netz

* Disponibile in tutti i colori della serie Available in all the colours of the series Disponible dans tous les couleurs e la série Verfügbar in allen Farben

** Produzione standard su superficie levigata Standard production with polished surface Production standard pour la surface polie Standardausführung in polierter Oberfläche

marte

GRANITOGRES

listello strass thassos cm 4x60 - 1⁵/₈"x23⁵/₈"
thassos cm 15x60 - 5⁷/₈"x23⁵/₈", cm 30x60 - 11³/₄"x23⁵/₈"

onici

GRANITOKER



onice miele cm 118x236 - 46¹/₂"x92⁷/₈", cm 118x118 - 92⁷/₈"x92⁷/₈"

COLORI COLOURS COULEURS FARBEN

onice striato



onice bianco



onice miele



onice avorio







onice ghiaccio







onice quarzo

FORMATI SIZES FORMATS FORMATE

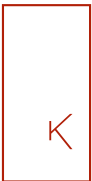
onici
GRANITOKER

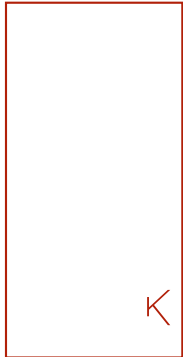
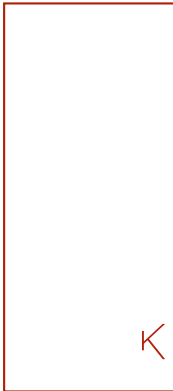
			
Formati Sizes Formats Formate	cm 59x59 23 ¹ / ₄ "x23 ¹ / ₄ "	cm 29,5x118 11 ⁵ / ₈ "x46 ¹ / ₂ "	cm 59x118 23 ¹ / ₄ "x46 ¹ / ₂ "
Superfici Surfaces Surfaces Oberflächen	● ●	● ●	● ●
	mm 10	mm 10	mm 10

				
Formati Sizes Formats Formate	cm 59x118 23 ¹ / ₄ "x46 ¹ / ₂ "	cm 118x118 46 ¹ / ₂ "x46 ¹ / ₂ "	cm 118x236 46 ¹ / ₂ "x92 ⁷ / ₈ "	cm 118x258 46 ¹ / ₂ "x101 ⁵ / ₈ "
Superfici Surfaces Surfaces Oberflächen	● ●	● ●	● ●	● ●
	mm 6,5	mm 6,5	mm 6,5	mm 6,5

K Lastre K_{ontinua}
K_{ontinua} Slabs
Dalles K_{ontinua}
K_{ontinua} Platten

Rettificate in un unico calibro Rectified version in a single caliber Rectifiés en un unique calibre Boden Sie in einem einzigen Kaliber

● Naturale Matt Naturelle Matt
● Lucida

Caratteristiche tecniche e imballi a pagina: Technical features and packing on page: Caractéristiques techniques et emballages à la page: Technische Eigenschaften und Verpackungen auf Seite: **501**

PEZZI SPECIALI TRIMS ACCESSOIRES FORMSTÜCKE

Battiscopa Bullnose
Plinthe à bord arrondi
Stehsockel
cm 9x59 - 3¹/₂"x23¹/₄"

● ●



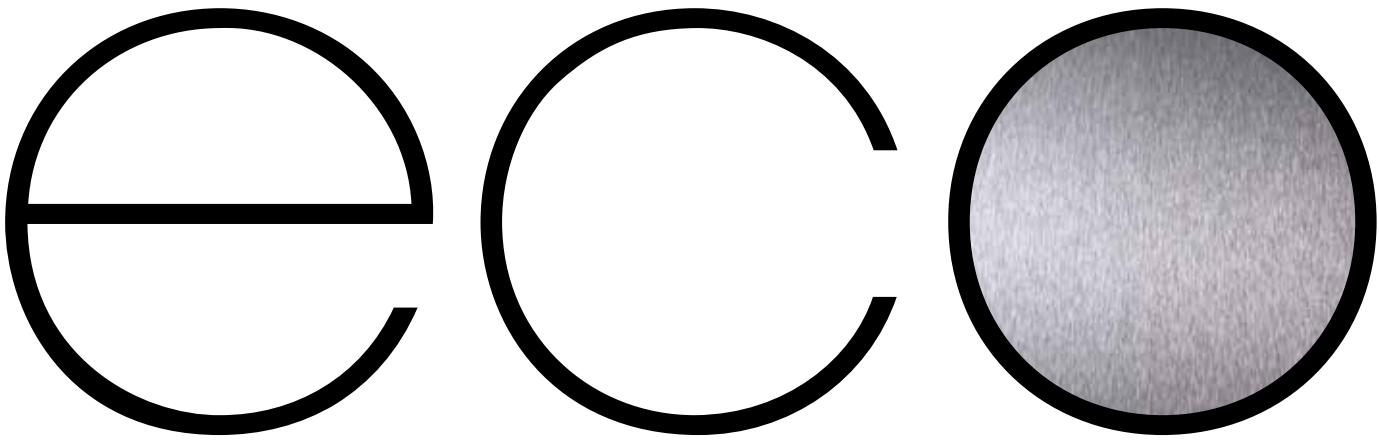

eco**metal** écom**étal** öko**metall**

metallo

eco**metallo**

230 **metallica**

236 **steeltech**

METALLO

Elemento chimico dotato di buona conducibilità termica ed elettrica, elevata tenacità, duttilità e malleabilità che lo qualificano come uno dei materiali maggiormente utilizzati a livello industriale. Caratterizzato dal potere riflettente e dall'opacità alla luce è in grado di formare con l'ossigeno ossidi a carattere più o meno spiccatamente basico.

METAL

A very strong, ductile and malleable chemical element with good thermal and electric conductivity that make it one of the most widely used materials for industrial applications. Standing out for its reflective power and opaqueness to light, it can bind to oxygen to form more or less alkaline oxides.

metallica

GRANITOKER



inox lappato cm 60x60 - 23⁵/₈"x23⁵/₈"

COLORI COLOURS COULEURS FARBEN

ferro lappato



inox lappato

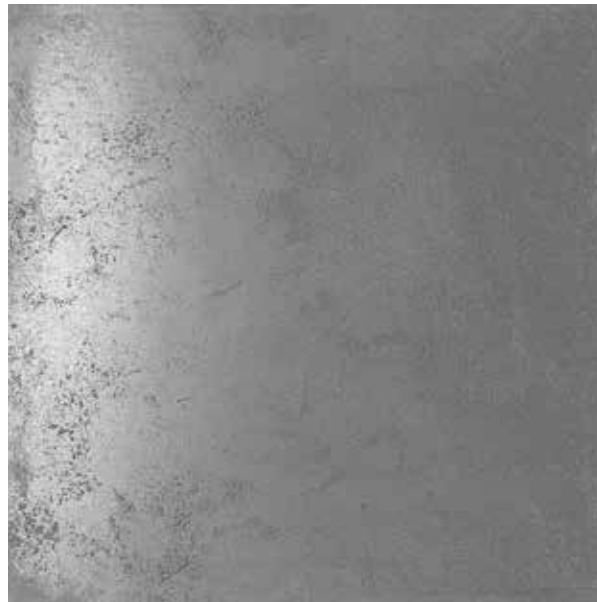

rame lappato



zinco-titanio lappato

SUPERFICI SURFACES SURFACES OBERFLÄCHEN





metallica

GRANITOKER

lappata

naturale matt
naturelle matt
R9

FORMATI SIZES FORMATS FORMATE

Formati Sizes Formats Formate		
	cm 30x60 11 ³ / ₄ "x23 ⁵ / ₈ "	cm 60x60 23 ⁵ / ₈ "x23 ⁵ / ₈ "
Superfici Surfaces Surfaces Oberflächen	●* ●	●* ●
	mm 10	mm 10
 Stonalizzazione media Shade variation medium Variations d'ombre moyenne Farbtonvarianten Mittel		● Naturale Matt Naturelle Matt R9 * Escluso Inox, Zinco-Titanio Inox, Zinco-Titanio excluded Exclus Inox, Zinco-Titanio Ausser Inox, Zinco-Titanio ● Lappata

Rettificate in un unico calibro Rectified version in a single caliber Rectifiés en un unique calibre Boden Sie in einem einzigen Kaliber

Caratteristiche tecniche e imballi a pagina: Technical features and packing on page: Caractéristiques techniques et emballages à la page: Technische Eigenschaften und Verpackungen auf Seite: **501**



rame lappato cm 60x60 - 23⁵/₈"x23⁵/₈"

PEZZI SPECIALI TRIMS ACCESSOIRES FORMSTÜCKE

Battiscopa Bullnose
Plinthe à bord arrondi
Stehsockel
cm 9x60 - 3¹/₂"x23⁵/₈"



Gradino Step tread
Nez de marche **Stufenplatte**
cm 30x60 - 11³/₄"x23⁵/₈"

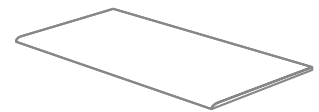

Gradone (assemblato)
cm 60x33 - 23⁵/₈"x13"

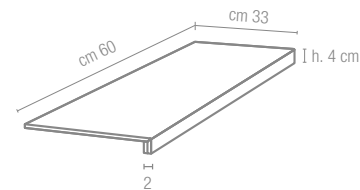

Angolare (assemblato)
cm 60x33 - 23⁵/₈"x13"

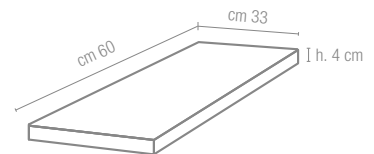

Gradino metal
cm 30x60 - 11³/₄"x23⁵/₈"



metallica

GRANITOKER

ferro lappato cm 60x60 - 23⁵/₈"x23⁵/₈"

DECORI DECORS DÉCORS DEKORE

decoro A*

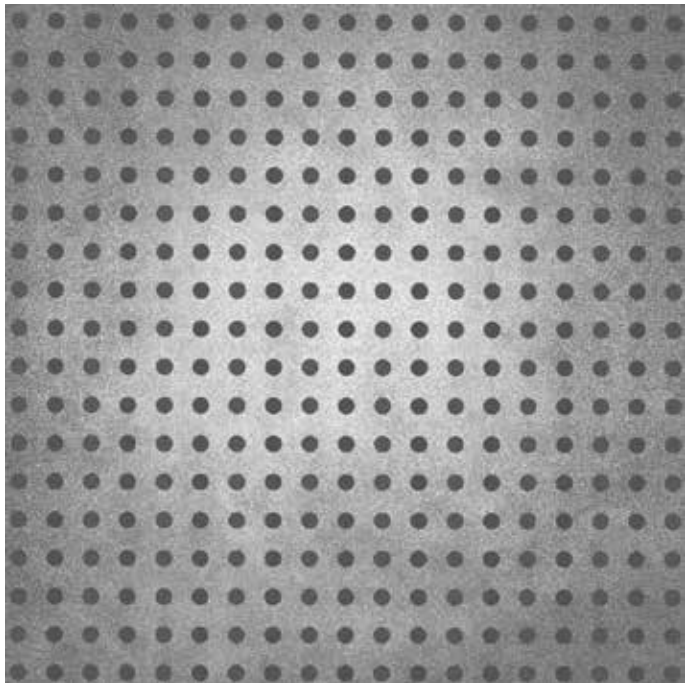
cm 60x60 - 23⁵/₈"x23⁵/₈"

decoro B*

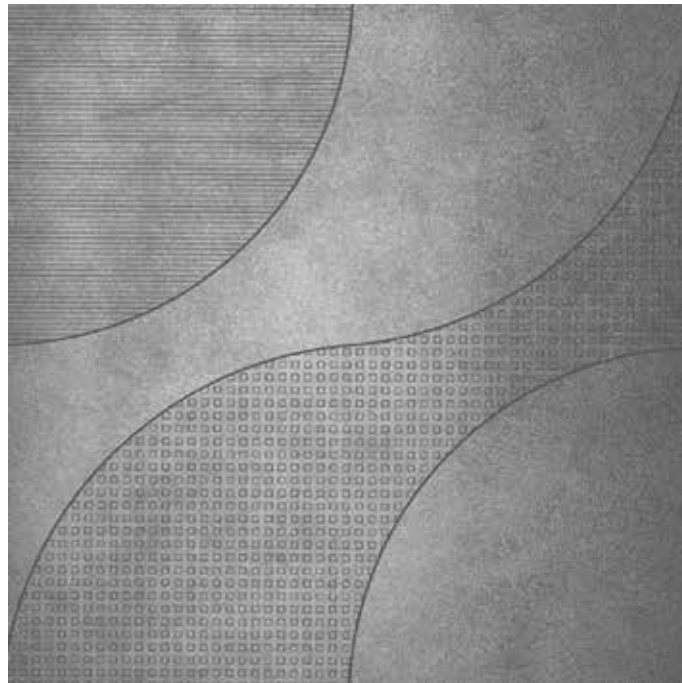
cm 60x60 - 23⁵/₈"x23⁵/₈"

mosaico ferro lappato

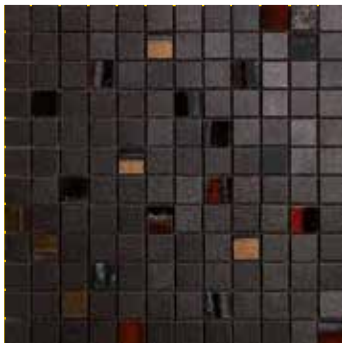

cm 30x30 - 11³/₄"x11³/₄"
 tessera cm 2,2x2,2- 2⁷/₈"x2⁷/₈"
 su rete on net sur trame auf Netz

mosaico inox lappato



cm 30x30 - 11³/₄"x11³/₄"
 tessera cm 2,2x2,2- 2⁷/₈"x2⁷/₈"
 su rete on net sur trame auf Netz

* Disponibile in tutti i colori della serie, superficie naturale e lappata Available in all the colours of the series, matt and "lappata" surface
 Disponible dans tous les couleurs de la série, surface naturelle et "lappata" Verfügbar in allen Farben, matt und "lappata" Oberfläche

metallica

GRANITOKER

ferro, zinco-titanio cm 60x60 - 23⁵/₈"x23⁵/₈", 30x60 - 11³/₄"x23⁵/₈"

steeltech

GRANITOKER



steeltech corten lappata, steeltech beige cm 90x90 - 35³/₈"x35³/₈"

COLORI COLOURS COULEURS FARBEN

steeltech antracite



steeltech corten



steeltech grigio



steeltech beige

SUPERFICI SURFACES SURFACES OBERFLÄCHEN















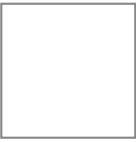



steeltech

GRANITOKER



lappata

naturale matt naturelle matt R9

FORMATI SIZES FORMATS FORMATE

Formati Sizes Formats Formate						
	cm 30x30 11 ³ / ₄ "x11 ³ / ₄ "	cm 30x60 11 ³ / ₄ "x23 ⁵ / ₈ "	cm 60x60 23 ⁵ / ₈ "x23 ⁵ / ₈ "	cm 45x90 17 ³ / ₄ "x35 ³ / ₈ "	cm 90x90 35 ³ / ₈ "x35 ³ / ₈ "	cm 60x120 23 ⁵ / ₈ "x47 ¹ / ₄ "
Superfici Surfaces Surfaces Oberflächen	 	 	 	 	 	 
	mm 10	mm 10	mm 10	mm 10	mm 10	mm 10

 Stonizzazione media
Shade variation medium
Variations d'ombre moyenne
Farbtonvarianten Mittel

 Naturale Matt Naturelle Matt **R9**
 Lappata

Rettificate in un unico calibro Rectified version in a single caliber Rectifiés en un unique calibre Boden Sie in einem einzigen Kaliber

Caratteristiche tecniche e imballi a pagina: Technical features and packing on page: Caractéristiques techniques et emballages à la page: Technische Eigenschaften und Verpackungen auf Seite: **501**



steeltech antracite cm 90x90 - 35³/₈"x35³/₄"

PEZZI SPECIALI TRIMS ACCESSOIRES FORMSTÜCKE

Battiscopa Bullnose
Plinthe à bord arrondi
Stehsockel
cm 9x60 - 3¹/₂"x23⁵/₈"
cm 9x90 - 3¹/₂"x35³/₈"



Gradino Step tread
Nez de marche Stufenplatte
cm 30x60 - 11³/₄"x23⁵/₈"
cm 30x90 - 11³/₄"x35³/₈"

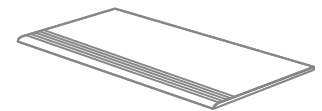

Gradone (assemblato)
cm 90x33 - 35³/₈"x13"

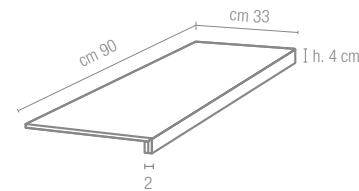

Angolare (assemblato)
cm 90x33 - 35³/₈"x13"

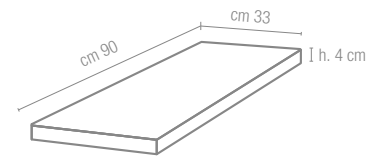

DECORI DECORS DÉCORS DEKORE

steeltech

GRANITOKER

decoro steeltech*

**cm 90x90** - $35\frac{3}{8}$ "x $35\frac{3}{8}$ "

Superficie naturale e lappata Matt and lappata surface
 Surface naturelle et lappata Matt und lappata Oberfläche

mosaico 6x6*



cm 30x30 - $11\frac{3}{4}$ "x $11\frac{3}{4}$ "
 tessera **cm 6x6** - $2\frac{3}{8}$ "x $2\frac{3}{8}$ "
 su rete on net sur trame auf Netz

Superficie naturale e lappata
 Matt and lappata surface
 Surface naturelle et lappata
 Matt und lappata Oberfläche

* Disponibile in tutti i colori della serie Available in all the colours of the series Disponible dans tous les couleurs de la série Verfügbar in allen farben

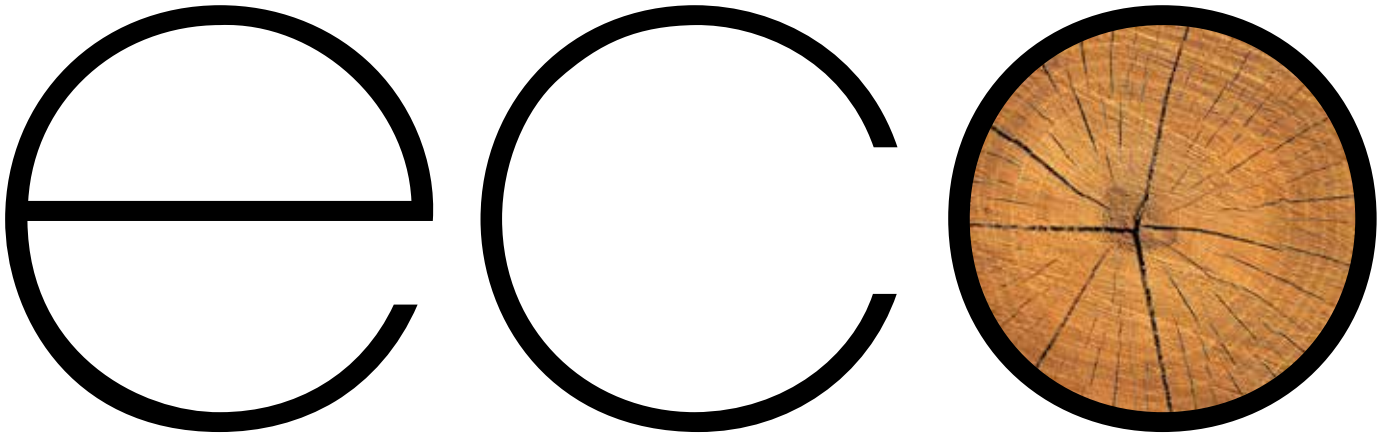

ecowood éco bois ökoholz

legno

ecolegno

- 248 **antique wood**
- 254 **country wood**
- 260 **class wood**
- 264 **geowood**
- 268 **tavolato**
- 274 **planks**
- 278 **limpha**
- 284 **ulivo**
- 290 **newood**
- 298 **metalwood**
- 304 **parchi**

LEGNO

Insieme dei tessuti vegetali [xilema] che formano la parte solida del fusto, dei rami e delle radici degli alberi. La parte più vecchia e più interna del tronco è detta durame, la parte più giovane e periferica alburo. Il legno sin dall'antichità ha trovato notevoli applicazioni nella produzione della carta, nell'edilizia, nell'industria manifatturiera.

WOOD

The group of vegetable tissues [xylem] that form the solid part of the tree trunk, branches and roots. The oldest and innermost part of the trunk is also known as hardwood, while the youngest and outermost part of the trunk is known as sapwood. Since antiquity, wood has been widely used to make paper, in the building and manufacturing industries, in design.

antique wood antique black

antique wood

GRANITOKER



antique black cm 20x120 - 77/8"x47 1/4"

COLORI COLOURS COULEURS FARBEN

antique black



antique moka





antique white



FORMATI SIZES FORMATS FORMATE

antique wood

GRANITOKER

Formati Sizes Formats Formate	 cm 15x120 5 ⁷ / ₈ "x47 ¹ / ₄ "	 cm 20x120 7 ⁷ / ₈ "x47 ¹ / ₄ "
Superfici Surfaces Surfaces Oberflächen	●	●
	mm 10	mm 10



Stonizzazione accentuata
Shade variation accentuated
Variations d'ombre Forte
Farbtonvarianten Akzentuiert

● Naturale Matt Naturelle Matt **R10 A+B**

Rettificate in un unico calibro Rectified version in a single caliber Rectifiés en un unique calibre Boden Sie in einem einzigen Kaliber

Caratteristiche tecniche e imballi a pagina: Technical features and packing on page: Caractéristiques techniques et emballages à la page: Technische Eigenschaften und Verpackungen auf Seite: **501**

PEZZI SPECIALI TRIMS ACCESSOIRES FORMSTÜCKE

Battiscopa Bullnose
Plinthe à bord arrondi
Stehsockel
cm 9x120 - 3¹/₂"x47¹/₄"



Gradino Step tread
Nez de marche Stufenplatte
cm 30x120 - 11³/₄"x47¹/₄"

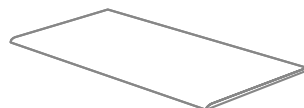

Gradone (assemblato)
cm 120x33 - 47¹/₄"x13"

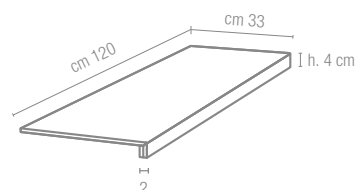

Angolare (assemblato)
cm 120x33 - 47¹/₄"x13"

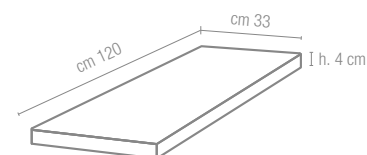

listone antique white
cm 20x120 - 7⁷/₈"x47¹/₄"
antique white cm 20x120 - 7⁷/₈"x47¹/₄"

DECORI DECORS DÉCORS DEKORE

listone antique*



cm 20x120 - 7⁷/₈"x47¹/₄"

listelli antique*



cm 30x30 - 11³/₄"x11³/₄"
listello cm 1,4x30 - 1/2"x11³/₄"
su rete on net sur trame auf Netz

chevron A*

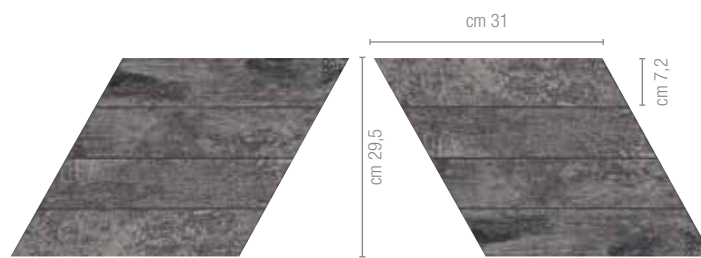

cm 31x29,5 - 12¹/₄"x11⁵/₈" dx / sx
su rete on net sur trame auf Netz

chevron B*

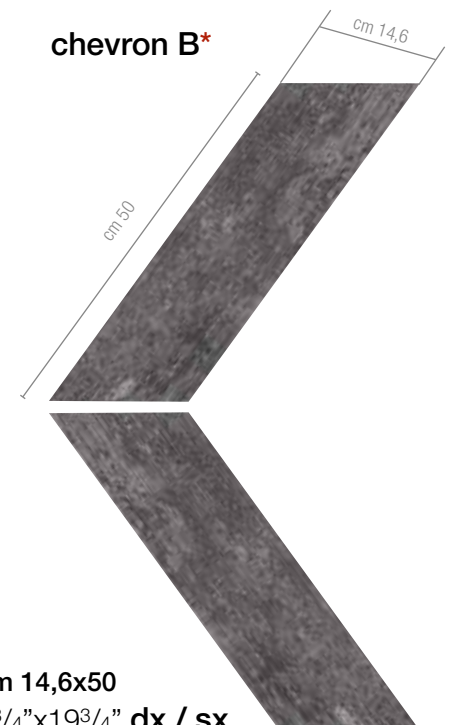

cm 14,6x50
5³/₄"x19³/₄" dx / sx

* Disponibile in tutti i colori della serie Available in all the colours of the series
Disponibile dans tous les couleurs e la série Verfügar in allen farben

antique wood

GRANITOKER

chevron A antique black cm 31x29,5 - 12¹/₄"x11⁵/₈"

country wood

GRANITOKER



country greige cm 20x120 - 7⁷/₈"x47¹/₄"

COLORI COLOURS COULEURS FARBEN

country tortora



country marrone



country greige



country bianco











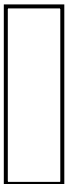

country ice



FORMATI SIZES FORMATS FORMATE

country wood

GRANITOKER

			
Formati Sizes Formats Formate	cm 40x120 15 ³ / ₄ "x47 ¹ / ₄ "	cm 20x120 7 ⁷ / ₈ "x47 ¹ / ₄ "	cm 25x151 9 ⁷ / ₈ "x59 ¹ / ₂ "
Superfici Surfaces Surfaces Oberflächen			
	mm 20	mm 10	mm 10
 Stonalizzazione accentuata Shade variation accentuated Variations d'ombre Forte Farbtonvarianten Akzentuiert			 Naturale Matt Naturelle Matt R10  Grip R11 A+B

Rettificate in un unico calibro Rectified version in a single caliber Rectifiés en un unique calibre Boden Sie in einem einzigen Kaliber

Caratteristiche tecniche e imballi a pagina: Technical features and packing on page: Caractéristiques techniques et emballages à la page: Technische Eigenschaften und Verpackungen auf Seite: **501**

PEZZI SPECIALI TRIMS ACCESSOIRES FORMSTÜCKE

▲ 2pcs  45°

Battiscopa Bullnose
Plinthe à bord arrondi
Stehsockel
cm 9x120 - 3¹/₂"x47¹/₄"



Gradino Step tread
Nez de marche Stufenplatte
cm 30x120 - 11³/₄"x47¹/₄"

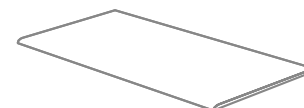

Art. 9678 Bordo angolare interno ▲
cm 33x60x2 - 13"x23⁵/₈"x3³/₄"

Art. 9688 Bordo angolare interno ▲
cm 20x60x2 - 7⁷/₈"x23⁵/₈"x3³/₄"

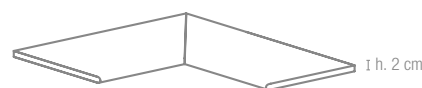

Art. 9677 Bordo angolare esterno ▲
cm 33x120 - 13"x47¹/₄"

Art. 9687 Bordo angolare esterno ▲
cm 20x60 - 7⁷/₈"x23⁵/₈"



Art. 9670 Bordo
cm 33x120 - 13"x47¹/₄"

Art. 9680 Bordo
cm 20x120 - 7⁷/₈"x47¹/₄"



Art. 9883 Griglia
cm 30x40x2 - 11³/₄"x15³/₄" x3³/₄"

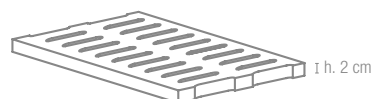

Art. 9884 Griglia angolare ▲
cm 30x40 - 11³/₄"x15³/₄"



Art. 9685 Griglia
cm 13x40 - 5¹/₈"x15³/₄"

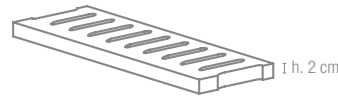

Art. 9686 Griglia angolare ▲
cm 13x40 - 5¹/₈"x15³/₄"

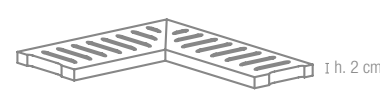

DECORI DECORS DÉCORS DEKORE

chevron A*



cm 31x29,5 - 12¹/₄"x11⁵/₈" dx / sx
su rete on net sur trame auf Netz

chevron B*



cm 14,6x50
5³/₄"x19³/₄" dx / sx

* Disponibile in tutti i colori della serie Available in all the colours of the series
 Disponible dans tous les couleurs e la série Verfügar in allen farben



country marrone cm 20x120 - 7⁷/₈"x47¹/₄",
cm 25x151 - 9⁷/₈"x59¹/₂"

country wood

GRANITOKER



country tortora chevron B cm 14,6x50 - 5³/₄"x19³/₄"

class wood

GRANITOKER



class grey cm 20x120 - 77/8"x47 1/4"

COLORI COLOURS COULEURS FARBEN

class walnut



class brown



class grey





class dove grey



FORMATI SIZES FORMATS FORMATE

class wood

GRANITOKER

		
Formati Sizes Formats Formate	cm 20x120 7 ⁷ / ₈ "x47 ¹ / ₄ "	cm 22,5x180 8 ⁷ / ₈ "x70 ⁷ / ₈ "
Superfici Surfaces Surfaces Oberflächen	●	●
	mm 10	mm 10



Stonizzazione media
Shade variation medium
Variations d'ombre moyenne
Farbtonvarianten Mittel

● Naturale Matt Naturelle Matt **R10**

Rettificate in un unico calibro Rectified version in a single caliber Rectifiés en un unique calibre Boden Sie in einem einzigen Kaliber

Caratteristiche tecniche e imballi a pagina: Technical features and packing on page: Caractéristiques techniques et emballages à la page: Technische Eigenschaften und Verpackungen auf Seite: **501**

PEZZI SPECIALI TRIMS ACCESSOIRES FORMSTÜCKE

Battiscopa Bullnose
Plinthe à bord arrondi
Stehsockel
cm 9x120 - 3¹/₂"x47¹/₄"



Gradino Step tread
Nez de marche Stufenplatte
cm 30x120 - 11³/₄"x47¹/₄"

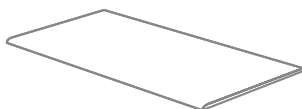

Gradone (assemblato)
cm 120x33 - 47¹/₄"x13"

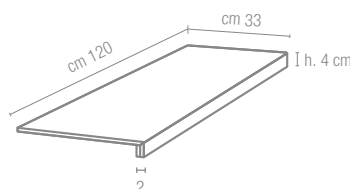

Angolare (assemblato)
cm 120x33 - 47¹/₄"x13"

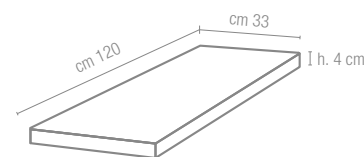

class brown cm 22,5x180 - 8⁷/₈"x47¹/₄"

geowood white oak

geowood

GRANITOKER



white oak cm 22,5x180 -8⁷/₈"x70⁷/₈"

COLORI COLOURS COULEURS FARBEN

koa



iroko



amazique



zebrawood



white oak



FORMATI SIZES FORMATS FORMATE

geowood

GRANITOKER



Formati Sizes
Formats Formate

cm 22,5x180
8⁷/₈"x70⁷/₈"

Superfici Surfaces
Surfaces Oberflächen



mm 10



Stonizzazione media
Shade variation medium
Variations d'ombre moyenne
Farbtonvarianten Mittel

● Naturale Matt Naturelle Matt **R9**
● Grip **R11**

PEZZI SPECIALI TRIMS
ACCESSOIRES FORMSTÜCKE

Battiscopa Bullnose
Plinthe à bord arrondi
Stehsockel
cm 9x180 - 3¹/₂"x70⁷/₈"



Rettificate in un unico calibro Rectified version in a single caliber Rectifiés en un unique calibre Boden Sie in einem einzigen Kaliber

Caratteristiche tecniche e imballi a pagina: Technical features and packing on page: Caractéristiques techniques et emballages à la page: Technische Eigenschaften und Verpackungen auf Seite: **501**

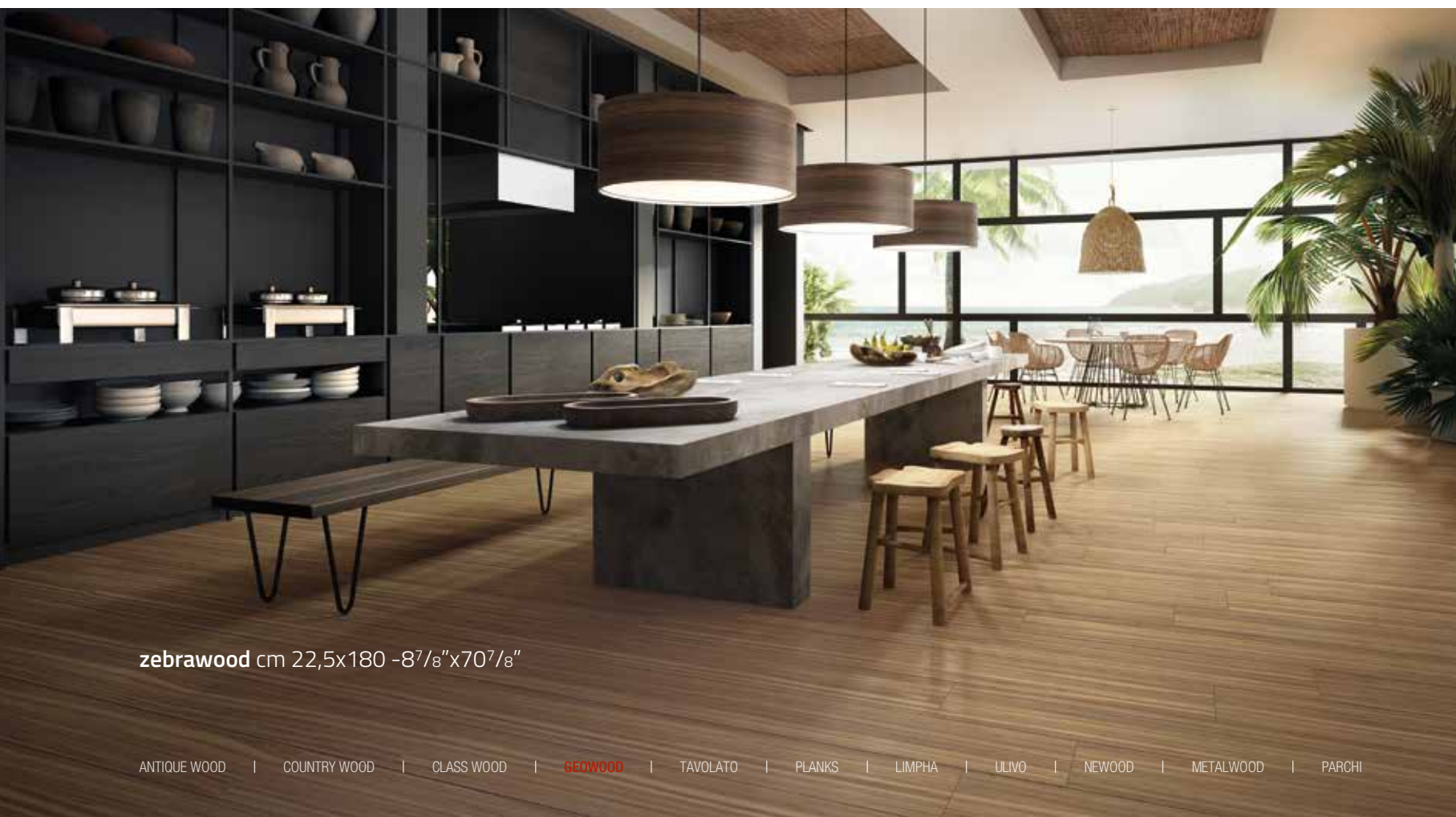

zebrawood cm 22,5x180 - 8⁷/₈"x70⁷/₈"

tavolato sbiancato

tavolato

GRANITOKER

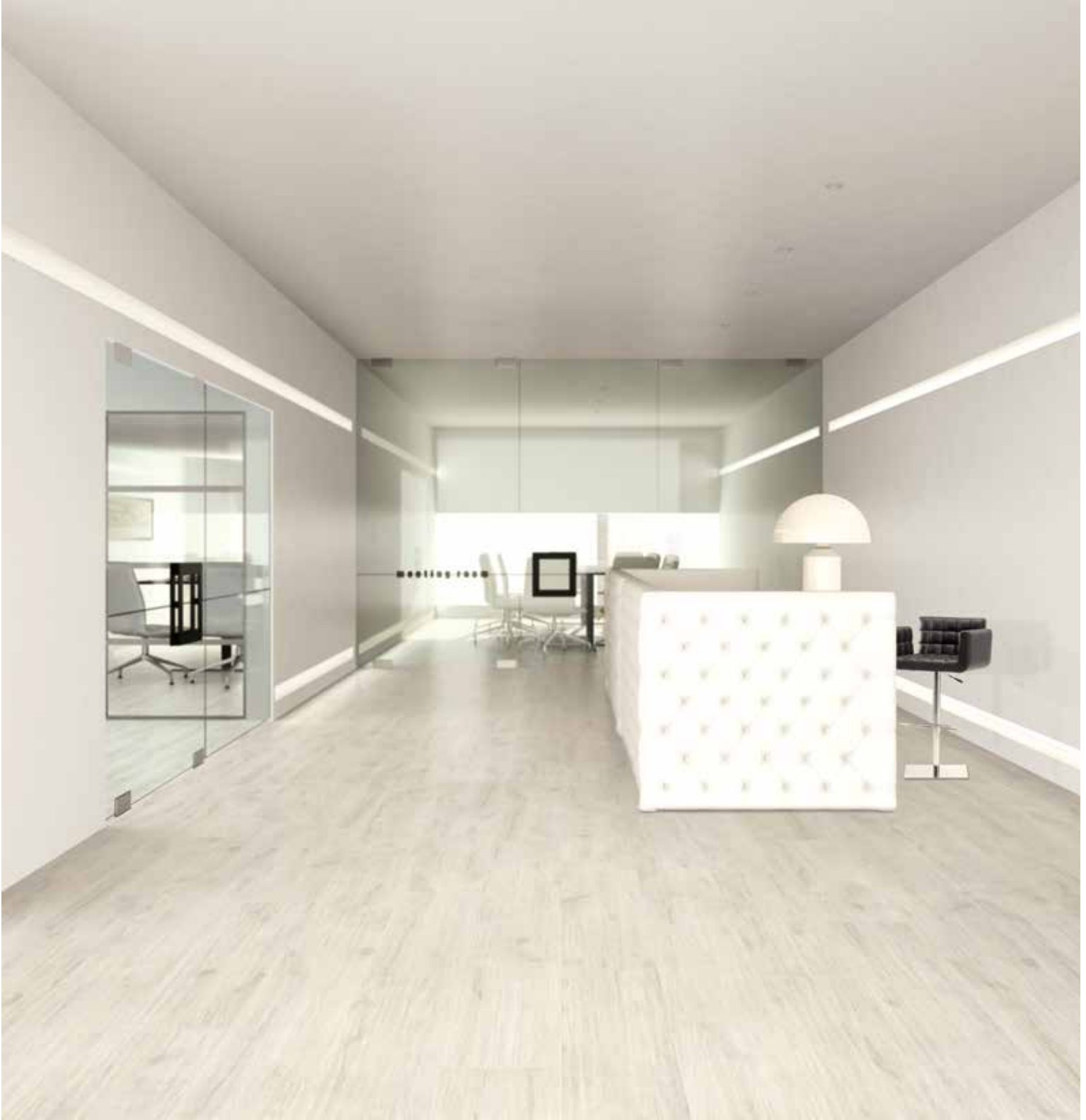

tavolato sbiancato cm 15x120 - 5⁷/₈"x47¹/₄", 20x120 - 7⁷/₈"x47¹/₄", 30x120 - 11³/₄"x47¹/₄"

COLORI COLOURS COULEURS FARBEN

**tavolato
antracite**



**tavolato
marrone scuro**



**tavolato
marrone medio**



**tavolato
marrone chiaro**



**tavolato
grano**



FORMATI SIZES FORMATS FORMATE

tavolato

GRANITOKER

tavolato
sbiancato



Formati Sizes Formats Formate	cm 15x60 5 ⁷ / ₈ "x23 ⁵ / ₈ "	cm 15x90 5 ⁷ / ₈ "x35 ³ / ₈ "	cm 15x120 5 ⁷ / ₈ "x47 ¹ / ₄ "	cm 20x120 7 ⁷ / ₈ "x47 ¹ / ₄ "	cm 30x120 11 ³ / ₄ "x47 ¹ / ₄ "
Superfici Surfaces Surfaces Oberflächen	●	●	●	●	●
	mm 8*	mm 8*	mm 10	mm 10	mm 10

Stonalizzazione accentuata
Shade variation accentuated
Variations d'ombre Forte
Farbtonvarianten Akzentuiert

● Naturale Matt Naturelle Matt **R9**

* Non rettificato Unrectified Non rectifié Nicht kalibriert

Rettificate in un unico calibro Rectified version in a single caliber Rectifiés en un unique calibre Boden Sie in einem einzigen Kaliber

Caratteristiche tecniche e imballi a pagina: Technical features and packing on page:

Caractéristiques techniques et emballages à la page: Technische Eigenschaften und Verpackungen auf Seite: **501**

PEZZI SPECIALI TRIMS ACCESSOIRES FORMSTÜCKE

Battiscopa Bullnose
Plinthe à bord arrondi
Stehsockel
cm 9x120 - 3¹/₂"x47¹/₄"
cm 7,5x60 - 3"x23⁵/₈"



Gradino Step tread
Nez de marche Stufenplatte
cm 30x120 - 11³/₄"x47¹/₄"

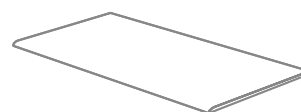

Gradone (assemblato)
cm 120x33 - 47¹/₄"x13"

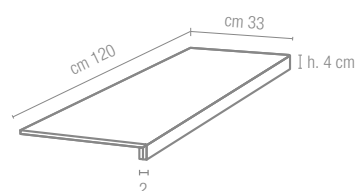

Angolare (assemblato)
cm 120x33 - 47¹/₄"x13"

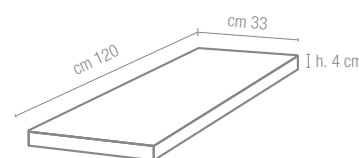

DECORI DECORS DÉCORS DEKORE

cassettone tavolato A*



cm 60x60 - 23⁵/₈"x23⁵/₈"

chevron A*



cm 31x29,5 - 12¹/₄"x11⁵/₈" dx / sx
su rete on net sur trame auf Netz

listelli tavolato*



cm 30x30 - 11³/₄"x11³/₄"
 listello cm 1,4x30 - 1/2"x11³/₄"
su rete on net sur trame auf Netz

quadrotte tavolato*



cm 30x30 - 11³/₄"x11³/₄"
su rete on net sur trame auf Netz

chevron B*

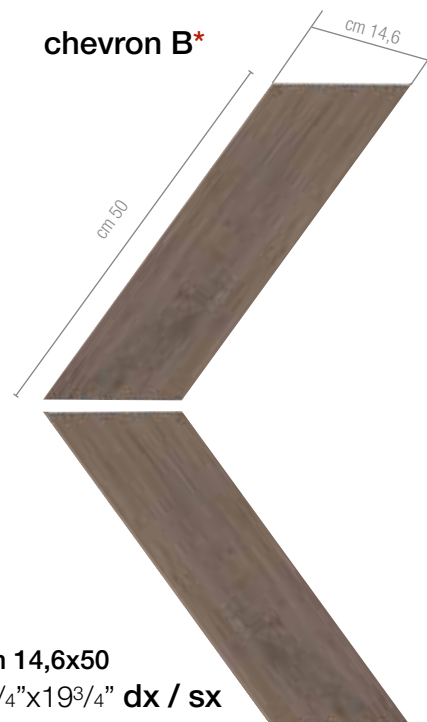

cm 14,6x50
 5³/₄"x19³/₄" dx / sx

* Disponibile in tutti i colori della serie Available in all the colours of the series
 Disponible dans tous les couleurs e la série Verfügar in allen farben

tavolato

GRANITOKER

cassettone tavolo A marrone scuro cm 60x60 - $23\frac{5}{8}'' \times 23\frac{5}{8}''$,
tavolato marrone scuro cm 15x120 - $5\frac{7}{8}'' \times 47\frac{1}{4}''$, cm 20x120 - $7\frac{7}{8}'' \times 47\frac{1}{4}''$, cm 30x120 - $11\frac{3}{4}'' \times 47\frac{1}{4}''$

planks

GRANITOKER



planks beige cm 20x240 - 7⁷/₈"x94¹/₂", cm 30x240 - 11³/₄"x94¹/₂"

COLORI COLOURS COULEURS FARBEN

planks grigio



planks bruno



planks muschio



planks bianco



planks beige









FORMATI SIZES FORMATS FORMATE

planks

GRANITOKER

K Lastre K_ontinua
K_ontinua Slabs
Dalles K_ontinua
K_ontinua Platten

				
Formati Sizes Formats Formate	cm 20x120 7 ⁷ / ₈ "x47 ¹ / ₄ "	cm 30x120 11 ³ / ₄ "x47 ¹ / ₄ "	cm 20x240 7 ⁷ / ₈ "x94 ¹ / ₂ "	cm 30x240 11 ³ / ₄ "x94 ¹ / ₂ "
Superfici Surfaces Surfaces Oberflächen	●	●	●	●
	mm 6,5	mm 6,5	mm 6,5	mm 6,5
 Stonalizzazione media Shade variation medium Variations d'ombre moyenne Farbtonvarianten Mittel				● Naturale Matt Naturelle Matt

Rettificate in un unico calibro Rectified version in a single caliber Rectifiés en un unique calibre Boden Sie in einem einzigen Kaliber

Caratteristiche tecniche e imballi a pagina: Technical features and packing on page: Caractéristiques techniques et emballages à la page: Technische Eigenschaften und Verpackungen auf Seite: **501**

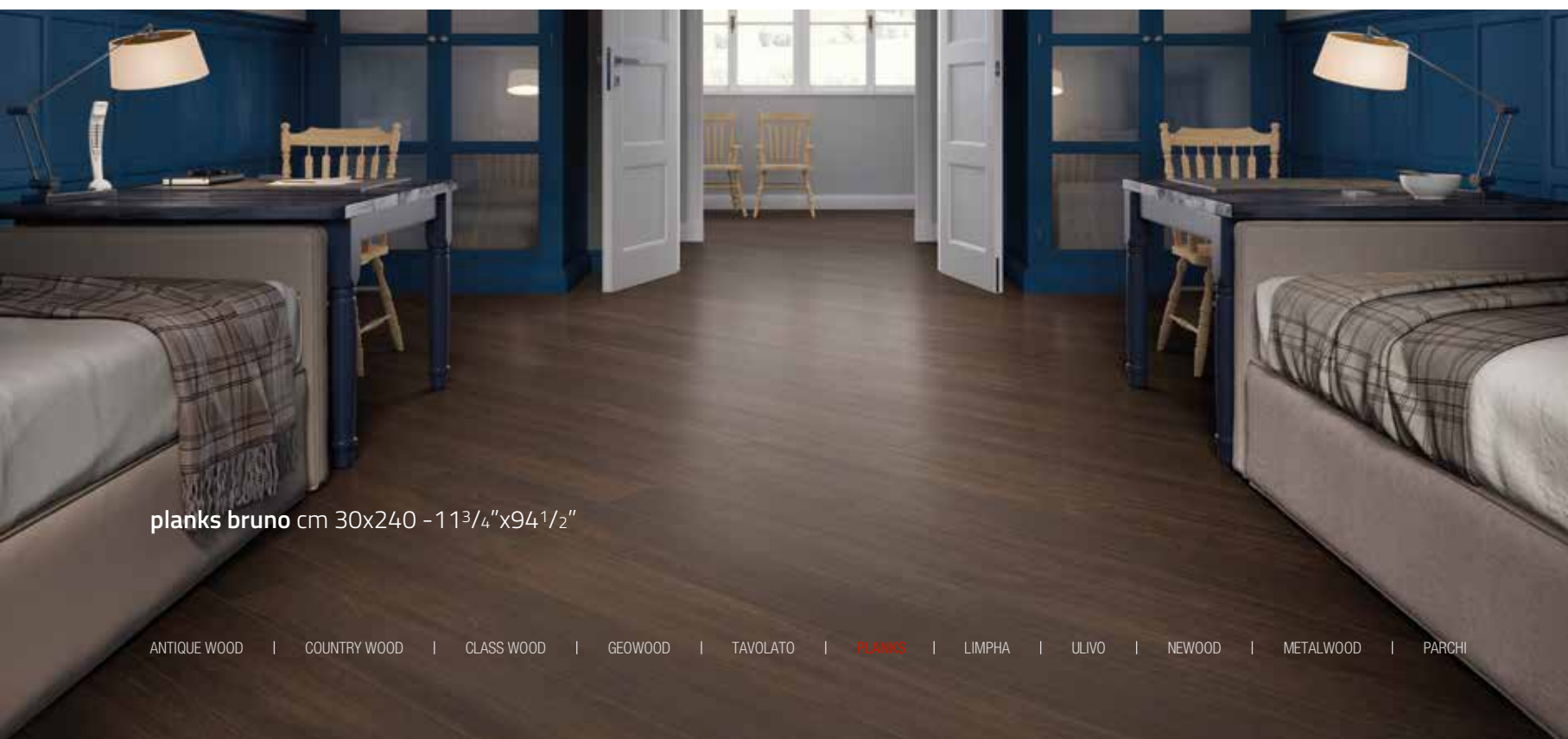

planks bruno cm 30x240 - 11³/₄"x94¹/₂"



limpha helix

limpha

GRANITOKER



helix cm 120x240 - 47 1/4"x94 1/2"

COLORI COLOURS COULEURS FARBEN

arborea



gelsomino



helix



FORMATI SIZES FORMATS FORMATE

limpha

GRANITOKER

K Lastre K_ontinua
 K_ontinua Slabs
 Dalles K_ontinua
 K_ontinua Platten

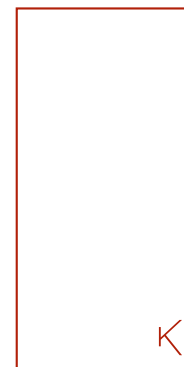

Formati Sizes
 Formats Formate

cm 120x240
 47 1/4" x 94 1/2"

Superfici Surfaces
 Surfaces Oberflächen



mm 6,5



Stonizzazione media
 Shade variation medium
 Variations d'ombre moyenne
 Farbtonvarianten Mittel

● Naturale Matt Naturelle Matt

Rettificate in un unico calibro Rectified version in a single caliber Rectifiés en un unique calibre Boden Sie in einem einzigen Kaliber

Caratteristiche tecniche e imballi a pagina: Technical features and packing on page: Caractéristiques techniques et emballages à la page: Technische Eigenschaften und Verpackungen auf Seite: **501**

Kontinua COMPOSIZIONE ENDMATCH

cm 120x240

limpha arborea

Rettificate in un unico calibro
Single caliber, rectified version
Rectifiés en un unique calibre
Einem einzigen Werkmass
maßgeschliffen geliefert

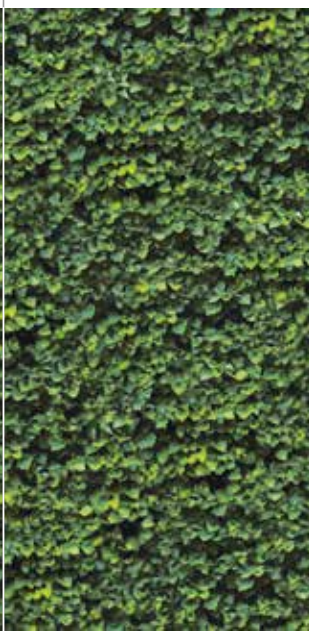
arborea **A**arborea **B**arborea **C**arborea **D**

limpha gelsomino

Rettificate in un unico calibro
Single caliber, rectified version
Rectifiés en un unique calibre
Einem einzigen Werkmass
maßgeschliffen geliefert

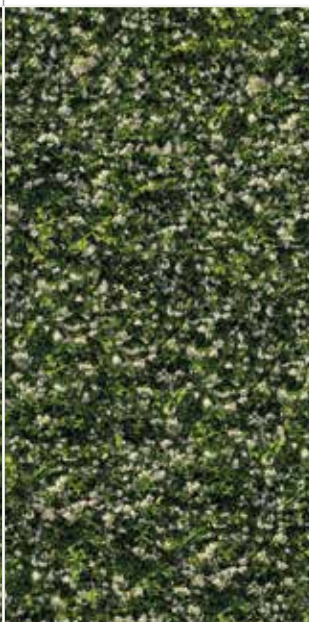
gelsomino **A**gelsomino **B**gelsomino **C**gelsomino **D**

limpha

GRANITOKER

limpha helix

Rettificate in un unico calibro
Single caliber, rectified version
Rectifiés en un unique calibre
Einem einzigen Werkmass
maßgeschliffen geliefert

helix **A**

helix **B**

helix **C**

helix **D**

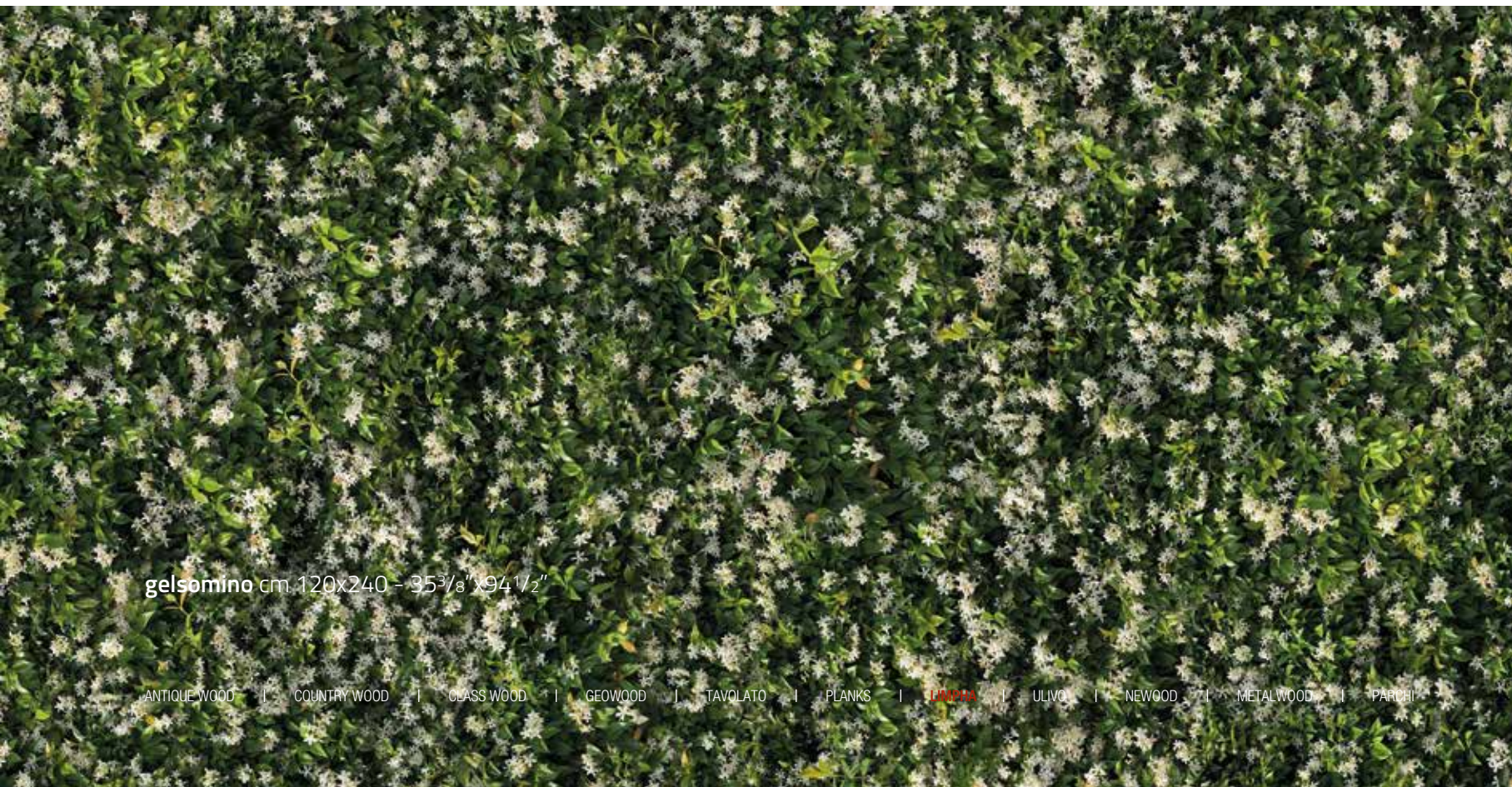
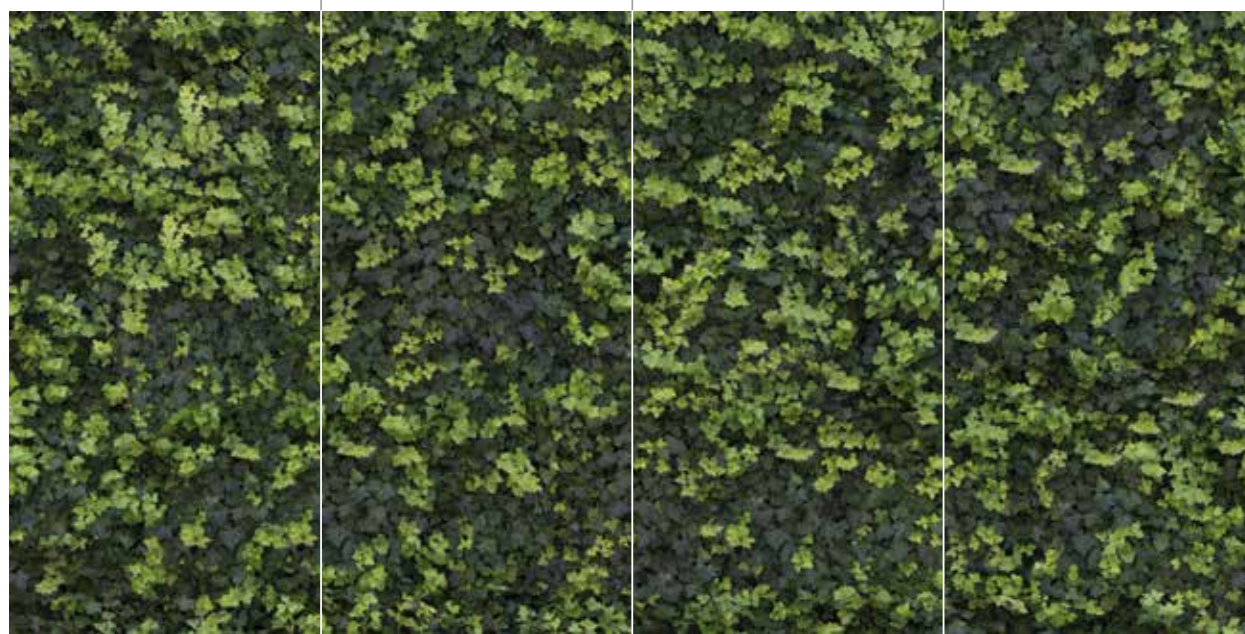

gelsomino cm. 120x240 - 35³/₈" x 94¹/₂"

ulivo

GRANITOKER



ulivo noce cm 15x120 - 5⁷/₈"x47¹/₄", 20x120 - 7⁷/₈"x47¹/₄", 30x120 - 11³/₄"x47¹/₄"

COLORI COLOURS COULEURS FARBEN

ulivo grigio

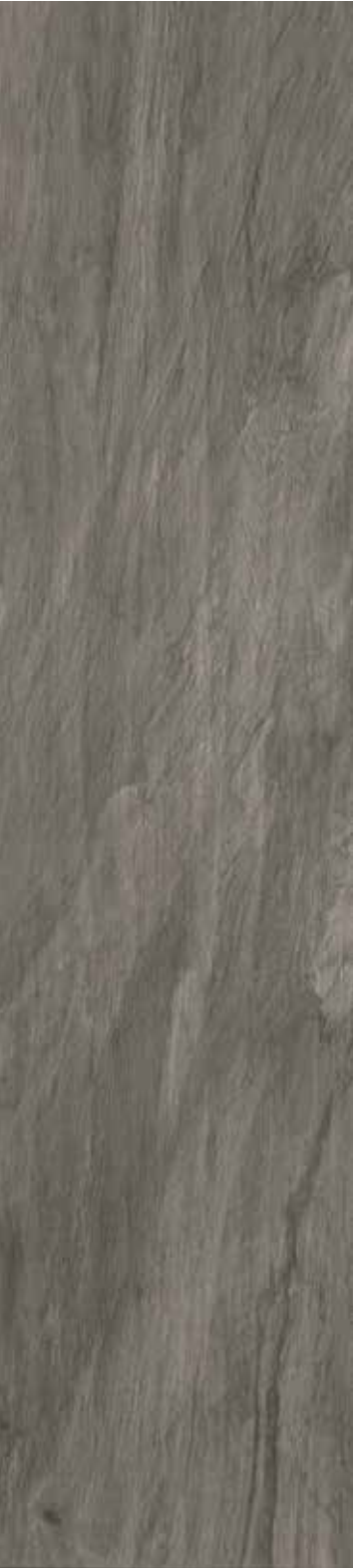

ulivo tortora



ulivo noce







ulivo panna



FORMATI SIZES FORMATS FORMATE

ulivo

GRANITOKER

			
Formati Sizes Formats Formate	cm 15x120 5 ⁷ / ₈ "x47 ¹ / ₄ "	cm 20x120 7 ⁷ / ₈ "x47 ¹ / ₄ "	cm 30x120 11 ³ / ₄ "x47 ¹ / ₄ "
Superfici Surfaces Surfaces Oberflächen	●	●	●
	mm 10	mm 10	mm 10
 Stonalizzazione accentuata Shade variation accentuated Variations d'ombre Forte Farbtonvarianten Akzentuiert			● Naturale Matt Naturelle Matt R10

Rettificate in un unico calibro Rectified version in a single caliber Rectifiés en un unique calibre Boden Sie in einem einzigen Kaliber

Caratteristiche tecniche e imballi a pagina: Technical features and packing on page: Caractéristiques techniques et emballages à la page: Technische Eigenschaften und Verpackungen auf Seite: **501**

PEZZI SPECIALI TRIMS ACCESSOIRES FORMSTÜCKE

Battiscopa Bullnose
Plinthe à bord arrondi
Stehsockel
cm 9x120 - 3¹/₂"x47¹/₄"



Gradino Step tread
Nez de marche Stufenplatte
cm 30x120 - 11³/₄"x47¹/₄"

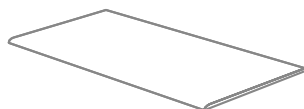

Gradone (assemblato)
cm 120x33 - 47¹/₄"x13"

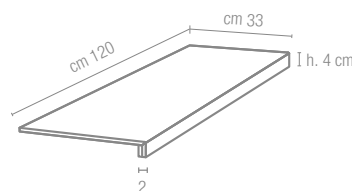

Angolare (assemblato)
cm 120x33 - 47¹/₄"x13"

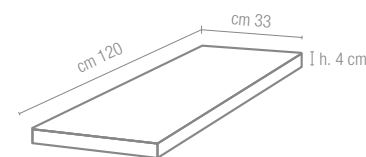

ulivo grigio, ulivo panna cm 20x120 - 7⁷/₈"x47¹/₄"

DECORI DECORS DÉCORS DEKORE

listelli ulivo*



cm 30x30 - 11³/₄"x11³/₄"
listello cm 1,4x30 - 1/2"x11³/₄"
su rete on net sur trame auf Netz

quadrotte ulivo*



cm 30x30 - 11³/₄"x11³/₄"
su rete on net sur trame auf Netz

chevron A*

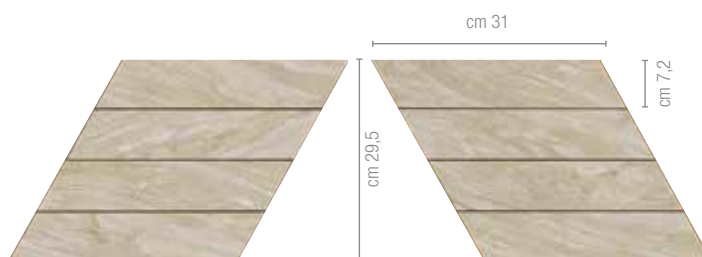

cm 31x29,5 - 12¹/₄"x11⁵/₈" dx / sx
su rete on net sur trame auf Netz



ulivo panna chevron B
cm 14,6x50 - 5³/₄"x19³/₄"

chevron B*



cm 14,6x50
5³/₄"x19³/₄" dx / sx

* Disponibile
in tutti i colori della serie
Available in all the colours
of the series
Disponibile dans tous
les couleurs e la série
Verfügbar in allen Farben

ulivo

GRANITOKER



ulivo tortora cm 20x120 - 7⁷/₈"x47¹/₄"

newood

GRANITOKER



newood grey, newood black cm 15x120 - 5⁷/₈"x47¹/₄" , cm 20x120 - 7⁷/₈"x47¹/₄" , cm 15x90 - 5⁷/₈"x35³/₈"

COLORI COLOURS COULEURS FARBEN

newood black



newood grey



newood wengé



newood brown



newood cream



newood

GRANITOKER

newood beige





newood ivory



newood white



FORMATI SIZES FORMATS FORMATE

Formati Sizes Formats Formate	cm 11x90 4 ³ / ₈ "x35 ³ / ₈ "	cm 15x90 5 ⁷ / ₈ "x35 ³ / ₈ "	cm 22,5x90 8 ⁷ / ₈ "x35 ³ / ₈ "	cm 45x90 17 ³ / ₄ "x35 ³ / ₈ "	cm 15x120 5 ⁷ / ₈ "x47 ¹ / ₄ "	cm 20x120 7 ⁷ / ₈ "x47 ¹ / ₄ "
Superfici Surfaces Surfaces Oberflächen	● ● *	●	●	●	● ● *	● ● *
	mm 10	mm 10	mm 10	mm 10	mm 10	mm 10
 Stonalizzazione media Shade variation medium Variations d'ombre moyenne Farbtonvarianten Mittel						
					● ● *	● ● *
					● Naturale Matt Naturelle Matt R 10 A+B ● Outdoor R 11 A+B+C	

* Disponibile nei colori: Available in the colours: Disponible dans les couleurs: Verfügbar in den folgenden Farben: **Brown, Cream, Grey, Wengé.**

Altri colori sono prodotti solo su richiesta Other colours are produced on demand only Autres teintes disponibles sur demande Andere Farben nur auf Anfrage

Rettificate in un unico calibro Rectified version in a single caliber Rectifiés en un unique calibre Boden Sie in einem einzigen Kaliber

Caratteristiche tecniche e imballi a pagina: Technical features and packing on page: Caractéristiques techniques et emballages à la page: Technische Eigenschaften und Verpackungen auf Seite: **501**

PEZZI SPECIALI TRIMS ACCESSOIRES FORMSTÜCKE

Battiscopa Bullnose
Plinthe à bord arrondi
Stehsockel
cm 9x90 - 3¹/₂"x35³/₈"
cm 9x120 - 3¹/₂"x47¹/₄"



Gradino Step tread
Nez de marche Stufenplatte
cm 30x120 - 11³/₄"x47¹/₄"

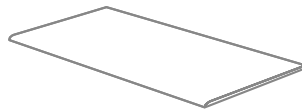

Gradone (assemblato)
cm 120x33 - 47¹/₄"x13"

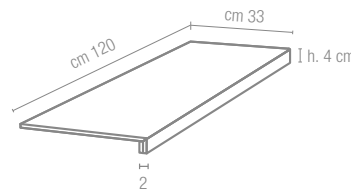

Angolare (assemblato)
cm 120x33 - 47¹/₄"x13"

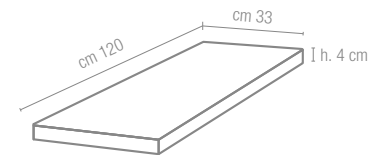

Bordo Terminale Gradino Outdoor
cm 11x90 - 4³/₈"x35³/₈"

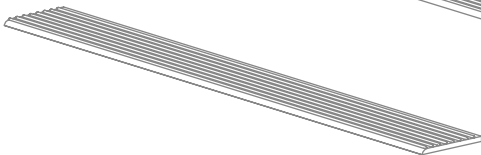

Bordo Terminale Gradino Outdoor
cm 15x120 - 5⁷/₈"x47¹/₄"

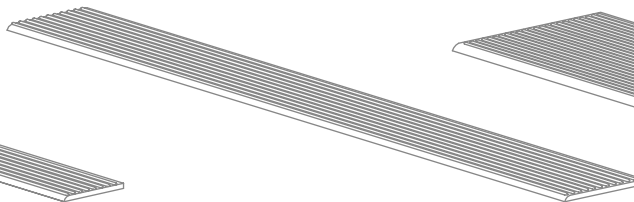

Gradino B.C. Outdoor
cm 30x120 - 11³/₄"x47¹/₄"

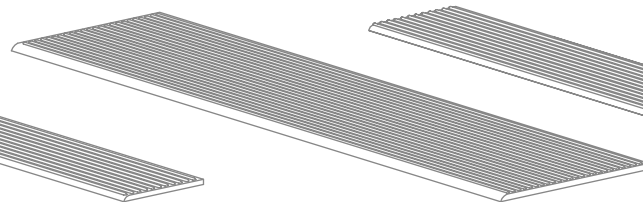

Bordo Terminale Gradino Outdoor
cm 15x60 - 5⁷/₈"x23⁵/₈"

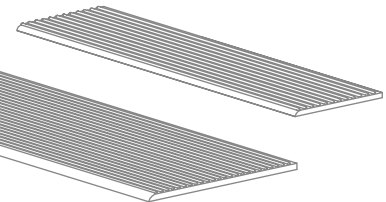

Gradino B.C. Outdoor
cm 30x60 - 11³/₄"x23⁵/₈"

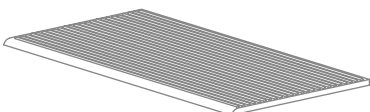

Art. 9660 Pool Wave
cm 60x25 - 23⁵/₈"x9⁷/₈"

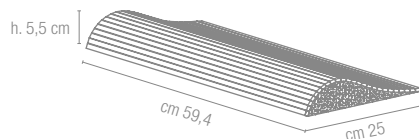

Art. 9667 Pool Wave
cm 30x30 - 11³/₄"x11³/₄"

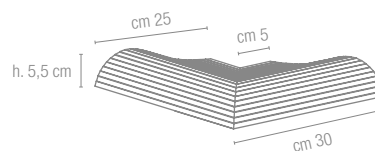

Art. 9668 Pool Wave
cm 30x30 - 11³/₄"x11³/₄"

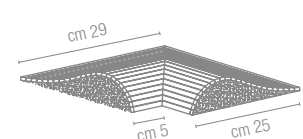

SUPERFICI SURFACES SURFACES OBERFLÄCHEN

newood

GRANITOKER

naturale matt naturelle matt
R10 A+B

outdoor R11 A+B+C

DECORI DECORS DÉCORS DEKORE

mix listelli newood A*



cm 30x30 - 11³/₄"x11³/₄"
 su rete on net sur trame auf Netz

mix listelli newood B*



cm 30x30 - 11³/₄"x11³/₄"
 su rete on net sur trame auf Netz

mix listelli newood C*



cm 30x30 - 11³/₄"x11³/₄"
 su rete on net sur trame auf Netz
 wengé, brown, cream,
 beige, ivory

listelli newood**



cm 30x30 - 11³/₄"x11³/₄"
 su rete on net sur trame auf Netz

listoni newood**



cm 15x90 - 5⁷/₈"x35³/₈"
 su rete on net sur trame auf Netz

* La dimensione delle tessere e la distribuzione dei colori è casuale The dimension of the pieces and the distribution of the colours are random
 La dimension des tesselles et la distribution des couleurs est casuelle Die Abmessung der Steine und die Farbenverteilung sind zufällig

** Disponibile in tutti i colori della serie Available in all the colours of the series
 Disponible dans tous les couleurs de la série Verfügbar in allen farben

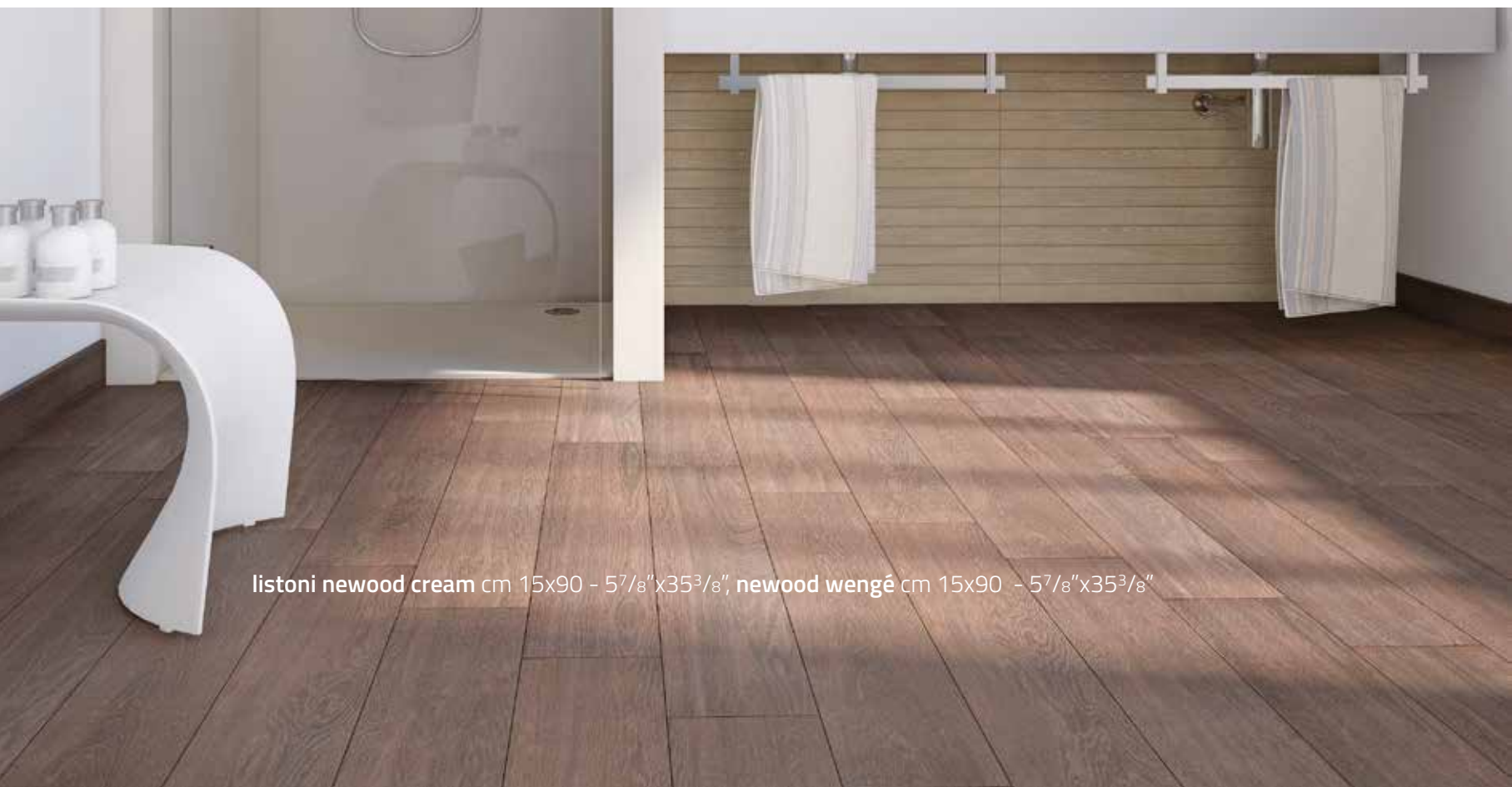

listoni newood cream cm 15x90 - 5⁷/₈"x35³/₈", newood wengé cm 15x90 - 5⁷/₈"x35³/₈"

newood

GRANITOKER

listoni mix newood A

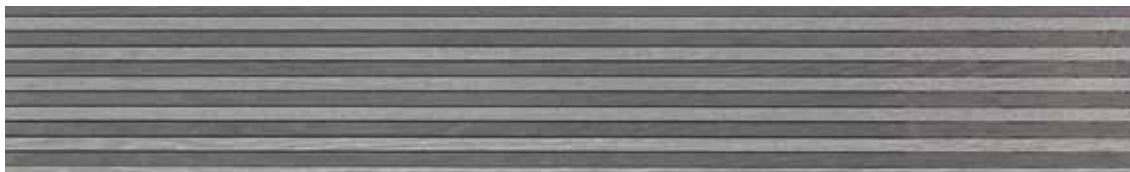

cm 15x90 - 57/8"x35³/8"
su rete on net sur trame auf Netz
black, grey

listoni mix newood B



cm 15x90 - 57/8"x35³/8"
su rete on net sur trame auf Netz
white, grey

listoni mix newood C



cm 15x90 - 57/8"x35³/8"
su rete on net sur trame auf Netz
ivory beige

listoni mix newood D



cm 15x90 - 57/8"x35³/8"
su rete on net sur trame auf Netz
cream brown

listoni mix newood E



cm 15x90 - 57/8"x35³/8"
su rete on net sur trame auf Netz
wengé, beige

metalwood

GRANITOKER



argento, carbonio cm 20x120 - 7⁷/₈"x47¹/₄", cm 15x120 - 5⁷/₈"x47¹/₄", cm 45x90 - 17³/₄"x45³/₈"

COLORI COLOURS COULEURS FARBEN

carbonio



silicio



bronzo



piombo



argento



metalwood

GRANITOKER

iridio





platino



piombo cm 30x60 - 11³/₄"x23⁵/₈"

FORMATI SIZES FORMATS FORMATE

Formati Sizes Formats Formate	cm 10x60 4"x23 ⁵ / ₈ "	cm 30x60 11 ³ / ₄ "x23 ⁵ / ₈ "	cm 60x60 23 ⁵ / ₈ "x23 ⁵ / ₈ "	cm 15x90 5 ⁷ / ₈ "x35 ³ / ₈ "	cm 45x90 17 ³ / ₄ "x35 ³ / ₈ "	cm 15x120 5 ⁷ / ₈ "x47 ¹ / ₄ "	cm 20x120 7 ⁷ / ₈ "x47 ¹ / ₄ "	cm 60x120 23 ⁵ / ₈ "x47 ¹ / ₄ "
Superfici Surfaces Surfaces Oberflächen	●	●	●	●	●	●	●	●
	mm 9	mm 9	mm 10	mm 10	mm 10	mm 10	mm 10	mm 10
 Stonalizzazione media Shade variation medium Variations d'ombre moyenne Farbtonvarianten Mittel								● Naturale Matt Naturelle Matt R9 A

Rettificate in un unico calibro Rectified version in a single caliber Rectifiés en un unique calibre Boden Sie in einem einzigen Kaliber

Nel caso di combinazioni di formati di spessori diversi, specificarlo espressamente nell'ordine

Please specify in your order if you wish to purchase formats including more than one thickness

Prrière de spécifier dans votre commande si vous souhaitez acheter des formats avec différentes épaisseurs

Bitte weisen Sie im Bestellungsformular ausdrücklich darauf hin, wenn Sie Formatkombinationen mit verschiedenen Stärken wünschen

Caratteristiche tecniche e imballi a pagina: Technical features and packing on page: Caractéristiques techniques et emballages à la page: Technische Eigenschaften und Verpackungen auf Seite: **501**

PEZZI SPECIALI TRIMS ACCESSOIRES FORMSTÜCKE

Battiscopa Bullnose
Plinthe à bord arrondi
Stehssockel
cm 9x60 - 3¹/₂"x23⁵/₈"
cm 9x90 - 3¹/₂"x35³/₈"



Gradino Step tread
Nez de marche **Stufenplatte**
cm 30x60 - 11³/₄"x23⁵/₈"

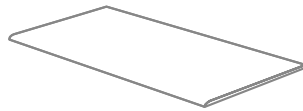

Tozzetto Insert
Caboçon **Einleger**
cm 10x10 - 4"x4"



Gradone (assemblato)*
cm 60x33 - 23⁵/₈"x13"
cm 120x33 - 47¹/₄"x13"

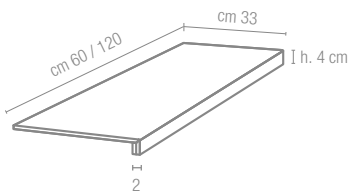

Angolare (assemblato)*
cm 60x33 - 23⁵/₈"x13"
cm 120x33 - 47¹/₄"x13"

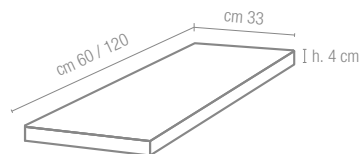

* Disponibile nei colori Available in the colours Disponible dans les couleurs Verfügbar in den folgenden Farben: **Platino, Iridio, Argento, Piombo.**

Altri colori sono prodotti solo su richiesta. Other colours are produced on demand only. Autres teintes disponibles sur demand. Andere Farben nur auf Anfrage.

DECORI DECORS DÉCORS DEKORE

metalwood

GRANITOKER

mix listelli metalwood A

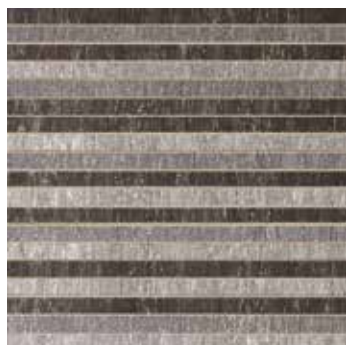

cm 30x30 - 11³/₄"x11³/₄"
listello **cm 1,4x30 - 1/2"x11³/₄"**
su rete on net sur trame auf Netz
silicio, piombo, argento

mix listelli metalwood B



cm 30x30 - 11³/₄"x11³/₄"
listello **cm 1,4x30 - 1/2"x11³/₄"**
su rete on net sur trame auf Netz
bronzo, argento, iridio

mix listelli metalwood C



cm 30x30 - 11³/₄"x11³/₄"
listello **cm 1,4x30 - 1/2"x11³/₄"**
su rete on net sur trame auf Netz
argento, piombo, platino

mosaico listelli*



cm 30x30 - 11³/₄"x11³/₄"
su rete on net sur trame auf Netz

mosaico 6x6*



cm 30x30 - 11³/₄"x11³/₄"
tessera **cm 6x6 - 2³/₈"x2³/₈"**
su rete on net sur trame auf Netz

fascia metalwood*



cm 10x60 - 4"x23⁵/₈"

* Disponibile in tutti i colori della serie Available in all the colours of the series
Disponibile dans tous les couleurs de la série Verfügbar in allen farben

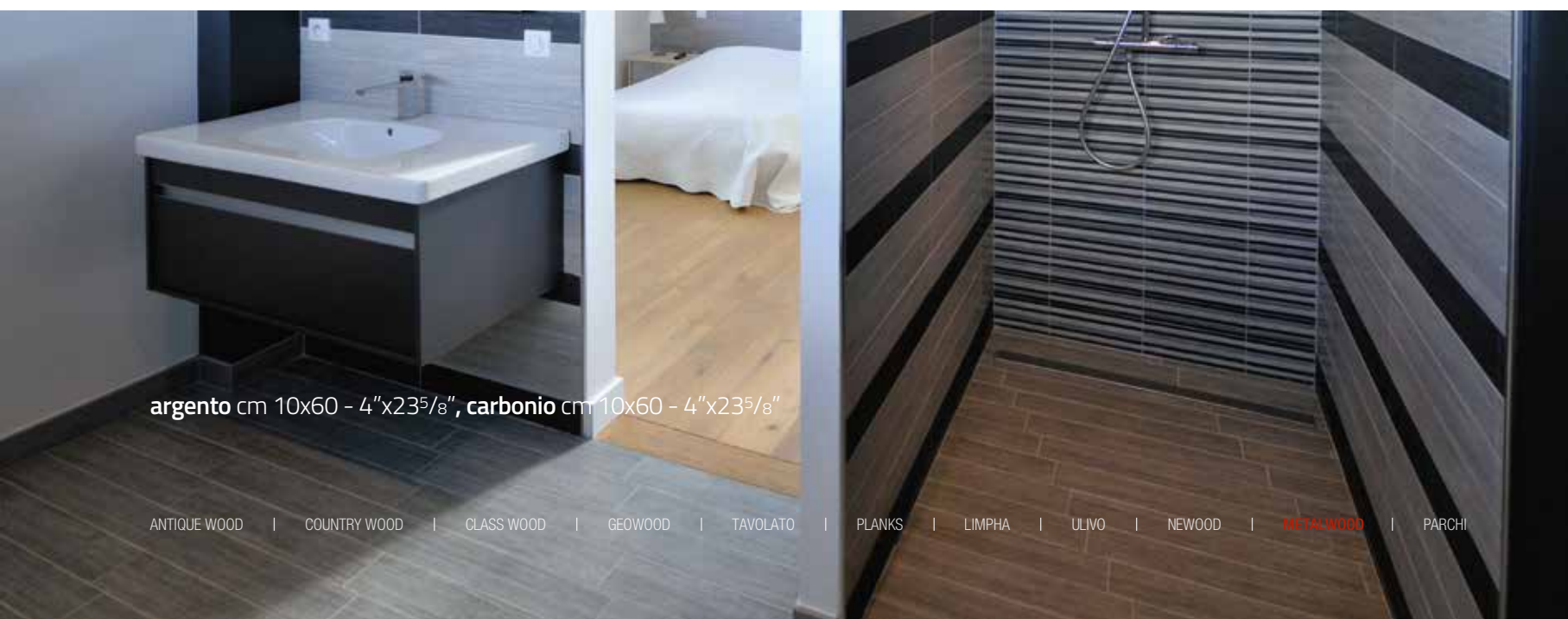

argento cm 10x60 - 4"x23⁵/₈", carbonio cm 10x60 - 4"x23⁵/₈"



parchi

GRESPLUS



sequoia cm 41,5x41,5 - 16³/₈"x 16³/₈"





COLORI COLOURS COULEURS FARBEN

sequoia

yellowstone



FORMATI SIZES FORMATS FORMATE

Formati Sizes Formats Formate		
	cm 41,5x41,5 16 ³ / ₈ "x16 ³ / ₈ "	cm 60x60** 23 ⁵ / ₈ "x23 ⁵ / ₈ "
Sequoia G4*	●	●
Yellowstone G4*	●	●
	mm 8,8 R10	mm 20 R11 A+B+C
 Stonalizzazione accentuata Shade variation accentuated Variations d'ombre forte Farbtonvarianten Akzentuiert		● Naturale Matt Naturelle Matt

* Vedi pagina: See page: Voir page Siehe Seite: **501**

** Rettificate in un unico calibro Rectified version in a single caliber Rectifiés en un unique calibre Boden Sie in einem einzigen Kalibe

parchi

GRESPLUS



yellowstone cm 60x60 - 23⁵/₈"x23⁵/₈"

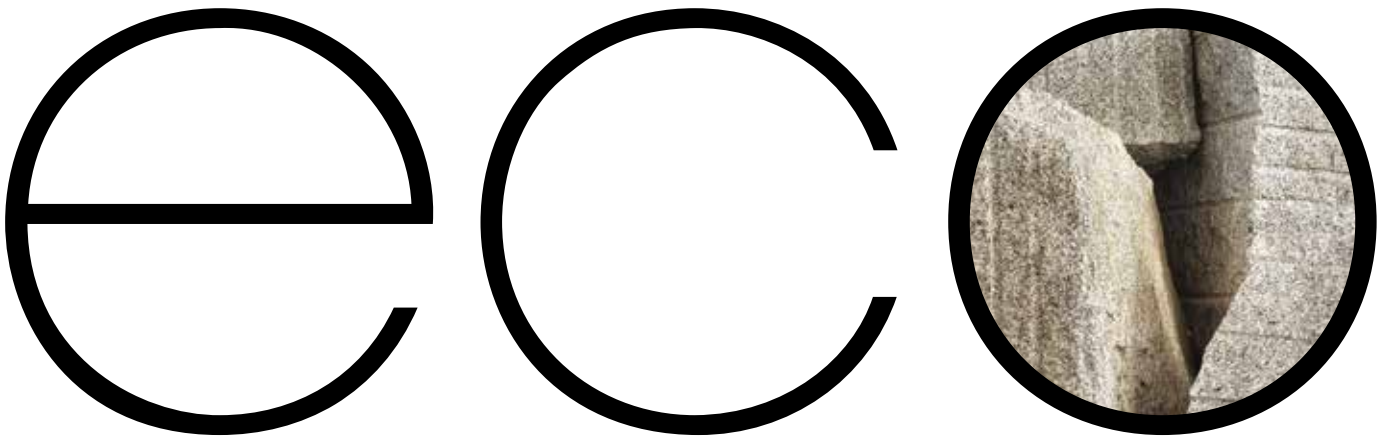

eco**granite** éco**granit** öko**granit**

granito

eco**granito**

312 **granito 1 evo**

316 **granito 1**

324 **granito 2**

330 **granito 3**

336 **granito 4**

GRANITO

Roccia fanero cristallina da costruzione e decorazione, compatta e lucidabile, prevalentemente costituita da minerali di durezza Mohs da 6 a 7, come i quarzi, i feldspati e i feldspatoidi. In funzione della loro composizione possono essere distinti: i graniti propriamente detti [rocce magmatiche intrusive acide fanero-cristalline, costituite da quarzo, feldspati sodico potassici e miche]; altre rocce magmatiche intrusive (dioriti, granodioriti, sieniti, gabbri eccetera); rocce magmatiche effusive a struttura porfirica; alcune rocce metamorfiche di analoga composizione come gneiss e serizzi.

GRANITE

Crystalline phaneritic rock for decorative and building purposes. It is compact, can be polished and mainly consists of minerals with 6 to 7 Mohs hardness such as quartzes, feldspars and feldspathoids. Depending on their composition, granites include: granite in the strict sense of the term [phaneritic-crystalline intrusive magmatic acid rocks consisting of quartz, soda potash feldspars and micas]; other intrusive magmatic rocks (diorites, granodiorites, syenites, gabbros, etc); magmatic effusive rock with a porphyritic structure; certain metamorphic rocks of similar composition, such as gneiss and paragneiss.



granito 1evo

GRANITOGRES



denver cm 30x30 - 11³/₄"x11³/₄"

COLORI COLOURS COULEURS FARBEN

new york



chicago



denver



seattle



tucson











boston



FORMATI SIZES FORMATS FORMATE



granito 1evo

GRANITOGRES

Formati Sizes Formats Formate	 cm 30x30 11 ³ / ₄ "x11 ³ / ₄ "	 cm 45x45 17 ³ / ₄ "x17 ³ / ₄ "	 cm 30x60 11 ³ / ₄ "x23 ⁵ / ₈ "	 cm 60x60* 23 ⁵ / ₈ "x23 ⁵ / ₈ "
Superfici Surfaces Surfaces Oberflächen				
	mm 7,6	mm 9	mm 9	mm 10 mm 14**



Stonizzazione Uniforme
Shade variation Uniform
Variations d'ombre Uniforme
Farbtonvarianten Einheitlich

 Naturale Matt Naturelle Matt **R10 A**
 Secura **R11 A+B**

* Rettificate in un unico calibro Rectified version in a single caliber Rectifiés en un unique calibre Boden Sie in einem einzigen Kaliber

** Solo nei colori: Only in the colours: Seulement dans les couleurs : Nur in die Farben: **Boston, Denver, Seattle**

Caratteristiche tecniche e imballi a pagina: Technical features and packing on page: Caractéristiques techniques et emballages à la page: Technische Eigenschaften und Verpackungen auf Seite: **494**

PEZZI SPECIALI TRIMS ACCESSOIRES FORMSTÜCKE

Battiscopa Bullnose
Plinthe à bord arrondi
Stehsockel

cm 9x45 - 3¹/₂"x17³/₄"
cm 9x30 - 3¹/₂"x11³/₄"
cm 9x60 - 3¹/₂"x 23⁵/₈"



Zoccolo a raccordo a taglio retto

Cove base - straight top
Plinthe à gorge avec bord vif
Hohlkehlssockel (scharfkantig)
cm 10x30 - 4"x11³/₄"

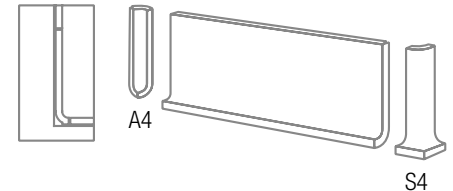

Gradino Step tread
Nez de marche Stufenplatte
cm 30x30 - 11³/₄"x11³/₄"

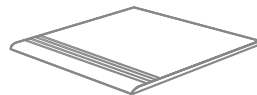

Zoccolo ad appoggio smussato
Sit-on skirting - bevelled top
Plinthe à talon avec bord arrondi
Aufsetzsockel mit abgerundeter Kante
cm 10x30 - 4"x11³/₄"

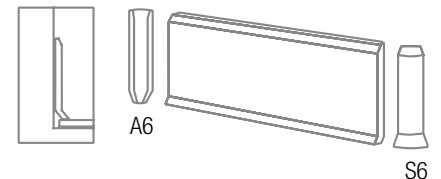

granito 1

GRANITOGRES



nebraska cm 30x60 - 11³/₄"x23⁵/₈"

COLORI COLOURS COULEURS FARBEN

dakota



ontario



giamaica



arizona



arkansas



sahara

granito 1

GRANITOGRES

minnesota



georgia



labrador



everest



nebraska



nevada

COLORI COLOURS COULEURS FARBEN

marocco



colorado



iberia

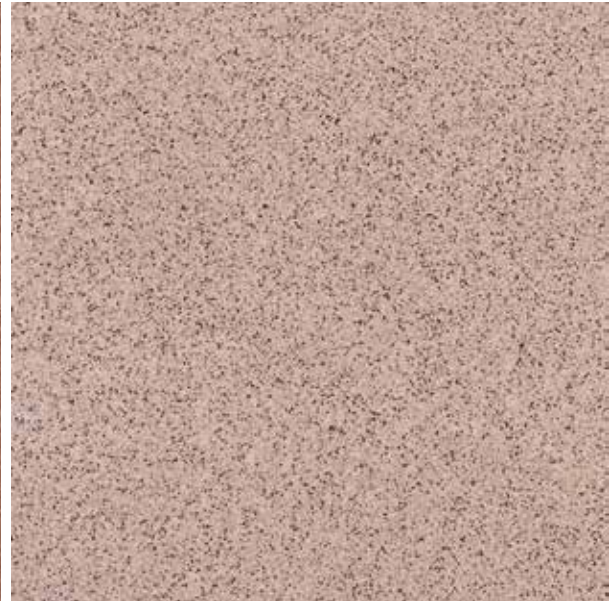

tibet



catalogna

SUPERFICI SURFACES
SURFACES OBERFLÄCHEN







granito 1

GRANITOGRES

levigata polished polie poliert

naturale matt
naturelle matt
R9 A

FORMATI SIZES FORMATS FORMATE

						
Formati Sizes Formats Formate	cm 15x15 5 ⁷ / ₈ "x5 ⁷ / ₈ "	cm 10x20 4"x7 ⁷ / ₈ "	cm 20x20 7 ⁷ / ₈ "x7 ⁷ / ₈ "	cm M 12,5x25** 4 ⁷ / ₈ "x9 ⁷ / ₈ "	cm 30x30 11 ³ / ₄ "x11 ³ / ₄ "	cm 40x40 15 ³ / ₄ "x15 ³ / ₄ "
Arizona			●		● ●	
Arkansas	● ●	●	● ●	●	● ● ●	● ●
Catalogna			●		● ●	
Colorado		●	● ●	●	● ● ●	● ●
Dakota			●		● ●	
Everest			●		● ●	
Georgia		●	● ●	●	● ● ●	● ●
Giamaica			●		● ●	
Iberia			●		● ●	
Labrador		●	● ●	●	● ● ●	● ●
Marocco			●		● ●	
Minnesota			●		● ●	
Nebraska	● ●	●	● ●	●	● ● ●	● ●
Nevada			●		● ●	
Ontario	● ●	●	● ●	●	● ● ●	● ●
Sahara		●	● ●	●	● ● ●	● ●
Tibet			●		● ●	
	mm 8	mm 8	mm 8	mm 8	mm 8	mm 9



Stonizzazione Uniforme
Shade variation Uniform
Variations d'ombre Uniforme
Farbtonvarianten Einheitlich

● Naturale Matt Naturelle Matt **R9 A**
● Levigata Polished Polie Poliert
● Technic **R10**

* Spessore su superficie naturale Thickness on matt surface Épaisseur sur surface naturelle Stärke der Fliesen mit Mattoberfläche

** Misure di fabbricazione: Worksizes: Cotes de fabrication: Herstellmasse: **cm 11,8x24,3**

Per superfici speciali antiscivolo e spessori maggiorati vedere collezione Technic a pag: For increased thicknesses and special no-slip surfaces see the Technic collection on page:

Pour des surfaces antiderapantés et les épaisseurs majorés, voir collection Technic à la page: Für sonderrutschhemmende Oberflächen und Stärken siehe Kollektion Technic auf Seite: **476**

Caratteristiche tecniche e imballi a pagina: Technical features and packing on page: Caractéristiques techniques et emballages à la page: Technische Eigenschaften und Verpackungen auf Seite: **494**

PEZZI SPECIALI TRIMS ACCESSOIRES FORMSTÜCKE

granito 1

GRANITOGRES

Battiscopa Bullnose
Plinthe à bord arrondi
Stehsockel
cm 9x30 - 3½"x11¾"
cm 9x40 - 3½"x15¾"
cm 10x20 - 4"x7⅞"

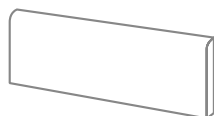

Zoccolo a raccordo a taglio retto*
Cove base - straight top*
Plinthe à gorge avec bord vif*
Hohlkehlsocbel (scharfkantig)*
cm 10x20 - 4"x7⅞"

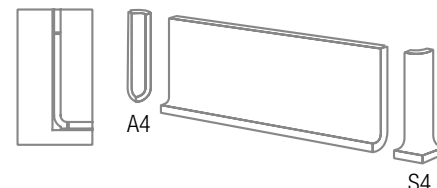

Gradino Step tread
Nez de marche Stufenplatte
cm 30x30 - 11¾"x11¾"

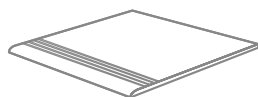

Zoccolo ad appoggio smussato*
Sit-on skirting - bevelled top*
Plinthe à talon avec bord arrondi*
Aufsetzsockel mit abgerundeter Kante*
cm 10x20 - 4"x7⅞"

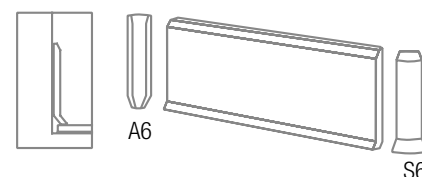

Listello Listel
Listel Zeierleiste
cm 9x30 - 3½"x11¾"
cm 9x40 - 3½"x15¾"

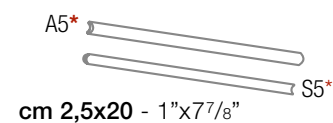

Sguscetta* Cove*
Gorge* Rinnleiste*
cm 4x20 - 1⅝"x7⅞"



Tozzetto Insert
Cabochon Einleger
cm 9x9 - 3½"x 3½"

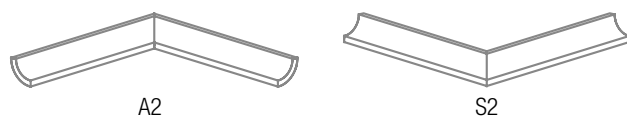

Terminale
Step tread Rebord
Beckenrandplatte
cm 30x30 - 11¾"x11¾"

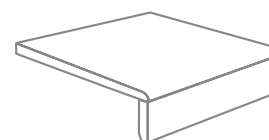

* Produzione corrente solo nei colori: Currently produced only in the following colours: Productions courantes seulement dans les couleurs: Aktuelle Produktion nur in den Farben: **Arkansas, Colorado, Georgia, Labrador, Nebraska, Ontario, Sahara**

Altri colori sono prodotti solo su richiesta Other colours are produced on demand Autres teintes disponibles sur demand Andere Farben nur auf Antrag

arkansas cm 30x30 - 11¾"x11¾"

granito 2

GRANITOGRES



genova, milano, tactile cm 30x30 - 11³/₄"x11³/₄"

COLORI COLOURS COULEURS FARBEN

milano



venezia



cortina

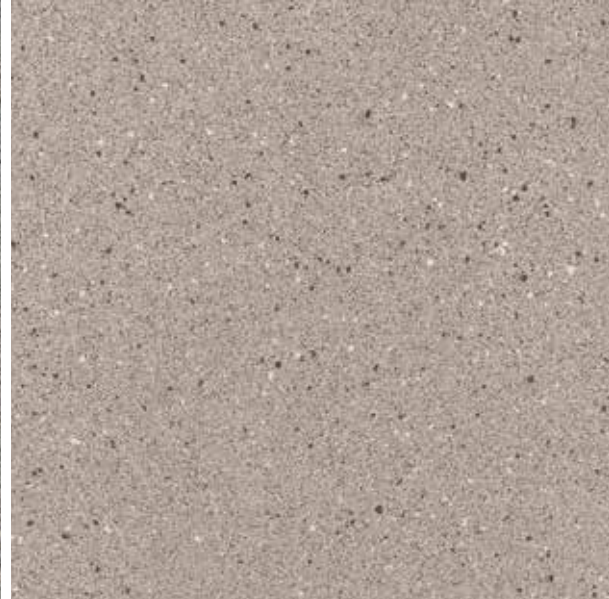

torino



genova



siena

granito 2

GRANITOGRES

cervinia





amalfi



gallipoli

FORMATI SIZES FORMATS FORMATE

Formati Sizes Formats Formate	 cm 30x30 11 ³ / ₄ "x11 ³ / ₄ "
Amalfi	  
Cervinia	  
Cortina	  
Gallipoli	  
Genova	  
Milano	  
Siena	  
Torino	  
Venezia	  
 *	mm 8,3



Stonilizzazione Uniforme
Shade variation Uniform
Variations d'ombre Uniforme
Farbtonvarianten Einheitlich

 Naturale Matt Naturelle Matt **R10 A**
 Levigata Polished Polie Poliert
 Rocchia **R12 A+B**

* Spessore su superficie naturale Thickness on matt surface Épaisseur sur surface naturelle Stärke der Fliesen mit Mattoberfläche

Caratteristiche tecniche e imballi a pagina: Technical features and packing on page: Caractéristiques techniques et emballages à la page: Technische Eigenschaften und Verpackungen auf Seite: **494**

PEZZI SPECIALI TRIMS ACCESSOIRES FORMSTÜCKE

Battiscopa Bullnose
Plinthe à bord arrondi
Stehsockel
cm 9x30 - 3¹/₂"x11³/₄"

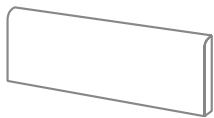

Gradino Step tread
Nez de marche Stufenplatte
cm 30x30 - 11³/₄"x11³/₄"

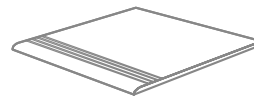

Listello Listel
Listel Zeierleiste
cm 9x30 - 3¹/₂"x11³/₄"



Tozetto Insert
Cabochon Einleger
cm 9x9 - 3¹/₂"x 3¹/₂"



SUPERFICI SURFACES
SURFACES OBERFLÄCHEN

granito 2

GRANITOGRES

levigata polished polie poliirt

naturale matt
naturelle matt
R10 A

granito 3

GRANITOGRES



madrid cm 30x30 - 11³/₄"x11³/₄", unicolore listello giallo e nero

COLORI COLOURS COULEURS FARBEN

budapest



montreal



shanghai



madrid

ajaccio

tokyo

granito 3

GRANITOGRES

casablanca

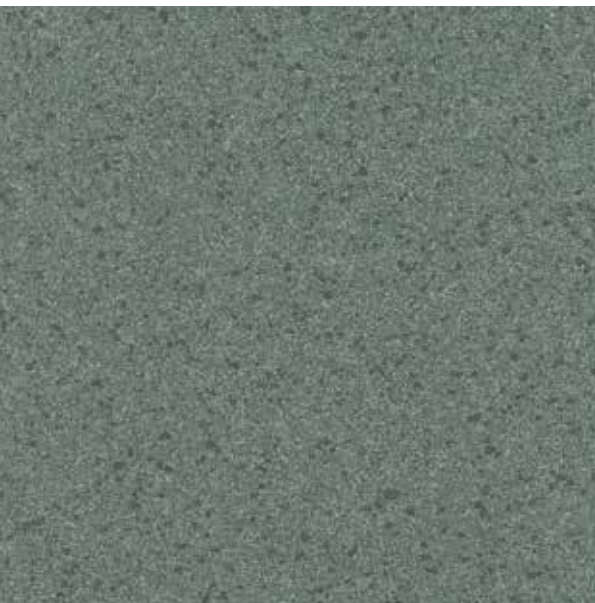

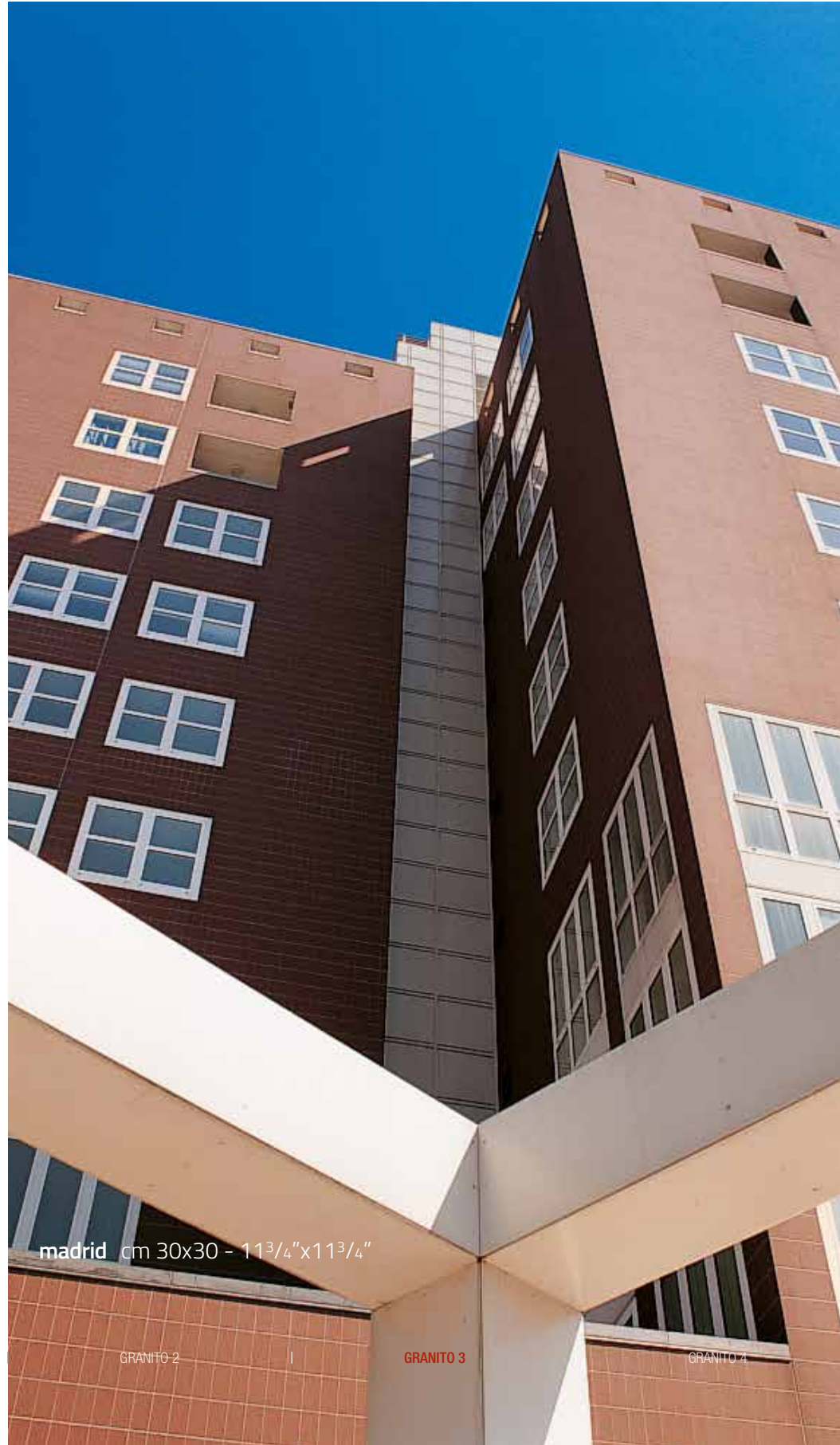

helsinki



madrid cm 30x30 - 11³/₄"x11³/₄"

FORMATI SIZES FORMATS FORMATE

Formati Sizes Formats Formate	 cm 30x30 11 ³ / ₄ "x11 ³ / ₄ "
Ajaccio	● ●
Budapest	● ●
Casablanca	● ●
Helsinki	● ●
Madrid	● ●
Montreal	● ●
Shanghai	● ●
Tokyo	● ●
 *	mm 8,3
 Stonalizzazione Uniforme Shade variation Uniform Variations d'ombre Uniforme Farbtonvarianten Einheitlich	● Naturale Matt Naturelle Matt R10 A ● Levigata Polished Polie Poliert

* Spessore su superficie naturale Thickness on matt surface Épaisseur sur surface naturelle Stärke der Fliesen mit Mattoberfläche

Caratteristiche tecniche e imballi a pagina: Technical features and packing on page: Caractéristiques techniques et emballages à la page: Technische Eigenschaften und Verpackungen auf Seite: **494**

PEZZI SPECIALI TRIMS ACCESSOIRES FORMSTÜCKE

Battiscopa Bullnose
Plinthe à bord arrondi
Stehsockel
cm 9x30 - 3¹/₂"x11³/₄"

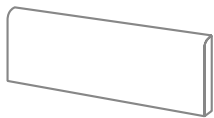

Gradino Step tread
Nez de marche **Stufenplatte**
cm 30x30 - 11³/₄"x11³/₄"

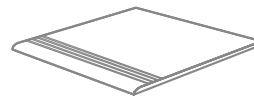

Listello Listel
Listel **Zeierleiste**
cm 9x30 - 3¹/₂"x11³/₄"



Tozetto Insert
Cabochon **Einleger**
cm 9x9 - 3¹/₂"x 3¹/₂"



SUPERFICI SURFACES
SURFACES OBERFLÄCHEN

granito 3

GRANITOGRES

levigata polished polie poliert

naturale matt
naturelle matt
R10 A

granito 4

GRANITOGRES



fiji levigata polished cm 60x60 - 23⁵/₈"x23⁵/₈"

COLORI COLOURS COULEURS FARBEN

hawaii



madagascar



fiji

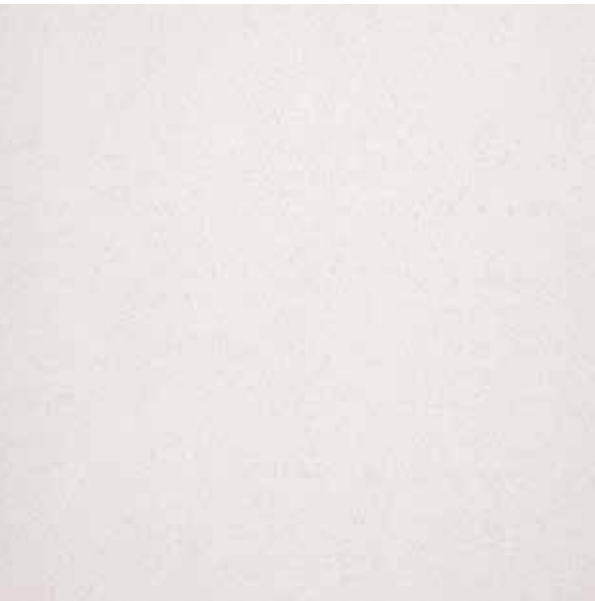

groenlandia

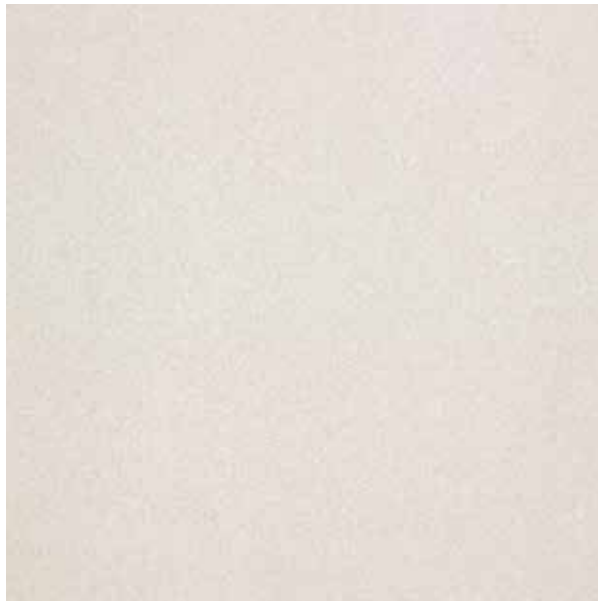

islanda









granito 4

GRANITOGRES



hawaii bocciardata cm 60x60 - 23⁵/₈"x23⁵/₈"

FORMATI SIZES FORMATS FORMATE

Formati Sizes Formats Formate	 cm 30x30 11 ³ / ₄ "x11 ³ / ₄ "	 cm 60x60 23 ⁵ / ₈ "x23 ⁵ / ₈ "
Superfici Surfaces Surfaces Oberflächen		
	mm 10	mm 10
 Stonalizzazione Uniforme Shade variation Uniform Variations d'ombre Uniforme Farbtonvarianten Einheitlich		<ul style="list-style-type: none">  Naturale Matt Naturelle Matt R9  Levigata Polished Polie Poliert  Bocciardata R12 A+B+C

Rettificate in un unico calibro Rectified version in a single caliber Rectifiés en un unique calibre Boden Sie in einem einzigen Kaliber

Caratteristiche tecniche e imballi a pagina: Technical features and packing on page: Caractéristiques techniques et emballages à la page: Technische Eigenschaften und Verpackungen auf Seite: **494**

PEZZI SPECIALI TRIMS ACCESSOIRES FORMSTÜCKE

Battiscopa Bullnose
Plinthe à bord arrondi
Stehsockel
cm 9x60 - 3¹/₂"x11³/₄"



Gradino Step tread
Nez de marche **Stufenplatte**
cm 30x60 - 11³/₄"x11³/₄"

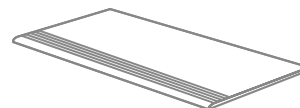

madagascar, groenlandia *levigata* cm 60x60 - 23⁵/₈"x23⁵/₈"

SUPERFICI SURFACES
SURFACES OBERFLÄCHEN

granito 4

GRANITOGRES

levigata polished
polie poliert

naturale matt
naturelle matt
R9

bocciardata bocciardata bouchardée gehämmert
R12 A+B+C

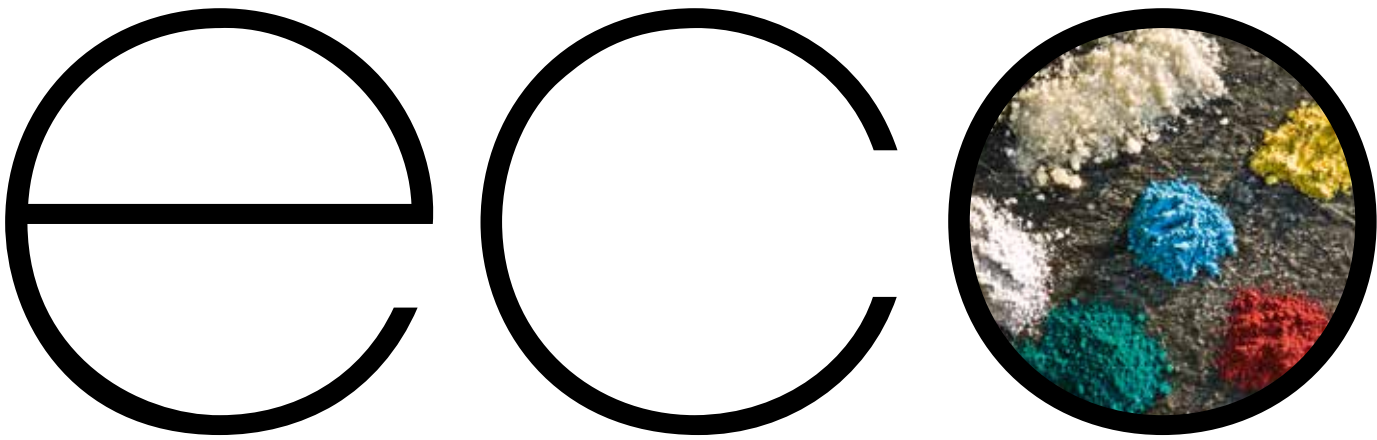

eco**colour** éco**couleur** öko**farbe**

colore

eco**colore**

- 346 **earth**
- 354 **architecture**
- 366 **unicolore**
- 374 **caleidoscopio**
- 382 **elementi**
- 388 **landscape**

COLORE

COLOUR

La luce riflessa di un corpo, che si diversifica in base alla lunghezza d'onda della radiazione o delle radiazioni elettromagnetiche di cui è costituita. Possono essere distinti: colori semplici, cioè costituiti da una sola radiazione, come i colori fondamentali o dell'iride (rosso, arancio, giallo, verde, azzurro, indaco, violetto); colori composti, costituiti da più radiazioni; colori complementari, dalla cui sovrapposizione si ottiene la luce bianca; colori soggettivi, prodotti dalla sensazione fisiologica delle radiazioni sulla retina dell'occhio mediante la quale percepiamo la loro diversità.

The reflected light of a body that changes, depending on the wave length of the electromagnetic radiation or radiations of which it is made. There are: simple colours, i.e., formed by a single radiation, such as the primary colours or those of the iris (red, orange, yellow, green, sky blue, indigo, violet); compound colours, formed by several radiations; complementary colours, from which a white light is obtained when they are overlapped; subjective colours, produced by the physiological sensation created by the radiations on the retina of the eye with which we perceive their diversity.

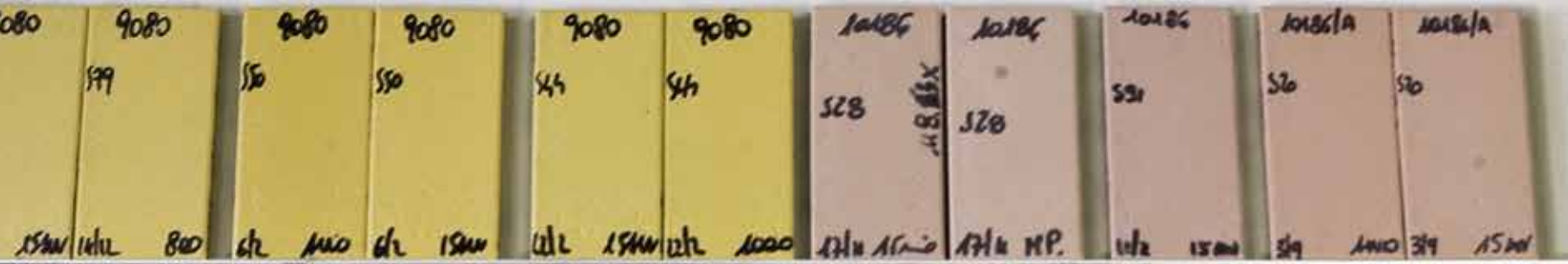
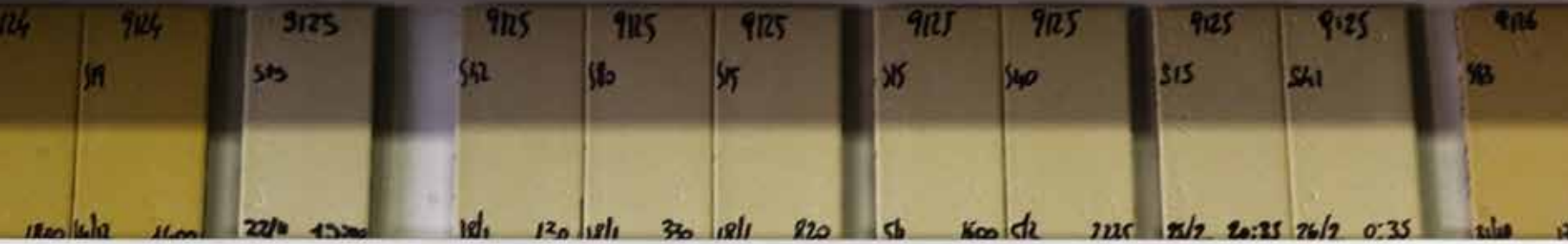
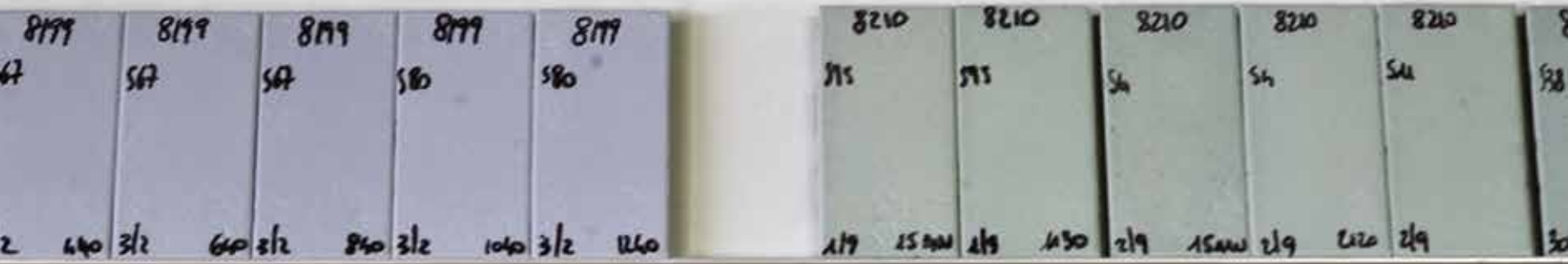

earth by pininfarina

GRANITOKER



earth grigio 4, earth grigio 1 cm 60x120 - 23⁵/₈"x47¹/₄", 30x120 - 11³/₄"x47¹/₄, 15x120 - 5⁷/₈"x47¹/₄"

COLORI COLOURS COULEURS FARBEN

earth blu



earth grigio 4

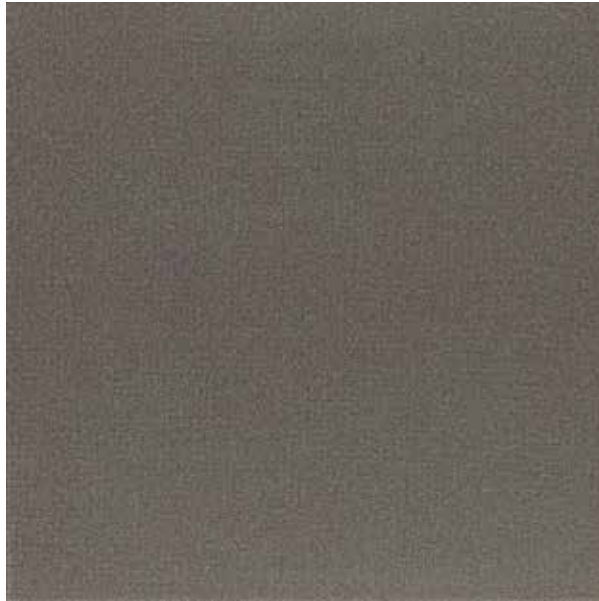

earth grigio 3

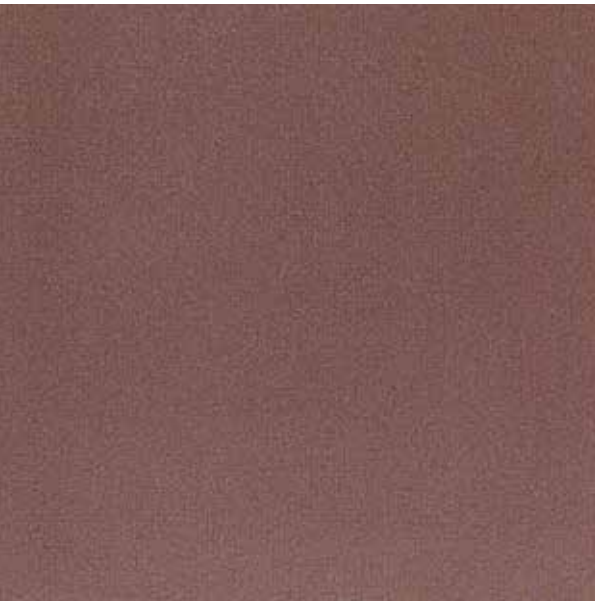
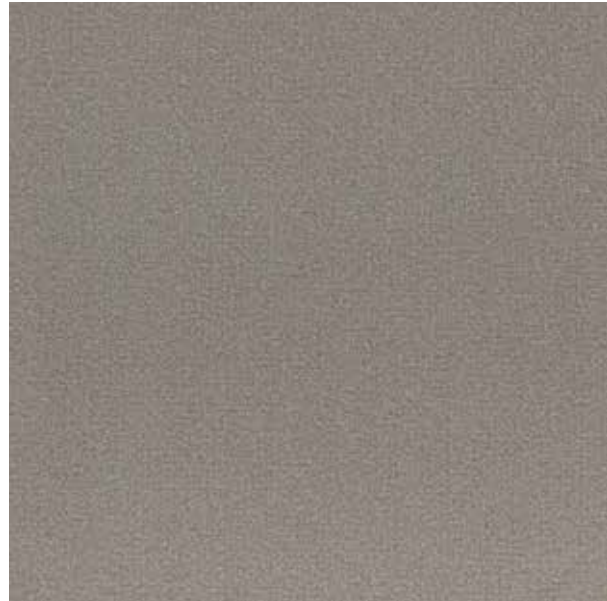

earth brunello



earth metalred



earth tortora 4

earth by pininfarina

GRANITOKER

earth grigio 2

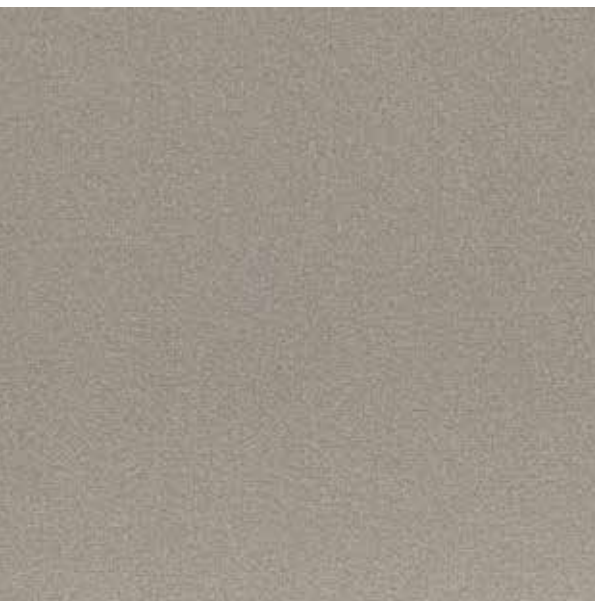

earth grigio 1



earth bianco



earth tortora 3

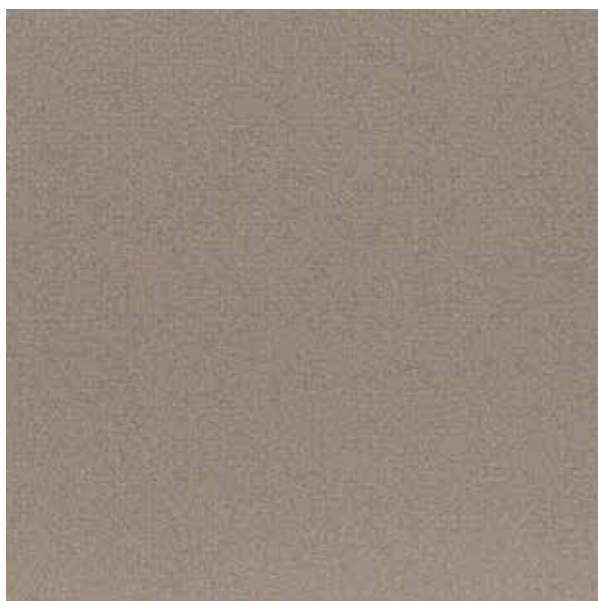

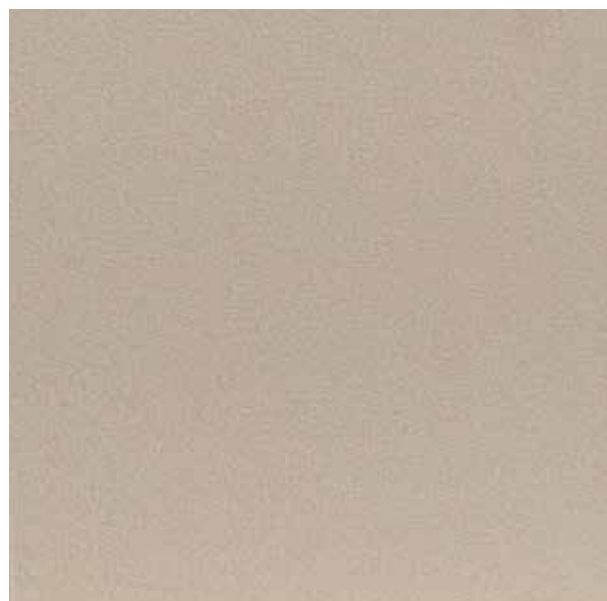

earth tortora 2



earth tortora 1

FORMATI SIZES FORMATS FORMATE

Formati Sizes Formats Formate	cm 30x60 11 ³ / ₄ "x23 ⁵ / ₈ "	cm 60x60 23 ⁵ / ₈ "x23 ⁵ / ₈ "	cm 15x120 5 ⁷ / ₈ "x47 ¹ / ₄ "	cm 30x120 11 ³ / ₄ "x47 ¹ / ₄ "	cm 60x120 23 ⁵ / ₈ "x47 ¹ / ₄ "
Superfici Surfaces Surfaces Oberflächen	●	●	●	●	●
	mm 10	mm 10	mm 10	mm 10	mm 10
 Stonalizzazione media Shade variation medium Variations d'ombre moyenne Farbtonvarianten Mittel	● Naturale Matt Naturelle Matt R10				

Rettificate in un unico calibro Rectified version in a single caliber Rectifiés en un unique calibre Boden Sie in einem einzigen Kaliber

Caratteristiche tecniche e imballi a pagina: Technical features and packing on page: Caractéristiques techniques et emballages à la page: Technische Eigenschaften und Verpackungen auf Seite: **501**

PEZZI SPECIALI TRIMS ACCESSOIRES FORMSTÜCKE

Battiscopa Bullnose
Plinthe à bord arrondi
Stehsockel
cm 9x60 - 3¹/₂"x23⁵/₈"



Terminale Chrome/Silver
cm 1x60 - ³/₈"x23⁵/₈"



Spigolo listello Chrome/Silver
cm 1x3,6 - ³/₈"x1³/₈"



Spigolo terminale Chrome/Silver
cm 1x1 - ³/₈"x³/₈"



Gradone (assemblato)
cm 60x33 - 23⁵/₈"x13"

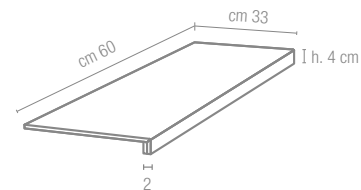

Angolare (assemblato)
cm 60x33 - 23⁵/₈"x13"

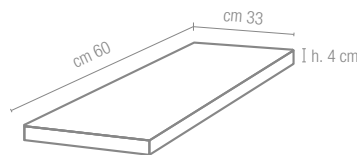

Gradino Step tread
Nez de marche **Stufenplatte**
cm 30x60 - 11³/₄"x23⁵/₈"

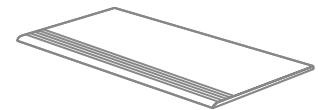

LOGO

Piastrella con firma in acciaio.
Disponibile in tutti i formati
e colori della collezione.

Tile with steel signature.
Available in all the sizes
of the collection.

Dalle avec signature en acier.
Disponible dans tous
les formats et dans toutes
les couleurs de la collection.

Fliese mit Signatur aus Stahl.
Verfügbar in allen Farben
und Formaten der Kollektion.

earth by pininfarina

GRANITOKER

pininfarina

pininfarina

DECORI DECORS DÉCORS DEKORE

line*

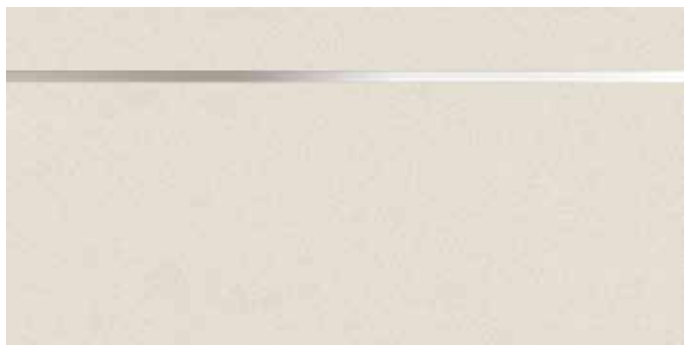

cm 30x60 - 11³/₄"x23⁵/₈"
 cm 60x120 - 23⁵/₈"x47¹/₄"
 cm 30x120 - 11³/₄"x47¹/₄"
 cm 15x120 - 5⁷/₈"x47¹/₄"

- * Piastrella con inserto bacchetta argento.
Disponibile in tutti i colori della serie
Tile with a silver border strip.
Available in all the colours of the series
Dalle avec insert pour baguette argent.
Disponibile dans toutes les couleurs de la série
Fliese mit Zierleisteneinsatz aus Silber.
Verfügbar in allen Farben

varnish

listello mirror silver*



cm 3,6x60 - 1³/₈"x23⁵/₈"
 cm 3,6x120 - 1³/₈"x47¹/₄"

listello blu chrome**

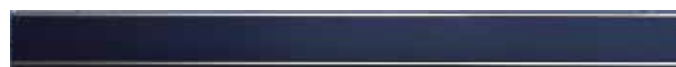

cm 3,6x60 - 1³/₈"x23⁵/₈"
 cm 3,6x120 - 1³/₈"x47¹/₄"

listello red chrome**



cm 3,6x60 - 1³/₈"x23⁵/₈"
 cm 3,6x120 - 1³/₈"x47¹/₄"

- * Cromato Chrome-plated Chromé Chrom

- ** In vernice micallizzata Made of 'mica' varnish
En 'mica' peinture Aus 'mica' Anstrich

Listello Logo con firma Pininfarina (un pezzo per scatola)
 With Pininfarina signature (one piece per box)
 Avec signature Pininfarina (une pièce pour boîte)
 Mit Signatur Pininfarina (ein Stück pro Karton)

earth metalred,
listello radica silver

cm 15x120 - 5⁷/₈"x47¹/₄"
 30x120 - 11³/₄"x47¹/₄"
 60x120 - 23⁵/₈"x47¹/₄"
 3,6x120 - 1³/₈"x47¹/₄"



listello mirror silver, line, earth blu

cm 15x120 - 5⁷/₈"x47¹/₄"
 30x120 - 11³/₄"x47¹/₄"
 60x120 - 23⁵/₈"x47¹/₄"
 3,6x120 - 1³/₈"x47¹/₄"



earth by pininfarina

GRANITOKER

wood

listello radica silver*



cm 3,6x60 - 1³/₈"x23⁵/₈"
cm 3,6x120 - 1³/₈"x47¹/₄"

listello palissandro silver*



cm 3,6x60 - 1³/₈"x23⁵/₈"
cm 3,6x120 - 1³/₈"x47¹/₄"

listello daniela silver*



cm 3,6x60 - 1³/₈"x23⁵/₈"
cm 3,6x120 - 1³/₈"x47¹/₄"

* In legno naturale Made of real wood
En bois véritable Aus echtem Holz

Listello Logo con firma Pininfarina (un pezzo per scatola)
With Pininfarina signature (one piece per box)
Avec signature Pininfarina (une pièce pour boîte)
Mit Signatur Pininfarina (ein Stück pro Karton)

leather

listello nubia chrome*



cm 3,6x60 - 1³/₈"x23⁵/₈"
cm 3,6x120 - 1³/₈"x47¹/₄"

listello castagna*



cm 3,6x60 - 1³/₈"x23⁵/₈"
cm 3,6x120 - 1³/₈"x47¹/₄"

listello rojo chrome*



cm 3,6x60 - 1³/₈"x23⁵/₈"
cm 3,6x120 - 1³/₈"x47¹/₄"

* In vera pelle Made of genuine leather
En cuir naturel Aus echtem Leder

Listello Logo con firma Pininfarina (un pezzo per scatola)
With Pininfarina signature (one piece per box)
Avec signature Pininfarina (une pièce pour boîte)
Mit Signatur Pininfarina (ein Stück pro Karton)

listello daniela silver,
line, earth tortora 2,
earth tortora 2,
earth tortora 4, earth bianco
cm 30x60 - 11³/₄"x 23⁵/₈",
60x60 - 23⁵/₈"x23⁵/₈",
3,6x60 - 1³/₈"x23⁵/₈"

listello castagna chrome,
earth tortora 1, earth tortora 3
cm 15x120 - 5⁷/₈"x47¹/₄",
30x120 - 11³/₄"x47¹/₄",
60x120 - 23⁵/₈"x47¹/₄",
3,6x120 - 1³/₈"x47¹/₄"

architecture

GRANITOGRES



architecture cool grey *matt* cm 90x90 - 35³/₈"x35³/₈"

COLORI COLOURS COULEURS FARBEN

architecture black matt



architecture black gloss



architecture dark grey matt

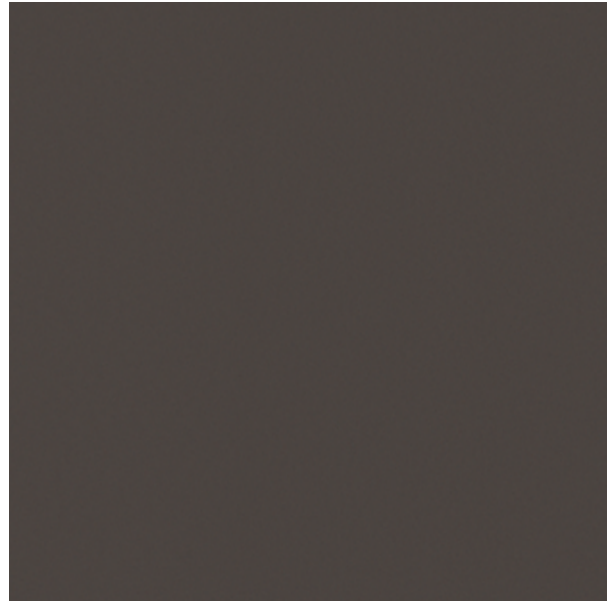

architecture light grey matt

architecture light grey gloss

architecture cool grey matt

architecture

GRANITOGRES

architecture dark grey gloss



architecture medium grey matt



architecture medium grey gloss



architecture cool grey gloss

architecture warm grey matt

architecture warm grey gloss

COLORI COLOURS COULEURS FARBEN

architecture dark brown matt

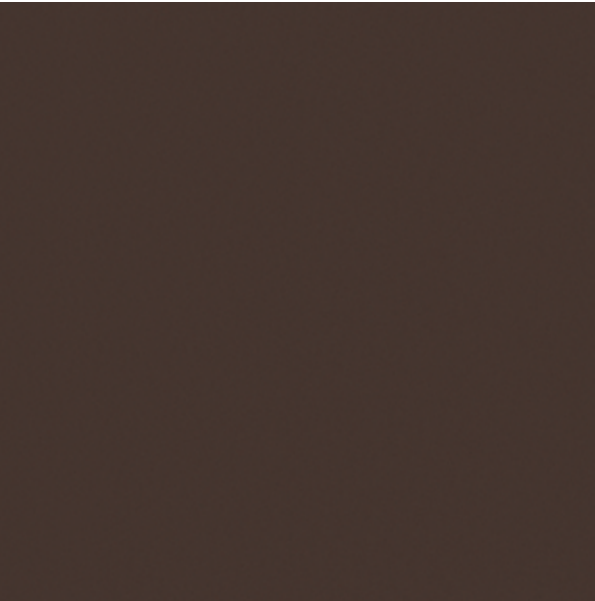

architecture dark brown gloss



architecture light brown matt

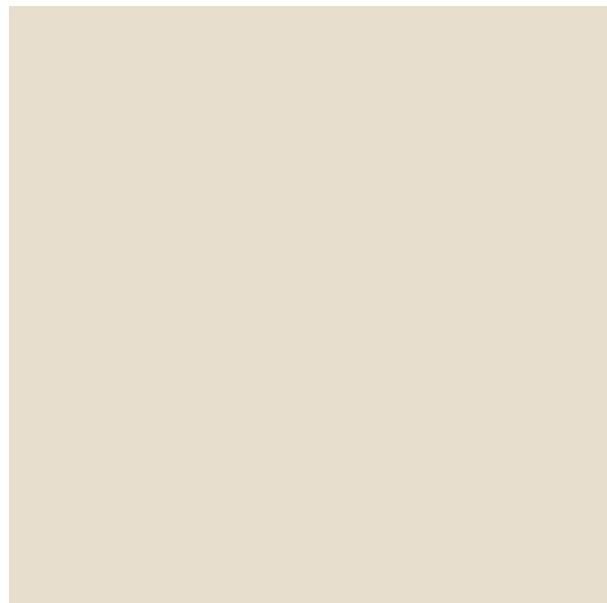
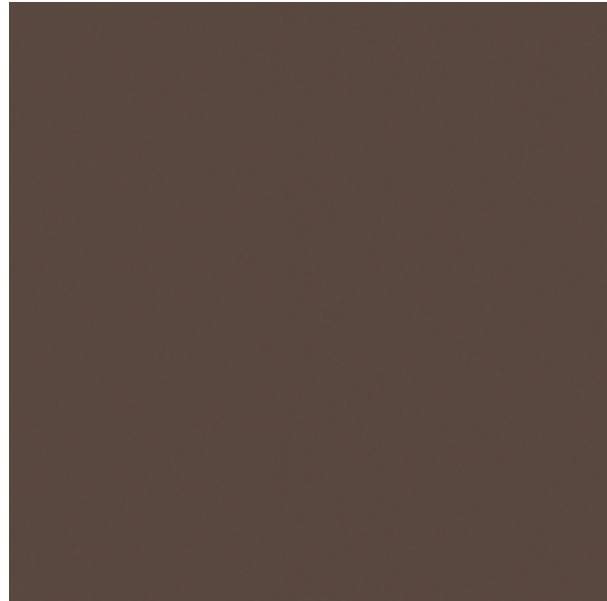

architecture dark ivory matt

architecture dark ivory gloss

architecture light ivory matt

architecture

GRANITOGRES

architecture light brown gloss



architecture beige matt



architecture beige gloss

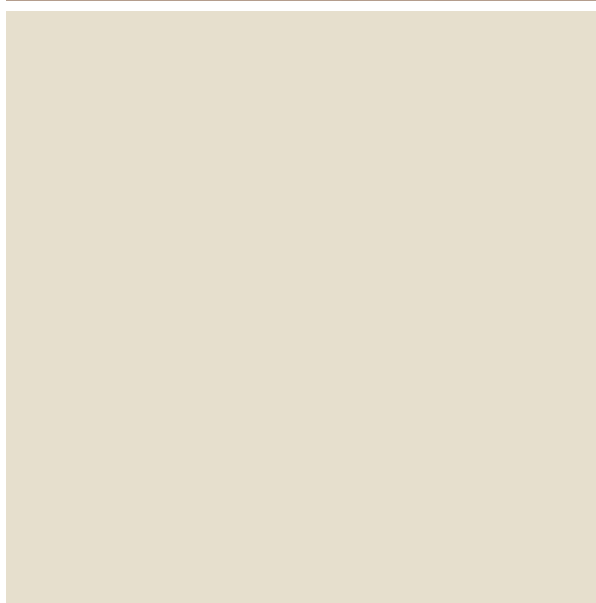

architecture light ivory gloss

architecture white matt

architecture white gloss

COLORI COLOURS COULEURS FARBEN

architecture purple matt



architecture purple gloss



architecture acid green matt



architecture acid green gloss



SUPERFICI SURFACES
SURFACES OBERFLÄCHEN

architecture

GRANITOGRES

levigata polished polie poliirt

naturale matt naturelle matt R9

gloss R9

FORMATI SIZES FORMATS FORMATE

Formati Sizes Formats Formate	cm 30x30 11 ³ / ₄ "x11 ³ / ₄ "	cm 15x60 5 ⁷ / ₈ "x23 ⁵ / ₈ "	cm 30x60 11 ³ / ₄ "x23 ⁵ / ₈ "	cm 60x60 23 ⁵ / ₈ "x23 ⁵ / ₈ "	cm 15x90 5 ⁷ / ₈ "x35 ³ / ₈ "	cm 45x90 17 ³ / ₄ "x35 ³ / ₈ "	cm 90x90 35 ³ / ₈ "x35 ³ / ₈ "	cm 60x120 23 ⁵ / ₈ "x47 ¹ / ₄ "
Superfici Surfaces Surfaces Oberflächen	● ● ●	● ● ●	● ● ●	● ● ●	● ●	● ●	● ●	● ●
▼ ▲	mm 9,4	mm 10 mm 9,4	mm 10 mm 9,4	mm 10	mm 10	mm 10	mm 10	mm 10



Stonizzazione uniforme
Shade variation uniform
Variations d'ombre uniforme
Farbtonvarianten Akzentuiert

- Naturale Matt Naturelle Matt **R9**
(A richiesta On request Sur demand Auf Anfrage **R10**)
- Gloss **R9**
- Levigata Polished Polie Poliert

Rettificate in un unico calibro Rectified version in a single caliber Rectifiés en un unique calibre Boden Sie in einem einzigen Kaliber

Nel caso di combinazioni di formati di spessori diversi, specificarlo espressamente nell'ordine

Please specify in your order if you wish to purchase formats including more than one thickness

Prière de spécifier dans votre commande si vous souhaitez acheter des formats avec différentes épaisseurs

Bitte weisen Sie im Bestellungsformular ausdrücklich darauf hin, wenn Sie Formatkombinationen mit verschiedenen Stärken wünschen

Caratteristiche tecniche e imballi a pagina: Technical features and packing on page: Caractéristiques techniques et emballages à la page: Technische Eigenschaften und Verpackungen auf Seite: **494**

PEZZI SPECIALI TRIMS ACCESSOIRES FORMSTÜCKE

Battiscopa Bullnose
Plinthe à bord arrondi
Stehsokkel
cm 9x90 - 3¹/₂"x35³/₈"
cm 9x60 - 3¹/₂"x23⁵/₈"



Gradino Step tread
Nez de marche Stufenplatte
cm 30x60 - 11³/₄"x23⁵/₈"

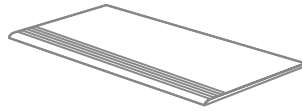

Gradone (assemblato)
cm 60x33 - 23⁵/₈"x13"

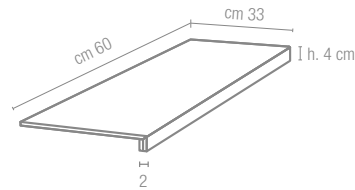

Angolare (assemblato)
cm 60x33 - 23⁵/₈"x13"

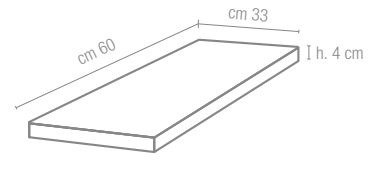

architecture white,
architecture black
cm 30x60 - 11³/₄"x23⁵/₈"



DECORI DECORS DÉCORS DEKORE

architecture

GRANITOGRES

**mix listelli
architecture A**

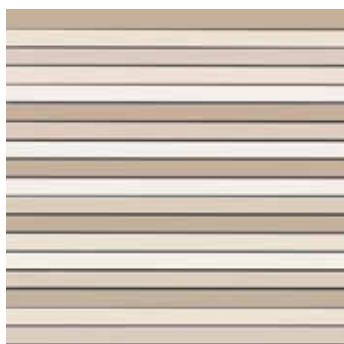

cm 30x30 - 11³/₄"x11³/₄"
listello **cm 1,4x30 - 1/2"x11³/₄"**
su rete on net sur trame auf Netz
beige, dark ivory, light ivory, white
naturale matt naturelle matt

**mix listelli
architecture B**



cm 30x30 - 11³/₄"x11³/₄"
listello **cm 1,4x30 - 1/2"x11³/₄"**
su rete on net sur trame auf Netz
medium grey, dark grey, black
naturale matt naturelle matt

**mix listelli
architecture C**

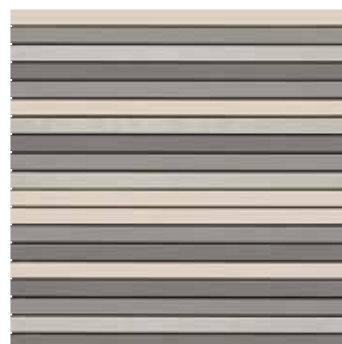

cm 30x30 - 11³/₄"x11³/₄"
listello **cm 1,4x30 - 1/2"x11³/₄"**
su rete on net sur trame auf Netz
warm grey, cool grey, light grey, medium grey
naturale matt naturelle matt

**mix listelli
architecture D**

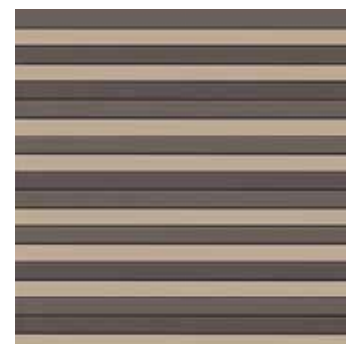

cm 30x30 - 11³/₄"x11³/₄"
listello **cm 1,4x30 - 1/2"x11³/₄"**
su rete on net sur trame auf Netz
beige, dark brown, light brown
naturale matt naturelle matt

mix listelli*



cm 30x30 - 11³/₄"x11³/₄"
listello **cm 1,4x30 - 1/2"x11³/₄"**
su rete on net sur trame auf Netz

* Disponibile in tutti i colori della serie
Available in all the colours of the series
Disponibile dans tous les couleurs de la série
Verfügbar in allen Farben
Listelli in superficie gloss e naturale
Listellos in gloss and matt surface
Listelli en surface naturelle et gloss
Listelli Gloss und Natur Oberfläche



**mix listelli
architecture dark brown
cm 30x30 - 11³/₄"x11³/₄",
architecture dark ivory matt
cm 60x60 - 23⁵/₈"x23⁵/₈"**

DECORI DECORS DÉCORS DEKORE

mosaico
architecture A



cm 30x30 - 11³/₄"x11³/₄"
tessera **cm 1x1** - ³/₈"x³/₈"
su rete on net sur trame auf Netz
beige, dark ivory,
light ivory, white

mosaico
architecture B

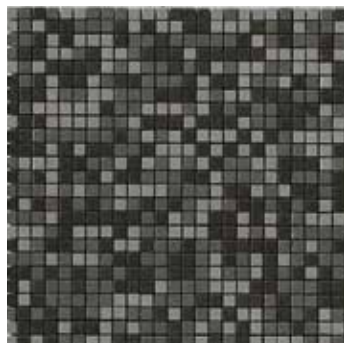

cm 30x30 - 11³/₄"x11³/₄"
tessera **cm 1x1** - ³/₈"x³/₈"
su rete on net sur trame auf Netz
medium grey,
dark grey, black

mosaico
architecture C

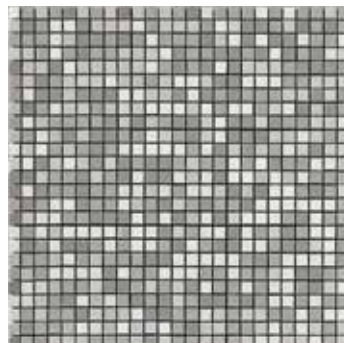

cm 30x30 - 11³/₄"x11³/₄"
tessera **cm 1x1** - ³/₈"x³/₈"
su rete on net sur trame auf Netz
warm grey, cool grey,
light grey, white

mosaico
architecture D



cm 30x30 - 11³/₄"x11³/₄"
tessera **cm 1x1** - ³/₈"x³/₈"
su rete on net sur trame auf Netz
beige, dark brown,
light brown

mosaico
architecture E

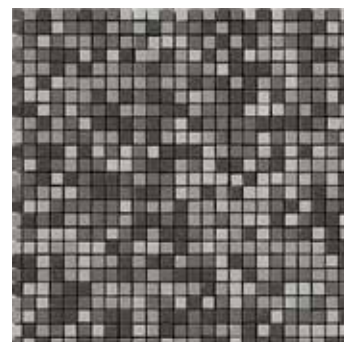

cm 30x30 - 11³/₄"x11³/₄"
tessera **cm 1x1** - ³/₈"x³/₈"
su rete on net sur trame auf Netz
dark grey, medium grey,
light grey, cool grey

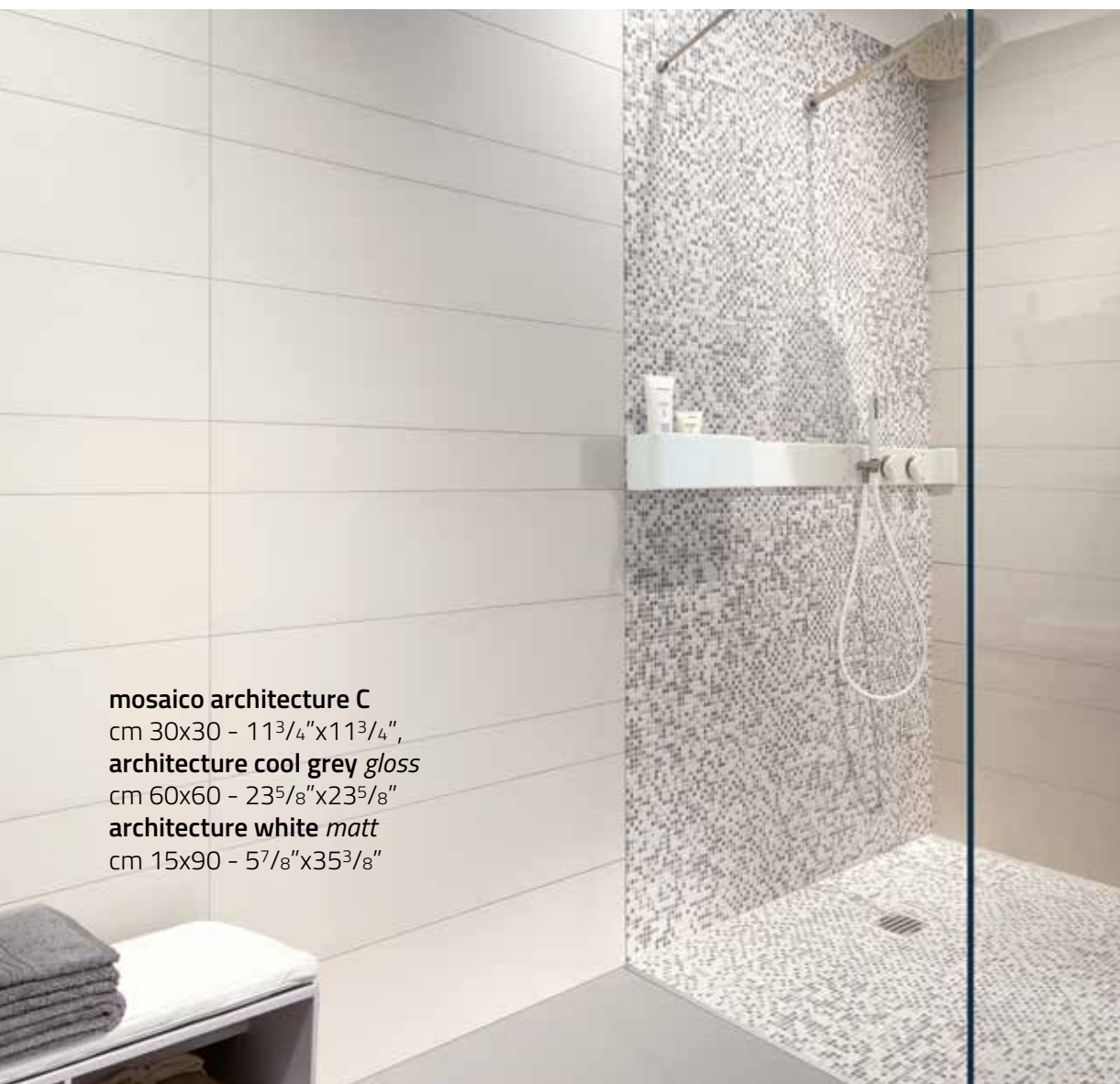

mosaico architecture C
cm 30x30 - 11³/₄"x11³/₄",
architecture cool grey gloss
cm 60x60 - 23⁵/₈"x23⁵/₈"
architecture white matt
cm 15x90 - 5⁷/₈"x35³/₈"

architecture

GRANITOGRES

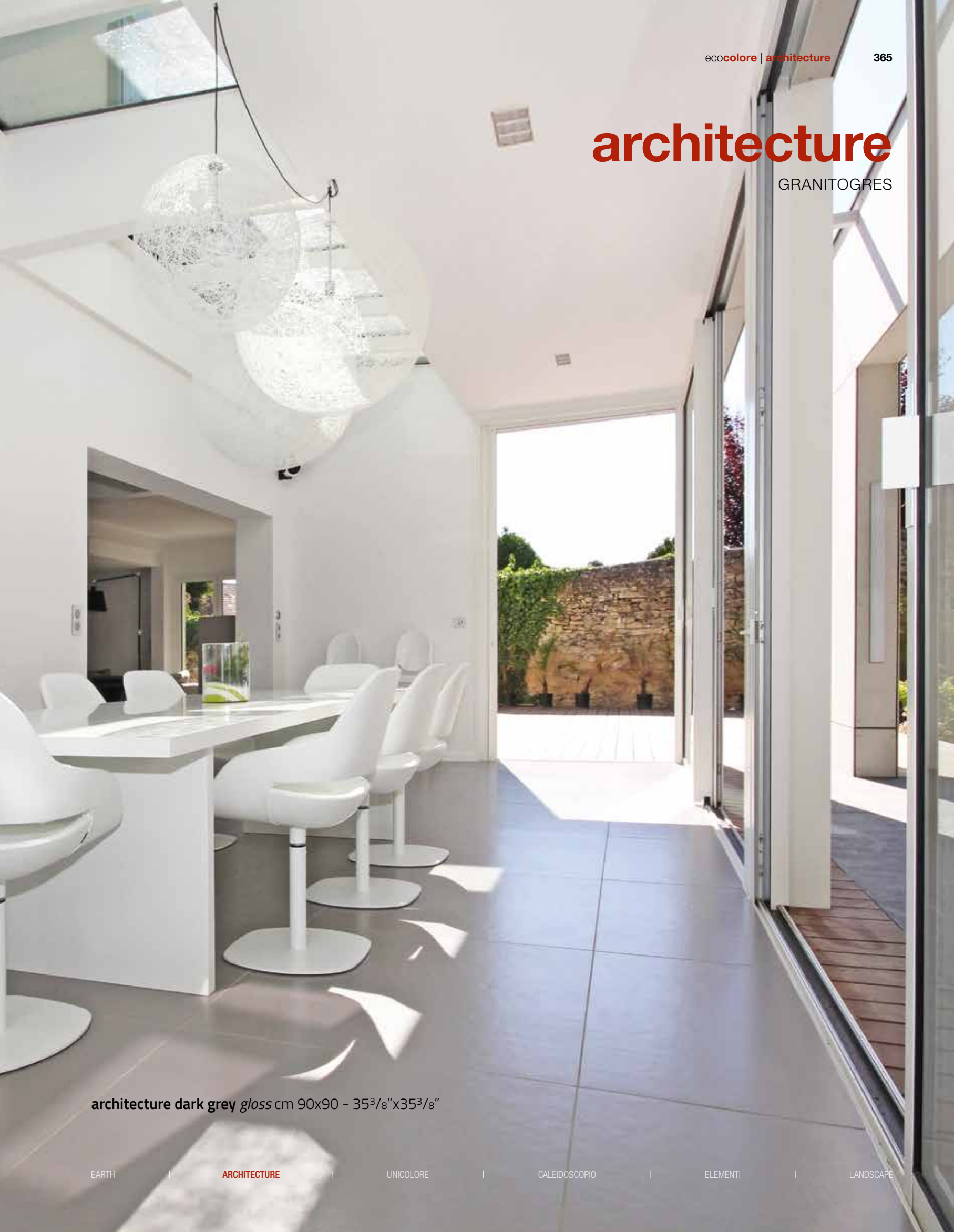

architecture dark grey gloss cm 90x90 - 35³/₈"x35³/₈"

unicolore

GRANITOGRES

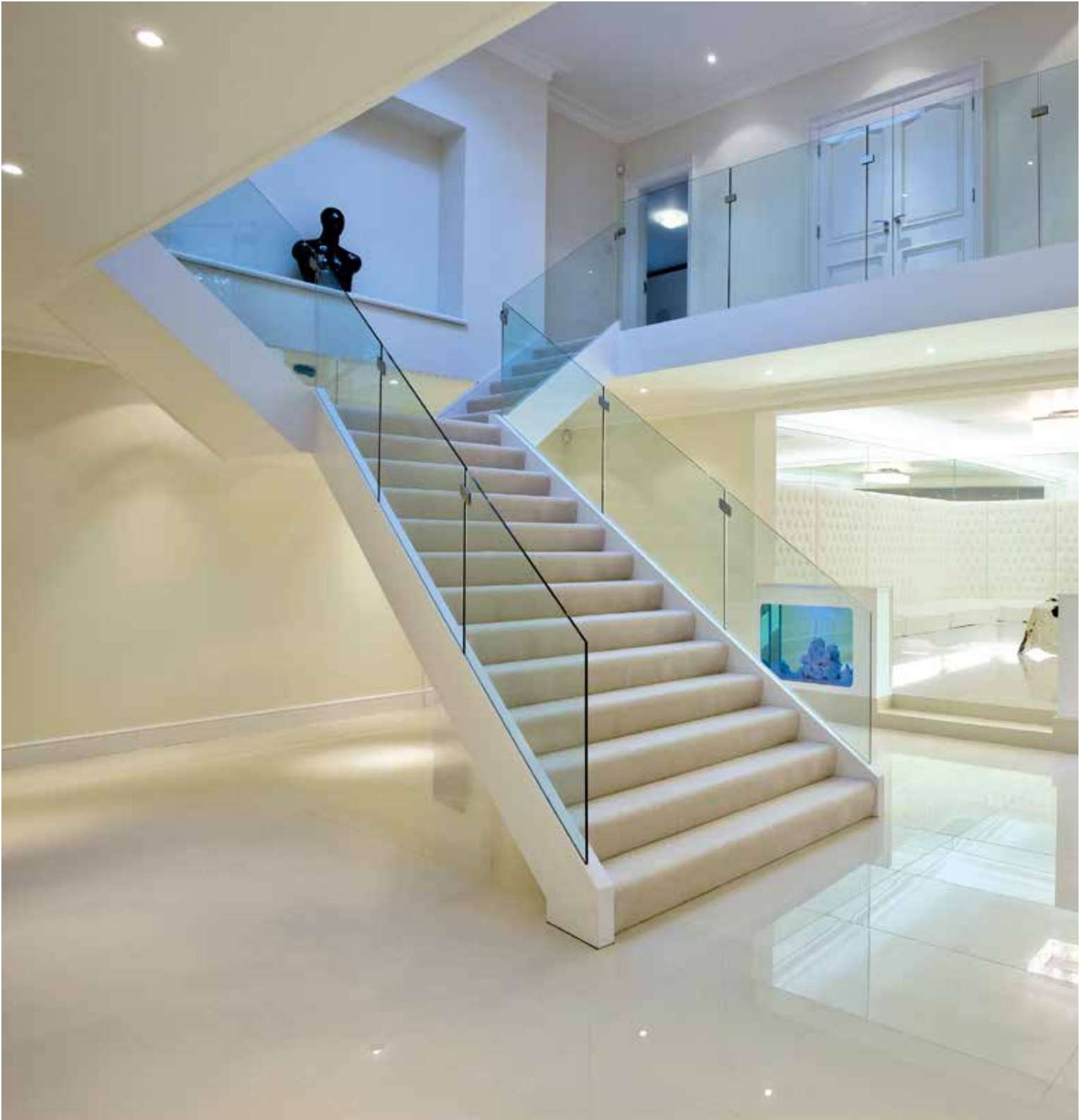

bianco assoluto *levigato polished* cm 60x60 - 23⁵/₈"x23⁵/₈", 60x120 - 23⁵/₈"x47¹/₄"

COLORI COLOURS COULEURS FARBEN

nero



grigio cenere



grigio perla



violet



blu forte



blu



unicolore

GRANITOGRES

bianco avorio



bianco B



bianco assoluto



verde



grigio azzurro



acquamarina

COLORI COLOURS COULEURS FARBEN

rosso pompeii



rosa antico



rosso mattone



giallo ocra



SUPERFICI SURFACES
SURFACES OBERFLÄCHEN









unicolore

GRANITOGRES

levigata polished polie poliirt

naturale matt naturelle matt R9 A

FORMATI SIZES FORMATS FORMATE

Formati Sizes Formats Formate	 cm 10x20 4"x7 ⁷ / ₈ "	 cm 20x20* 7 ⁷ / ₈ "x7 ⁷ / ₈ "	 cm M 12,5x25*** 4 ⁷ / ₈ "x9 ⁷ / ₈ "	 cm 30x30 11 ³ / ₄ "x11 ³ / ₄ "	 cm 40x40 15 ³ / ₄ "x15 ³ / ₄ "	 cm 30x60** 11 ³ / ₄ "x23 ⁵ / ₈ "	 cm 60x60** 23 ⁵ / ₈ "x23 ⁵ / ₈ "	 cm 60x120** 23 ⁵ / ₈ "x47 ¹ / ₄ "
Acquamarina		●		● ●	● ●			
Bianco Assoluto		●		● ●	● ●	● ●	● ●	● ●
Bianco Avorio	●	● ●	● ●	● ● ●	● ●			● ●
Bianco B	●	● ●	● ●	● ● ●	● ●	● ●	● ●	● ●
Blu		●		● ●	● ●			
Blu Forte		●		● ●	● ●			
Giallo Ocra		●		● ●	● ●			
Grigio Azzurro		●		● ●	● ●			
Grigio Cenere		● ●		● ● ●	● ●			
Grigio Perla		●		● ●	● ●			
Nero		●		● ●	● ●			
Rosa Antico		●		● ●	● ●			
Rosso Mattone		●		● ●	● ●			
Rosso Pompei		●		● ●	● ●			
Verde		●		● ●	● ●			
Violet		●		● ●	● ●			
 *	mm 8	mm 8	mm 8	mm 8	mm 9	mm 10 mm 9♦	mm 10	mm 10



Stonilizzazione uniforme
Shade variation uniform
Variations d'ombre uniforme
Farbtonvarianten Akzentuiert

● Naturale Matt Naturelle Matt **R9 A**
● Levigata Polished Polie Poliert
● Technic **R10**

* Spessore su superficie naturale Thickness on matt surface Épaisseur sur surface naturelle Stärke der Fliesen mit Mattoberfläche

** Rettificate in un unico calibro Rectified version in a single caliber Rectifiés en un unique calibre Boden Sie in einem einzigen Kaliber

*** Misure di fabbricazione: Cotes de fabrication: Worksizes: Herstellmasse: **cm 11,8x24,3**

♦ Solo **Bianco Assoluto** Only **Bianco Assoluto** Seulement **Bianco Assoluto** Nur **Bianco Assoluto**

Per superfici speciali antiscivolo e spessori maggiorati vedere catalogo Technic For increased thicknesses and special no-slip surfaces see the Technic catalogue
Pour des surfaces antiderapantés et les épaisseurs majorés, voir catalogue Technic Für sonderrutschhemmende Oberflächen und Stärken siehe Kataloge Technic

Caratteristiche tecniche e imballi a pagina: Technical features and packing on page: Caractéristiques techniques et emballages à la page: Technische Eigenschaften und Verpackungen auf Seite: **494**

PEZZI SPECIALI TRIMS ACCESSOIRES FORMSTÜCKE

unicolore

GRANITOGRES

Battiscopa Bullnose
Plinthe à bord arrondi
Stehsokkel
cm 9x30 - 3½"x11¾"
cm 9x40 - 3½"x15¾"
cm 10x20 - 4"x7⅞"

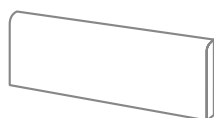

Zoccolo a raccordo a taglio retto*
Cove base - straight top*
Plinthe à gorge avec bord vif*
Hohlkehlsokkel (scharfkantig)*
cm 10x20 - 4"x7⅞"

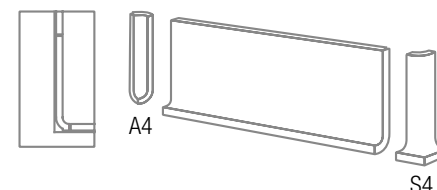

Gradino Step tread
Nez de marche Stufenplatte
cm 30x30 - 11¾"x11¾"

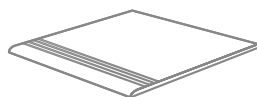

Zoccolo ad appoggio smussato*
Sit-on skirting - bevelled top*
Plinthe à talon avec bord arrondi*
Aufsetzsockel mit abgerundeter Kante*
cm 10x20 - 4"x7⅞"

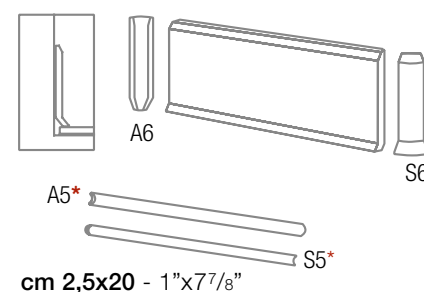

Listello Listel
Listel Zeierleiste
cm 9x30 - 3½"x11¾"
cm 9x40 - 3½"x15¾"



Tozzetto Insert
Cabochon Einleger
cm 9x9 - 3½"x3½"

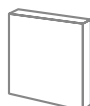

Sguscetta* Cove*
Gorge* Rinnleiste*
cm 4x20 - 1⅝"x7⅞"

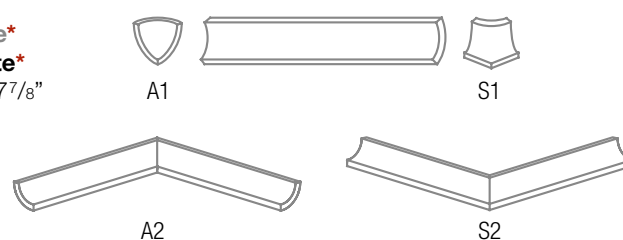

* Produzione corrente solo nei colori: Currently produced only in the following colours:
Productions courantes seulement dans les couleurs: Actuelle Produktion nur in den Farben:
Bianco Avorio, Bianco B

Altri colori sono prodotti solo su richiesta Other colours are produced on demand Autres teintes disponibles sur demand Andere Farben nur auf Antrag



grigio cenere cm 30x30 - 11¾"x11¾"

caleidoscopio

ECOGRES



pistacchio, caffè cm 20x20 - 7⁷/₈"x7⁷/₈"

COLORI COLOURS COULEURS FARBEN

liquirizia



caffè



oceano



smeraldo



oliva



pistacchio

caleidoscopio

ECOGRES

cobalto



marina

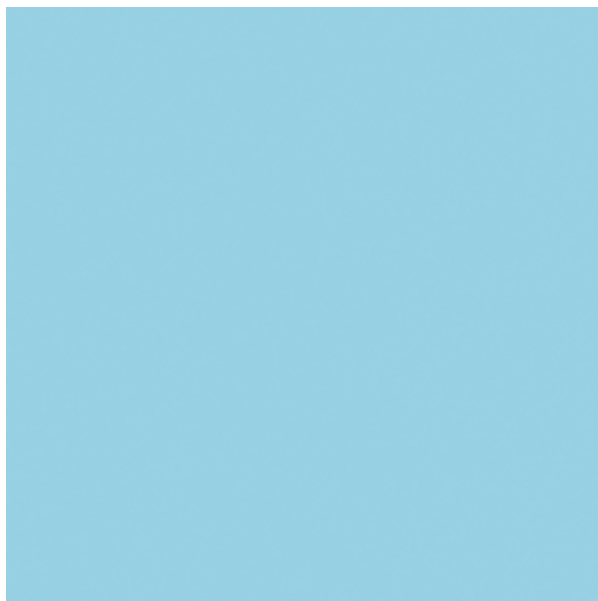

anice

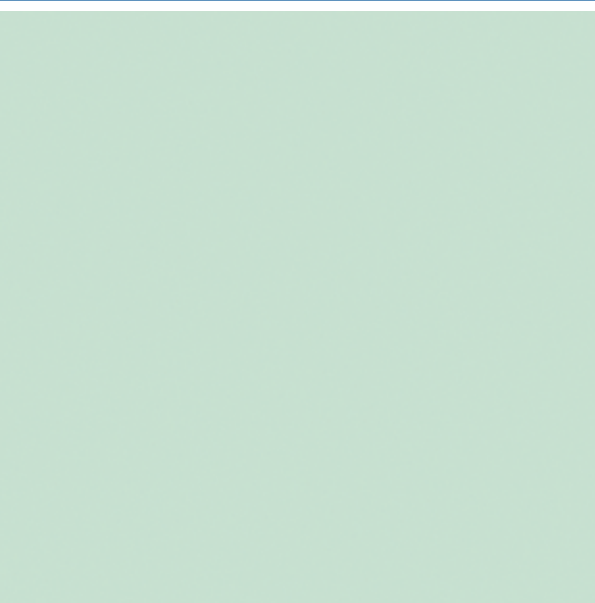
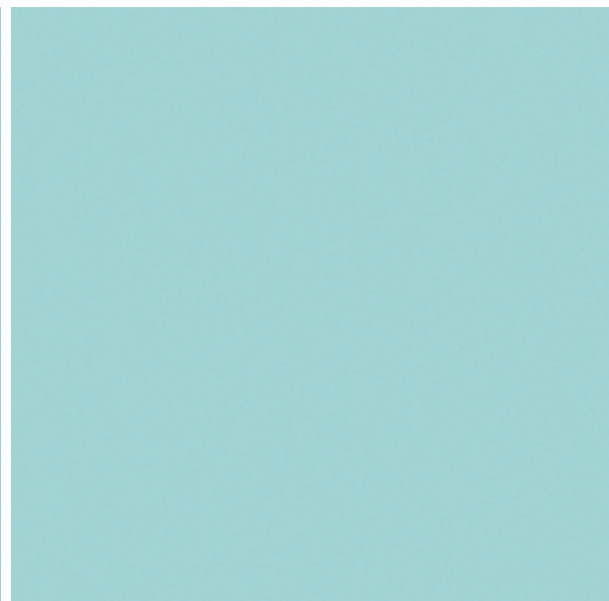

menta

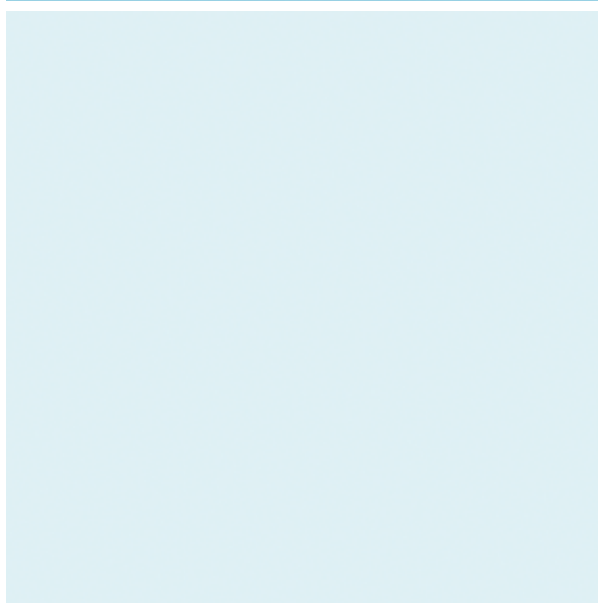

cielo

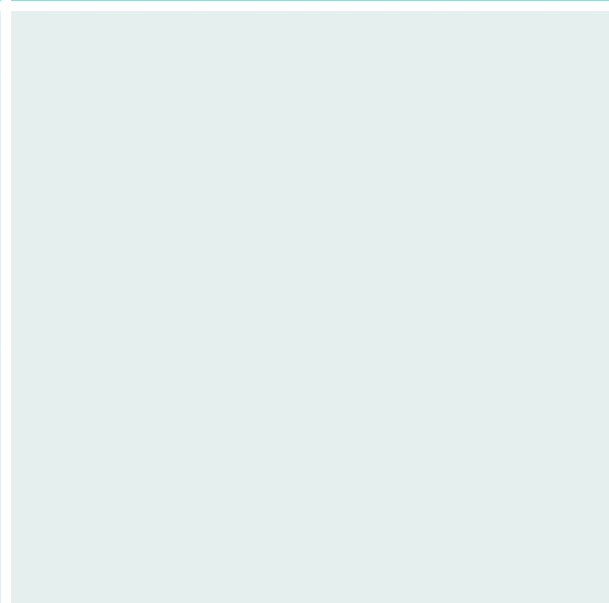

pack

COLORI COLOURS COULEURS FARBEN

rosso selenio



corallo



ocra

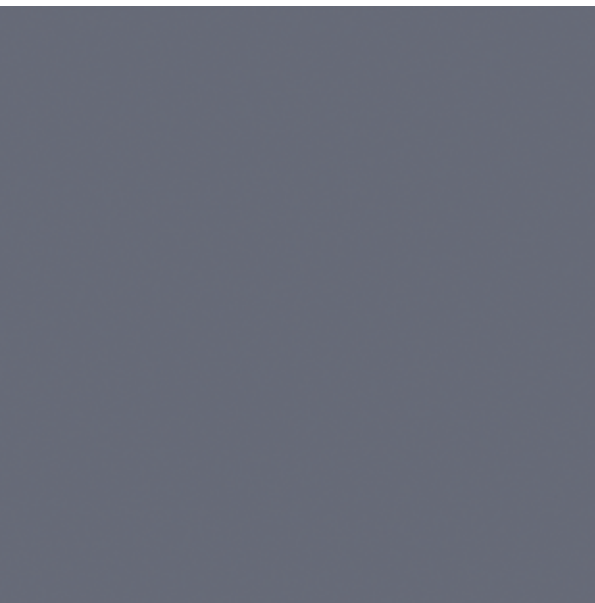

antracite



granita

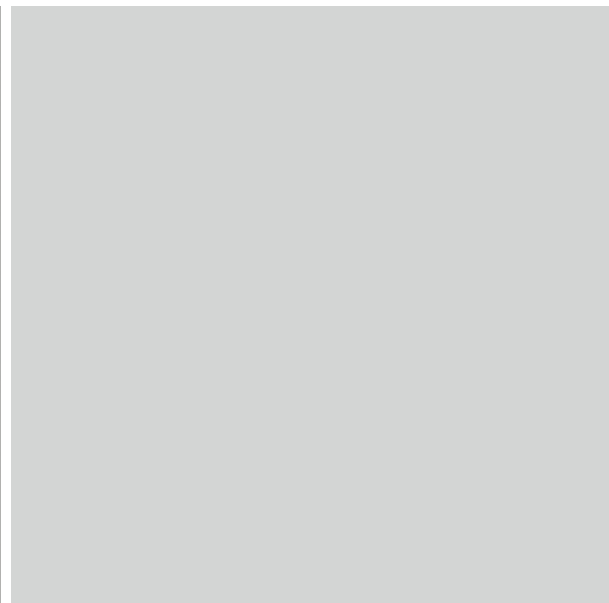

ghiaccio

caleidoscopio

ECOGRES

caramel



fragola



panna

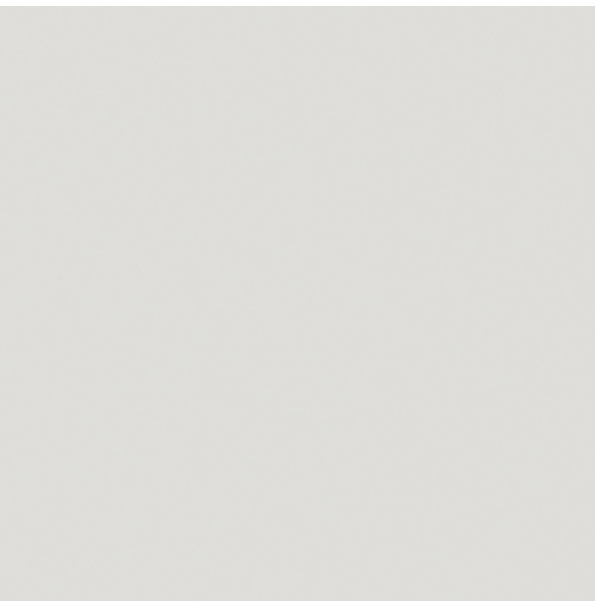
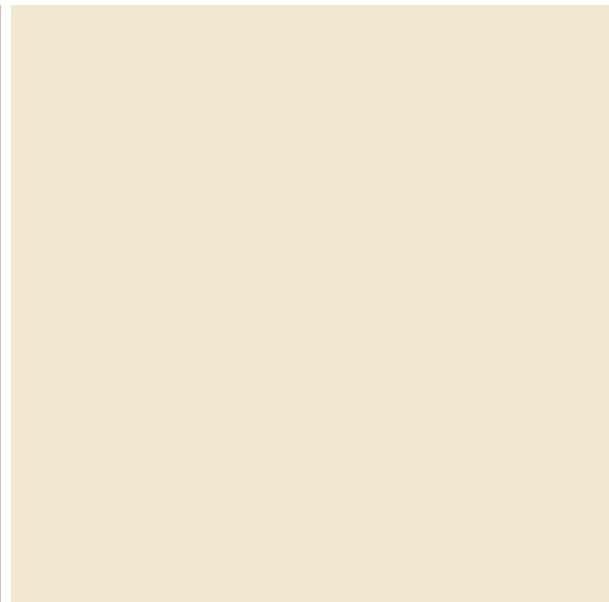

betulla

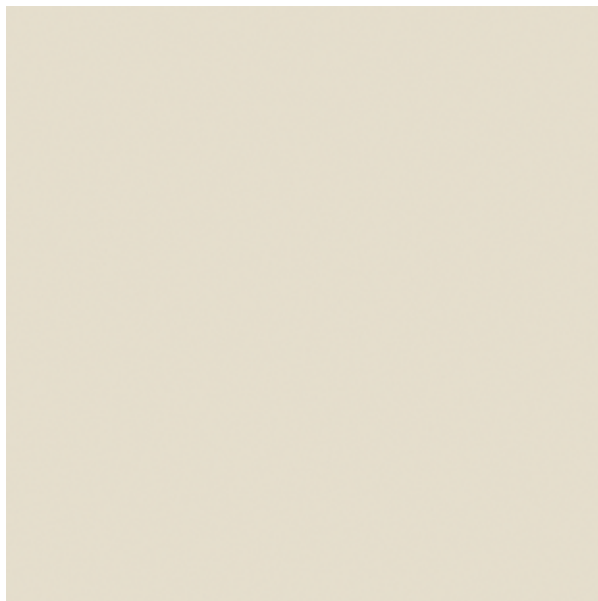

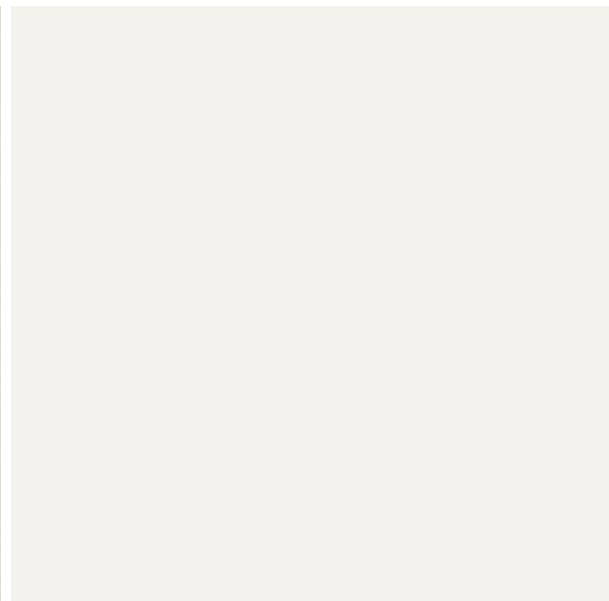

avorio



cocco

FORMATI SIZES FORMATS FORMATE

Formati Sizes Formats Formate		 cm 20x20 7 ⁷ / ₈ "x7 ⁷ / ₈ "	 cm 33x33 13"x13"
Anice	G3*	● ●	
Antracite	G3*	●	●
Avorio	G3*	●	
Betulla	G3*	● ●	
Caffè	G2*	●	
Caramel	G3*	●	
Cielo	G3**	●	
cobalto	G3*	●	
Cocco	G3*	●	●
Corallo	G3*	●	
Fragola	G3*	●	
Ghiaccio	G3*	●	
		mm 7,3	mm 8,2



Formati Sizes Formats Formate		 cm 20x20 7 ⁷ / ₈ "x7 ⁷ / ₈ "
Granita	G3*	● ●
Liquirizia	G2*	●
Marina	G3*	●
Menta	G3*	●
Oceano	G2*	●
Ocra	G3*	●
Oliva	G2*	●
Pack	G3*	●
Panna	G3*	●
Pistacchio	G2*	●
Rosso selenio	G2*	●
Smeraldo	G2*	●
		mm 7,3

● Naturale Matt Naturelle Matt
● Grip R10

* Vedi pagina: See page: Voir page Siehe Seite: **503**

Rettificate in un unico calibro Rectified version in a single caliber Rectifiés en un unique calibre Boden Sie in einem einzigen Kaliber

Caratteristiche tecniche e imballi a pagina: Technical features and packing on page: Caractéristiques techniques et emballages à la page: Technische Eigenschaften und Verpackungen auf Seite: **506**

PEZZI SPECIALI TRIMS ACCESSOIRES FORMSTÜCKE

Battiscopa* Bullnose*
Plinthe à bord arrondi*
Stehsokkel*
cm 8x33 - 3¹/₂"x11³/₄"



Sguscetta* Cove*
Gorge* Rinneleiste*
cm 2,5x20 - 1"x7⁷/₈"



Conchiglia*



Piè d'oca*



* Produzione corrente solo nei colori: Currently produced only in the following colours: Productions courantes seulement dans les couleurs: Aktuelle Produktion nur in den Farben: **Betulla, Cocco**

DECORI DECORS DÉCORS DEKORE

matita**



cm 2x20 - 3³/₄"x7⁷/₈"

london**



cm 3x20 - 1¹/₈"x7⁷/₈"

spigolo**



** Disponibile nei colori: Available in the colours: Disponible dans les couleurs: Verfügbar in den folgenden Farben:
Anice, Caramel, Cobalto, Fragola, Granita, Marina, Menta, Pack, Smeraldo

SUPERFICI SURFACES
SURFACES OBERFLÄCHEN

caleidoscopio
ECOGRES

naturale matt naturelle matt

grip R10

elementi

GRANITOGRES



alga 050 , avorio 011 cm 12,5x25 - 5"x10"

COLORI COLOURS COULEURS FARBEN

talco 010



avorio 011



cemento 060

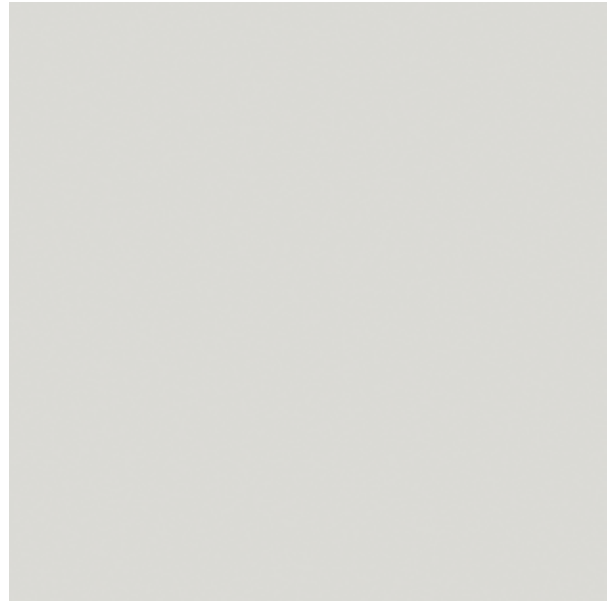

alga 050



pino 051



sabbia 030



elementi

GRANITOGRES

onda 020



mare 021



basalto 061



ebano 070

FORMATI SIZES FORMATS FORMATE

	□ 1120	□□ 1121 break	□ 1100	□ 1000
Formati Sizes Formats Formate	cm M* 12,5x12,5 4 ⁷ / ₈ "x4 ⁷ / ₈ "	cm M* 12,5x12,5 2 pc 4 ⁷ / ₈ "x4 ⁷ / ₈ "	cm M* 12,5x25 4 ⁷ / ₈ "x9 ⁷ / ₈ "	cm M* 25x25 9 ⁷ / ₈ "x9 ⁷ / ₈ "
Talco 010	● ● ●	●	● ● ●	● ● ●
Cemento 060			● ●	● ● ●
Basalto 061			● ●	
Sabbia 030			● ●	
Ebano 070			● ●	● ●
Avorio 011	● ● ●	●	● ● ●	● ● ●
Onda 020	● ●	●	● ●	● ● ●
Mare 021	● ● ●		● ● ●	● ● ●
Alga 050			● ●	● ●
Pino 051			● ●	
▽ ▲	mm 8	mm 8	mm 8	mm 8

	Misure nominali Nominal sizes Cotes nominales Nennmasse		Misure di fabbricazione Workside Cotes de fabricatio Herstellmasse		
1120	cm M* 12,5x12,5	M* 4⁷/₈"x4⁷/₈"	mm 118x118	4⁵/₈"x4⁴/₆₄"	● Matt
1121 break**	cm M* 12,5x12,5	M* 4⁷/₈"x4⁷/₈" x 2 pc	mm 118x118	4⁵/₈"x4⁵/₈" x 2 pc	● Pinhead
1100	cm M* 12,5x25	M* 4⁷/₈"x9⁷/₈"	mm 118x243	9⁹/₁₆"x9⁹/₁₆"	● Roccia
1000	cm M* 25x25	M* 9⁷/₈"x9⁷/₈"	mm 243x243	9⁹/₁₆"x9⁹/₁₆"	● Rigata/Cannelé

* M= formato modulare modular size format modulaire modulformat

** Da separare in cantiere A break on job site À séparer en chantier Spaltplatten auf Baustelle zuberechen

Importante: la modularità dei formati si ottiene con fuga di 7 mm Important: modularity of different sizes is based on 7 mm grouting joints
Important: la modularité des formats est calculée avec un joint de 7 mm Wichtig: Für Modulverlegung die empfohlene Fugenbreite ist 7 mm

Caratteristiche tecniche e imballi a pagina: Technical features and packing on page: Caractéristiques techniques et emballages à la page: Technische Eigenschaften und Verpackungen auf Seite: 494

SUPERFICI SURFACES SURFACES OBERFLÄCHEN



●
Matt

DIN 51097 B	XP P 05-010 PN 18	
DIN 51130 R 10 V	XP P 05-010 PC 10	



●
Pinhead

DIN 51097 C	XP P 05-010 PN 24	
DIN 51130 R 12 V 6	XP P 05-010 PC 20	



●
Roccia

DIN 51097 C	XP P 05-010 PN 24	
DIN 51130 R 12 V 6	XP P 05-010 PC 27	



●
Rigata
Cannelé

DIN 51097 C	XP P 05-010 PN 24	
DIN 51130 R 12 V	XP P 05-010 PC 27	

elementi

GRANITOGRES

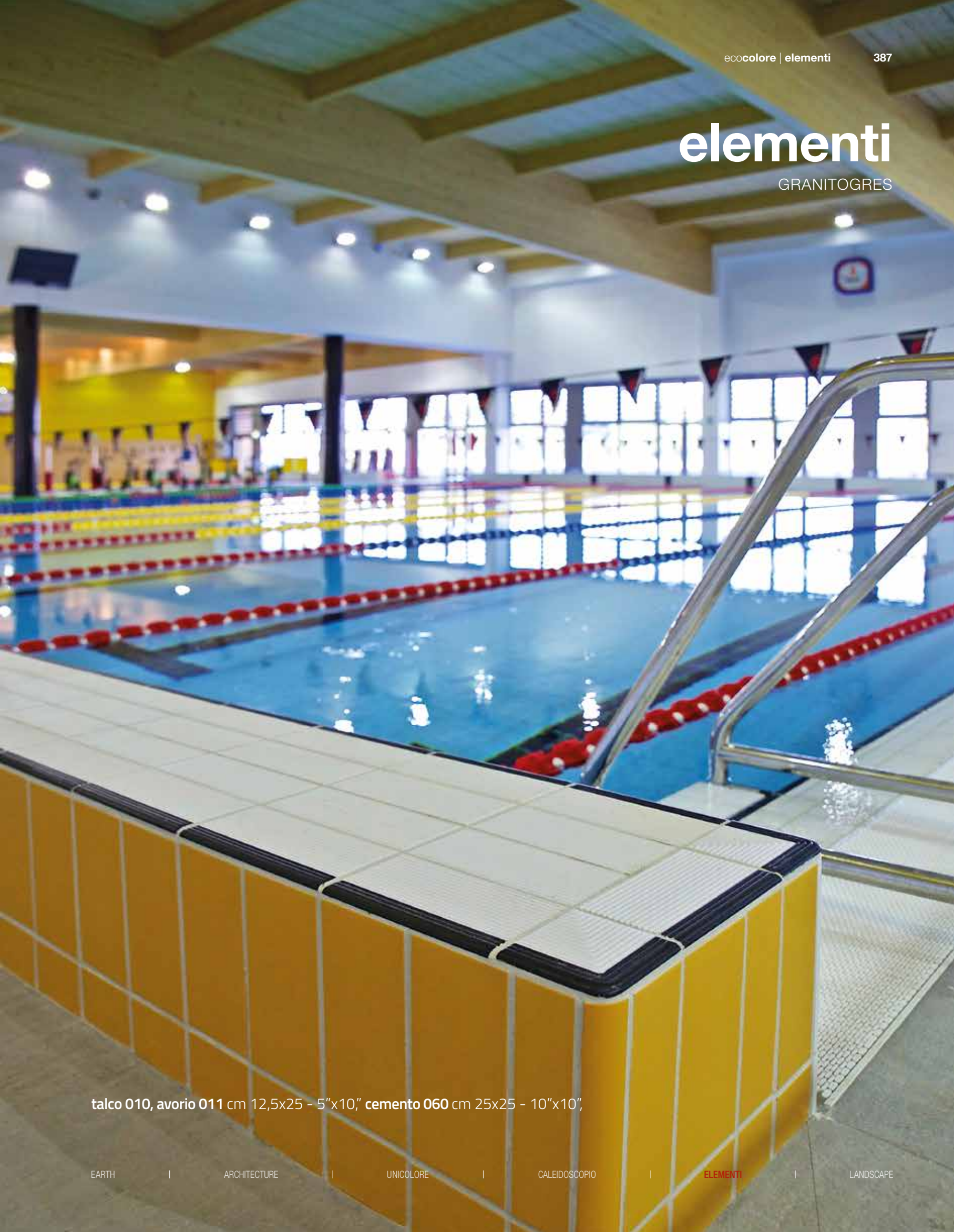

talco 010, avorio 011 cm 12,5x25 - 5"x10," cemento 060 cm 25x25 - 10"x10,"

landscape

GRESPLUS



tundra 100, baltic 201, lagoon 502, dune 300, sunset 400 cm 12,5x25 - 5"x10"

COLORI COLOURS COULEURS FARBEN

tundra 100



bay 200



beach 101



caribe 500



lagoon 502



lava 700

landscape

GRESPLUS

ocean 202



baltic 201



bahama 501

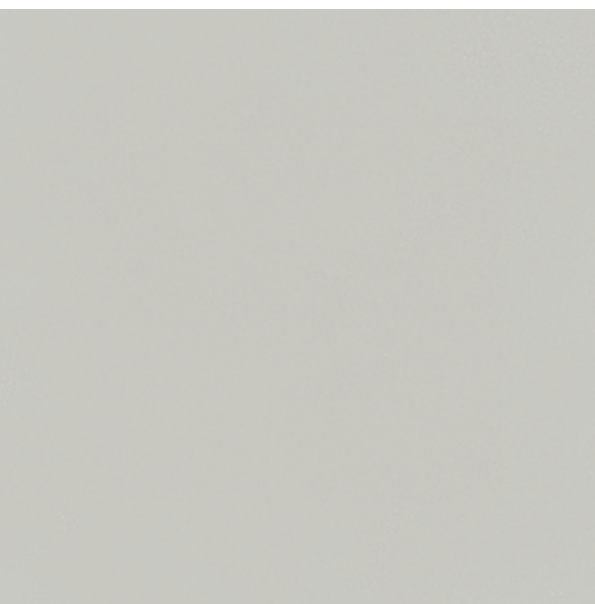

artic 701





































dune 300



sunset 400

FORMATI SIZES FORMATS FORMATE

	 1120	 1121 break	 2100	 1100	 1000
Formati Sizes Formats Formate	cm M* 12,5x12,5 4 ⁷ / ₈ "x4 ⁷ / ₈ "	cm M* 12,5x12,5 2 pc 4 ⁷ / ₈ "x4 ⁷ / ₈ "	cm M* 6,25x25 2 ¹ / ₂ "x9 ⁷ / ₈ "	cm M* 12,5x25 cm 4 ⁷ / ₈ "x9 ⁷ / ₈ "	cm M 25x25 9 ⁷ / ₈ "x9 ⁷ / ₈ "
Tundra 100					
Beach 101					
Bay 200					
Baltic 201					
Ocean 202					
Artic 701					
Bahama 501					
Caribe 500					
Lava 700					
Dune 300					
Lagoon 502					
Sunset 400					
	mm 8	mm 8	mm 8	mm 8	mm 8

	Misure nominali Nominal sizes Cotes nominales Nennmasse	Misure di fabbricazione Workside Cotes de fabricatio Herstellmasse	
1120	cm M* 12,5x12,5 M* 4 ⁷ / ₈ "x4 ⁷ / ₈ "	mm 118x118 4 ⁵ / ₈ "x4 ⁵ / ₈ "	<ul style="list-style-type: none">  Lucida  Satin  Friction  Grip  Rigata/Cannelé
1121 break**	cm M* 12,5x12,5 M* 4 ⁷ / ₈ "x4 ⁷ / ₈ "	mm 118x118 4 ⁵ / ₈ "x4 ⁵ / ₈ "	
2100	cm M* 12,5x12,5 M* 4 ⁷ / ₈ "x4 ⁷ / ₈ " x 2 pc	mm 118x118 4 ⁵ / ₈ "x4 ⁵ / ₈ " x 2 pc	
1100	cm M* 6,25x25 M* 2 ¹ / ₂ "x9 ⁷ / ₈ "	mm 55,5x243 2 ³ / ₁₆ "x9 ⁹ / ₁₆ "	
100	cm M* 12,5x25 M* 4 ⁷ / ₈ "x9 ⁷ / ₈ "	mm 118x243 4 ⁵ / ₈ "x9 ⁹ / ₁₆ "	
1120	cm M* 25x25 M* 9 ⁷ / ₈ "x9 ⁷ / ₈ "	mm 243x243 9 ⁹ / ₁₆ "x9 ⁹ / ₁₆ "	

* M= formato modulare modular size format modulaire modulformat

** Da separare in cantiere A break on job site À séparer en chantier Spaltplatten auf Baustelle zubereiten

Importante: la modularità dei formati si ottiene con fuga di 7 mm Important: modularity of different sizes is based on 7 mm grouting joints
Important: la modularité des formats est calculée avec un joint de 7 mm Wichtig: Für Modulverlegung die empfohlene Fugenbreite ist 7 mm

Caratteristiche tecniche e imballi a pagina: Technical features and packing on page: Caractéristiques techniques et emballages à la page: Technische Eigenschaften und Verpackungen auf Seite: **504**

tundra 100, ocean 202, bay 200 cm 25x25 - 10"x10"



landscape

GRESPLUS

SUPERFICI SURFACES SURFACES OBERFLÄCHEN

DECORI DECORS DÉCORS DEKORE

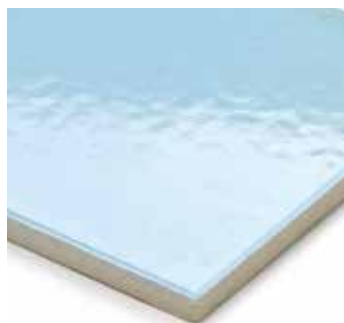

●
Lucida



●
Friction

DIN 51097 XP P 05-010
B PN 18

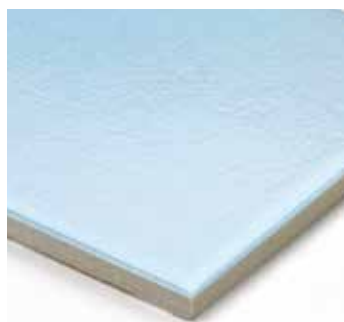

●
Satin

DIN 51097 XP P 05-010
A PN 12



●
Grip

DIN 51097 XP P 05-010
C PN 24



●
Rigata
Cannelé

DIN 51097 XP P 05-010 DIN 51130
C PN 24 V 8

LS mix 810

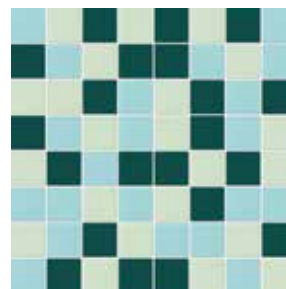

cm M 25x25 - 10"x10"
Satin
Bahama 501, Caribe 500,
Lagoon 502

LS mix 830

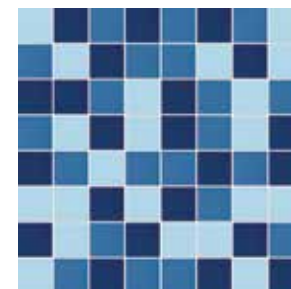

cm M 25x25 - 10"x10"
Satin
Bay 200, Baltic 201,
Ocean 202

LS mix 820

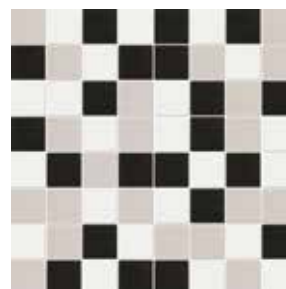

cm M 25x25 - 10"x10"
Satin
Tundra 100, Lava 700,
Artic 701

LS uni bay

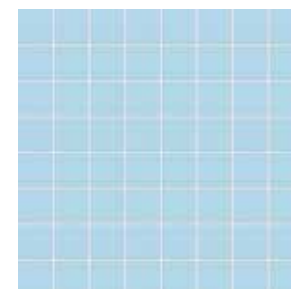

cm M 25x25 - 10"x10"
Satin

LS uni ocean

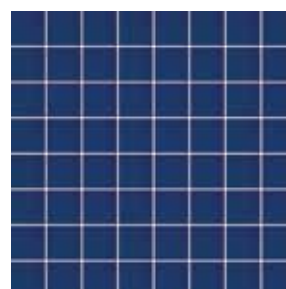

cm M 25x25 - 10"x10"
Satin

LS uni tundra

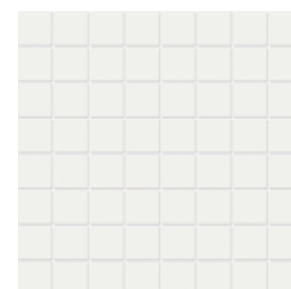

cm M 25x25 - 10"x10"
Satin

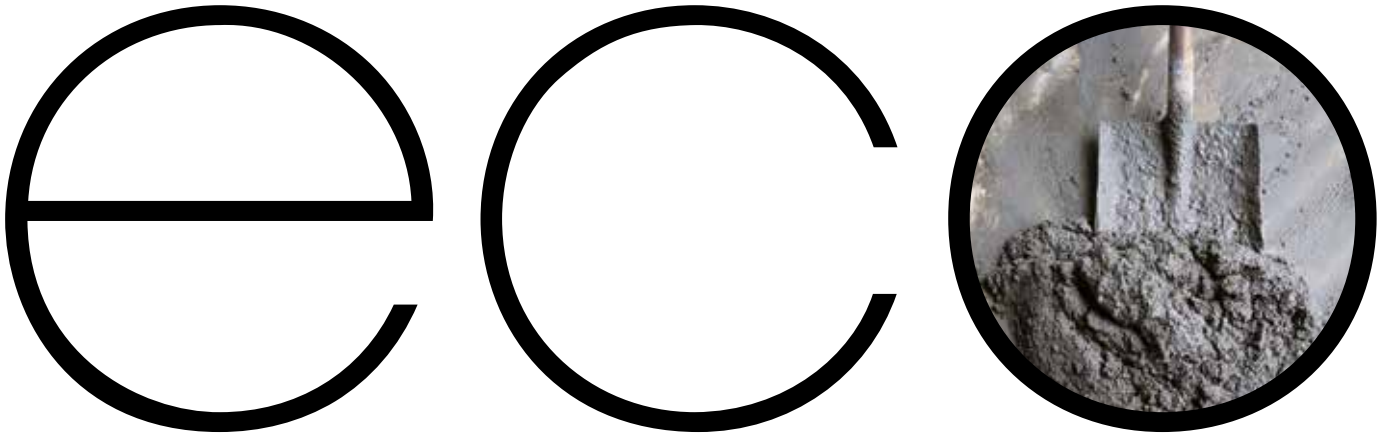

eco**concrete** éco**ciment** öko**zement**

cemento

eco**cemento**

398 **manhattan**

404 **r-evolution**

410 **beton**

422 **cemento**

432 **resina**

440 **spazio**

446 **econcrete**

450 **opus**

460 **città**

464 **feel**

468 **living**

501

CEMENTO

Composto di silicati e alluminati di calcio ottenuto attraverso la cottura a elevata temperatura di calcare e argilla o di marna. La materia prima risultante viene macinata e addizionata con altri componenti per specializzarne le prestazioni in funzione dell'impiego. Miscelato con acqua, si idrata e solidifica progressivamente.

CONCRETE

Composed of silicates and calcium aluminates, made by cooking limestone and clay or marl at high temperatures. The resulting material is crushed and mixed with other ingredients to make it perform according to its intended use. Mixed with water, it progressively gets hydrated and sets.

84



manhattan

GRANITOKER



soho cm 90x90 - 35³/₈"x35³/₈"

COLORI COLOURS COULEURS FARBEN

soho



tribeca



queens















harlem

manhattan

GRANITOKER

queens cm 90x90 - 35³/₈"x35³/₈"

FORMATI SIZES FORMATS FORMATE

Formati Sizes Formats Formate	 cm 30x60 11 ³ / ₄ "x23 ⁵ / ₈ "	 cm 60x60 23 ⁵ / ₈ "x23 ⁵ / ₈ "	 cm 45x90 17 ³ / ₄ "x35 ³ / ₈ "	 cm 90x90 35 ³ / ₈ "x35 ³ / ₈ "
Superfici Surfaces Surfaces Oberflächen				
	mm 10	mm 10	mm 10	mm 10
 Stonalizzazione accentuata Shade variation accentuated Variations d'ombre forte Farbtonvarianten Akzentuiert				 Naturale Matt Naturelle Matt R10  Grip R11

Rettificata in un unico calibro Rectified version in a single caliber Rectifiés en un unique calibre Boden Sie in einem einzigen Kaliber

Caratteristiche tecniche e imballi a pagina: Technical features and packing on page: Caractéristiques techniques et emballages à la page: Technische Eigenschaften und Verpackungen auf Seite: **501**

PEZZI SPECIALI TRIMS ACCESSOIRES FORMSTÜCKE

Battiscopa Bullnose
Plinthe à bord arrondi
Stehsokkel
cm 9x90 - 3¹/₂"x35³/₈"
cm 9x60 - 3¹/₂"x23⁵/₈"



Gradino Step tread
Nez de marche Stufenplatte
cm 30x90 - 11³/₄"x35³/₈"
cm 30x60 - 11³/₄"x23⁵/₈"

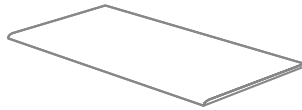

Gradone (assemblato)
cm 90x33 - 35³/₈"x13"

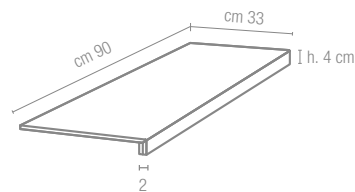

Angolare (assemblato)
cm 90x33 - 35³/₈"x13"

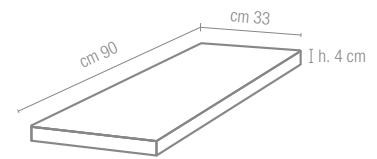

soho cm 90x90 - 35³/₈"x35³/₈"



DECORI DECORS DÉCORS DEKORE

manhattan

GRANITOKER

mosaico 6x6 harlem



cm 30x30 - 11³/₄"x11³/₄"
tessera **cm 6x6** - 2³/₈"x2³/₈"
su rete on net sur trame auf Netz

mosaico 6x6 queens



cm 30x30 - 11³/₄"x11³/₄"
tessera **cm 6x6** - 2³/₈"x2³/₈"
su rete on net sur trame auf Netz

mosaico 6x6 soho



cm 30x30 - 11³/₄"x11³/₄"
tessera **cm 6x6** - 2³/₈"x2³/₈"
su rete on net sur trame auf Netz

mosaico 6x6 tribeca



cm 30x30 - 11³/₄"x11³/₄"
tessera **cm 6x6** - 2³/₈"x2³/₈"
su rete on net sur trame auf Netz



tribeca **cm 90x90** - 35³/₈"x35³/₈"

black

r-evolution

GRANITOKER



black cm 60x120 - 23⁵/₈"x47¹/₄", **grey** cm 60x120 - 23⁵/₈"x47¹/₄"

COLORI COLOURS COULEURS FARBEN

r-evolution black



r-evolution dark grey



r-evolution blue

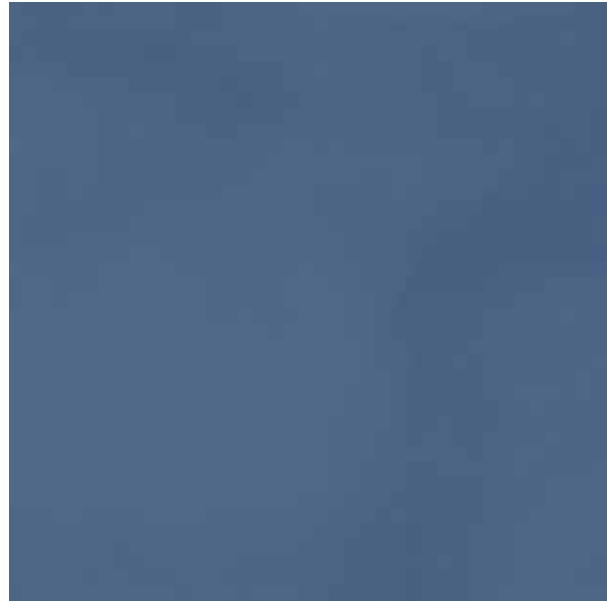

r-evolution terra



r-evolution tortora



r-evolution sand

r-evolution

GRANITOKER

r-evolution azure



r-evolution green



r-evolution light pink



r-evolution grey







r-evolution white



r-evolution total white

FORMATI SIZES FORMATS FORMATE

Formati Sizes Formats Formate	 cm 30x60 11 ³ / ₄ "x23 ⁵ / ₈ "	 cm 60x60 23 ⁵ / ₈ "x23 ⁵ / ₈ "	 cm 60x120 23 ⁵ / ₈ " x47 ¹ / ₄ "
Superfici Surfaces Surfaces Oberflächen	●	●	●
	mm 10	mm 10	mm 10



Stonizzazione accentuata
Shade variation accentuated
Variations d'ombre forte
Farbtonvarianten Akzentuiert

● Naturale Matt Naturelle Matt

Rettificate in un unico calibro Rectified version in a single caliber Rectifiés en un unique calibre Boden Sie in einem einzigen Kaliber

Consigliata per residenziale e commerciale leggero Suitable for residential or light commercial Conseillé pour résidentielle et commerciale à circulation légère Geeignet für wohn oder leichte kommerzielle

Caratteristiche tecniche e imballi a pagina: Technical features and packing on page: Caractéristiques techniques et emballages à la page: Technische Eigenschaften und Verpackungen auf Seite: **501**



r-evolution grey cm 60x120 - 23⁵/₈"x47¹/₄"

PEZZI SPECIALI TRIMS ACCESSOIRES FORMSTÜCKE

Battiscopa Bullnose
Plinthe à bord arrondi
Stehsockel
cm 9x60 - 3¹/₂"x23⁵/₈"



Gradino Step tread
Nez de marche **Stufenplatte**
cm 30x60 - 11³/₄"x23⁵/₈"

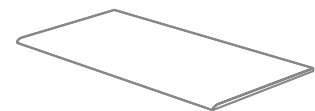

Gradone (assemblato)
cm 60x33 - 35³/₈"x13"

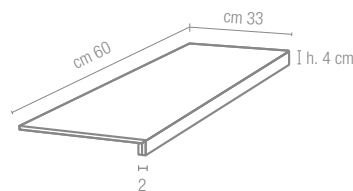

Angolare (assemblato)
cm 60x33 - 35³/₈"x13"

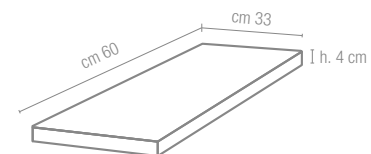

r-evolution

GRANITOKER

DECORI DECORS DÉCORS DEKORE

stripes**

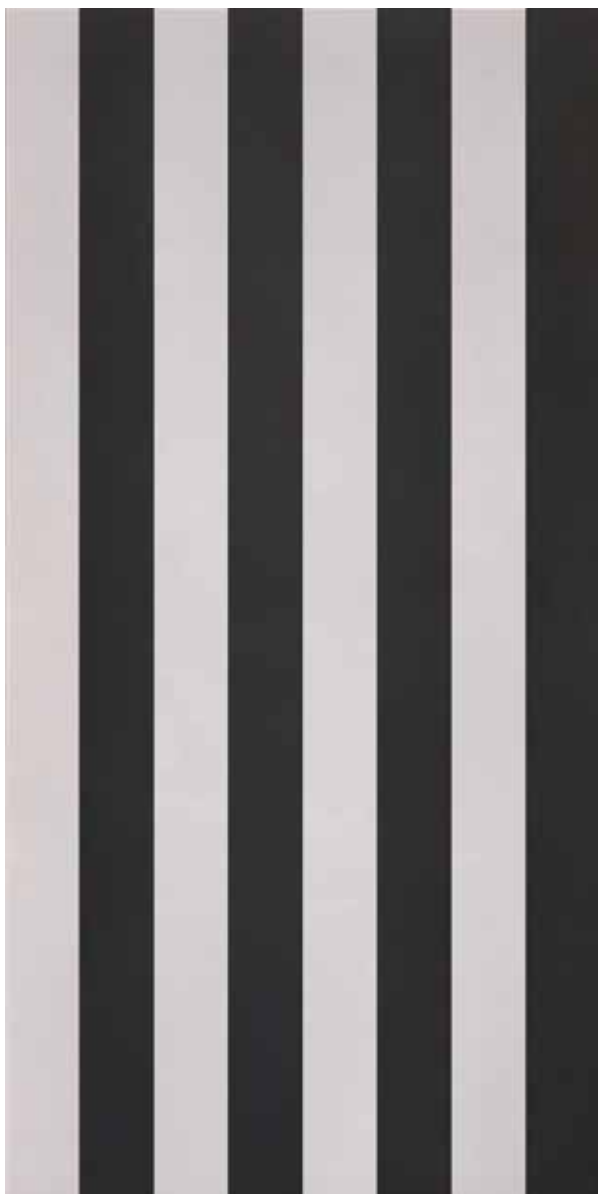

cm 60x120 - 23⁵/₈" x 47¹/₄"

row A*



cm 30x60 - 11³/₄" x 23⁵/₈"

row B*



cm 30x60 - 11³/₄" x 23⁵/₈"

row C*



cm 30x60 - 11³/₄" x 23⁵/₈"

row D*



cm 30x60 - 11³/₄" x 23⁵/₈"

* Disponibile in tutti i colori della serie Available in all the colours of the series Disponible dans toutes les couleurs de la série Verfügbar in allen Farben
Bacchetta nei colori: Stick in the colours: Baguette dans les couleurs de la série: Zauberstabfarben:
Black, Blue, Dark Grey, Green, Light Pink, Terra

** Disponibile nei colori: Available in the colours: Disponible dans les couleurs : Verfügbar in den folgenden Farben:
A (Total White/Black), B (White/Grey), C (San/Tortora), D (Total White/Blu)

beton

GRANITOKER



beton ivory cm 75,5x151 - 29³/₄"x59¹/₂"

COLORI COLOURS COULEURS FARBEN

beton dark



beton pearl

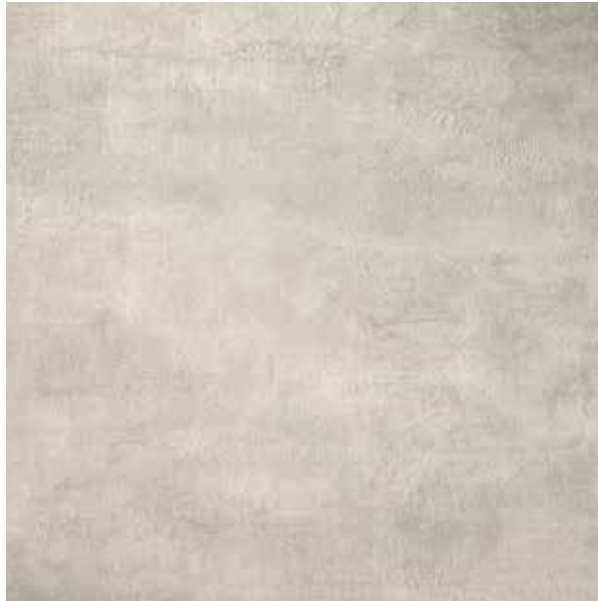

beton mud



beton sand



beton ivory





beton

GRANITOKER



beton dark cm 75,5x75,5 - 29³/₄"x29³/₄"

FORMATI SIZES FORMATS FORMATE

Formati Sizes Formats Formate			
	cm 37,5x75,5 14 ³ / ₄ "x29 ³ / ₄ "	cm 75,5x75,5 29 ³ / ₄ "x29 ³ / ₄ "	cm 75,5x151 29 ³ / ₄ "x59 ¹ / ₂ "
Superfici Surfaces Surfaces Oberflächen	●	●	●
	mm 10 mm 9	mm 10	mm 10



Stonizzazione media
Shade variation medium
Variations d'ombre moyenne
Farbtonvarianten Mittel

● Naturale Matt Naturelle Matt **R10**

Rettificata in un unico calibro Rectified version in a single caliber Rectifiés en un unique calibre Boden Sie in einem einzigen Kaliber

Caratteristiche tecniche e imballi a pagina: Technical features and packing on page: Caractéristiques techniques et emballages à la page: Technische Eigenschaften und Verpackungen auf Seite: **501**



beton sand cm 75,5x151 - 29³/₄"x59¹/₂"

PEZZI SPECIALI TRIMS ACCESSOIRES FORMSTÜCKE

Battiscopa Bullnose
Plinthe à bord arrondi
Stehsockel
cm 9x75,5 - 3¹/₂"x29³/₄"



Gradino Step tread
Nez de marche Stufenplatte
cm 37,5x75,5 - 14³/₄"x29³/₄"

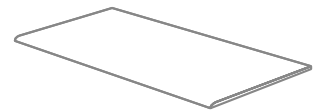

Gradone (assemblato)
cm 75,5x33 - 29³/₄"x13"

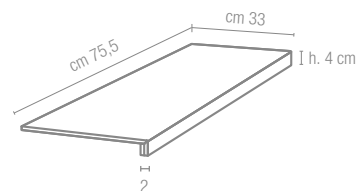

Angolare (assemblato)
cm 75,5x33 - 29³/₄"x13"

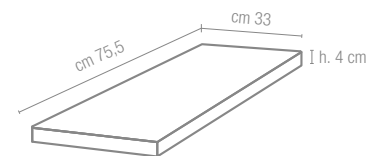

beton

GRANITOKER



beton pearl cm 75,5x151 - 29³/₄"x59¹/₂"

DECORI DECORS DÉCORS DEKORE

inserto beton A

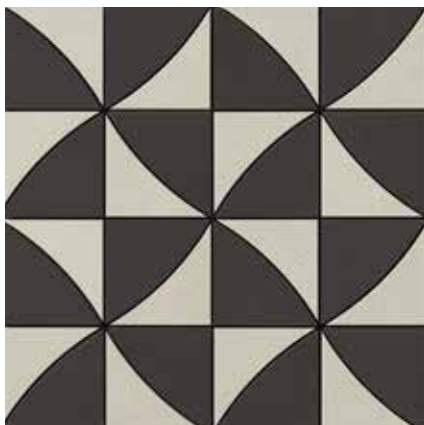

cm 37,5x37,5 - 14³/₄"x14³/₄"
1. pearl+dark - 2. mud+ivory

inserto beton B



cm 37,5x37,5 - 14³/₄"x14³/₄"
1. pearl+dark - 2. mud+ivory

inserto beton C

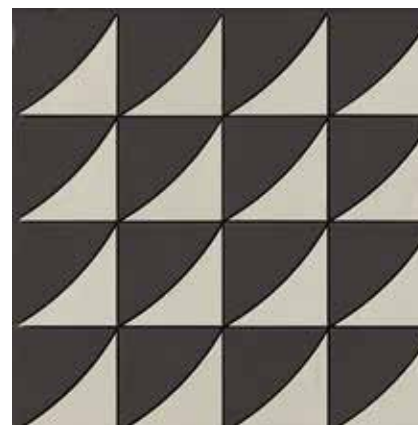

cm 37,5x37,5 - 14³/₄"x14³/₄"
1. pearl+dark - 2. mud+ivory

inserto beton D



cm 37,5x37,5 - 14³/₄"x14³/₄"
1. pearl+dark - 2. mud+ivory

inserto beton E



cm 37,5x37,5 - 14³/₄"x14³/₄"
1. pearl+dark - 2. mud+ivory

beton

GRANITOKER

inserto beton E1, inserto beton C cm 37,5x37,5 - 14³/₄"x14³/₄"

DECORI DECORS DÉCORS DEKORE

quadrotta beton pearl



cm 25,1x25,1 - 9⁷/₈"x9⁷/₈"



cm 25,1x25,1 - 9⁷/₈"x9⁷/₈"
pearl

mosaico tessuto



cm 25,1x25,1 - 9⁷/₈"x9⁷/₈"
1. pearl+dark - 2. mud+ivory

mosaico 6x6*



cm 30x30 - 11³/₄"x11³/₄"
tessera cm 6x6 - 2³/₈"x2³/₈"
su rete on net sur trame auf Netz

* Disponibile in tutti i colori della serie Available in all the colours of the series Disponible dans tous les couleurs de la série Verfügbar in allen Farben

beton

GRANITOKER

mosaico tessuto pearl+dark cm 25,1x25,1 - 9⁷/₈"x9⁷/₈", beton dark cm 75,5x151 - 29³/₄"x59¹/₂"

DECORI DECORS DÉCORS DEKORE

affresco

**cm 75,5x151 - 29³/₄"x59¹/₂"***decorato a mano hand decorated décoré à la main Handbemalt*

beton

GRANITOKER



affresco beton sand cm 75,5x151 - 29³/₄"x59¹/₂", **beton sand** cm 75,5x151 - 29³/₄"x59¹/₂"
beton pearl cm 75,5x151 - 29³/₄"x59¹/₂"

cemento rasato antracite

cemento

GRANITOKER



rasato antracite cm 60x120 - 23⁵/₈"x47¹/₄"

COLORI COLOURS COULEURS FARBEN

cassero antracite



cassero grigio



cassero beige



rasato antracite



rasato grigio



rasato beige

cemento

GRANITOKER

cassero bianco













rasato bianco



rasato grigio cm 60x60 - 23⁵/₈"x23⁵/₈",
cassero grigio cm 60x120 - 23⁵/₈"x47¹/₄"

FORMATI SIZES FORMATS FORMATE

					
Formati Sizes Formats Formate	cm 30x60 11 ³ / ₄ "x23 ⁵ / ₈ "	cm 60x60 23 ⁵ / ₈ "x23 ⁵ / ₈ "	cm 37,5x75,5 14 ³ / ₄ "x29 ³ / ₄ "	cm 75,5x75,5 29 ³ / ₄ "x29 ³ / ₄ "	cm 60x120 23 ⁵ / ₈ "x47 ¹ / ₄ "
Superfici Surfaces Surfaces Oberflächen					
	mm 10 mm 9 mm 9*	mm 10	mm 10 mm 9	mm 10	mm 10



Stonalizzazione media
Shade variation medium
Variations d'ombre moyenne
Farbtonvarianten Mittel

 Cassero **R10**
 ** Cassero
 Rasato **R9**

* Non rettificato Unrectified Non rectifié Nicht kalibriert

** Superficie non strutturata Untextured surface Surface non structurée Nicht-strukturierte Oberfläche

Rettificate in un unico calibro Rectified version in a single caliber Rectifiés en un unique calibre Boden Sie in einem einzigen Kaliber

Caratteristiche tecniche e imballi a pagina: Technical features and packing on page: Caractéristiques techniques et emballages à la page: Technische Eigenschaften und Verpackungen auf Seite: **501**



rasato grigio, cassero grigio cm 60x120 - 23⁵/₈"x47¹/₄"
listelli cemento grigio cm 30x30 - 11³/₄"x11³/₄"

cemento

GRANITOKER



cm 60x120
23⁵/₈"x47¹/₄"



mm 6,5



cm 120x120
47¹/₄"x47¹/₄"



mm 6,5
mm 10

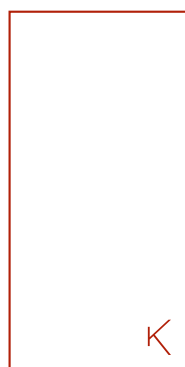

cm 120x240
47¹/₄"x94¹/₂"



mm 6,5

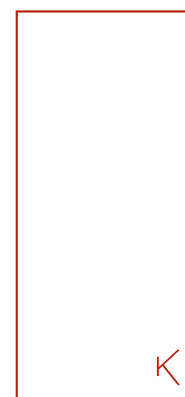

cm 120x260
47¹/₄"x102³/₈"



mm 6,5

- K Lastre Kontinua
- K Kontinua Slabs
- Dalles Kontinua
- K Kontinua Platten

PEZZI SPECIALI TRIMS ACCESSOIRES FORMSTÜCKE

Battiscopa Bullnose
Plinthe à bord arrondi
Stehsockel
cm 9x60 - 3¹/₂"x23⁵/₈"
cm 9x75,5 - 3¹/₂"x29³/₄"



Gradino Step tread
Nez de marche Stufenplatte
cm 30x60 - 11³/₄"x23⁵/₈"

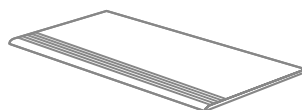

Gradone (assemblato)
cm 60x33 - 23⁵/₈"x13"
cm 120x33 - 47¹/₄"x13"

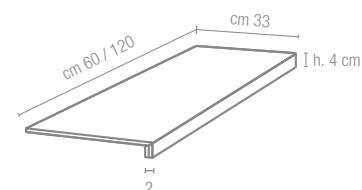

Angolare (assemblato)
cm 60x33 - 23⁵/₈"x13"
cm 120x33 - 47¹/₄"x13"

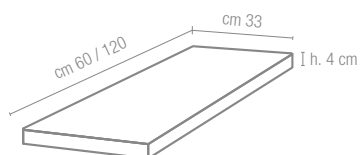

rasato beige cm 60x120 - 23⁵/₈"x47¹/₄"
composizione A beige cm 30x60 - 11³/₄"x 23⁵/₈"

DECORI DECORS DÉCORS DEKORE

listelli cemento*

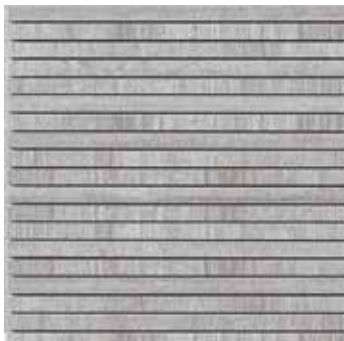

cm 30x30 - 1 1³/₄"x1 1³/₄"

listello **cm 1,4x30** - 1/2"x1 1³/₄"
su rete on net sur trame auf Netz

Solo superficie cassero Cassero surface only
 Seulement surface cassero
 Nur in der "Cassero" Oberfläche

mosaico cemento*

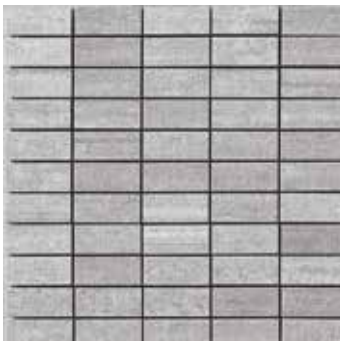

cm 30x30 - 1 1³/₄"x1 1³/₄"

tessera **cm 5,7x2,5** - 2 1/4"x1"
su rete on net sur trame auf Netz

Solo superficie cassero Cassero surface only
 Seulement surface cassero
 Nur in der "Cassero" Oberfläche

mosaico 6x6*



cm 30x30 - 1 1³/₄"x1 1³/₄"

tessera **cm 6x6** - 2 3/8"x2 3/8"

Superficie cassero e rasato Cassero and rasato surface
 Surface cassero et rasato
 Nur in der "cassero" und "rasato" Oberfläche.

rug cemento*

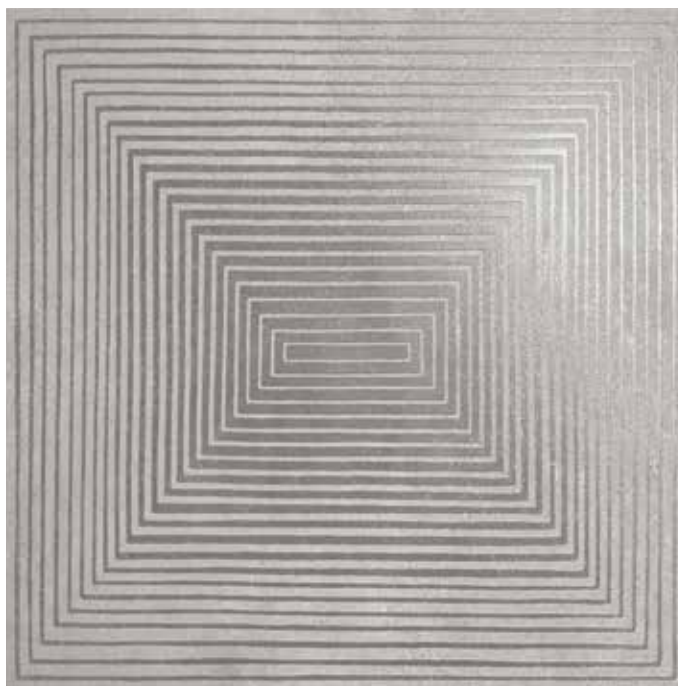

cm 60x60 - 23 5/8"x23 5/8"

Solo superficie cassero Cassero surface only
 Seulement surface cassero Nur in der "Cassero" Oberfläche

* Disponibile in tutti i colori della serie Available in all the colours of the series Disponible dans tous les couleurs e la série Verfügbar in allen Farben

cemento

GRANITOKER

quadrotta cemento rasato grigio



cm 25,1x25,1 - 97/8"x97/8"



cm 25,1x25,1 - 97/8"x97/8"
rasato grigio

mosaico tessuto

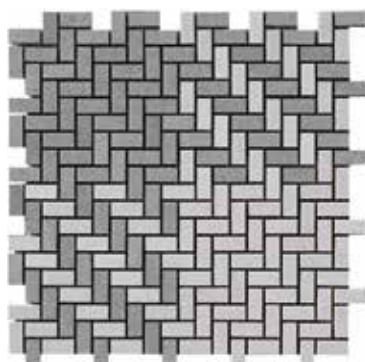

cm 25,1x25,1 - 97/8"x97/8"

1. Rasato Antracite + Rasato Grigio
2. Rasato Grigio + Rasato Bianco

Solo superficie rasato Rasato surface only
Seulement surface rasato Nur in der "Rasato" Oberfläche.

composizione A*



cm 30x60 - 113/4"x235/8"
su rete on net sur trame auf Netz

Solo superficie cassero Cassero surface only
Seulement surface cassero Nur in der "Cassero" Oberfläche

DECORI DECORS DÉCORS DEKORE

blue falls



cm 120x240 - 47¹/₄"x 94¹/₂"

Kontinua  mm 6,5

cemento

GRANITOKER

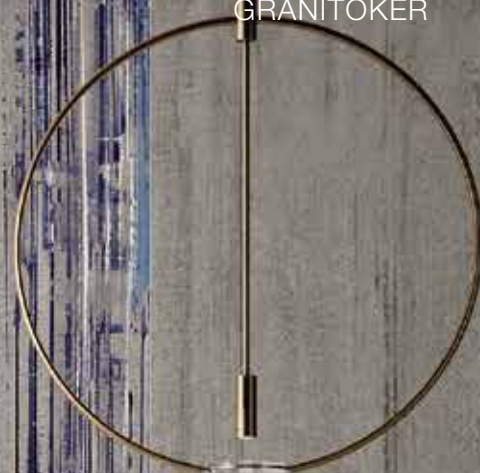

cassero grigio cm 120x240 - 47¹/₄"x94¹/₂"
blue falls cm 120x240 - 47¹/₄"x94¹/₂"

resina

GRANITOKER



resina havana cm 90x180 - 35³/₈"x70⁷/₈", **resina white** cm 90x180 - 35³/₈"x70⁷/₈"

COLORI COLOURS COULEURS FARBEN

resina black



resina havana



resina tobacco



resina grey



resina white

resina

GRANITOKER



resina black cm 90x180 - 35³/₈"x70⁷/₈", cm 45x90 - 17³/₄"x35³/₈" , cm 90x90 - 35³/₈" 35³/₈"

FORMATI SIZES FORMATS FORMATE

Formati Sizes Formats Formate	cm 30x60 11 ³ / ₄ "x23 ⁵ / ₈ "	cm 60x60 23 ⁵ / ₈ "x23 ⁵ / ₈ "	cm 45x90 17 ³ / ₄ "x35 ³ / ₈ "	cm 90x90 35 ³ / ₈ "x35 ³ / ₈ "	cm 60x120 23 ⁵ / ₈ "x47 ¹ / ₄ "	cm 90x180 35 ³ / ₈ "x70 ⁷ / ₈ "
Superfici Surfaces Surfaces Oberflächen	●	●	●	●	●	●
	mm 10	mm 10	mm 10	mm 10	mm 10	mm 10



Stonizzazione leggera
Shade variation subtle
Variations d'ombre légère
Farbtonvarianten Leicht

● Naturale Matt Naturelle Matt **R9**

Rettificate in un unico calibro Rectified version in a single caliber Rectifiés en un unique calibre Boden Sie in einem einzigen Kaliber

Caratteristiche tecniche e imballi a pagina: Technical features and packing on page: Caractéristiques techniques et emballages à la page: Technische Eigenschaften und Verpackungen auf Seite: **501**

PEZZI SPECIALI TRIMS ACCESSOIRES FORMSTÜCKE

Battiscopa Bullnose
Plinthe à bord arrondi
Stehsockel
cm 9x90 - 3¹/₂"x35³/₈"
cm 9x60 - 3¹/₂"x23⁵/₈"



Gradino Step tread
Nez de marche **Stufenplatte**
cm 30x90 - 11³/₄"x35³/₈"
cm 30x60 - 11³/₄"x23⁵/₈"

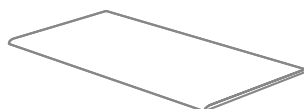

Gradone (assemblato)
cm 120x33 - 47¹/₄"x13"
cm 90x33 - 35³/₈"x13"

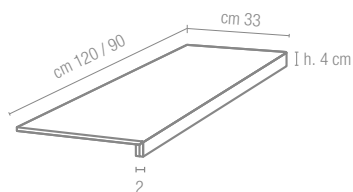

Angolare (assemblato)
cm 120x33 - 47¹/₄"x13"
cm 90x33 - 35³/₈"x13"

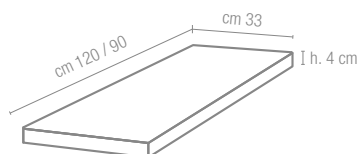

DECORI DECORS DÉCORS DEKORE

resina

GRANITOKER

mosaico 6x6*



cm 30x30 - 11³/₄"x11³/₄"
 tessera **cm 6x6** - 2³/₈"x2³/₈"
 su rete on net sur trame auf Netz

composizione D*



cm 28,5x57,6 - 11¹/₄"x22⁵/₈"
 mattoncino **cm 7x28** - 2³/₄"x11¹/₄"
 su rete on net sur trame auf Netz

coprispigolo*



cm 45x1,2 - 17³/₄"x³/₈"

mosaico penta



cm 31,6x63,2 - 12¹/₂"x23⁷/₈"
 black + havana + tabacco

fascia resina*



cm 22,5x90 - 8⁷/₈"x35³/₈"

* Disponibile in tutti i colori della serie Available in all the colours of the series Disponible dans tous les couleurs de la série Verfügbar in allen Farben.

DECORI DECORS DÉCORS DEKORE

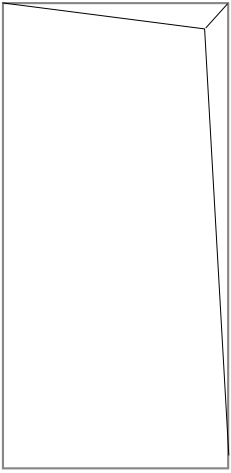

cm 45x90 - 17³/₄"x35³/₈"

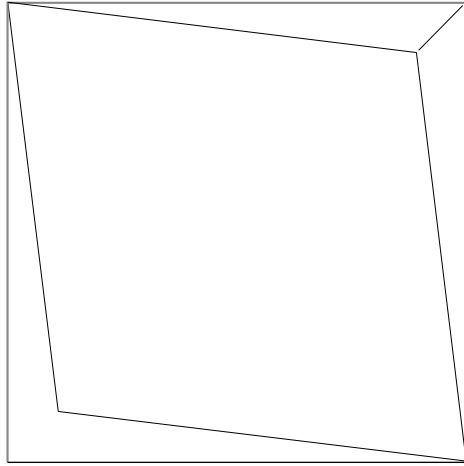

cm 90x90 - 35³/₈"x35³/₈"

shades black



shades grey

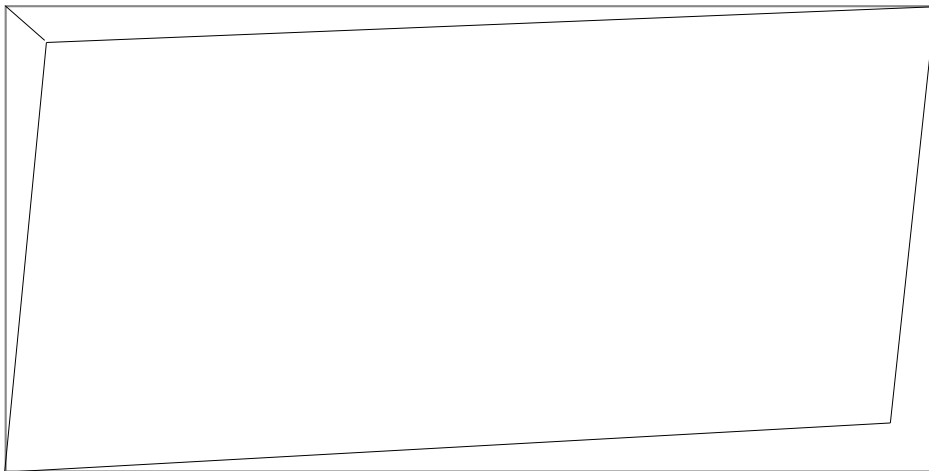

cm 90x180 - 35³/₈"x70⁷/₈"

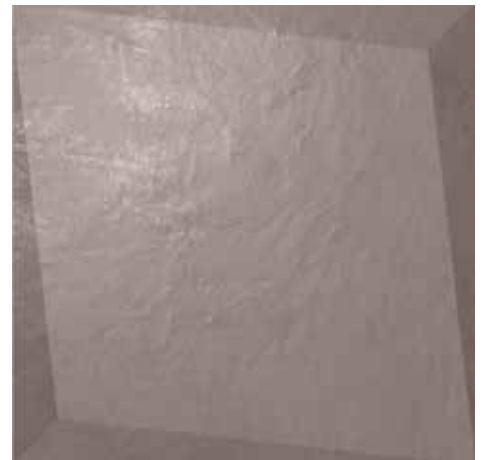

shades tobacco



resina

GRANITOKER



resina white, resina grey cm 90x90 - 35³/₈"x70⁷/₈"

spazio

PIETRE NATIVE



spazio antracite cm 60x60 - 23⁵/₈"x23⁵/₈"

COLORI COLOURS COULEURS FARBEN

spazio antracite



spazio bronzo



spazio tabacco

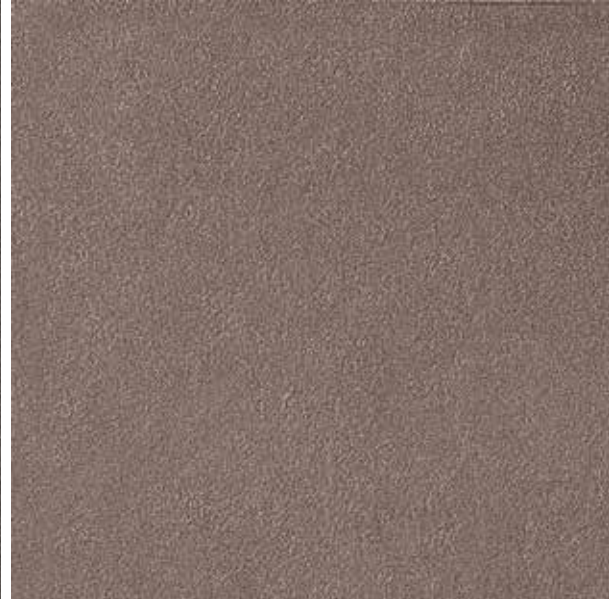

spazio perla



spazio argento



spazio beige

spazio

PIETRE NATIVE

spazio tortora

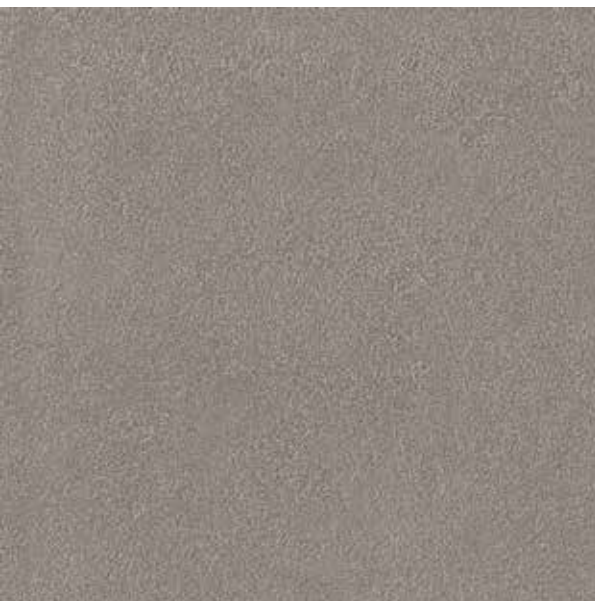

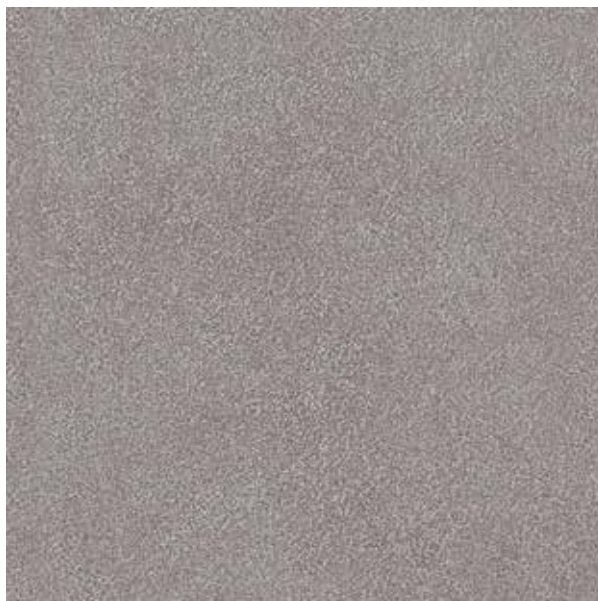

spazio grigio



spazio bianco

FORMATI SIZES FORMATS FORMATE

Formati Sizes Formats Formate	cm 30x30 11 ³ / ₄ "x11 ³ / ₄ "	cm 45x45 17 ³ / ₄ "x17 ³ / ₄ "	cm 30x60 11 ³ / ₄ "x23 ⁵ / ₈ "	cm 60x60 23 ⁵ / ₈ "x23 ⁵ / ₈ "	cm 37,5x75,5 14 ³ / ₄ "x29 ³ / ₄ "	cm 75,5x75,5 29 ³ / ₄ "x29 ³ / ₄ "
Superfici Surfaces Surfaces Oberflächen	●	●	●	●	●	●
	mm 9	mm 9	mm 10	mm 10	mm 10	mm 10
			mm 9	mm 14*	mm 9	



Stonizzazione leggera
Shade variation subtle
Variations d'ombre légère
Farbtonvarianten Leicht

● Naturale Matt Naturelle Matt **R10**

Rettificate in un unico calibro Rectified version in a single caliber Rectifiés en un unique calibre Boden Sie in einem einzigen Kaliber

* Solo nei colori: Only in the colours: Seulement dans les couleurs : Nur in die Farben: **Antracite, Argento, Bianco, Grigio**

Caratteristiche tecniche e imballi a pagina: Technical features and packing on page: Caractéristiques techniques et emballages à la page: Technische Eigenschaften und Verpackungen auf Seite: **498**

PEZZI SPECIALI TRIMS ACCESSOIRES FORMSTÜCKE

Battiscopa Bullnose Plinthe à bord arrondi Stehsockel

cm 9x30 - 3¹/₂"x11³/₄"
cm 9x45 - 3¹/₂"x17³/₄"
cm 9x60 - 3¹/₂"x23⁵/₈"
cm 9x75,5 - 3¹/₂"x29³/₄"



Gradino Step tread Nez de marche Stufenplatte

cm 30x30 - 11³/₄"x11³/₄"
cm 45x45 - 17³/₄"x17³/₄"
cm 30x60 - 11³/₄"x23⁵/₈"

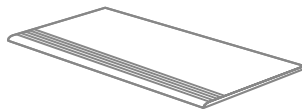

Listello Listel Listel Zeilerleiste

cm 9x30 - 3¹/₂"x11³/₄"



Tozzetto Insert Cabocho Einleger

cm 9x9 - 3¹/₂"x3¹/₂"

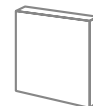

Gradone (assemblato) cm 60x33 - 23⁵/₈"x13"

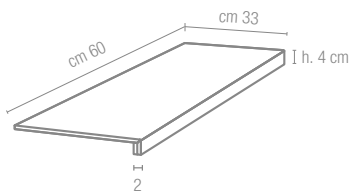

Angolare (assemblato) cm 60x33 - 23⁵/₈"x13"

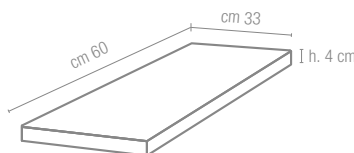

Terminale Pezzo incollato Glued piece Pièce collée Geklebter Stück

cm 15x30x5 - 5⁷/₈"x11³/₄"x2"

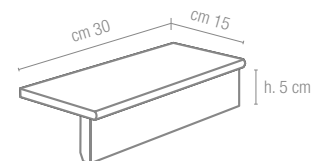

DECORI DECORS DÉCORS DEKORE

spazio

PIETRE NATIVE

mix listelli spazio A



cm 30x30 - 11³/₄"x11³/₄"
listello **cm 1,4x30 - 1/2"x11³/₄"**
su rete on net sur trame auf Netz
bianco, argento, grigio

mix listelli spazio B

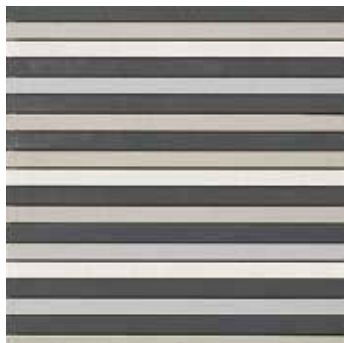

cm 30x30 - 11³/₄"x11³/₄"
listello **cm 1,4x30 - 1/2"x11³/₄"**
su rete on net sur trame auf Netz
antracite, grigio, bianco, argento

mix listelli spazio C

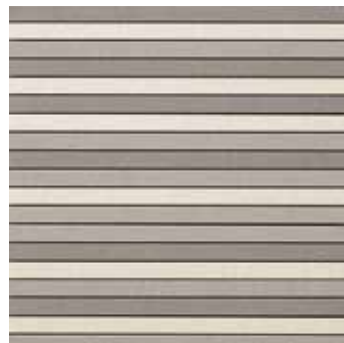

cm 30x30 - 11³/₄"x11³/₄"
listello **cm 1,4x30 - 1/2"x11³/₄"**
su rete on net sur trame auf Netz
beige, tortora, perla

mix listelli spazio D



cm 30x30 - 11³/₄"x11³/₄"
listello **cm 1,4x30 - 1/2"x11³/₄"**
su rete on net sur trame auf Netz
bronzo, antracite, tabacco

mosaico 6x6*



cm 30x30 - 11³/₄"x11³/₄"
tessera **cm 6x6 - 2³/₈"x2³/₈"**
su rete on net sur trame auf Netz

* Disponibile in tutti i colori della serie
Available in all the colours of the series
Disponibile dans tous les couleurs de la série
Verfügbar in allen farben



mix listelli spazio C

cm 30x30 - 11³/₄"x11³/₄"
spazio beige **cm 30x30 - 11³/₄"x11³/₄"** ,
cm 60x60 - 23⁵/₈"x23⁵/₈"

econcrete

GRESPLUS



eco grigio cm 60x60 - 23⁵/₈"x23⁵/₈"

COLORI COLOURS COULEURS FARBEN

eco antracite



eco beige



eco bianco



eco cenere



eco grigio

FORMATI SIZES FORMATS FORMATE

econcrete

GRESPLUS

Formati Sizes
Formats Formate



cm 45x45
17³/₄"x 17³/₄"



cm 30x60
11³/₄"x23⁵/₈"



cm 60x60
23⁵/₈"x23⁵/₈"

Superfici Surfaces
Surfaces Oberflächen



mm 8



mm 8



mm 9



Stonizzazione media
Shade variation medium
Variations d'ombre moyenne
Farbtonvarianten Mittel

- Naturale Matt Naturelle Matt **R10 A+B**
- * Naturale Matt Naturelle Matt **R9**
- Grip **R11 A+B**

Rettificate in un unico calibro Rectified version in a single caliber Rectifiés en un unique calibre Boden Sie in einem einzigen Kaliber

Caratteristiche tecniche e imballi a pagina: Technical features and packing on page: Caractéristiques techniques et emballages à la page: Technische Eigenschaften und Verpackungen auf Seite: **504**

PEZZI SPECIALI TRIMS ACCESSOIRES FORMSTÜCKE

Battiscopa Bullnose
Plinthe à bord arrondi
Stehsockel
cm 9x60 - 3¹/₂"x23⁵/₈"



Gradino Step tread
Nez de marche
Stufenplatte
cm 30x60 - 11³/₄"x23⁵/₈"

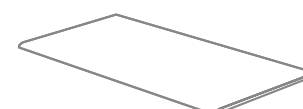

DECORI DECORS DÉCORS DEKORE

mosaico 6x6*



cm 30x30 - 11³/₄"x11³/₄"
tessera **cm 6x6** - 2³/₈"x2³/₈"
su rete on net sur trame auf Netz

- * Disponibile in tutti i colori della serie
Available in all the colours of the series
Disponibile dans tous les couleurs de la série
Verfügbar in allen Farben

opus

GRANITOKER



opus grigio cm 20x20 - 7⁷/₈"x7⁷/₈", **cementina grigia mix** cm 20x20 - 7⁷/₈"x7⁷/₈"

COLORI COLOURS COULEURS FARBEN

opus beige



opus grigio



FORMATI SIZES FORMATS FORMATE

opus

GRANITOKER

Formati Sizes
Formats Formate



cm 20x20
7⁷/₈"x7⁷/₈"

Superfici Surfaces
Surfaces Oberflächen



mm 9



Stonizzazione accentuata
Shade variation accentuated
Variations d'ombre forte
Farbtonvarianten Akzentuiert

● Naturale Matt Naturelle Matt **R9**

Caratteristiche tecniche e imballi a pagina: Technical features and packing on page: Caractéristiques techniques et emballages à la page: Technische Eigenschaften und Verpackungen auf Seite: **501**

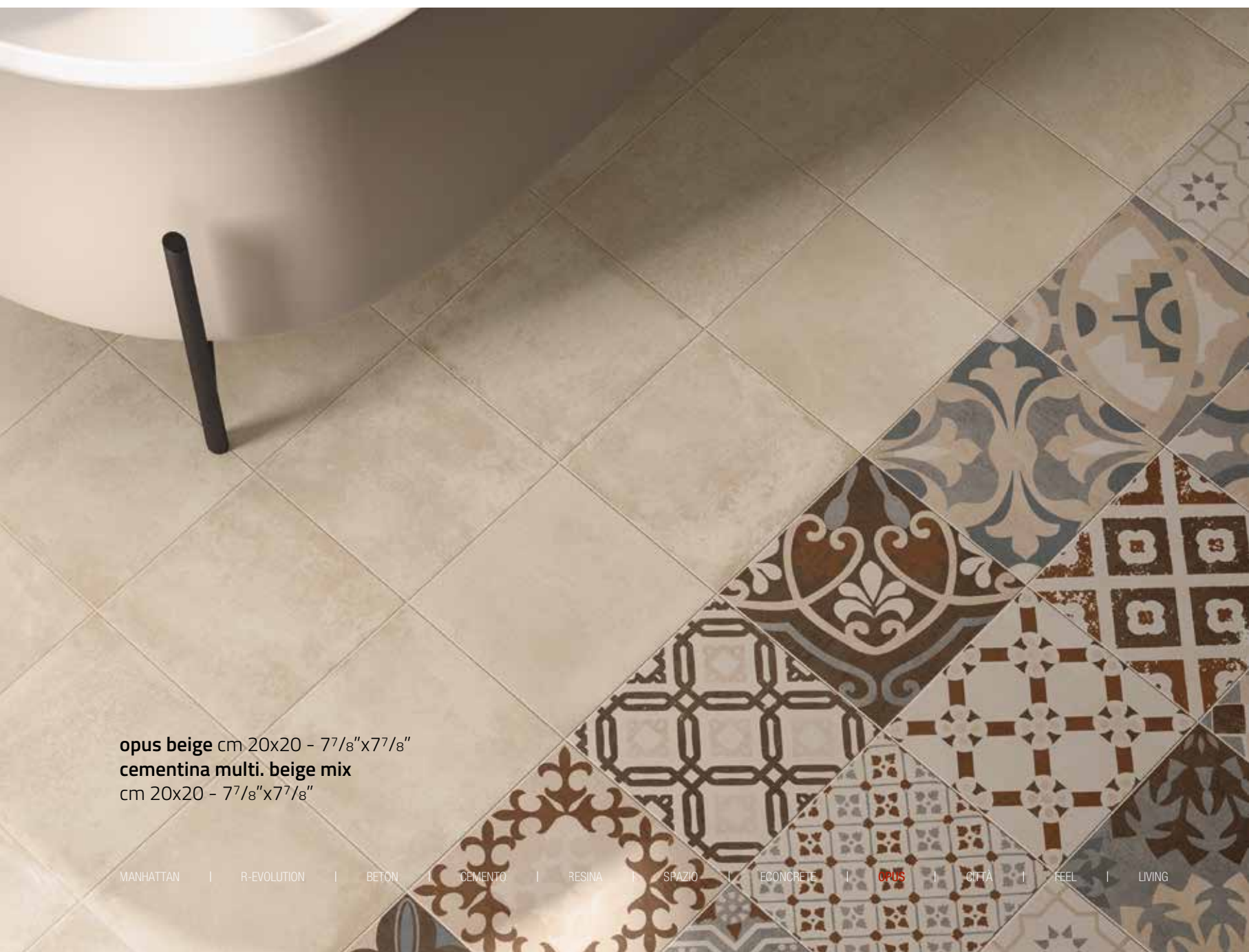

opus beige cm 20x20 - 7⁷/₈"x7⁷/₈"
cementina multi. beige mix
cm 20x20 - 7⁷/₈"x7⁷/₈"

DECORI DECORS DÉCORS DEKORE

cementina
multi. beige A*

cm 20x20 - 77/8"x77/8"

cementina
multi. beige B*

cm 20x20 - 77/8"x77/8"

cementina
multi. beige C*

cm 20x20 - 77/8"x77/8"

cementina
multi. beige D*

cm 20x20 - 77/8"x77/8"

cementina multi. beige mix**

cm 20x20 - 77/8"x77/8"



* Ordinabili singolarmente (minimo 1 scatola) Option to choose specific designs (min. one box) Possibilité de commande séparée (1 boîte minimum) Einzel bestellbar (mindestens 1 Karton)

** Non ordinabili singolarmente (ogni scatola contiene un mix di soggetti diversi) Specific designs not available (each box contains a mix of different designs)

Pas de possibilité de commande séparée (chaque boîte contient un mélange de décors différents) Nicht einzeln bestellbar (jeder Karton enthält eine Mischung unterschiedlicher Elemente)

opus

GRANITOKER

cementina multi. beige mix cm 20x20 - 7 7/8" x 7 7/8"

DECORI DECORS DÉCORS DEKORE

cementina
multi. grigia A*

cm 20x20 - 77/8"x77/8"

cementina
multi. grigia B*

cm 20x20 - 77/8"x77/8"

cementina
multi. grigia C*

cm 20x20 - 77/8"x77/8"

cementina
multi. grigia D*

cm 20x20 - 77/8"x77/8"

cementina multi. grigia mix**

cm 20x20 - 77/8"x77/8"



* Ordinabili singolarmente (minimo 1 scatola) Option to choose specific designs (min. one box) Possibilité de commande séparée (1 boîte minimum) Einzel bestellbar (mindestens 1 Karton)

** Non ordinabili singolarmente (ogni scatola contiene un mix di soggetti diversi) Specific designs not available (each box contains a mix of different designs)

Pas de possibilité de commande séparée (chaque boîte contient un mélange de décors différents) Nicht einzeln bestellbar (jeder Karton enthält eine Mischung unterschiedlicher Elemente)

opus

GRANITOKER



opus grigio cm 20x20 - 7⁷/₈"x7⁷/₈", cementina multi. grigia mix cm 20x20 - 7⁷/₈"x7⁷/₈"

DECORI DECORS DÉCORS DEKORE

cementina grigia mix*

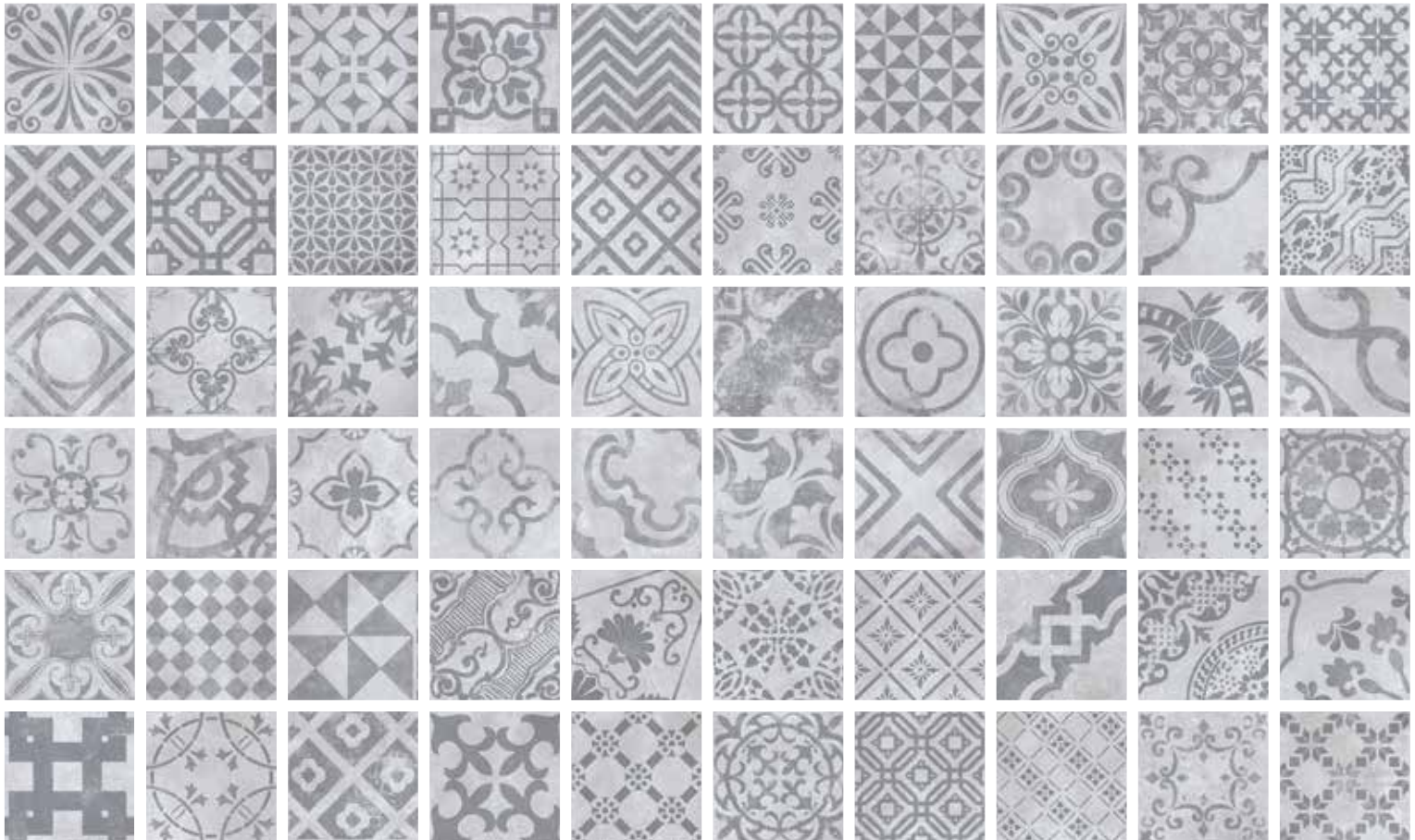
cm 20x20 - 7⁷/₈"x7⁷/₈"

* Non ordinabili singolarmente (ogni scatola contiene un mix di soggetti diversi) Specific designs not available (each box contains a mix of different designs)

Pas de possibilité de commande séparée (chaque boîte contient un mélange de décors différents) Nicht einzeln bestellbar (jeder Karton enthält eine Mischung unterschiedlicher Elemente)

opus

GRANITOKER



opus grigio cm 20x20 - 77/8"x77/8", cementina grigia mix cm 20x20 - 77/8"x77/8"

città

GRESPLUS



berlino, stoccolma. mosca cm 30x60 - 11³/₄"x23⁵/₈"

COLORI COLOURS COULEURS FARBEN

rotterdam



berlino



stoccolma



londra



atene



praga

FORMATI SIZES FORMATS FORMATE

città
GRESPLUS

mosca



lisbona

Formati Sizes Formats Formate	cm 45x45 17 ³ / ₄ "x 17 ³ / ₄ "	cm 30x60 11 ³ / ₄ "x23 ⁵ / ₈ "	cm 60x60 23 ⁵ / ₈ "x23 ⁵ / ₈ "
Superfici Surfaces Surfaces Oberflächen	●	●	●
	mm 8*	mm 8 mm 9*	mm 9
Stonalizzazione media Shade variation medium Variations d'ombre moyenne Farbtonvarianten Mittel			● Naturale Matt Naturelle Matt

* Non rettificato Unrectified Non rectifié Nicht kalibriert

Rettificate in un unico calibro Rectified version in a single caliber
Rectifiés en un unique calibre Boden Sie in einem einzigen Kaliber

Caratteristiche tecniche e imballi a pagina: Technical features and packing on page:
Caractéristiques techniques et emballages à la page Technische: Eigenschaften und Verpackungen auf Seite: **504**

PEZZI SPECIALI TRIMS ACCESSOIRES FORMSTÜCKE

Battiscopa Bullnose
Plinthe à bord arrondi
Stehsockel
cm 9x45 - 3¹/₂"x23⁵/₈"
cm 9x60 - 3¹/₂"x17³/₄"



Gradino Step tread
Nez de marche
Stufenplatte
cm 30x60 - 11³/₄"x23⁵/₈"

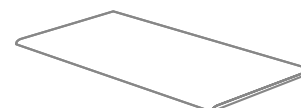



feel grey cm 41,5x41,5 - 16³/₈"x16³/₈"

COLORI COLOURS COULEURS FARBEN

feel black



feel grey



feel silver



feel olive







feel beige



feel white

FORMATI SIZES FORMATS FORMATE

feel
ECOGRES

Formati Sizes Formats Formate	 cm 33x33 13"x13"	 cm 41,5x41,5 16 ³ / ₈ "x16 ³ / ₈ "	 cm 30x60 11 ³ / ₄ "x23 ⁵ / ₈ "
Feel Black G3*	●	●	●
Feel Grey G3*	●	●	●
Feel Silver G4*	●	●	●
Feel Olive G4*	●	●	●
Feel Beige G4*	●	●	●
Feel White G4*	●	●	●
	mm 8	mm 8	mm 8

* Vedi pagina: See page: Voir page: Siehe Seite: **503**

● Naturale Matt Naturelle Matt **R9**

Caratteristiche tecniche e imballi a pagina: Technical features and packing on page: Caractéristiques techniques et emballages à la page: Technische Eigenschaften und Verpackungen auf Seite: **506**

PEZZI SPECIALI TRIMS ACCESSOIRES FORMSTÜCKE

Battiscopa Bullnose
Plinthe à bord arrondi Stehsockel
cm 8x33 - 3¹/₂"x13"
cm 8x41,5 - 3¹/₂"x16³/₈"
cm 9x60 - 3¹/₂"x23⁵/₈"



Gradino Step tread
Nez de marche Stufenplatte
cm 30x60 - 11³/₄"x23⁵/₈"

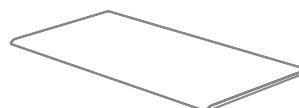

Gradino Step tread
Nez de marche Stufenplatte
cm 33x33 - 13"x13"

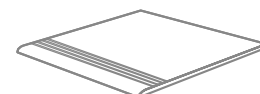

feel silver cm 30x60 - 11³/₄"x23⁵/₈"

living

ECOGRES



living brown cm 33x33 - 13"x13"

COLORI COLOURS COULEURS FARBEN

living black



living brown



living grey



living noisette





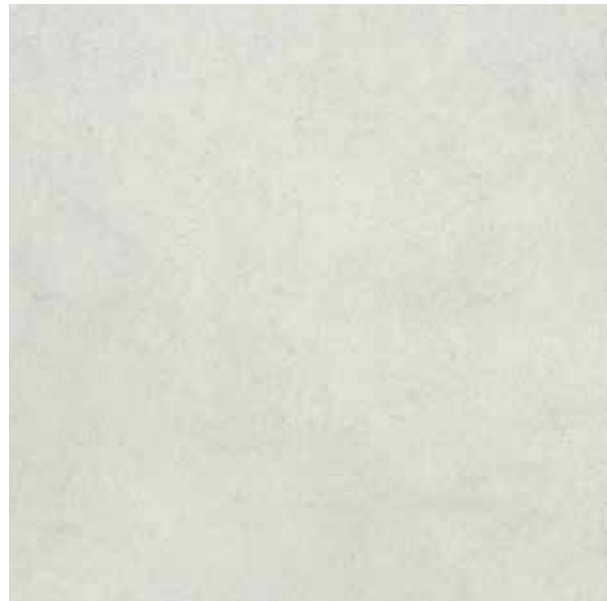

living beige



living ice

FORMATI SIZES FORMATS FORMATE

living
ECOGRES

Formati Sizes Formats Formate	 cm 33x33 13"x13"	 cm 41,5x41,5 16 ³ / ₈ "x16 ³ / ₈ "	 cm 30x60 1 ³ / ₄ "x23 ⁵ / ₈ "	 cm 60x60 23 ⁵ / ₈ "x23 ⁵ / ₈ "
Living Black G3*	●	●	●	●
Living Brown G3*	●	●	●	●
Living Grey G4*	●	●	●	●
Living Noisette G4*	●	●	●	●
Living Beige G4*	●	●	●	●
Living Ice G4*	●	●	●	●
Living White G4*	●	●	●	●
	mm 8	mm 8	mm 8	mm 9

* Vedi pagina: See pag: Voire pag: Siehe Seite: **503**

● Naturale Matt Naturelle Matt **R9**

Nel caso di combinazioni di formati di spessori diversi, specificarlo espressamente nell'ordine
Please specify in your order if you wish to purchase formats including more than one thickness
Prière de spécifier dans votre commande si vous souhaitez acheter des formats avec différentes épaisseurs
Bitte weisen Sie im Bestellungsformular ausdrücklich darauf hin, wenn Sie Formatkombinationen mit verschiedenen Stärken wünschen

Caratteristiche tecniche e imballi a pagina: Technical features and packing on page:
Caractéristiques techniques et emballages à la page: Technische Eigenschaften und Verpackungen auf Seite: **506**

PEZZI SPECIALI TRIMS ACCESSOIRES FORMSTÜCKE

Battiscopa Bullnose
Plinthe à bord arrondi Stehsockel
cm 8x33 - 3¹/₂"x13"
cm 8x41,5 - 3¹/₂"x16³/₈"
cm 9x60 - 3¹/₂"x23⁵/₈"



Gradino Step tread
Nez de marche Stufenplatte
cm 30x60 - 11³/₄"x23⁵/₈"

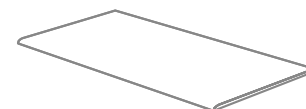

Gradino Step tread
Nez de marche Stufenplatte
cm 33x33 - 13"x13"

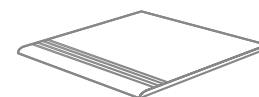

living white

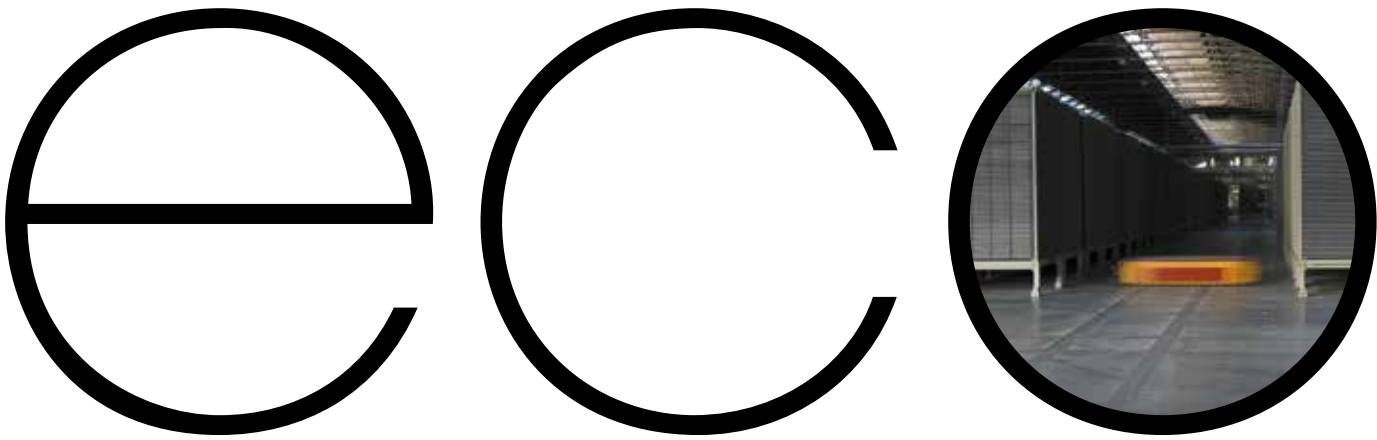

eco**technique** écot**technique** öko**technik**

tecnico

eco**tecnico**

476 **technic**

486 **tactile**

TECNICO

Materiale, prodotto, componente dotato di proprietà e caratteristiche prestazionali individuate o definite in rapporto alla sua origine e all'impiego a cui è destinato, che ne determinano il livello e il conseguente grado di specializzazione. Le proprietà e le caratteristiche sono valutabili secondo unità di misura, grandezze, capacità e procedure di prova rilevabili attraverso specifiche unanimemente condivise.

TECHNICAL

Material, product or component possessing properties and performance specifications identified or defined depending on their origin and the use for which they have been designed, and that determine their level and consequent degree of specialisation. The properties and characteristics can be evaluated according to units of measurement, magnitudes, capacities and test procedures established by universally accepted specifications.





technic

GRANITOGRES

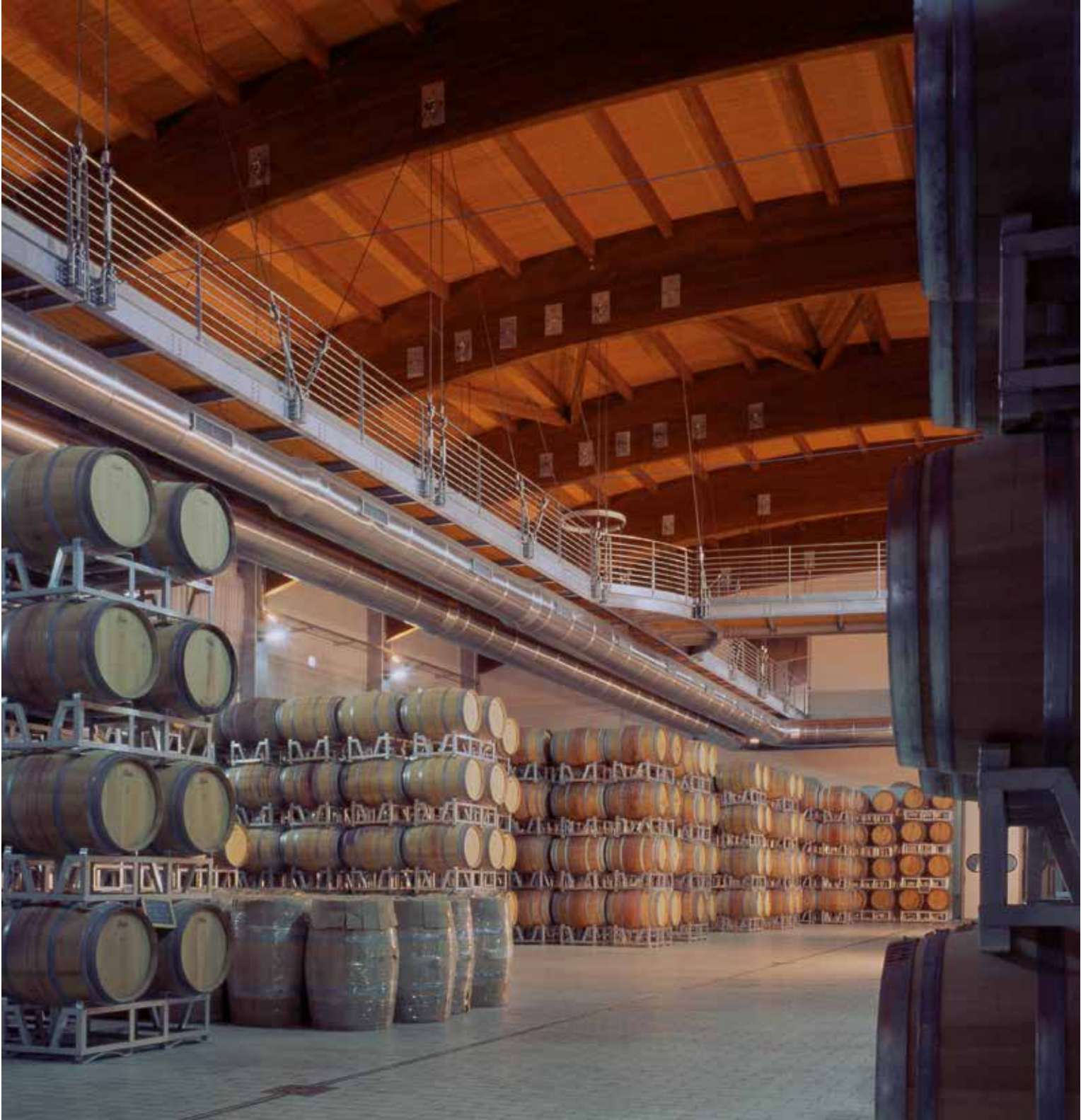

nebraska cm 20x20 - 77/8"x77/8"

COLORI COLOURS COULEURS FARBEN

grigio cenere



bianco avorio



bianco B



colorado



sahara



nebraska

technic

GRANITOGRES

ontario



arkansas

Landscape tundra 100 satin lucida



Landscape beach 101 satin

Rivestimenti smaltati
Glazed tiles
Revêtement émaillé
Fliesen aus glasiertem Feinsteinzeug

COLORI COLOURS COULEURS FARBEN

technic R10

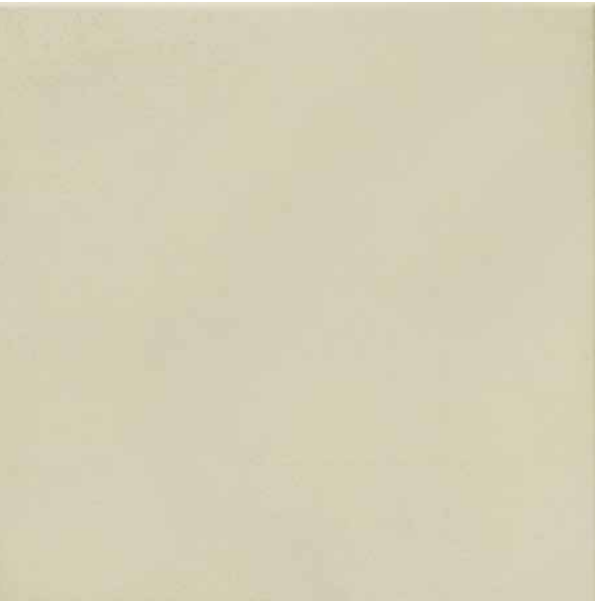

roccia R12 (A+B+C)



profil R12 - V8 (A+B+C)

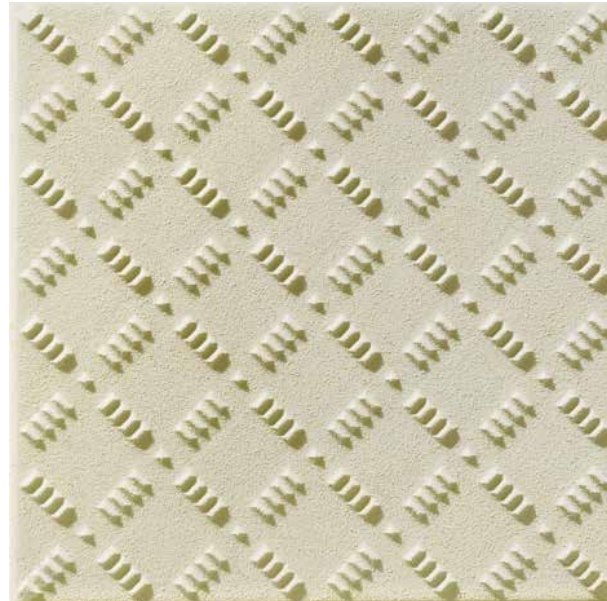

reticolo R12 - V4 (A+B+C)



carbo R12



sicura R11 (A+B)

technic

GRANITOGRES

bugnato R11 - V6 (A+B+C)

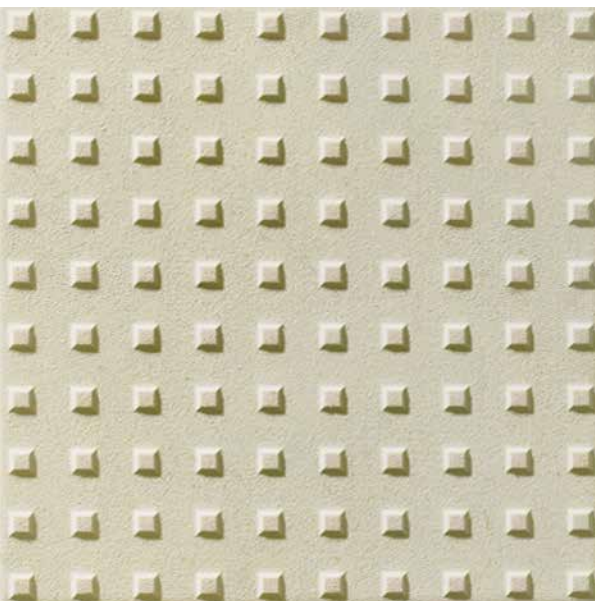



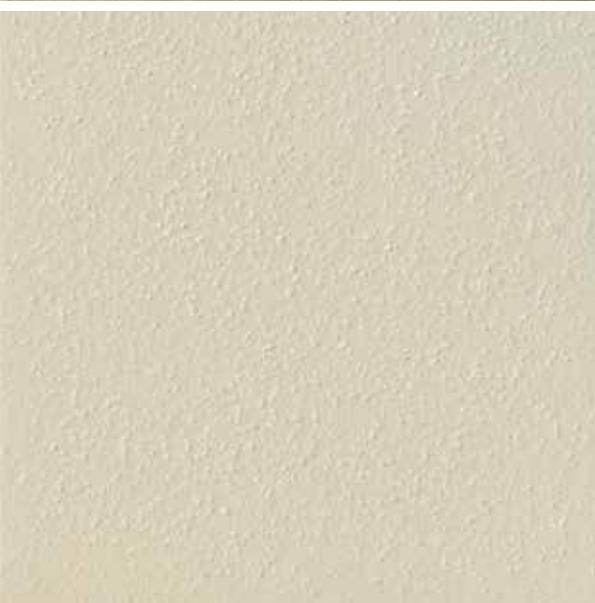





pavè R11 - V4 (A+B+C)



safe R13 (A+B+C)
agrèé par la CNAMTS

FORMATI SIZES FORMATS FORMATE

GRES PORCELLANATO NON SMALTATO UNGLAZED PORCELAIN STONEWARE GRÉS CÉRAME NON ÉMAILLÉ UNGLASIERTE FEINSTEINZEUGFLIESEN

Formati Sizes Formats Formate	 cm 15x15 5 ⁷ / ₈ "x5 ⁷ / ₈ "	 mm	 cm 20x20 7 ⁷ / ₈ "x7 ⁷ / ₈ "	 mm	 cm 12,5x25[▲] 4 ⁷ / ₈ "x 9 ⁷ / ₈ "	 mm	 cm 30x30 11 ³ / ₄ "x11 ³ / ₄ "	 mm
Roccia	■		■	8/12/14,2	■	8	■	8/11,2/14,2
Bugnato			■	8/12/14,2				
Profil	■	8	■	8/12/14,2				
Pavè			■	8/12/14,2	■	8		
Secura	■	8	■	8/12/14,2	■	8	■	8/11,2/14,2
Carbo			■	8,5/12*				
Technic	■	8	■	8/12/14,2	■	8	■	8/11,2/14,2
Reticolo	■	8	■	8/12/14,2**				
Safe			■	8/12***				

GRES PORCELLANATO SMALTATO GLAZED PORCELAIN STONEWARE GRÉS CÉRAME ÉMAILLÉ GLASIERTE FEINSTEINZEUGFLIESEN

Formati Sizes Formats Formate	 cm 12,5x25[▲] 4 ⁷ / ₈ "x 9 ⁷ / ₈ "
Satin	■ 8
Lucida	■ 8

▲ Dimensioni di fabbricazione 118x243. La modularità si ottiene con una fuga di 7mm
Factory size 118x243. For modular laying, install with a 7 mm joint
Dimensions de fabrication 118x243. Calpinage avec un joint de 7 mm
Fertigungsgröße 118x243. Die Modularität wird mit einer 7 mm Füge erzielt

* Produzione nei colori: Currently produced in the following colours:
Production dans les couleurs: Lieferbar in den Farben: **Bianco Avorio**

** Produzione nei colori: Currently produced in the following colours:
Production dans les couleurs: Lieferbar in den Farben: **Nebraska, Arkansas**

*** Produzione nei colori: Currently produced in the following colours:
Production dans les couleurs: Lieferbar in den Farben: **Bianco Avorio, Bianco B**

Caratteristiche tecniche e imballi a pagina: Technical features and packing on page: Caractéristiques techniques et emballages à la page: Technische Eigenschaften und Verpackungen auf Seite: **494**

PEZZI SPECIALI TRIMS ACCESSOIRES FORMSTÜCKE

Battiscopa Bullnose Plinthe à bord arrondi Stehsockel

cm 9x30 - 3¹/₂"x11³/₄"
cm 10x20 - 4"x7⁷/₈"

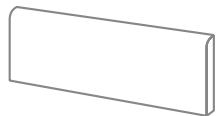

Gradino Step tread Nez de marche Stufenplatte

cm 30x30 - 11³/₄"x11³/₄"

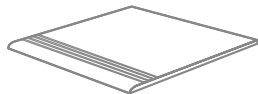

Sguscezza Cove Gorge Rinneleiste

cm 4x20 - 1¹/₂"x7⁷/₈"



Angolare Longitudinal angle Angulaire Schenkelplatte

cm 20x5x5 - 7⁷/₈"x2"x2"

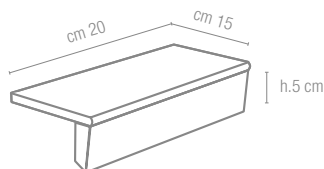

Zoccolo a raccordo a taglio retto

Cove base - straight top

Plinthe à gorge avec bord vif

Hohlkehlsoclel (scharfkantig)

cm 10x20 - 4"x7⁷/₈"

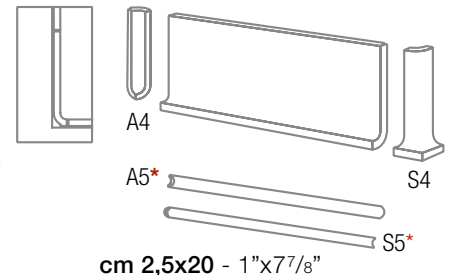

cm 2,5x20 - 1"x7⁷/₈"

Zoccolo ad appoggio smussato

Sit-on skirting - bevelled top

Plinthe à talon avec bord arrondi

Aufsetzsockel mit
abgerundeter Kante

cm 10x20 - 4"x7⁷/₈"

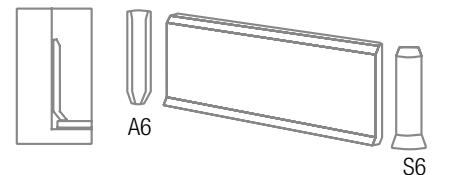

SUPERFICI SURFACES SURFACES OBERFLÄCHEN

technic

GRANITOGRES



14,2 mm

11,2/12 mm

8 mm

PEZZI SPECIALI **MODULO M 12,5x25** MODULAR TRIMS ACCESSOIRES MODULAIRES MODULAR FORMSTÜCKE

SISTEMA CANALETTA 1 CHANNEL SYSTEM 1 SYSTEME CANIVEAU 1 RINNESYSTEM 1

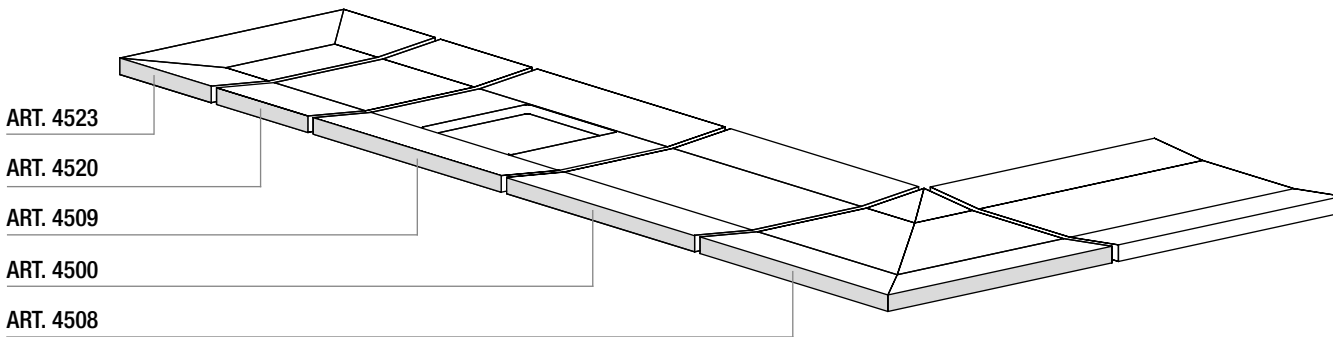

ART. 4523

ART. 4520

ART. 4509

ART. 4500

ART. 4508

ART. 4523

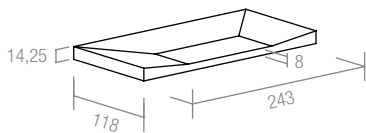

ART. 4520

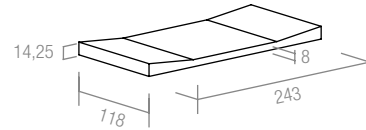

ART. 4509

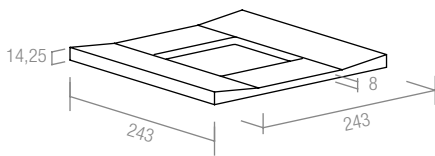

ART. 4500

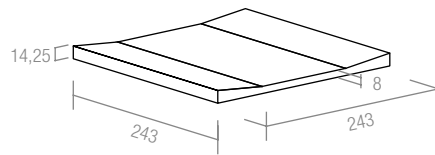

ART. 4508

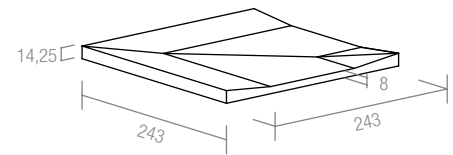

Produzione nei colori:
Currently produced
in the following
colours:
Production dans
les couleurs :
Lieferbar in den
Farben:
Bianco Avorio,
Bianco B
Superficie: Surface:
Surface : Oberfläche:
grip

SISTEMA CANALETTA 2 CHANNEL SYSTEM 2 SYSTEME CANIVEAU 2 RINNESYSTEM 2

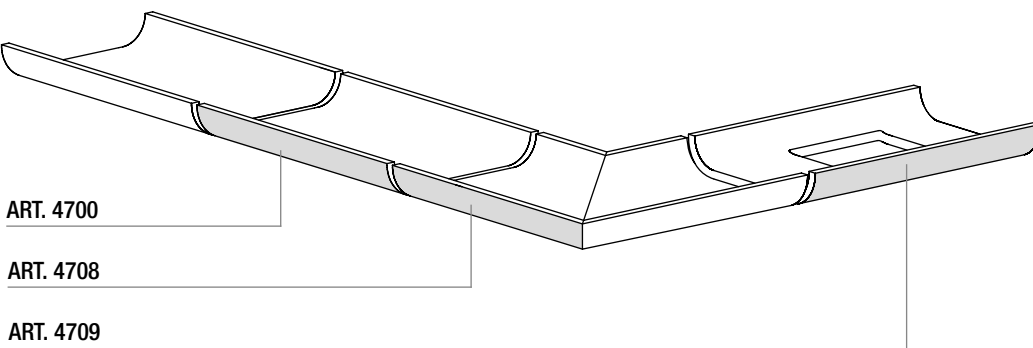

ART. 4700

ART. 4708

ART. 4709

ART. 4700

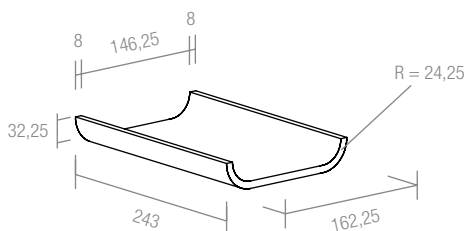

ART. 4708

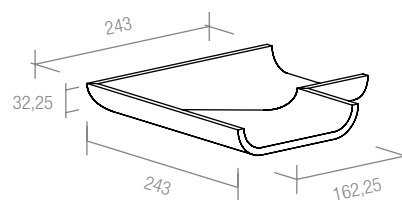

ART. 4709

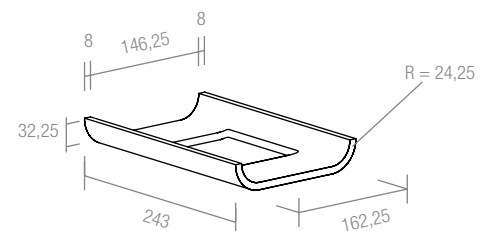

Produzione nei colori:
Currently produced
in the following
colours:
Production dans
les couleurs :
Lieferbar in den
Farben:
Tundra 100
Superficie: Surface:
Surface : Oberfläche:
satın

technic

GRANITOGRES

SISTEMA BECCO DI CIVETTA BULLNOSE SYSTEM SYSTEME BORD ARRONDI STEHSOCKELSYSTEM

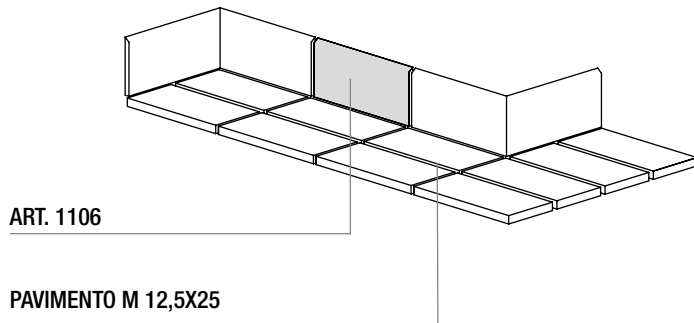

ART. 1106

PAVIMENTO M 12,5X25

Produzione nei colori:
Currently produced in the following colours:
Production dans les couleurs :
Lieferbar in den Farben:
Bianco Avorio, Bianco B
Superficie: Surface: Surface : Oberfläche: **matt**
Tundra 100, Beach 101
Superficie: Surface: Surface : Oberfläche: **satin**

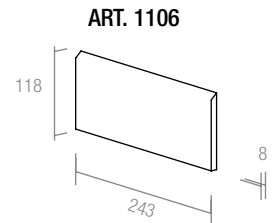

SISTEMA ZOCCOLO A RACCORDO SMUSSATO COVE BASE SYSTEM WITH BEVELLED TOP SYSTEME PLINTHE A GORGE BISEAUTE HOHKEHL SOCKELSYSTEM MIT ABGERUNDETER KANTE

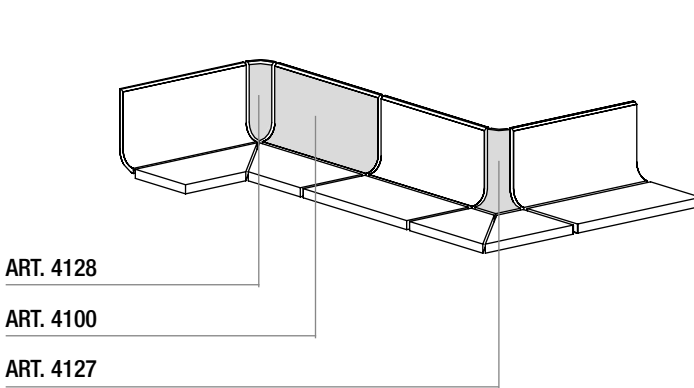

ART. 4128

ART. 4100

ART. 4127

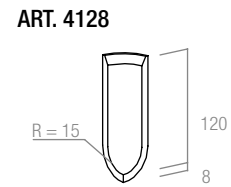
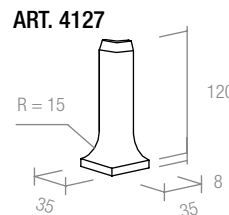

Produzione nei colori:
Currently produced in the following colours:
Production dans les couleurs :
Lieferbar in den Farben:
Bianco Avorio, Bianco B
Superficie: Surface: Surface : Oberfläche: **matt**
Tundra 100, Beach 101
Superficie: Surface: Surface : Oberfläche: **satin**

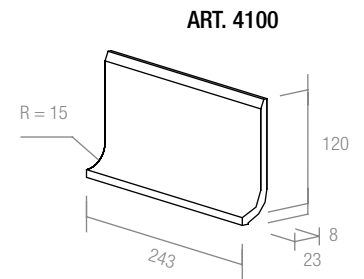

SISTEMA SGUSCETTA COVE SYSTEM SYSTEME GORGE RINNENLEISTESYSTEM

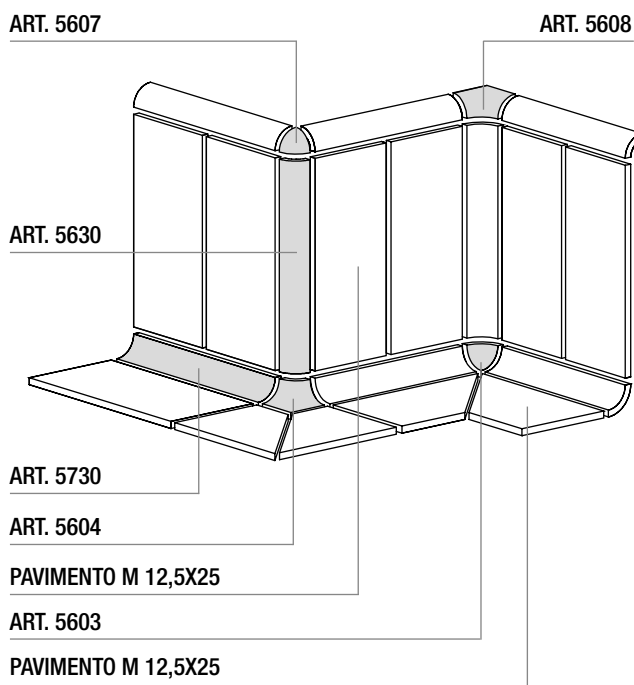

ART. 5607

ART. 5608

ART. 5630

ART. 5730

ART. 5604

PAVIMENTO M 12,5X25

ART. 5603

PAVIMENTO M 12,5X25

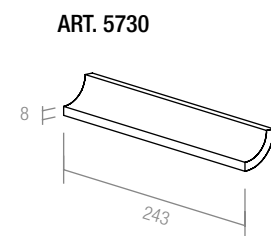
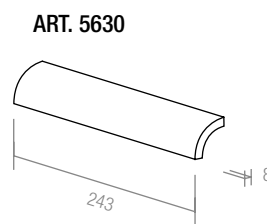

Produzione nei colori:
Currently produced in the following colours:
Production dans les couleurs :
Lieferbar in den Farben:
Bianco Avorio, Bianco B
Superficie: Surface: Surface : Oberfläche: **matt**
Tundra 100
Superficie: Surface: Surface : Oberfläche: **satin, lucida**
Beach 101
Superficie: Surface: Surface : Oberfläche: **satin**

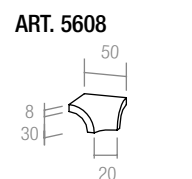
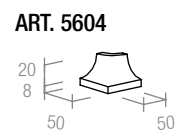
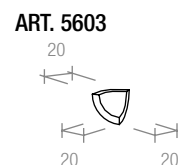

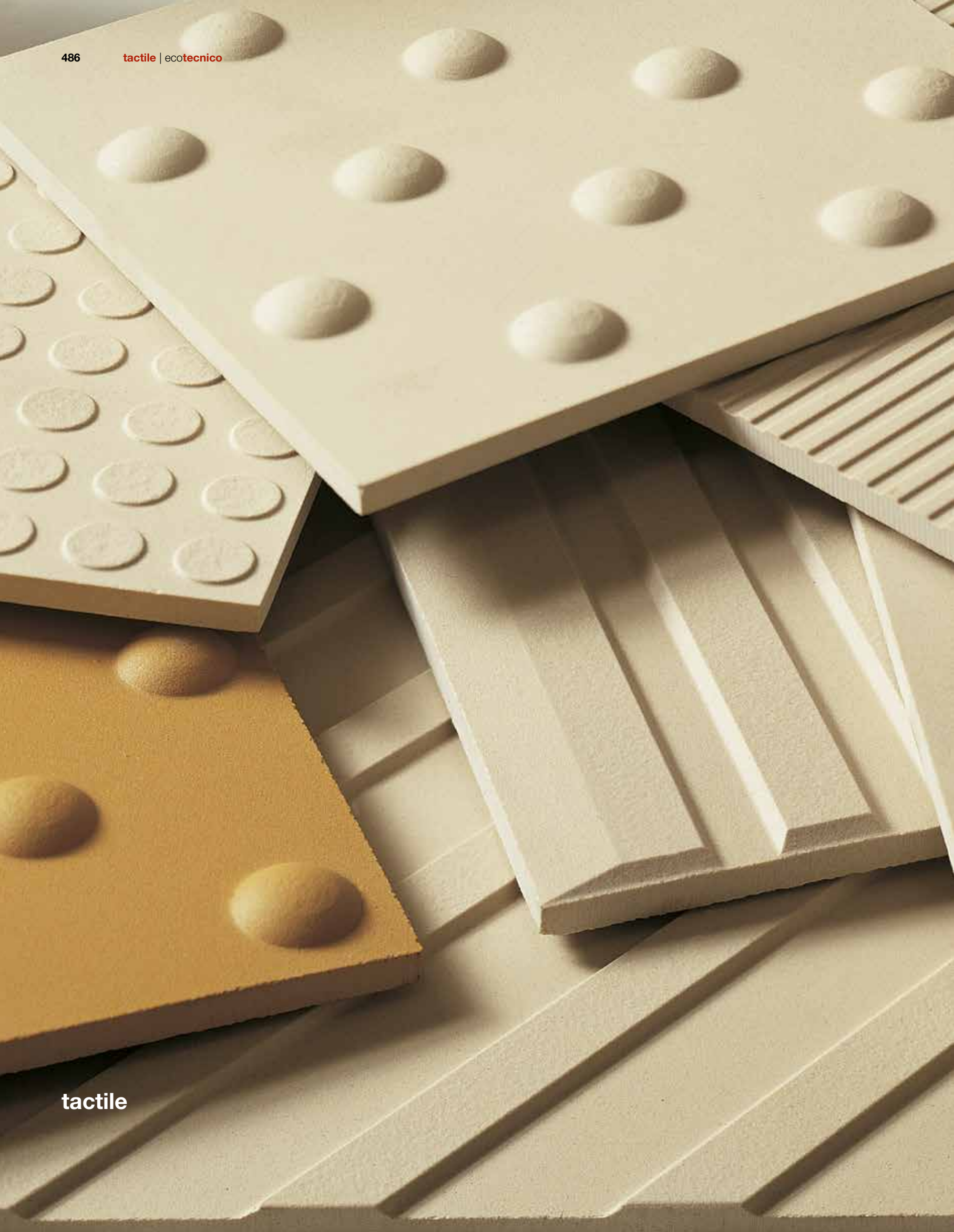

tactile

tactile

GRANITOGRES



tactile, ontario segura cm 30x30 - 11³/₄"x 11³/₄"

COLORI COLOURS COULEURS FARBEN

budapest



shanghai

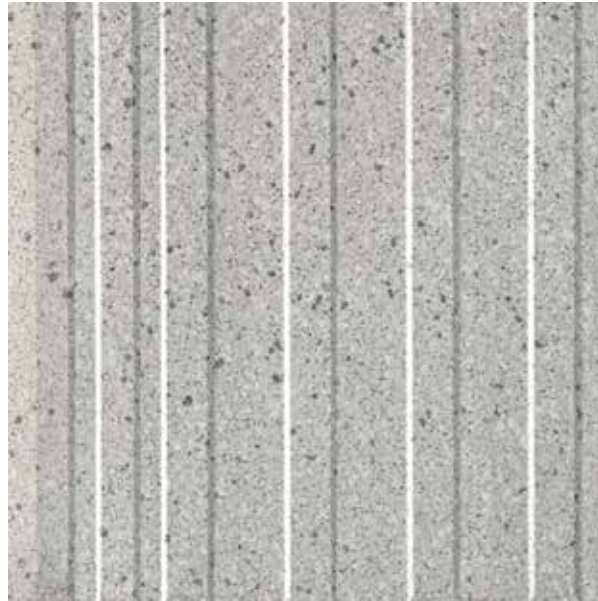

bianco avorio



madrid

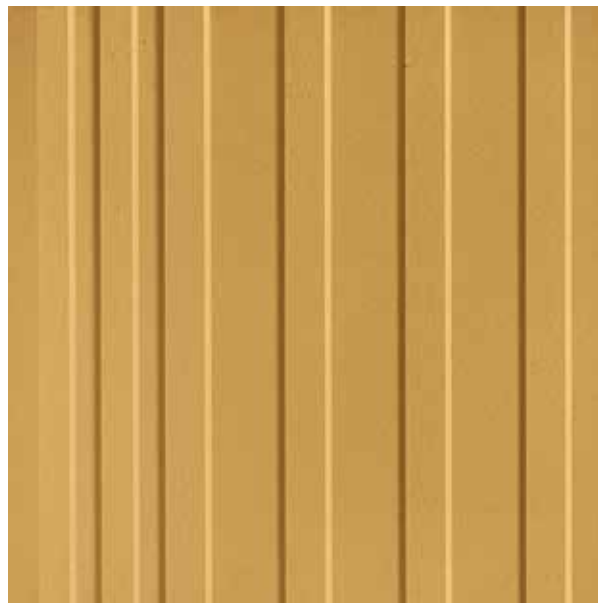

giallo ocra

Eventuali altri colori possono essere richiesti dal progettista per particolari esigenze architettoniche o progettuali.

Other colours may be requested by the designer for specific architectural or design needs.

D'autres couleurs peuvent être éventuellement demandées par le projeteur pour exigences architecturales ou projectuelles.

Evt. andere Farben können von Architekt, im Fall Von besondere Baubedürfnisse, nachgefragt werden.

PERCORSO GUIDA PER DISABILI VISIVI
 GUIDED PATH FOR VISUALLY DISABLED PEOPLE
 PARCOURS GUIDE POUR LES MALVOYANT ET AVEUGLES
 SEHEBEHINDERTLEITWEG

tactile
 GRANITOGRES

Codice di direzione rettilinea
 Straight direction code
 Code de direction rectiligne
 Geradlinige Richtung

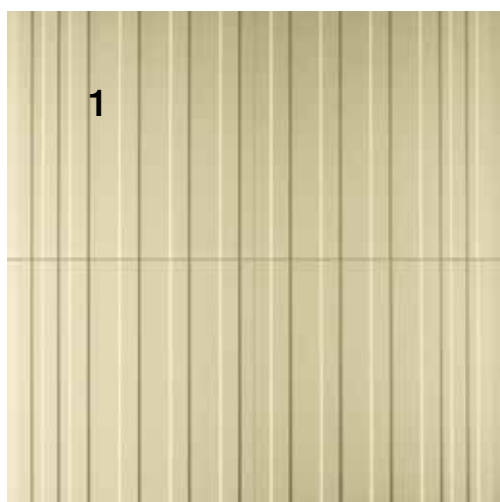

Codice di incrocio a T
 T-junction code
 Code de croisement en T
 T-förmige Kreuzung



Codice di svolta obbligata ad L
 Compulsory L-turn code
 Code de tournant obligatoire en L
 Obligatorisches L-förmiges Abbiegen

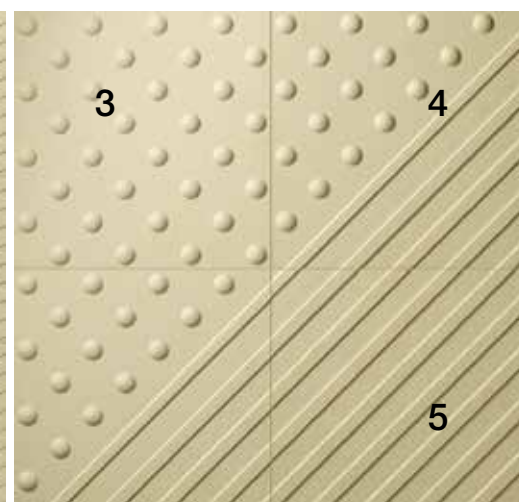

Codice di arresto-pericolo
 Stop-danger code
 Code d'arrêt-danger
 Stehenbleiben-Gefahr



Codice di pericolo valicabile
 Dangerous to pass code
 Code de danger franchissable
 Überwindbare Gefahr

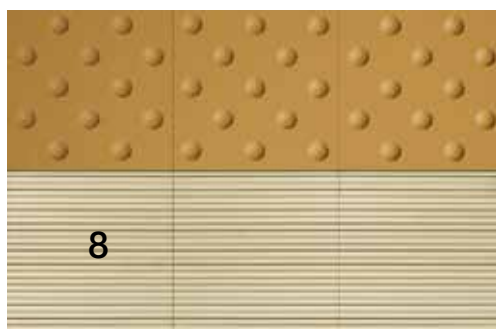

Codice di attenzione-servizio
 Attention-service code
 Code d'attention-service
 Achtung-Service



- 1. art. 30x30 rettilineo
- 2. art. 20x20 borchie
- 3. art. 30x30 tondi
- 4. art. 30x30 diagonale/tondi

- 5. art. 30x30 diagonale
- 6. art. 20x20 12 tondi
- 7. art. 20x20 13 tondi
- 8. art. 20x20 righe

e c o

utility

eco**utility**

caratteristiche tecniche

technical features

caractéristiques techniques

technische Eigenschaften

494 **granitogres**

498 **pietre native**

501 **granitoker**

504 **gresplus**

506 **ecogres**

508 **stonalizzazione**

shade variations

variations d'ombre

farbtonvarianten

509 **complementi
in acciaio e alluminio**

accessories in steel
and aluminium

**compléments en acier
et en aluminium**

zusatzelemente aus
Stahl und Aluminium

510 **voci di capitolato**

specifications

cahier des charges

ausschreibungstexte

512 **posa e manutenzione**

513 installation and maintenance

514 **pose et entretien**

515 verlegung und Pflege



CARATTERISTICHE TECNICHE TECHNICAL FEATURES CARACTÉRISTIQUES TECHNIQUES TECHNISCHE EIGENSCHAFTEN

GRANITOGRES



	NORMA STANDARDS NORME NORM	RISULTATO PROVA* TEST RESULTS* RESULTATS DES ESSAIS* ERGEBNISSE*
 classificazione prodotto product classification classement Klassifizierung	UNI EN 14411-G ISO 13006	gruppo B1a UGL completamente greificato group B1a UGL fully vitrified group B1a UGL grès cérame fin Gruppe B1a UGL Feinsteinzeug
 caratteristiche dimensionali e d'aspetto dimensional and surface quality caractéristiques de la surface Oberflächenqualität	UNI EN ISO 10545-2	tolleranze minime nella 1ª scelta very low tolerance des tolérances minimales en 1er choix Entspricht Normen
 assorbimento di acqua water absorption absorption d'eau Wasseraufnahme	UNI EN ISO 10545-3	< 0,1%
 resistenza alla flessione flexural strength résistance à la flexion Biegezug-Festigkeit	UNI EN ISO 10545-4	> 45 N/mm ²
 resistenza al gelo frost resistance résistance au gel Frostwiderstandsfähigkeit	qualsiasi norma all standards toute norme Alle normen	garantita guaranteed garantie Frostsicher
 resistenza attacco chimico (esclusione acido fluoridrico) resistance to acids and alkalis (with the exception of hydrofluoric acid) résistance à l'attaque chimique (exclusion de l'acide fluorhydrique) Säure und Laugen Beständigkeit (mit Ausnahme von Fluorwasserstoff)	UNI EN ISO 10545-13	nessuna alterazione no damage non attaquées Nicht angegriffen
 resistenza usura e abrasione wear and abrasion resistance résistance à l'usure et abrasion Abriebhärte	UNI EN ISO 10545-6	≤ 150 mm ³
 dilatazione termica lineare linear thermal expansion coefficient linéaire de dilatation thermique Lineare Wärmeausdehnung	UNI EN ISO 10545-8	6 x 10 ⁻⁶
 resistenza alle macchie stain resistance résistance aux taches Fleckenfestigkeit	UNI EN ISO 10545-14	garantita guaranteed garantie garantiert
 resistenza alla scivolosità (Superficie Naturale) slip resistance (Matt surface) résistance au glissement (Surface naturelle) Trittsicherheit (Natur Oberflächen)	DIN 51130 D.M. N° 236 del 14.06.89 Metodo B.C.R. BS7976-2:2002 BSEN13036-4:2011	vedere singole serie see every series voir les séries une par une Siehe einzelne Serie valore μ > 0,40**** PTV > 36****
 resistenza dei colori alla luce colour resistance to sunlight exposure résistance de la couleur à la lumière Unveränderlichkeit der Farben wenn Strahlung zugesetzt wird	DIN 51094	nessuna variazione no change of colours couleurs inchangées Keinerlei Farbänderung



**NORMA ASTM
ASTM STANDARDS**

**RISULTATO PROVA TEST RESULTS
RESULTATS DES ESSAIS ERGEBNISSE**

ASTM C-373 impervious ≤ 0,5%	< 0,1%**
ASTM C-648 breaking strength ≥ 250 lbf	425 lbf** 625 lbf***
ASTM C-1026 no sample must show alterations to surface	resistant
ASTM C-650 no sample must show alterations to surface	unaffected
ASTM C-1243 < 175 mm ³	≤ 150 mm ³
ASTM A137.1-2012 DCOF ≥ 0.42	see every series

* valore indicativo approx value
donnée approximative Ungefährhe Werte

** Test made on Granito 1, Arizona Matt



*** Test made on Marte Series

**** Prova su superficie asciutta Test on a dry surface
Essai sur surface sèche Test auf trockener Oberfläche

◆ Si rimanda all'elenco prodotti
UPEC ufficiale, consultabile sul sito:
Please see the official UPEC product list:
Veillez consulter la liste officielle produits UPEC:
Sihe die offizielle UPEC-Produktliste auf der Website:
<http://webapp.cstb.fr/upec-ceramique/>

PESI, MISURE E CONTENUTO DEI COLLI WEIGHT, SIZE AND CONTENTS OF THE PACKING POIDS, DIMENSIONS, CONTENU DES COLIS VERPACKUNGSGRÖSSEN/GEWICHTE

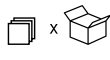
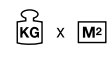
GRANITOGRES

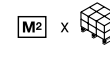
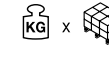
GRANITOGRES		 mm	 x	 x	 x 	 x	 x	 x
cm 10x20	4"x7 ⁷ / ₈ "	8	60	1,20	18,0	68	81,60	1.469
cm 12,5x12,5	4 ⁷ / ₈ "x4 ⁷ / ₈ "	8	64	1,00	17,0	72	72,00	1.224
cm 12,5x25	4 ⁷ / ₈ "x9 ⁷ / ₈ "	8	32	1,00	18,0	72	72,00	1.296
cm 12,5x25	4 ⁷ / ₈ "x9 ⁷ / ₈ " <i>Elementi</i>	8	32	1,00	17,0	78	78,00	1.326
cm 15x15	5 ⁷ / ₈ "x5 ⁷ / ₈ "	8	44	0,99	17,0	64	63,36	1.077
cm 15x15	5 ⁷ / ₈ "x5 ⁷ / ₈ "	9,4	40	0,90	21,6	64	57,60	1.244
cm 15x15	5 ⁷ / ₈ "x5 ⁷ / ₈ " <i>Natural Slate</i>	9	40	0,90	21,0	64	57,60	1.210
cm 15x30	5 ⁷ / ₈ "x11 ³ / ₄ "	8	22	0,99	18,0	64	63,36	1.140
cm 15x30	5 ⁷ / ₈ "x11 ³ / ₄ " <i>Natural Slate</i>	9	20	0,90	21,0	64	57,60	1.210
cm 15x60	5 ⁷ / ₈ "x23 ⁵ / ₈ "	9	12	1,08	21,0	40	43,20	907
cm 15x60	5 ⁷ / ₈ "x23 ⁵ / ₈ "	10	12	1,08	24,0	40	43,20	1.037
cm 15x60	5 ⁷ / ₈ "x23 ⁵ / ₈ "	9,4	12	1,08	21,6	40	43,20	933
cm 15x90	5 ⁷ / ₈ "x35 ³ / ₈ "	10	6	0,81	24,0	48	38,88	933
cm 20x20	7 ⁷ / ₈ "x7 ⁷ / ₈ "	8	30	1,20	18,0	68	81,60	1.469
cm 20x20	7 ⁷ / ₈ "x7 ⁷ / ₈ "	12	21	0,84	27,0	68	57,12	1.542
cm 20x20	7 ⁷ / ₈ "x7 ⁷ / ₈ "	14,2	18	0,72	32,0	51	36,72	1.175
cm 20x120	7 ⁷ / ₈ "x47 ¹ / ₄ "	10,5	4	0,96	25,0	42	40,32	1.008
cm 25x25	9 ⁷ / ₈ "x9 ⁷ / ₈ "	8	16	1,00	17,0	78	78,00	1.326
cm 30x30	11 ³ / ₄ "x11 ³ / ₄ "	7,6	14	1,26	17,5	48	60,48	1.058
cm 30x30	11 ³ / ₄ "x11 ³ / ₄ " <i>levigata polished</i>	8	14	1,26	17,0	48	60,48	1.028
cm 30x30	11 ³ / ₄ "x11 ³ / ₄ "	8	13	1,17	18,0	48	56,16	1.011
cm 30x30	11 ³ / ₄ "x11 ³ / ₄ "	8,2	13	1,17	19,0	48	56,16	1.067
cm 30x30	11 ³ / ₄ "x11 ³ / ₄ " <i>Natural Slate</i>	9	12	1,08	21,0	48	51,84	1.089
cm 30x30	11 ³ / ₄ "x11 ³ / ₄ " <i>non rettificato unrectified</i>	9	12	1,08	21,0	48	51,84	1.089
cm 30x30	11 ³ / ₄ "x11 ³ / ₄ " <i>levigata polished</i>	9,4	13	1,17	20,0	48	56,16	1.123
cm 30x30	11 ³ / ₄ "x11 ³ / ₄ "	9,4	12	1,08	21,6	48	51,84	1.120
cm 30x30	11 ³ / ₄ "x11 ³ / ₄ "	10	11	0,99	24,0	48	47,52	1.093
cm 30x30	11 ³ / ₄ "x11 ³ / ₄ " <i>levigata polished</i>	10,5	11	0,99	23,0	48	47,52	1.093
cm 30x30	11 ³ / ₄ "x11 ³ / ₄ "	11,2	10	0,90	26,0	48	43,20	1.123
cm 30x30	11 ³ / ₄ "x11 ³ / ₄ "	14,2	8	0,72	32,7	48	34,56	1.130
cm 30x60	11 ³ / ₄ "x23 ⁵ / ₈ "	9	6	1,08	21,0	48	51,84	1.089
cm 30x60	11 ³ / ₄ "x23 ⁵ / ₈ " <i>levigata polished</i>	9,4	6	1,08	20,0	48	51,84	1.037
cm 30x60	11 ³ / ₄ "x23 ⁵ / ₈ "	9,4	6	1,08	21,6	48	51,84	1.120
cm 30x60	11 ³ / ₄ "x23 ⁵ / ₈ " <i>levigata polished</i>	10	5	0,90	23,0	48	43,20	994
cm 30x60	11 ³ / ₄ "x23 ⁵ / ₈ "	10	5	0,90	24,0	48	43,20	1.037
cm 30x60	11 ³ / ₄ "x23 ⁵ / ₈ "	10,5	5	0,90	25,0	48	43,20	1.080
cm 40x40	15 ³ / ₄ "x15 ³ / ₄ "	9	8	1,28	21,0	48	61,44	1.290
cm 40x40	15 ³ / ₄ "x15 ³ / ₄ " <i>levigata polished</i>	9,4	8	1,28	19,0	48	61,44	1.167
cm 40x40	15 ³ / ₄ "x15 ³ / ₄ "	9,4	8	1,28	21,6	48	61,44	1.327
cm 45x45	17 ³ / ₄ "x17 ³ / ₄ "	9	5	1,01	21,6	34	34,41	743
cm 45x90	17 ³ / ₄ "x35 ³ / ₈ "	10	3	1,22	24,0	30	36,45	875
cm 60x60	23 ⁵ / ₈ "x23 ⁵ / ₈ "	10	4	1,44	24,0	30	43,20	1.037
cm 60x60	23 ⁵ / ₈ "x23 ⁵ / ₈ "	10,5	4	1,44	25,0	30	43,20	1.080
cm 60x120	23 ⁵ / ₈ "x47 ¹ / ₄ "	10	2	1,44	24,0	24	34,56	829
cm 60x120	23 ⁵ / ₈ "x47 ¹ / ₄ "	10,5	2	1,44	25,0	24	34,56	864
cm 90x90	35 ³ / ₈ "x35 ³ / ₈ "	10	2	1,62	24,0	24	38,88	933

GRANITOGRES



BATTISCOPIA B.C. BULLNOSE PLINTHE À BORD ARRONDI STEHSOCKEL

cm 9x30	3½"x11¾"	Agorà - Ardesia - Granito 1 Granito 1Evo - Granito 2 - Granito 3 Tiburino - Unicolore	30
cm 9x30	3½"x11¾"	Marmogres - Marte - Natural Slate Pietre Rare - Titano - Granito 2 Granito 3 - Tiburino - Unicolore	28
cm 9x40	3½"x15¾"		22
cm 9x45	3½"x17¾"		18
cm 9x60	3½"x23⅝"		18
cm 9x90	3½"x35⅜"		9
cm 10x20	4"x7⅞"		30

GRADINO STEP TREAD NEZ DE MARCHE STUFENPLATTE

cm 30x30	11¾"x11¾"		13
cm 30x30	11¾"x11¾"	levigata polished	14
cm 30x30	11¾"x11¾"	Marte - Natural Slate - Pietre Rare Titano	12
cm 30x30	11¾"x11¾"	levigata polished Marte - Pietre Rare - Titano	13
cm 30x60	11¾"x23⅝"	Marte - Pietre Rare - Titano	6

SCALINO

cm 40x33	16"x13"		4
----------	---------	--	---

SCALINO ANGOLARE

cm 40x33	16"x13"		3
----------	---------	--	---

GRADONE ASSEMBLATO

cm 30x33	11¾"x13"		4
cm 60x33	23⅝"x13"		4

ANGOLARE ASSEMBLATO

cm 60x33	23⅝"x13"		4
cm 60x33	23⅝"x13"		2

GRADONE RUSTICATO

cm 30x30	11¾"x11¾"		4
----------	-----------	--	---

GRADONE ANGOLARE RUSTICATO

cm 30x30	11¾"x11¾"		2
----------	-----------	--	---

GRADONE TORO

cm 60x33	23⅝"x13"		4
cm 60x33	23⅝"x13"	Con bordo antiscivolo Step treadstep with non-slip edging Marche avec nez antidérapant Stufenplatte mit rutschsicherer Kante	1
cm 120x33	47¼"x13"		4

ANGOLARE TORO

cm 60x33	23⅝"x13"		4
cm 120x33	47¼"x13"	Con bordo antiscivolo Step treadstep with non-slip edging Marche avec nez antidérapant Stufenplatte mit rutschsicherer Kante	2
cm 60x33	23⅝"x13"		4

ZOCCOLO SKIRTING PLINTHE HOHLKEHLSOCKEL

cm 10x20	4"x7⅞"		30
cm 10x30	4"x11¾"		30
cm 15x30	5⅞"x11¾"		12

SGUSCETTA COVE GORGE RINNLEISTE

cm 4x20	1½"x7⅞"		30
cm 2,5x10	1"x4"	A4 - S4	10
cm 2,5x20	1"x7⅞"	A5 - S5	60
cm 3x15	1"x5⅞"	A7 - S7	10

TOZZETTO INSERT CABOCHON EINLEGER

cm 9x9	3½"x3½"		35
cm 9x9	3½"x3½"	Marte - Pietre Rare - Titano	33

LISTELLO LISTEL LISTEL ZEIERLEISTE

cm 9x30	3½"x11¾"		30
cm 9x30	3½"x11¾"	Marte - Pietre Rare - Titano	28
cm 9x40	3½"x16"		22

TERMINALE STEP TREAD REBORD BECHKENRANDPLATTE

cm 15x30x3,5	6"x11¾"x1½"		6
--------------	-------------	--	---



CARATTERISTICHE TECNICHE TECHNICAL FEATURES CARACTÉRISTIQUES TECHNIQUES TECHNISCHE EIGENSCHAFTEN

PIETRE NATIVE



	NORMA STANDARDS NORME NORM	RISULTATO PROVA* TEST RESULTS* RESULTATS DES ESSAIS* ERGEBNISSE*
 classificazione prodotto product classification classement Klassifizierung	UNI EN 14411-G ISO 13006	gruppo B1a completamente greificato group B1a fully vitrified group B1a grès cérame fin Gruppe B1a Feinsteinzeug
 caratteristiche dimensionali e d'aspetto dimensional and surface quality caractéristiques de la surface Oberflächenqualität	UNI EN ISO 10545-2	tolleranze minime nella 1ª scelta very low tolerance des tolérances minimales en 1er choix Entspricht Normen
 assorbimento di acqua water absorption absorption d'eau Wasseraufnahme	UNI EN ISO 10545-3	< 0,1%
 resistenza alla flessione flexural strength résistance à la flexion Biegezug-Festigkeit	UNI EN ISO 10545-4	> 45 N/mm ²
 resistenza al gelo frost resistance résistance au gel Frostwiderstandsfähigkeit	qualsiasi norma all standards toute norme Alle normen	garantita guaranteed garantie Frostsicher
 resistenza attacco chimico (esclusione acido fluoridrico) resistance to acids and alkalis (with the exception of hydrofluoric acid) résistance à l'attaque chimique (exclusion de l'acide fluorhydrique) Säure und Laugen Beständigkeit (mit Ausnahme von Fluorwasserstoff)	UNI EN ISO 10545-13	nessuna alterazione no damage non attaquées Nicht angegriffen
 resistenza usura e abrasione wear and abrasion resistance résistance à l'usure et abrasion Abriebhärte	UNI EN ISO 10545-6	≤ 150 mm ³
 dilatazione termica lineare linear thermal expansion coefficient linéaire de dilatation thermique Lineare Wärmeausdehnung	UNI EN ISO 10545-8	6 x 10 ⁻⁶
 resistenza alle macchie stain resistance résistance aux taches Fleckenfestigkeit	UNI EN ISO 10545-14	garantita guaranteed garantie garantiert
 resistenza alla scivolosità (Superficie Naturale) slip resistance (Matt surface) résistance au glissement (Surface naturelle) Trittsicherheit (Natur Oberflächen)	DIN 51130 D.M. N° 236 del 14.06.89 Metodo B.C.R. BS7976-2:2002 BSEN13036-4:2011	vedere singole serie see every series voir les séries une par une Siehe einzelne Serie valore $\mu > 0,40^{**}$ PTV > 36 ^{**}
 resistenza dei colori alla luce colour resistance to sunlight exposure résistance de la couleur à la lumière Unveränderlichkeit der Farben wenn Strahlung zugesetzt wird	DIN 51094	nessuna variazione no change of colours couleurs inchangées Keinerlei Farbänderung

* valore indicativo approx value donnée approximative Ungefähre Werte











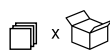

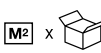
** Prova su superficie asciutta Test on a dry surface Essai sur surface sèche Test auf trockener Oberfläche





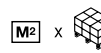





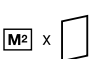

◆ Si rimanda all'elenco prodotti UPEC ufficiale, consultabile sul sito: Please see the official UPEC product list:

Veillez consulter la liste officielle produits UPEC: Sihe die offizielle UPEC-Produktliste auf der Website: <http://webapp.cstb.fr/upec-ceramique/>

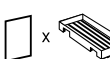
PESI, MISURE E CONTENUTO DEI COLLI WEIGHT, SIZE AND CONTENTS OF THE PACKING POIDS, DIMENSIONS, CONTENU DES COLIS VERPACKUNGSGRÖSSEN/GEWICHTE

PIETRE NATIVE

		 mm	 x 	 x 	 x 	 x 	 x 	 x 
cm 15x15	5 ⁷ / ₈ "x5 ⁷ / ₈ "	9	40	0,90	21,0	64	57,60	1.210
cm 15x60	5 ⁷ / ₈ "x23 ⁵ / ₈ "	9	12	1,08	21,0	40	43,20	907
cm 30x30	11 ³ / ₄ "x11 ³ / ₄ "	8	13	1,17	18	48	56,16	1.011
cm 30x30	11 ³ / ₄ "x11 ³ / ₄ "	9	12	1,08	21,0	48	51,84	1.089
cm 30x60	11 ³ / ₄ "x23 ⁵ / ₈ "	9	6	1,08	21	48	51,84	1.089
cm 30x60	11 ³ / ₄ "x23 ⁵ / ₈ "	10	5	0,9	24	48	43,2	1.037
cm 37,5x75,5	14 ¹ / ₂ "x3"	9	4	1,12	24	48	53,76	1.290
cm 37,5x75,5	14 ¹ / ₂ "x3"	10	4	1,12	24	48	53,76	1.290
cm 40x40	15 ³ / ₄ "x13 ³ / ₄ "	9	8	1,28	21	48	61,44	1.290
cm 45x45	17 ³ / ₄ "x17 ³ / ₄ "	4,9	10	2,03	11,3	34	68,85	778
cm 45x45	17 ³ / ₄ "x17 ³ / ₄ "	9	5	1,01	21,6	34	34,41	743
cm 45x45	17 ³ / ₄ "x17 ³ / ₄ "	10	5	1,01	24	34	34,41	826
cm 45x90	17 ³ / ₄ "x35 ³ / ₈ "	4,9	6	2,43	11,3	30	72,9	824
cm 45x90	17 ³ / ₄ "x35 ³ / ₈ "	20	2	0,81	44,5	26	21,06	937
cm 45x90	17 ³ / ₄ "x35 ³ / ₈ "	10	3	1,22	24,0	30	36,60	878
cm 60x60	23 ⁵ / ₈ "x23 ⁵ / ₈ "	4,9	8	2,88	11,3	30	86,4	976
cm 60x60	23 ⁵ / ₈ "x23 ⁵ / ₈ "	10	4	1,44	24	30	43,2	1.037
cm 60x60	23 ⁵ / ₈ "x23 ⁵ / ₈ "	20	2	0,72	46	32	23,04	1.060
cm 60x120	23 ⁵ / ₈ "x47 ¹ / ₄ "	4,9	4	2,88	11,3	24	69,12	781
cm 60x120	23 ⁵ / ₈ "x47 ¹ / ₄ "	6,5	3	2,16	15	24	51,84	778
cm 60x120	23 ⁵ / ₈ "x47 ¹ / ₄ "	10	2	1,44	24	24	34,56	829
cm 75,5x75,5	29 ³ / ₄ "x29 ³ / ₄ "	10	2	1,14	24	45	51,3	1.231
cm 90x90	35 ³ / ₈ "x35 ³ / ₈ "	10	2	1,62	24	24	38,88	933
cm 90x90	35 ³ / ₈ "x35 ³ / ₈ "	20	2	0,81	44,5	26	21,06	937
cm 90x180	35 ³ / ₈ "x70 ⁷ / ₈ "	10	1	1,62	24	30	48,6	1.166
cm 120x120	47 ¹ / ₄ "x47 ¹ / ₄ "	6,5	2	2,88	15	24	69,12	1.037
cm 120x120	47 ¹ / ₄ "x47 ¹ / ₄ "	10	1	1,44	24	30	43,2	1.037

		 mm		 x 	 x 	 x 	 x 	 x 
cm 120x240	47 ¹ / ₄ "x94 ¹ / ₂ "	6,5	1	2,88	15	20	57,6	864
cm 120x260	47 ¹ / ₄ "x102 ³ / ₈ "	6,5	1	3,12	15	20	62,4	936
cm 160x320	63"x126"	12	1	5,12	27	9	46,08	1.244

						 x 	 x 	 x 
cm 160x320	63"x126"	12	1	5,12	27	20	102,4	2.765

PESI, MISURE E CONTENUTO DEI COLLI WEIGHT, SIZE AND CONTENTS OF THE PACKING POIDS, DIMENSIONS, CONTENU DES COLIS VERPACKUNGSGRÖSSEN/GEWICHTE

PIETRE NATIVE



BATTISCOPA B.C. BULLNOSE

PLINTHE À BORD ARRONDI STEH SOCKEL

cm 9x30	3½"x11¾"	28
cm 9x40	3½"x16"	22
cm 9x45	3½"x18"	18
cm 9x60	3½"x23⅝"	18
cm 9x75,5	3½"x29¾"	8
cm 9x90	3½"x35⅝"	9

GRADINO STEP TREAD

NEZ DE MARCHE STUFENPLATTE

cm 30x30	11¾"x11¾"	12
cm 30x60	11¾"x23⅝"	6
cm 40x40	15¾"x15¾"	8
cm 45x45	17¾"x17¾"	5

SCALINO

cm 30x33	11¾"x13"	6
----------	----------	---

SCALINO ANGOLARE

cm 30x33	11¾"x13"	4
----------	----------	---

GRADONE ASSEMBLATO

cm 30x33	11¾"x13"	4
cm 60x33	23⅝"x13"	4
cm 120x33	47¼"x13"	2



ANGOLARE ASSEMBLATO

cm 30x33	11¾"x13"	2
cm 60x33	23⅝"x13"	3
cm 120x33	47¼"x13"	1

GRADONE PRESSATO

cm 30x33	11¾"x13"	4
----------	----------	---

ANGOLARE PRESSATO

cm 30x33	11¾"x13"	2
----------	----------	---

TOZZETTO INSERT CABOCHON EINLEGER

cm 9x9	3½"x3½"	33
--------	---------	----

LISTELLO LISTEL LISTEL ZEIERLEISTE

cm 9x30	3½"x11¾"	28
cm 9x45	3½"x17¾"	18

TERMINALE STEP TREAD REBORD BECHKENRANDPLATTE

cm 15x30x5	5⅞"x11¾"x2"	8
------------	-------------	---



CARATTERISTICHE TECNICHE TECHNICAL FEATURES CARACTÉRISTIQUES TECHNIQUES TECHNISCHE EIGENSCHAFTEN

GRANITOKER



PT0078

NORMA STANDARDS NORME NORM

RISULTATO PROVA* TEST RESULTS* RESULTATS DES ESSAIS* ERGEBNISSE*

	classificazione prodotto product classification classement Klassifizierung	UNI EN 14411-G ISO 13006	gruppo Bla completamente greificato group Bla fully vitrified group Bla grès cérame fin Gruppe Bla Feinsteinzeug
	caratteristiche dimensionali e d'aspetto dimensional and surface quality caractéristiques de la surface Oberflächenqualität	UNI EN ISO 10545-2	tolleranze minime nella 1 ^a scelta very low tolerance des tolérances minimales en 1er choix Entspricht Normen
	assorbimento di acqua water absorption absorption d'eau Wasseraufnahme	UNI EN ISO 10545-3	< 0,1%
	resistenza alla flessione flexural strength résistance à la flexion Biegezug-Festigkeit	UNI EN ISO 10545-4	> 45 N/mm ²
	resistenza al gelo frost resistance résistance au gel Frostwiderstandsfähigkeit	qualsiasi norma all standards toute norme Alle normen	garantita guaranteed garantie Frostsicher
	resistenza attacco chimico (esclusione acido fluoridrico) resistance to acids and alkalis (with the exception of hydrofluoric acid) résistance à l'attaque chimique (exclusion de l'acide fluorhydrique) Säure und Laugen Beständigkeit (mit Ausnahme von Fluorwasserstoff)	UNI EN ISO 10545-13	nessuna alterazione no damage non attaquées Nicht angegriffen
	resistenza usura e abrasione wear and abrasion resistance résistance à l'usure et abrasion Abriebhärte	UNI EN ISO 10545-6	≤ 150 mm ³
	dilatazione termica lineare linear thermal expansion coefficient linéaire de dilatation thermique Lineare Wärmeausdehnung	UNI EN ISO 10545-8	6 x 10 ⁻⁶
	resistenza alle macchie stain resistance résistance aux taches Fleckenfestigkeit	UNI EN ISO 10545-14	garantita guaranteed garantie garantiert
	resistenza alla scivolosità (Superficie Naturale) slip resistance (Matt surface) résistance au glissement (Surface naturelle) Trittsicherheit (Natur Oberflächen)	DIN 51130 D.M. N° 236 del 14.06.89 Metodo B.C.R. BS7976-2:2002 BSEN13036-4:2011	vedere singole serie see every series voir les séries une par une Siehe einzelne Serie valore $\mu > 0,40^*$ PTV > 36 ^{**}
	resistenza dei colori alla luce colour resistance to sunlight exposure résistance de la couleur à la lumière Unveränderlichkeit der Farben wenn Strahlung zugesetzt wird	DIN 51094	nessuna variazione no change of colours couleurs inchangées Keinerlei Farbänderung

* valore indicativo approx value donnée approximative Ungefähre Werte



** Prova su superficie asciutta Test on a dry surface Essai sur surface sèche Test auf trockener Oberfläche

◆ Si rimanda all'elenco prodotti UPEC ufficiale, consultabile sul sito: Please see the official UPEC product list:



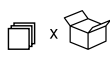
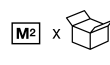
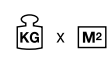
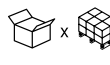
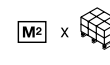

Veuillez consulter la liste officielle produits UPEC: Sihe die offizielle UPEC-Produktliste auf der Website: <http://webapp.cstb.fr/upec-ceramique/>

PESI, MISURE E CONTENUTO DEI COLLI WEIGHT, SIZE AND CONTENTS OF THE PACKING POIDS, DIMENSIONS, CONTENU DES COLIS VERPACKUNGSGRÖSSEN/GEWICHTE

GRANITOKER

		 mm	 x	 M ² x	 KG x M ²	 x	 M ² x	 KG x
cm 9,8x59	37/8"x231/4"	10	18	1,04	24,0	48	49,92	1.198
cm 10x60	4"x235/8"	9	18	1,08	21,0	48	51,84	1.089
cm 11x90	43/8"x353/8"	10	9	0,89	24,0	50	44,55	1.069
cm 15x60	57/8"x235/8" <i>non rettificato unrectified</i>	8	14	1,26	19,5	40	50,40	983
cm 15x90	57/8"x353/8" <i>non rettificato unrectified</i>	8	7	0,95	19,5	48	45,60	885
cm 15x90	57/8"x353/8"	10	6	0,81	24,0	48	38,88	933
cm 15x120	57/8"x471/4"	10	5	0,90	24,0	48	43,20	1.037
cm 20x20	77/8"x77/8"	9	28	1,12	21,0	68	76,16	1.699
cm 20x120	77/8"x471/4"	10	4	0,96	24,0	42	40,32	968
cm 20x120	77/8"x471/4"	6,5						
cm 20x240	77/8"x941/4"	6,5						
cm 22,5x90	87/8"x353/8"	10	5	1,01	24,0	54	54,65	1.312
cm 22,5x180	87/8"x707/8"	10	3	1,22	24,0	40	48,80	1.171
cm 25x151	97/8"x591/2"	10	3	1,13	24,0	48	54,24	1.301
cm 29,5x59	115/8"x231/4"	10	5	0,87	24,0	48	41,76	1.002
cm 29,5x118	115/8"x461/2"	10	3	1,04	24,0	36	37,44	899
cm 30x30	113/4"x113/4"	10	11	0,99	24,0	48	47,52	1.140
cm 30x60	113/4"x235/8" <i>non rettificato unrectified</i>	9	6	1,08	21,0	48	51,84	1.089
cm 30x60	113/4"x235/8"	10	6	1,08	24,0	48	43,20	1.037
cm 30x60	113/4"x235/8"	9	6	1,08	21,0	48	51,84	1.089
cm 30x120	113/4"x471/4"	10	3	1,08	24,0	36	38,88	933
cm 30x120	113/4"x471/4"	6,5						
cm 30x240	113/4"x941/2"	6,5	-					
cm 30x180	113/4"x707/8"	10	2	1,08	24,0	45	48,60	1.166
cm 37,5x75,5	141/2"x293/4"	9	4	1,13	21,0	54	61,02	1.281
cm 37,5x75,5	141/2"x293/4"	10	4	1,13	24,0	48	54,24	1.302
cm 40x120	153/4"x471/4"	20	2	0,96	47,0	32	30,72	1.444
cm 41,5x41,5	163/8"x163/8"	8,8	8	1,38	19,5	48	66,14	1.290
cm 45x90	173/4"x353/8"	10	3	1,22	24,0	30	36,60	878
cm 45x90	173/4"x353/8"	10,5	3	1,22	25,0	30	36,45	911
cm 45x180	173/4"x707/8"	10	1	0,81	24,0	30	24,30	583
cm 59x59	231/4"x231/4"	10	4	1,39	24,0	30	41,70	1.001
cm 59x118	231/4"x461/2"	6,5	3	2,09	15,0	24	50,11	752
cm 59x118	231/4"x461/2"	10	2	1,39	24,0	24	33,36	801
cm 60x60	235/8"x235/8"	10	4	1,44	25,0	30	43,20	1.080
cm 60x60	235/8"x235/8"	20	2	0,72	46,0	32	23,04	1.060
cm 60x120	235/8"x471/4"	10	2	1,44	24,0	24	34,56	829
cm 75,5x75,5	293/4"x293/4"	10	2	1,14	24,0	45	51,30	1.231
cm 75,5x151	293/4"x291/2"	10	2	2,28	24,0	22	50,16	1.204
cm 90x90	353/8"x353/8"	10	2	1,62	24,0	24	38,88	933

GRANITOKER

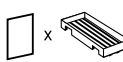
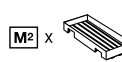
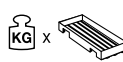
								
cm 118x236	46 ¹ / ₂ "x92 ⁷ / ₈ "	6,5	1	2,78	15	20	55,58	835
cm 118x258	46 ¹ / ₂ "x101 ⁵ / ₈ "	6,5	1	3,04	15	20	60,88	913
cm 120x240	47 ¹ / ₄ "x94 ¹ / ₂ "	6,5	1	2,88	15	20	57,6	864
cm 120x260	47 ¹ / ₄ "x102 ³ / ₈ "	6,5	1	3,12	15	20	62,4	936
cm 160x320	63"x126"	12	1	5,12	27	9	46,08	1.244
cm 160x320	63"x126"	12	1	5,12	27	20	102,4	2.765

		
BATTISCOPIA B.C. BULLNOSE		
PLINTE À BORD ARRONDI STEH SOCKEL		
cm 7,5x60	3"x23 ⁵ / ₈ "	18
cm 9x59	3 ¹ / ₄ "x23 ⁵ / ₈ "	18
cm 9x60	3 ¹ / ₄ "x23 ⁵ / ₈ "	18
cm 9x75,5	3 ¹ / ₄ "x29 ³ / ₄ "	8
cm 9x90	3 ¹ / ₄ "x35 ³ / ₈ "	9
cm 9x120	3 ¹ / ₄ "x47 ¹ / ₄ "	8
cm 9x180	3 ¹ / ₂ "x70 ⁷ / ₈ "	4

GRADINO STEP TREAD		
NEZ DE MARCHE STUFENPLATTE		
cm 29,5x59	11 ⁵ / ₈ "x23 ¹ / ₄ "	6
cm 30x60	11 ³ / ₄ "x23 ⁵ / ₈ "	6
cm 30x90	11 ³ / ₄ "x35 ³ / ₈ "	4
cm 30x120	11 ³ / ₄ "x47 ¹ / ₄ "	3
cm 37,5x75,5	14 ³ / ₄ "x29 ³ / ₄ "	4

ESAGONO		
cm 30x51,9	11 ³ / ₄ "x20 ³ / ₈ "	4

CHEVRON A		
cm 31x29,5	12 ¹ / ₄ "x11 ⁵ / ₈ "	6

CHEVRON B		
cm 14,6x50	5 ³ / ₄ "x19 ³ / ₄ "	12

GRADONE ASSEMBLATO		
cm 60x33	23 ⁵ / ₈ "x13"	4
cm 75,5x33	29 ³ / ₄ "x13"	-
cm 118x33	46 ¹ / ₂ "x13"	2
cm 120x33	47 ¹ / ₄ "x13"	2
cm 180x33	70 ⁷ / ₈ "x13"	-

		
ANGOLARE ASSEMBLATO		
cm 60x33	23 ⁵ / ₈ "x13"	2
cm 75,5x33	29 ³ / ₄ "x13"	-
cm 90x33	35 ³ / ₈ "x13"	1
cm 118x33	46 ¹ / ₂ "x13"	1
cm 120x33	47 ¹ / ₄ "x13"	1
cm 180x33	70 ⁷ / ₈ "x13"	-

TOZZETTO INSERT CABOCHON EINLEGER		
cm 9,8x9,8	37 ⁸ / ₈ "x37 ⁸ / ₈ "	33

BORDO		
cm 20x120	7 ⁷ / ₈ "x47 ¹ / ₄ "	2
cm 33x120	13"x47 ¹ / ₄ "	2

BORDO ANG. ESTERNO		
cm 20x60	7 ⁷ / ₈ "x23 ⁵ / ₈ "	2
cm 33x60	13"x23 ⁵ / ₈ "	2

BORDO ANG. INTERNO		
cm 20x60	7 ⁷ / ₈ "x23 ⁵ / ₈ "	2
cm 33x60	13"x23 ⁵ / ₈ "	2

GRIGLIA		
cm 30x40	11 ³ / ₄ "x15 ³ / ₄ "	4
cm 13x40	5 ¹ / ₈ "x15 ³ / ₄ "	8

GRIGLIA ANGOLARE		
cm 30x40	11 ³ / ₄ "x15 ³ / ₄ "	4
cm 13x40	5 ¹ / ₈ "x15 ³ / ₄ "	8



CARATTERISTICHE TECNICHE TECHNICAL FEATURES CARACTÉRISTIQUES TECHNIQUES TECHNISCHE EIGENSCHAFTEN

GRESPLUS



	NORMA STANDARDS NORME NORM	RISULTATO PROVA* TEST RESULTS* RESULTATS DES ESSAIS* ERGEBNISSE*
 classificazione prodotto product classification classement Klassifizierung	UNI EN 14411-G ISO 13006	gruppo Bla completamente greificato group Bla fully vitrified group Bla grès cérame fin Gruppe Bla Feinsteinzeug
 caratteristiche dimensionali e d'aspetto dimensional and surface quality caractéristiques de la surface Oberflächenqualität	UNI EN ISO 10545-2	tolleranze minime nella 1ª scelta very low tolerance des tolérances minimales en 1er choix Entspricht Normen
 assorbimento di acqua water absorption absorption d'eau Wasseraufnahme	UNI EN ISO 10545-3	< 0,1%
 resistenza alla flessione flexural strength résistance à la flexion Biegezug-Festigkeit	UNI EN ISO 10545-4	> 45 N/mm ²
 resistenza al gelo frost resistance résistance au gel Frostwiderstandsfähigkeit	qualsiasi norma all standards toute norme Alle normen	garantita guaranteed garantie Frostsicher
 resistenza attacco chimico (esclusione acido fluoridrico) resistance to acids and alkalis (with the exception of hydrofluoric acid) résistance à l'attaque chimique (exclusion de l'acide fluorhydrique) Säure und Laugen Beständigkeit (mit Ausnahme von Fluorwasserstoff)	UNI EN ISO 10545-13	GA
 dilatazione termica lineare linear thermal expansion coefficient linéaire de dilatation thermique Lineare Wärmeausdehnung	UNI EN ISO 10545-8	6 x 10 ⁻⁶
 resistenza alle macchie stain resistance résistance aux taches Fleckenfestigkeit	UNI EN ISO 10545-14	garantita guaranteed garantie garantiert
 resistenza alla scivolosità (Superficie Naturale) slip resistance (Matt surface) résistance au glissement (Surface naturelle) Trittsicherheit (Natur Oberflächen)	DIN 51130 D.M. N° 236 del 14.06.89 Metodo B.C.R. BS7976-2:2002 BSEN13036-4:2011	vedere singole serie see every series voir les séries une par une Siehe einzelne Serie valore $\mu > 0,40^{**}$ PTV > 36 ^{**}
 resistenza dei colori alla luce colour resistance to sunlight exposure résistance de la couleur à la lumière Unveränderlichkeit der Farben wenn Strahlung zugesetzt wird	DIN 51094	nessuna variazione no change of colours couleurs inchangées Keinerlei Farbänderung

* valore indicativo approx value donnée approximative Ungefähre Werte











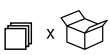

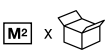
** Prova su superficie asciutta Test on a dry surface Essai sur surface sèche Test auf trockener Oberfläche

◆ Si rimanda all'elenco prodotti UPEC ufficiale, consultabile sul sito: Please see the official UPEC product list:

Veillez consulter la liste officielle produits UPEC: Sihe die offizielle UPEC-Produktliste auf der Website: <http://webapp.cstb.fr/upec-ceramique/>

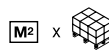
PESI, MISURE E CONTENUTO DEI COLLI WEIGHT, SIZE AND CONTENTS OF THE PACKING POIDS, DIMENSIONS, CONTENU DES COLIS VERPACKUNGSGRÖSSEN/GEWICHTE

GRESPLUS

	 mm	 x 	 x 	 x 	 x 	 x 	 x 	
cm 6,25x25	2 ¹ / ₂ "x 9 ⁷ / ₈ "	8	64	1,00	17,0	72	72,00	1.224
cm 12,5x12,5	4 ⁷ / ₈ "x4 ⁷ / ₈ "	8	64	1,00	17,0	72	72,00	1.224
cm 12,5x25	4 ⁷ / ₈ "x9 ⁷ / ₈ "	8	32	1,00	17,0	78	78,00	1.326
cm 20x20	7 ⁷ / ₈ "x7 ⁷ / ₈ "	8	30	1,20	18,0	68	81,60	1.469
cm 25x25	9 ⁷ / ₈ "x9 ⁷ / ₈ "	8	16	1,00	17,0	78	78,00	1.326
cm 20x40	7 ⁷ / ₈ "x15 ³ / ₄ "	8	18	1,44	18,0	56	80,64	1.452
cm 30x60	11 ³ / ₄ "x23 ⁵ / ₈ "	8	6	1,08	18,0	48	51,84	933
cm 30x60	11 ³ / ₄ "x23 ⁵ / ₈ "	9	6	1,08	21,0	48	51,84	1.089
cm 41,5x41,5	16 ³ / ₈ "x16 ³ / ₈ "	8,8	8	1,38	19,5	48	66,14	1.290
cm 45x45	17 ³ / ₄ "x17 ³ / ₄ "	8	5	1,01	18,0	34	34,41	1.290
cm 60x60	23 ⁵ / ₈ "x23 ⁵ / ₈ "	9	2	0,72	21,0	32	23,04	1.290
cm 60x60	23 ⁵ / ₈ "x23 ⁵ / ₈ "	20	2	0,72	46,0	32	23,04	1.060

BATTISCOPIA B.C. BULLNOSE PLINTHE À BORD ARRONDI STEH SOCKEL

cm 9x40	3 ¹ / ₂ "x16"	22
cm 9x45	3 ¹ / ₂ "x17 ³ / ₄ "	18
cm 9x60	3 ¹ / ₂ "x23 ⁵ / ₈ "	18

GRADINO STEP TREAD NEZ DE MARCHE STUFENPLATTE

cm 30x60	11 ³ / ₄ "x23 ⁵ / ₈ "
-----------------	---

TERMINALE PEZZO UNICO PRESSATO

cm 15x30x3,5	5 ⁷ / ₈ "x11 ³ / ₄ "x1 ³ / ₈ "	6
---------------------	--	---

CLASSIFICAZIONE DELLE PIASTRELLE DA PAVIMENTO IN BASE ALL'AMBIENTE DI DESTINAZIONE CLASSIFICATION OF THE FLOOR TILES ACCORDING TO THE FINAL DESTINATION CLASSIFICATION DES CARREAUX SELON L'ENTROIT DESTINE KLASSIFIZIERUNG DER BODENFLIESE NACH IHREM VERWENDUNGSZWECK

G1 Gruppo 1: Traffico leggero (bagni, camere da letto)

Group 1: Light wear (bathrooms, bedrooms)

Groupe 1: Trafic léger (salles de bains, chambres à coucher)

Gruppe 1: Leichte Beanspruchung (Bade und Schlafzimmer)

G2 Gruppo 2: Traffico-medio (appartamenti privati ad esclusione cucine)

Group 2: Medium wear (private apartments, kitchens excluded)

Groupe 2: Trafic moyen (appartements privés sauf cuisines)

Gruppe 2: Beanspruchung (Privatwohnungen außer Küchen)

G3 Gruppo 3: Traffico medio-forte (appartamenti, case private)

Group 3: Medium hard wear (flats and private houses)

Groupe 3: Trafic mi-fort (appartements et maisons)

Gruppe 3: Mittlere Beanspruchung (Wohnungen und Privathäuser)

G4 Gruppo 4: Traffico forte (ristoranti, uffici, edifici pubblici)

Group 4: Hard wear (restaurants, offices, public buildings)

Groupe 4: Trafic fort (restaurants, bureaux, édifices publics)

Gruppe 4: Starke Beanspruchung (Restaurant, Büros, öffentliche Gebäude)



CARATTERISTICHE TECNICHE TECHNICAL FEATURES CARACTÉRISTIQUES TECHNIQUES TECHNISCHE EIGENSCHAFTEN









ECOGRES



PT0130

**NORMA STANDARDS
NORME NORM**

**RISULTATO PROVA* TEST RESULTS*
RESULTATS DES ESSAIS* ERGEBNISSE***

	classificazione prodotto product classification classement Klassifizierung	UNI EN 14411-G ISO 13006	gruppo Blb GL completamente greificato group Blb GL fully vitrified group Blb GL grès cérame fin Gruppe Blb GL Feinsteinzeug
	caratteristiche dimensionali e d'aspetto dimensional and surface quality caractéristiques de la surface Oberflächenqualität	UNI EN ISO 10545-2	tolleranze minime nella 1ª scelta very low tolerance des tolérances minimales en 1er choix Entspricht Normen
	resistenza alla flessione flexural strength résistance à la flexion Biegezug-Festigkeit	UNI EN ISO 10545-4	35 ÷ 40 N/mm ²
	resistenza al gelo frost resistance résistance au gel Frostwiderstandsfähigkeit	qualsiasi norma all standards toute norme Alle normen	garantita guaranteed garantie Frostsicher
	resistenza attacco chimico (esclusione acido fluoridrico) resistance to acids and alkalis (with the exception of hydrofluoric acid) résistance à l'attaque chimique (exclusion de l'acide fluorhydrique) Säure und Laugen Beständigkeit (mit Ausnahme von Fluorwasserstoff)	UNI EN ISO 10545-13	GA
	dilatazione termica lineare linear thermal expansion coefficient linéaire de dilatation thermique Lineare Wärmeausdehnung	UNI EN ISO 10545-8	6 x 10 ⁻⁶
	resistenza alle macchie stain resistance résistance aux taches Fleckenfestigkeit	UNI EN ISO 10545-14	garantita guaranteed garantie garantiert
	resistenza alla scivolosità (Superficie Naturale) slip resistance (Matt surface) résistance au glissement (Surface naturelle) Trittsicherheit (Natur Oberflächen)	DIN 51130 D.M. N° 236 del 14.06.89 Metodo B.C.R. BS7976-2:2002 BSEN13036-4:2011	vedere singole serie see every series voir les séries une par une Siehe einzelne Serie valore $\mu > 0,40^{**}$ PTV > 36 ^{**}

* valore indicativo approx value donnée approximative Ungefähre Werte











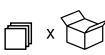

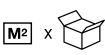
** Prova su superficie asciutta Test on a dry surface Essai sur surface sèche Test auf trockener Oberfläche

◆ Si rimanda all'elenco prodotti UPEC ufficiale, consultabile sul sito: Please see the official UPEC product list:

Veillez consulter la liste officielle produits UPEC: Sihe die offizielle UPEC-Produktliste auf der Website: <http://webapp.cstb.fr/upec-ceramique/>

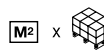
PESI, MISURE E CONTENUTO DEI COLLI WEIGHT, SIZE AND CONTENTS OF THE PACKING POIDS, DIMENSIONS, CONTENU DES COLIS VERPACKUNGSGRÖSSEN/GEWICHTE

ECOGRES

		 mm	 x 	 x 	 x 	 x 	 x 	 x 
cm 20x20	7 ⁷ / ₈ "x7 ⁷ / ₈ "	7,3	30	1,20	15,3	72	86,40	1.322
cm 30x60	11 ³ / ₄ "x23 ⁵ / ₈ "	8	6	1,08	18,0	48	51,84	933
cm 33x33	13"x13"	8,2	13	1,42	18,0	42	59,43	1.070
cm 33x33	13"x13"	8	13	1,42	18,0	42	59,64	1.074
cm 41,5x41,5	16 ³ / ₈ "x16 ³ / ₈ "	8	8	1,38	18,0	48	66,24	1.192
cm 60x60	23 ⁵ / ₈ "x23 ⁵ / ₈ "	9	4	1,44	20,0	30	43,20	881

BATTISCOPIA B.C. BULLNOSE PLINTHE À BORD ARRONDI STEH SOCKEL

		
cm 8x33	3 ¹ / ₄ "x13"	30
cm 8x41,5	3 ¹ / ₄ "x16 ³ / ₈ "	25
cm 9x60	3 ¹ / ₂ "x23 ⁵ / ₈ "	18

GRADINO STEP TREAD NEZ DE MARCHE STUFENPLATTE

		
cm 30x60	11 ³ / ₄ "x23 ⁵ / ₈ "	6
cm 33x33	13"x13"	13

CLASSIFICAZIONE DELLE PIASTRELLE DA PAVIMENTO IN BASE ALL'AMBIENTE DI DESTINAZIONE CLASSIFICATION OF THE FLOOR TILES ACCORDING TO THE FINAL DESTINATION CLASSIFICATION DES CARREAUX SELON L'ENTROIT DESTINE KLASSIFIZIERUNG DER BODENFLIESE NACH IHREM VERWENDUNGSZWECK

G1 Gruppo 1: Traffico leggero (bagni, camere da letto)

Group 1: Light wear (bathrooms, bedrooms)

Groupe 1: Trafic léger (salles de bains, chambres à coucher)

Gruppe 1: Leichte Beanspruchung (Bade und Schlafzimmer)

G2 Gruppo 2: Traffico-medio (appartamenti privati ad esclusione cucine)

Group 2: Medium wear (private apartments, kitchens excluded)

Groupe 2: Trafic moyen (appartements privés sauf cuisines)

Gruppe 2: Beanspruchung (Privatwohnungen außer Küchen)

G3 Gruppo 3: Traffico medio-forte (appartamenti, case private)

Group 3: Medium hard wear (flats and private houses)

Groupe 3: Trafic mi-fort (appartements et maisons)

Gruppe 3: Mittlere Beanspruchung (Wohnungen und Privathäuser)

G4 Gruppo 4: Traffico forte (ristoranti, uffici, edifici pubblici)

Group 4: Hard wear (restaurants, offices, public buildings)

Groupe 4: Trafic fort (restaurants, bureaux, édifices publics)

Gruppe 4: Starke Beanspruchung (Restaurant, Büros, öffentliche Gebäude)

Nel caso le piastrelle Ecogres siano destinate a rivestimento di pareti chiedere espressamente la fornitura dei jolly eventualmente necessari per il rivestimento degli spigoli.

In case Ecogres-Tiles have to be used as wall coverings, customers can expressly request the supply of mitred tiles for outcorners.

Si les carreaux Ecogres sont destinés à un revêtement mural, les clients peuvent demander exprèsment la fourniture de carreaux biseautés (jolly)

Für Wandelläge, können die Kunden eine ausdrückliche Lieferung von Jollys (fliesen mit Fase) für kanten eventuell verlangen.

STONALIZZAZIONE SHADE VARIATIONS

VARIATIONS D'OMBRE FARBTONVARIANTEN

La stonalizzazione indica il livello di variazione cromatica che sussiste, all'interno della stessa collezione fra una piastrella e l'altra.

The colour shading scale denotes the level of colour variation that exists between specific tiles in the same collection.

La « stonalisation » est le degré de variation chromatique qui existe entre un carreau et un autre de la même collection.

Die Schattierung zeigt den Grad der chromatischen Variation an, die innerhalb derselben Kollektion zwischen den einzelnen Fliesen besteht.

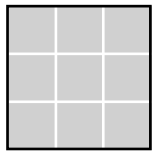

Uniforme
Uniform
Uniforme
Einheitlich

V1

L'aspetto delle piastrelle è uniforme. Differenze minime fra i prodotti appartenenti al medesimo lotto produttivo.

The appearance of the tiles is uniform. There are minimal differences in products belonging to the same production batch.

L'aspect des carreaux est uniforme. Les différences entre les produits appartenant à un même lot de production sont minimes.

Der optische Aspekt der Fliesen ist einheitlich. Die Unterschiede zwischen Produkten derselben Produktionscharge sind minimal.



Leggera
Subtle
Légère
Leicht

V2

L'aspetto delle piastrelle presenta leggere ma visibili differenze, che si tratti di segni grafici o sfumature/venature tipiche del materiale naturale di riferimento.

There are subtle yet visible differences in the appearance of the tile, whether these are clear markings or the typical shading/veining of the natural material in question.

L'aspect des carreaux présente des différences légères mais visibles, qu'il s'agisse de marques graphiques ou de nuances/veinures typiques du matériau naturel de référence.

Der optische Aspekt der Fliesen weist leichte aber sichtbare Unterschiede auf, wobei es sich um graphische Zeichnungen oder Schattierungen/Maserungen handelt, die für das natürliche Referenzmaterial typisch sind.

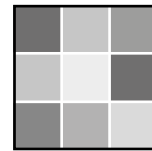

Media
Medium
Moyenne
Mittel

V3

L'aspetto delle piastrelle presenta variazioni di colore e/o struttura decisi. Questa variabilità cromatica è appositamente studiata in fase di progettazione della collezione per rendere il prodotto il più vicino possibile al materiale naturale di riferimento.

There are clear variations in the colour and/or structure of the tiles. This dynamic colour variation is meticulously planned during the collection design phase in order to make the product as similar as possible to the natural material in question.

L'aspect des carreaux présente des variations de couleur et/ou de structure marquées. Le caractère variable de la couleur est spécialement étudié lors de la conception de la collection pour rendre le produit le plus proche possible du matériau naturel de référence.

Der optische Aspekt der Fliesen weist deutliche Farb- und/oder Strukturunterschiede auf. Diese chromatische Variabilität wurde in der Designphase der Kollektion speziell entwickelt, um das Produkt seinem natürlichen Referenzmaterial so ähnlich wie möglich zu machen.



Accentuata
Accentuated
Forte
Akzentuiert

V4

L'aspetto delle piastrelle presenta variazioni importanti di colore e/o di struttura, rendendole, in alcuni casi, completamente diverse tra loro.

There are significant variations in the colour and/or structure of the tiles. In some cases, one tile can appear completely different to the next.

L'aspect des carreaux présente d'importantes variations de couleur et/ou de structure, ce qui les rend, dans certains cas, complètement différentes entre elles.

Der optische Aspekt der Fliesen weist bedeutende Farb- und/oder Strukturunterschiede auf, durch die sie sich in einigen Fällen vollständig voneinander abheben.

COMPLEMENTI IN ACCIAIO E ALLUMINIO
ACCESSORIES IN STEEL AND ALUMINIUM
COMPLÉMENTS EN ACIER ET EN ALUMINIUM
TECHNISCHE EIGENSCHAFTEN

terminale alluminio



cm 1x30 - $\frac{3}{8}$ "x $1\frac{3}{4}$ "

matita alluminio



cm 1,2x30 - $\frac{1}{2}$ "x $1\frac{3}{4}$ "

tozzetto alluminio



cm 1,5x1,5 - $\frac{5}{8}$ "x $\frac{5}{8}$ "

angolo terminale alluminio



cm 1x1 - $\frac{3}{8}$ "x $\frac{3}{8}$ "

matita acciaio



cm 0,3x60 - $\frac{1}{4}$ "x $2\frac{3}{8}$ "

bacchetta alluminio



cm 0,3x60 - $\frac{1}{4}$ "x $2\frac{3}{8}$ "

VOCI DI CAPITOLATO SPECIFICATIONS CAHIER DES CHARGES AUSSCHREIBUNGSTEXTE

GRANITOGRES

Piastrelle in gres porcellanato antiusura e antimacchia, ingelive, in prima scelta, pressate, *non smaltate e con effetti cromatici ottenuti solo con colorazione in massa*, pienamente vetrificate come da norme UNI EN ISO 14411-G - Gruppo B1a - con assorbimento d'acqua <0,1%, ottenute da miscele selezionate di argille, quarzi e feldspati cotte a temperatura di 1250°C tipo **Granitogres** di **Casalgrande Padana**, con superficie..., formato..., spessore..., colore..., serie..., scelte dalla direzione lavori, per i seguenti locali:

...

Supply of wear-resistant, stain-proof, frost proof, first grade, pressed, *unglazed porcelain stoneware tiles with chromatic effects obtained by full body colouring only*, fully vitrified in accordance with standards UNI EN ISO 14411-G - Group B1a - with <0.1% water absorption. Obtained by selected mixtures of clay, quartz and feldspars fired at 1250°C, type **Granitogres** by **Casalgrande Padana**, with surface textures..., formats..., thickness..., colour..., series..., chosen by the works management for the following places: ...

Fourniture de carreaux de grès cérame résistant à l'usure, aux tâches et au gel, en premier choix, pressés, *non émaillés et à effets chromatiques obtenus seulement par coloration dans la masse*, pleinement vitrifiés conformément aux normes UNI EN ISO 14411-G - Groupe B1a - absorption d'eau <0,1%, obtenus à partir de mélanges sélectionnés d'argiles, quartz et feldspaths cuits à des températures de 1250°C type **Granitogres** de **Casalgrande Padana**, à surface..., format..., épaisseur..., couleur..., série..., choisis par la direction des travaux pour les locaux suivants : ...

Lieferung vor Feinsteinzeugplatten, verschleißfest und fleckenfest, frostsicher, in erster Wahl, gepresst, *unglasiert mit chromatischen Effekten, die sich nur durch die Einfärbung der gesamten Masse erhalten lassen*, voll durchgesintert nach den Normen UNI EN ISO 14411-G - Gruppe B1a - mit Wasseraufnahme <0,1%, erhalten aus ausgesuchten Mischungen von Tonerden, Quarzen und Feldspaten, bei einer Temperatur von 1250°C gebrannt, Typ **Granitogres** von **Casalgrande Padana**, mit Oberflächen..., Format..., Stärke..., Farbe..., Serie..., von der Bauleitung für die folgenden Räume gewählt: ...

PIETRE NATIVE

Piastrelle in gres porcellanato antiusura e antimacchia, ingelive, in prima scelta, pressate, colorate in massa, pienamente vetrificate come da norme UNI EN ISO 14411-G - Gruppo B1a - con assorbimento d'acqua <0,1%, ottenute da miscele selezionate di argille, quarzi e feldspati cotte a temperatura di 1250°C tipo **Pietre Native** di **Casalgrande Padana**, con superficie..., formato..., spessore..., colore..., serie..., scelte dalla direzione lavori, per i seguenti locali: ...

Supply of wear-resistant, stain proof, frost proof, first grade, pressed, full body coloured porcelain stoneware tiles, fully vitrified in accordance with standards UNI EN ISO 14411-G - Group B1a - with <0.1% water absorption. Obtained by selected mixtures of clay, quartz and feldspars fired at 1250°C, type **Pietre Native** by **Casalgrande Padana**, with surface textures..., formats..., thickness..., colour..., series..., chosen by the works management for the following places: ...

Fourniture de carreaux de grès cérame résistant à l'usure, aux tâches et au gel, en premier choix, pressés, colorés dans la masse, pleinement vitrifiés conformément aux normes UNI EN ISO 14411-G - Groupe B1a - absorption d'eau <0,1%, obtenus à partir de mélanges sélectionnés d'argiles, quartz et feldspaths cuits à des températures de 1250°C type **Pietre Native** de **Casalgrande Padana**, à surface..., format..., épaisseur..., couleur..., série..., choisis par la direction des travaux pour les locaux suivants : ...

Lieferung vor Feinsteinzeugplatten, verschleißfest und fleckenfest, frostsicher, in erster Wahl, gepresst, in der Masse durchgefärbt, voll durchgesintert nach den Normen UNI EN ISO 14411-G - Gruppe B1a - mit Wasseraufnahme <0,1%, erhalten aus ausgesuchten Mischungen von Tonerden, Quarzen und Feldspaten, bei einer Temperatur von 1250°C gebrannt, Typ **Pietre Native** von **Casalgrande Padana**, mit Oberflächen..., Format..., Stärke..., Farbe..., Serie..., von der Bauleitung für die folgenden Räume gewählt: ...

GRANITOKER

Piastrelle in gres porcellanato, antimacchia e ingelive, in prima scelta colorate in massa, pienamente vetrificate, come da norme UNI EN ISO 14411-G - Gruppo B1a - con assorbimento d'acqua < 0,1%, ottenute da miscele selezionate di argille, quarzi e feldspati cotte a temperatura di 1250°C, tipo **Granitoker** di **Casalgrande Padana** con superficie..., formato..., spessore..., colore..., serie..., scelte dalla direzione lavori, per i seguenti locali: ...

Supply of stain proof, frost proof, first grade, body coloured porcelain stoneware tiles, fully vitrified, in accordance with standards UNI EN ISO 14411-G - Group B1a - with < 0.1% water absorption. Obtained by selected mixtures of clay, quartz and feldspars fired at 1250°C, type **Granitoker** by **Casalgrande Padana**, with surface textures..., formats..., thickness..., colour..., series..., chosen by the works management for the following places: ...

Fourniture de carreaux de grès cérame résistant aux tâches et au gel, en premier choix, colorés dans la masse, pleinement vitrifiés conformément aux normes UNI EN ISO 14411-G - Groupe B1a - absorption d'eau < 0,1%, obtenus à partir de mélanges sélectionnés d'argiles, quartz et feldspaths cuits à des températures de 1250°C type **Granitoker** de **Casalgrande Padana**, à surface..., format..., épaisseur..., couleur..., série..., choisis par la direction des travaux pour les locaux suivants : ...

Lieferung vor Feinsteinzeugplatten, fleckenfest und frostsicher, in erster Wahl, in der Masse durchgefärbt, voll durchgesintert, nach den Normen UNI EN ISO 14411-G - Gruppe B1a - mit Wasseraufnahme < 0,1%, erhalten aus ausgesuchten Mischungen von Tonerden, Quarzen und Feldspaten, bei einer Temperatur von 1250°C gebrannt, Typ **Granitoker** von **Casalgrande Padana** mit Oberflächen..., Format..., Stärke..., Farbe..., Serie..., von der Bauleitung für die folgenden Räume gewählt: ...

GRESPLUS

Piastrelle in gres porcellanato, antimacchia e ingelive, in prima scelta smaltate, pienamente vetrificate, come da norme UNI EN 14411 ISO 13006 - Gruppo BI a - con assorbimento d'acqua 0,1%, ottenute da miscele selezionate di argille, quarzi e feldspati cotte a temperatura di 1250°C, tipo **Gresplus** di **Casalgrande Padana** con superficie ..., formato ..., spessore ..., colore ..., serie ..., scelte dalla direzione lavori, per i seguenti locali: ...

Supply of stain proof, frost proof, first grade, glazed, fully vitrified porcelain stoneware tiles, in accordance with standards UNI EN 14411-G ISO 13006 - Group BIa - with 0.1% water absorption. Obtained by selected mixtures of clay, quartz and feldspars fired at 1250°C, type **Gresplus** by **Casalgrande Padana**, with surface textures ..., formats ..., thickness ..., colour ..., series ..., chosen by the works management for the following places: ...

Fourniture de carreaux de grès cérame résistant aux tâches et au gel, en premier choix, émaillés, pleinement vitrifiés conformément aux normes UNI EN 14411-G ISO 13006 - Groupe BI a - absorption d'eau 0,1%, obtenus à partir de mélanges sélectionnés d'argiles, quartz et feldspaths cuits à des températures de 1250°C type **Gresplus** de **Casalgrande Padana**, à surface ..., format ..., épaisseur ..., couleur ..., série ..., choisis par la direction des travaux pour les locaux suivants : ...

Lieferung vor Feinsteinzeugplatten, fleckenfest und frostsicher, in erster Wahl, glasiert, voll durchgesintert, nach den Normen UNI EN 14411-G ISO 13006 - Gruppe BIa - mit Wasseraufnahme 0,1%, erhalten aus ausgesuchten Mischungen von Tonerden, Quarzen und Feldspaten, bei einer Temperatur von 1250°C gebrannt, Typ **Gresplus** von **Casalgrande Padana** mit Oberflächen ..., Format ..., Stärke ..., Farbe ..., Serie ..., von der Bauleitung für die folgenden Räume gewählt: ...

ECOGRES

Piastrelle in monocottura in pasta bianca, in prima scelta, pressate, smaltate, tipo **Ecogres** di **Casalgrande Padana**, come da norme UNI EN 14411 ISO 13006 - Gruppo BIb GL con superficie ..., formato ..., spessore ..., colore ..., serie ..., scelte dalla direzione lavori, per i seguenti locali: ...

Casalgrande Padana's Ecogres first-choice single-fired, white body, pressed enamelled tiles comply with EN 14411 and ISO 13006 - Group BIb GL. Surface: ...; format: ...; thickness ...; colour: ...; series: ..., chosen by Construction Supervision for the following rooms: ...

Carreaux en monocuisson à pâte blanche, de premier choix, pressés, émaillés, type **Ecogres** de **Casalgrande Padana**, conformément aux normes UNI EN 14411 ISO 13006 - Groupe BIb GL avec surface ..., format ..., épaisseur ..., couleur ..., série ..., choisis par le maître d'ouvrage, pour les locaux suivants : ...

Einbrandfliese weißscherbig, erste Wahl, gepresst, lackiert, Typ **Ecogres** von **Casalgrande Padana**, konform mit DIN EN 14411 / ISO 13006 - Gruppe BIb GL Oberfläche: ...; Format: ...; Stärke: ...; Farbe: ...; Serie: ...; ausgewählt von der Bauleitung für folgende Räume: ...

POSA E MANUTENZIONE

POSA IN OPERA

La riuscita di un pavimento è dovuta non solo alla qualità delle piastrelle, ma a tutto un insieme di elementi (sottofondo, strato legante, giunti di dilatazione, ecc.) che costituiscono un vero e proprio sistema. Ecco perché le operazioni di posa sono da considerarsi importanti tanto quanto la scelta delle piastrelle. È comunque compito del progettista stabilire, in funzione della struttura e della destinazione d'uso del piano di calpestio, il corretto modo di applicazione delle piastrelle e il tipo di piastrella da utilizzare. Le piastrelle **Casalgrande Padana** non si differenziano, per quanto riguarda le operazioni di posa, da una qualsiasi altra ceramica e si può quindi seguire sia il sistema tradizionale con malta cementizia, che quello con collanti o adesivi.

È consigliabile ricorrere ad un sistema di posa con adesivo, da prescriversi in funzione dell'ambiente di destinazione, della tipologia e delle caratteristiche del supporto di posa, del formato considerato e dei carichi statici/dinamici agenti sulla piastrellatura ceramica. È inoltre necessario verificare, prima di procedere alla posa, che il supporto possieda idonee caratteristiche per l'incollaggio della ceramica, quali: stabilità e regolarità dimensionale, rigidità, assenza di fessurazioni, pulizia e integrità superficiale, assenza di umidità in eccesso e/o di agenti contaminanti. Prima di iniziare le operazioni di posa di una qualsiasi superficie si raccomanda di accertarsi che la partita di grès sia adeguata e sufficiente per quantità, tono e calibro, a quella necessaria. Si dovranno poi seguire tutte le norme e le precauzioni che sono alla base di una corretta esecuzione del lavoro (preparazione del sottofondo, composizione della malta o dei collanti, tempi di maturazione, posizionamento dei giunti di dilatazione, battitura, ecc.).

Se per ambienti di grandi dimensioni è assolutamente necessario posizionare i giunti con regolarità, per piccoli ambienti è sufficiente lasciare un leggero stacco fra piastrellato e muri perimetrali. Sarà poi il battiscopa a coprire lo stacco dando un aspetto di finitura. Evitare il transito sul pavimento per almeno 2/3 giorni dopo la posa.

In caso di necessità di transito si dovrà predisporre un tavolato appoggiato sul pavimento.

Successivamente alla posa si raccomanda di proteggere adeguatamente il pavimento sino al termine del cantiere in modo tale da evitare danni causati da sostanze abrasive o da altri agenti dannosi.

Le piastrelle **Casalgrande Padana** pur essendo materiale molto resistente, possono essere sagomate o perforate per l'installazione di impianti tecnico sanitari, utilizzando una attrezzatura adeguata.

Un pavimento o rivestimento murale **Casalgrande Padana** Padana sia nella versione naturale che lappata, lucida, o levigata, è sinonimo di bellezza, durata e resistenza nel tempo.

La sua manutenzione non richiede particolari cure se non l'attenersi alle seguenti norme di pulizia.

PRIMA PULIZIA

Ha lo scopo di eliminare ogni traccia di cemento o stucco conseguente alla chiusura dei giunti. Si esegue normalmente una sola volta prima dell'utilizzo del pavimento/rivestimento e deve essere obbligatoriamente eseguita dopo la posa in opera e prima dell'uso del pavimento/rivestimento.

Procedere nel modo seguente:

1. Spazzare il pavimento/rivestimento raccogliendo lo sporco grossolano.
2. Inumidire con acqua la superficie affinché le fughe vengano impregnate e pertanto protette dall'azione corrosiva del detergente a componente acida (decalcificante).
3. Stendere il detergente (vedi nota A) nella concentrazione (rapporto di miscelazione con l'acqua) indicata dal produttore, applicandolo con una spazzola manuale o motorizzata.

Per la serie Metallica utilizzare detergenti molto diluiti (diluizione 1-5, 1 parte di acido e 5 parti di acqua) e assicurarsi in particolare un abbondante risciacquo seguito da asciugatura completa del pavimento. Evitare che il detergente acido venga a contatto con componenti di

acciaio, alluminio e marmo naturale adiacenti al pavimento/rivestimento.

- 4) Durante il tempo d'azione, che deve essere stabilito in relazione allo stato del pavimento, strofinare lo sporco più ostinato (e raschiare eventuali residui di malta, stucco, etc...).
- 5) Sciacquare il pavimento/rivestimento con acqua e raccogliere subito l'acqua sporca (manualmente o con un apparecchio lavasciuga).

Se la prima pulizia viene eseguita dopo che il pavimento/rivestimento è già stato usato, sarà bene, prima dell'applicazione del detergente a base acida, togliere con appositi detersivi alcalini (sgrassanti) eventuali presenze di sostanze grasse o simili (vedi Pulizia ordinaria).

L'operazione di prima pulizia, se ritenuto necessario, può essere ripetuta.

SUPERFICIE LEVIGATA, LUCIDA E LAPPATA

Una leggera diminuzione della lucentezza dei pavimenti levigati, a seguito del primo lavaggio acido del pavimento, deve essere considerata normale, perché dovuta alla eliminazione dei residui degli abrasivi utilizzati nella lavorazione della superficie.

A. Alcuni detergenti consigliati per eliminare i residui di stucco:

Fughe realizzate con stucco cementizio detergenti a componente acida (decalcificanti)

Deterprimo plus (Casalgrande Padana), Deterdek (Fila), Keranet (Mapei), Deltaplus (Kerakoll), Solvacid (Geal) o simili (seguire istruzioni del produttore del detergente).

Fughe realizzate con stucco epossidico detergenti a componente alcalina

Fuga-Soap Eco (Kerakoll), Kerapoxy Cleaner (Mapei), Tile Cleaner (Faber), CR10 (Fila), Lithofin Resin-Ex (Lithofin), Eposolv (Geal) o simili (seguire istruzioni del produttore del detergente).

PULIZIA ORDINARIA

Per la pulizia di tutti i giorni è sufficiente lavare il pavimento/rivestimento con acqua e aggiunta di normali prodotti detergenti adatti a pulire superfici ceramiche (per i rivestimenti utilizzare detergenti in gel).

Assicurarsi che i detergenti non contengano sostanze cerosi; la superficie dei prodotti installation operations, **Casalgrande Padana**, essendo praticamente inassorbente, non richiede l'applicazione di cere e/o prodotti silconici di protezione che, al contrario, non debbono mai essere usati (possono creare un film superficiale che andrebbe a modificare le caratteristiche naturali del grès porcellanato). In presenza di macchie persistenti e difficili da togliere con la pulizia ordinaria, intervenire con impiego di detergenti più concentrati lasciando agire gli stessi per un adeguato intervallo di tempo e, successivamente, strofinare con adeguata intensità, fino a ricondurre le piastrelle all'aspetto originario. Al riguardo è opportuno segnalare che il grès è resistente a qualsiasi sostanza chimica, **eccezion fatta per l'acido fluoridrico che attacca tutti i prodotti ceramici e che, quindi, non deve mai essere utilizzato.**

Per la pulizia di pavimenti in aree pubbliche si consiglia di intervenire dopo la chiusura dei locali, affinché il pavimento alla riapertura sia asciutto; in alternativa isolare il pavimento pulito fino alla sua completa asciugatura.

Per i locali di maggiore estensione è opportuno disporre di macchine lavasciuga, per assicurare una perfetta pulizia e igienicità.

Il pavimento deve essere considerato pulito quando riacquista il suo aspetto originario!

INSTALLATION AND MAINTENANCE

INSTALLATION

The successful installation of floors depends not only on the quality of tiles but on a combination of factors (bedding, binding layer, expansion joints, etc.) that constitute a real system.

That is why installation operations are to be considered as important as the choice of tiles. However, based on the structure and purpose of the flooring surface, the designer is still responsible for defining the correct procedure to lay the tiles and selecting the ones to be employed. When it comes to installation operations, **Casalgrande Padana** do not differ from any other type of ceramic: either the traditional procedure envisaging cement mortar or the procedure envisaging glues and adhesives may be resorted to. We recommend using an installation system with an adhesive according to the intended use of the room, type and characteristics of the substrate, and size in consideration of the static/dynamic loads on the ceramic tiles.

You must first ensure that the substrate has suitable characteristics for glueing ceramics, such as stability and dimensional regularity, rigidity, absence of cracks, clean and intact surface, and absence of excess moist and/or contaminants.

Before starting the installation operations of any surface, we recommend you make sure that the stoneware batch is adequate and sufficient in terms of quantity, tone and calibration.

Moreover, all necessary norms and precautions need to be implemented for the correct completion of the work (bedding preparation, composition of mortar or adhesives, maturing period, positioning expansion joints, ramming, etc.).

If in case of large environments joints must be positioned at regular intervals, in small environments a small gap between the tiles and perimeter walls is sufficient: the skirting board will cover the gap and provide the finishing effect.

Avoid walking on the floor for at least 2/3 days after installation. If walking on the floor is necessary, lay wooden planks on the surface.

After laying, it is recommended to adequately protect the floor until finished in order to avoid damage caused by abrasive substances or other harmful agents.

Even though **Casalgrande Padana** tiles are very resilient material, they can be shaped or perforated to install technical and sanitary systems, using appropriate equipment.

FIRST CLEAN

A **Casalgrande Padana** flooring or wall covering, whether natural, lapped, lucida or polished, is synonym with beauty, strength and a long life. These surfaces are low maintenance and only need be cleaned as described below.

The purpose of first-time cleaning is to remove any trace of cement or plaster used to close the joints.

The flooring/wall covering is normally cleaned once before use. This must be done after installation and before use.

Proceed as follows:

1. Sweep the floor/covering to remove the coarser dirt.
2. water so as to soak the joints, thereby protecting them from the corrosive action of the acid detergent (descaling product).
3. Apply the detergent (see note A) in the concentration (water mixing ratio) indicated by the manufacturer using a manual or motorised brush. With regards to the Metallica series, use very diluted detergents (1-5 dilution i.e., 1 part acid to 5 parts water), rinse thoroughly, and leave the floor to dry completely. Avoid any contact between the acid detergent and the steel, aluminium, and natural marble components near the flooring/wall covering.
4. Leave it as long as needed depending on the condition of the floor, then rub any stubborn dirt away (such as mortar, plaster, etc. ...).
5. Rinse the flooring/covering with water and mop up the dirty water immediately (manually or with a washer/drier).

If the flooring/wall covering is cleaned for the first time after being used, it is important to use appropriate alkaline detergents (degreasing agents) before applying the acid detergent to remove any greasy or similar substance (see Routine Cleaning).

If necessary, you can repeat the first-time cleaning operations described above.

POLISHED, LUCIDA AND LAPPED SURFACES

A slight loss of shine after the first acid wash must be considered normal, as it is due to the removal of the abrasive residues used for processing the surface.

A. Here are a few detergents recommended for removing plaster residues:

Cement plaster joints – acid detergents (descaling products)

Deterprimo Plus (Casalgrande Padana), Deterdek (Fila), Keranet (Mapei), Deltaplus (Kerakoll), Solvacid (Geal) or similar detergents (follow the manufacturer's instructions).

Epoxy plaster joints – alkaline detergents

Fuga-Soap Eco (Kerakoll), Kerapoxy Cleaner (Mapei), Tile Cleaner (Faber), CR10 (Fila), Lithofin Resin-Ex (Lithofin), Eposolv (Geal) or similar detergents (follow the manufacturer's instructions).

ROUTINE CLEANING

For everyday cleaning, all you have to do is wash the flooring/wall covering with water and normal neutral detergents suitable for ceramic surfaces (for wall coverings use a neutral gel detergent gel).

Make sure that the detergents do not contain waxy substances.

The surface of installation operations, **Casalgrande Padana** products are practically non-absorbent; therefore, the use of wax and/or silicone cleaners is not required. These should never be used, as they create a superficial film that changes the natural characteristics of porcelain stoneware. Should there be any stubborn stain that cannot be removed by routine cleaning, use a more concentrated detergent and leave it on for long enough, then rub harder until the tiles are back to their original condition. Note that porcelain stoneware is resistant to any chemical, **except hydrofluoric acid, which eats into any ceramic, so it must never be used.**

Floors of public areas should be cleaned when the place is closed, so the floor will be dry when it reopens; otherwise, fence off the cleaned floor until perfectly dry.

For larger places, use a washer/drier to ensure perfect cleanliness and hygiene.

The flooring is to be considered clean when it returns to its original appearance!

POSE ET ENTRETIEN

POSE

Un bon sol dépend non seulement de la qualité des carreaux, mais aussi de toute une série d'éléments qui constituent un seul tout (couche de fond, couche d'un agent liant, joints de dilatation, etc.). C'est pourquoi les opérations de pose sont tout aussi importantes que le choix du carrelage. Il appartient à l'architecte d'établir le type de carrelage à utiliser en fonction du lieu et de l'utilisation du sol ainsi que la meilleure méthode de pose des carreaux. En ce qui concerne les opérations de pose, les séries **Casalgrande Padana** ne sont pas différentes des autres carreaux céramiques et il est donc possible de suivre la méthode traditionnelle en utilisant du mortier de ciment ou d'utiliser des colles ou autres produits adhésifs. Il est conseillé de recourir à un système de pose avec de l'adhésif, à adopter en fonction de l'environnement de destination, de la typologie et des caractéristiques du support de pose, du format envisagé et des charges statiques/dynamiques appliquées sur le carrelage en céramique. Avant de procéder à la pose, il est également nécessaire de s'assurer que le support possède les caractéristiques appropriées pour le collage de la céramique. Ces caractéristiques sont les suivantes : stabilité et régularité dimensionnelle, rigidité, absence de fissures, nettoyage et intégrité de la surface, absence d'excès d'humidité et/ou d'agents de contamination. Avant de commencer les opérations de pose, il est recommandé de vérifier que les lots de carreaux en grès correspondent bien à la quantité, à la couleur et au calibre nécessaires.

Il faut ensuite respecter toutes les normes et les précautions qui sont à la base de la bonne exécution des travaux (préparation de la couche de fond, composition du mortier ou des colles, positionnement des joints de dilatation, nivellement à l'aide du maillet, temps de séchage, etc.).

Pour les grandes surfaces, il est absolument nécessaire de positionner les joints avec la plus grande régularité, tandis que pour les petites surfaces, il suffira de laisser un léger écart entre le carrelage et les murs périmétraux. Ce seront ensuite les plinthes qui couvriront l'écart pour donner l'aspect de finition. Après la pose, éviter de marcher sur le sol pendant au moins 2 ou 3 jours. Si le passage s'avère nécessaire, il faudra poser des planches sur le sol.

Après la pose, il est recommandé de protéger le sol de manière adéquate jusqu'à la fin des travaux afin d'éviter tout dommage pouvant être causé par des substances abrasives ou par d'autres agents nocifs.

Même si les carreaux des séries **Casalgrande Padana** sont extrêmement résistants, ils peuvent être façonnés et perforés pour installer les équipements technico-sanitaires en utilisant les outils appropriés.

Les revêtements de sol et de mur de installation operations, **Casalgrande Padana**, qu'ils soient en version naturelle, poncée, brillante ou polie, sont synonymes de beauté, de solidité et de durabilité.

Ils n'exigent aucune opération d'entretien particulière, il suffit de suivre les conseils d'entretien suivants :

PREMIER NETTOYAGE

Son but est d'éliminer toute trace de ciment ou de mortier-colle après le jointolement. Cette opération est généralement effectuée une seule fois avant d'utiliser le revêtement sol/mur, et il faut obligatoirement l'effectuer après la pose et avant toute utilisation du revêtement sol/mur. Procéder de la manière suivante :

- 1., Balayer/épousseter le revêtement sol/mur en éliminant toutes traces d'impuretés.
2. Humidifier la surface avec de l'eau de manière à bien imprégner les joints afin qu'ils soient ainsi bien protégés de l'action corrosive du nettoyant acide (décalcifiant).
3. Respecter la concentration (quantité à diluer dans l'eau) indiquée par le fabricant pour l'utilisation du produit nettoyant, et appliquer le produit (voir note A) à l'aide d'une brosse manuelle ou motorisée. Pour la série Metallica, utiliser des nettoyants acides après les avoir bien dilués dans l'eau (rapport 1-5, 1 part d'acide et 5 parts

d'eau), puis veiller à bien rincer et à essuyer complètement le sol.

Veillez à ce que le nettoyant acide n'entre pas en contact d'éléments en acier et en aluminium, ou d'éléments en marbre naturel placés à proximité du revêtement sol/mur.

4. Pendant le temps d'action du produit, à établir en fonction de l'état du

sol, frotter les taches les plus persistantes (et racler d'éventuels résidus de mortier, de mortier-colle, etc.).

5. Rincer le revêtement sol/mur avec de l'eau, puis éliminer immédiatement l'eau sale (à la main ou avec un appareil de nettoyage à aspiration d'eau).

Si le premier nettoyage est effectué après avoir utilisé le revêtement sol/mur, avant d'appliquer le nettoyant acide, il est conseillé d'éliminer toute éventuelle trace de substance grasse ou similaire en utilisant les nettoyants alcalins (dégraissants) prévus à cet effet (voir Nettoyage ordinaire). S'il y a lieu, répéter cette première opération de nettoyage.

SURFACES POLIES, BRILLANTES ET PONCÉES

Après le premier lavage avec le nettoyant acide, une légère diminution de la brillance des sols polis doit être considérée normale, étant due à l'élimination des résidus abrasifs utilisés lors du traitement de surface effectué en usine.

- A. Voici certains nettoyants conseillés pour éliminer les résidus de mortier-colle :

Jointés réalisés en mortier-ciment nettoyants acides (décalcifiants)

Deterprimo plus (Casalgrande Padana), Deterdek (Fila), Keranet (Mapei), Deltaplus (Kerakoll), Solvacid (Geal) ou produits similaires (suivre les instructions du fabricant du produit nettoyant).

Jointés réalisés en mortier-époxy – nettoyants alcalins

Fuga-Soap Eco (Kerakoll), Kerapoxy Cleaner (Mapei), Tile Cleaner (Faber), CR10 (Fila), Lithofin Resin-Ex (Lithofin), Eposolv (Geal) ou produits similaires (suivre les instructions du fabricant du produit nettoyant).

NETTOYAGE ORDINAIRE

Pour le nettoyage quotidien, il suffit de laver le revêtement sol/mur avec de l'eau en y diluant des produits nettoyants adaptés aux surfaces en céramique (pour les murs, utiliser des produits nettoyants sous forme de gel). S'assurer que les produits nettoyants ne contiennent pas de substances à base de cire ; la surface des produits installation operations, **Casalgrande Padana** étant pratiquement non absorbante, il n'y a aucun besoin de passer ni cire ni autre produit similaire de protection à base de silicone ; bien au contraire, ces produits ne doivent jamais être utilisés (ils pourraient créer un film superficiel susceptible de modifier les caractéristiques naturelles du grès cérame).

Néanmoins, en cas de taches persistantes et difficiles à éliminer par un nettoyage ordinaire, utiliser un produit nettoyant plus puissant en le laissant agir pendant un temps adéquat, puis frotter énergiquement jusqu'à ce que le carrelage retrouve son aspect d'origine. Il est intéressant de signaler que le grès résiste aux substances chimiques, **à l'exception de l'acide fluorhydrique qui attaque tous les produits céramiques et qui ne doit donc jamais être utilisé.**

Pour le nettoyage de lieux publics, il est conseillé d'effectuer l'entretien après la fermeture des locaux, afin que le sol soit bien sec avant la réouverture. En alternative, isoler le sol nettoyé jusqu'à ce qu'il soit complètement sec.

Pour le nettoyage des sols sur de grandes surfaces, il convient d'utiliser des autolaveuses, pour garantir une hygiène et un nettoyage parfaits.

Le sol doit être considéré comme propre lorsqu'il retrouve son aspect d'origine !

VERLEGUNG UND PFLEGE

VERLEGUNG

Das gute Gelingen eines Bodenbelags hängt nicht nur von der Qualität der Fliesen ab, sondern von einer ganzen Reihe an Elementen (Untergrund, Bindschicht, Dehnungsfugen, usw.), die ein Gesamtsystem bilden. Deshalb sind die Verlegungsarbeiten genauso wichtig, wie die Wahl der Fliesen. Der Planer hat die Aufgabe, je nach Struktur und Bestimmungszweck der Bodenfläche die korrekte Fliesen-Verlegungsmethode und die Art der einzusetzenden Fliesen zu bestimmen. **Casalgrande Padana** unterscheiden sich in Bezug auf die Verlegungsarbeiten nicht von anderen Keramikprodukten, so dass die Verlegung sowohl auf traditionelle Art mit Zementmörtel als auch mit Leimen oder Klebstoffen erfolgen kann. Es wird empfohlen, ein Verlegesystem mit Klebstoff zu verwenden, das der vorgesehenen Umgebung, der Art und den Eigenschaften des Untergrunds, am gewöhnlichsten Format und der auf die Fliesen einwirkende statischen bzw. dynamische Kraft vorgeschrieben wird. Vor der Verlegung ist eine Prüfung erforderlich, der Untergrund die entsprechenden Eigenschaften für eine Verklebung von Keramikfliesen besitzt. Entscheidend hierfür sind ein gleichbleibendes, regelmäßiges Flächenmaß, Steifigkeit, keine Risse, saubere Oberfläche frei von Fehlstellen, keine verbleibende Feuchtigkeit und/oder Schadstoffverunreinigungen.

Vor Beginn der Verlegung auf jeglichen Oberflächen ist unbedingt sicher zu stellen, dass das Steinzeug geeignet ist und in der notwendigen Menge und im gewünschten Farbton und Werkmaß zur Verfügung steht. Es müssen zudem alle Vorschriften und Vorkehrungen beachtet werden, die einer korrekten Ausführung der Arbeiten zu Grunde liegen (Vorbereitung des Untergrundes, Zubereitung des Mörtels oder der Kleber, Abbindezeiten, Position der Dehnungsfugen, Anklopfen, usw.). In großflächigen Bereichen sind unbedingt regelmäßig Dehnungsfugen einzuplanen, während es in kleinen Bereichen genügt, ein wenig Abstand zwischen Fliesenfläche und Randmauern zu lassen. Mit der Sockelleiste wird dieser Abstand dann abgedeckt, um den Boden fertig zu stellen. Nach dem Verlegen darf der Boden mindestens 2-3 Tage nicht begangen werden. Falls ein Begehen notwendig sein sollte, müssen zuvor Planken auf den Boden gelegt werden. Nach der Verlegung sollte der Bodenbelag bis zum Abschluss der Bauarbeiten angemessen geschützt werden, um Beschädigungen durch abrasive Substanzen oder andere schädliche Agentien zu vermeiden. Obwohl es sich bei den Platten von **Casalgrande Padana** um hochresistente Materialien handelt, lassen sie sich für die Installation von technisch-sanitären Anlagen unter Verwendung geeigneter Geräte zuschneiden oder bohren.

Ein Fußboden oder eine Wandverkleidung von **Casalgrande Padana** ist sowohl in der natürlichen wie auch anpolierten, polierten oder geschliffenen Ausführung Ausdruck von Schönheit, Widerstandsfähigkeit und Langlebigkeit. Die Instandhaltung solcher Beläge verlangt keine besonderen Pflegemaßnahmen, sondern lediglich die Beachtung der folgenden Reinigungsverfahren.

ERSTREINIGUNG

Sie dient dazu, nach der Verfugung jegliche Spur von Zement oder Fugenmörtel zu entfernen.

Normalerweise wird sie nur einmal vor der Verwendung des Fußbodens bzw. der Wandverkleidung durchgeführt und sollte nach der Verlegung und vor der Nutzung vorgenommen werden.

Gehen Sie dazu folgendermaßen vor:

1. Den Fußboden/die Verkleidung fegen und den groben Schmutz entfernen.
2. Die Oberfläche mit Wasser befeuchten, um die Fugen zu imprägnieren und somit vor der ätzenden Wirkung des säurehaltigen Reinigungsmittels (Kalklöser) zu schützen.
3. Das Reinigungsprodukt (*siehe Anmerkung A*) in der vom Hersteller vorgegebenen Konzentration (Mischverhältnis mit Wasser) mit einer Handbürste oder einer motorbetriebenen Bürste auftragen.

Für die Metallica-Serie unbedingt stark verdünnte Reinigungsmittel (Mischverhältnis 1:5, 1 Teil Säure und 5 Teile Wasser) verwenden; dabei muss ganz besonders auf ein ausreichendes Nachspülen und eine vollständige Trocknung des Bodens geachtet werden.

Den Kontakt des säurehaltigen Reinigungsmittels mit etwaigen Komponenten aus Stahl, Aluminium und Naturmarmor, die am Fußboden/an der Wandverkleidung angrenzen, vermeiden.

4. Während der Wirkzeit, die je nach Zustand des Fußbodens festzulegen ist, den hartnäckigsten Schmutz abreiben (und etwaige Mörtel- und Kittrückstände usw. abkratzen).
5. Den Fußboden/die Wandverkleidung mit Wasser abspülen und das Schmutzwasser sofort aufnehmen (von Hand oder mit einer Bodenreinigungsmaschine).

Wenn die Erstreinigung erst nach der Benutzung des Fußbodens/der Wandverkleidung erfolgt, müssen vor der Anwendung des säurehaltigen Reinigungsmittels etwaige Fette oder ähnliche Stoffe mit geeigneten Alkalireinigern (Fettlösern) entfernt werden (siehe Normale Reinigung). Falls erforderlich, kann die Erstreinigung wiederholt werden.

GESCHLIFFENE, POLIERTE UND ANPOLIERTE OBERFLÄCHEN

Ein leichter Glanzverlust bei geschliffenen Oberflächen infolge der ersten säurehaltigen Wäsche des Fußbodens ist als normal zu betrachten, da er auf die Entfernung der Rückstände der für die Oberflächenbearbeitung verwendeten Schleifmittel zurückzuführen ist.

- A. Einige empfohlene Reinigungsmittel zur Entfernung von Mörtelresten:

Verfugung mit Zementfugenmörtel

säurehaltige Reinigungsmittel (Kalklöser)

Deterprimo plus (Casalgrande Padana), Deterdek (Fila), Keranet (Mapei), Deltaplus (Kerakoll), Solvacid (Geal) oder ähnliche Mittel (die Angaben des Reinigungsmittelherstellers beachten).

Verfugung mit Epoxidfugenmörtel

alkalische Reinigungsmittel

Fuga-Soap Eco (Kerakoll), Kerapoxy Cleaner (Mapei), Tile Cleaner (Faber), CR10 (Fila), Lithofin Resin-Ex (Lithofin), Eposolv (Geal) oder ähnliche Mittel (die Angaben des Reinigungsmittelherstellers beachten).

NORMALE REINIGUNG

Für die Alltagsreinigung genügt es, den Fußboden/die Wandverkleidung mit Wasser und normalen Reinigungsmitteln für Keramikflächen zu reinigen (für Wandverkleidungen Gels verwenden). Da die Oberflächen der Produkte von installation operations, **Casalgrande Padana** praktisch nicht aufnahmefähig sind, müssen für ihren Schutz keine Wachse und/oder silikonhaltige Produkte aufgetragen werden. Ganz im Gegenteil sollten diese niemals verwendet werden (sie können einen Oberflächenfilm bilden, der die natürlichen Eigenschaften des Feinsteinzeugs verändert). Bei beständigen und schwer entfernbaren Flecken, die sich nicht mit einer normalen Reinigung beseitigen lassen, können konzentriertere Reinigungsmittel verwendet werden; diese sollte man für eine angemessene Zeit einwirken lassen und dann angemessen kräftig abreiben, bis die Platten wieder ihr ursprüngliches Aussehen zurückerhalten. Wir weisen darauf hin, dass Steinzeug gegen alle chemischen Mittel beständig ist, mit Ausnahme von Fluorwasserstoffsäure, **die alle Keramikprodukte angreift und daher nicht verwendet werden darf**. In öffentlichen Bereichen sollte die Reinigung nach der Schließzeit vorgenommen werden, damit der Boden bei der Wiedereröffnung trocken ist; anderenfalls sollte der gereinigte Bereich bis zur kompletten Trocknung abgesperrt werden. Für große Räumlichkeiten ist der Einsatz von Reinigungsmaschinen empfehlenswert, um eine perfekte Reinigung und Hygiene sicherzustellen.

Der Bodenbelag gilt als sauber, wenn er wieder sein ursprüngliches Aussehen hat!



CASALGRANDE
PADANA
Pave your way