



*Perfect  
Wellness*

**effe**

BY EFFEGIBI

**effe**  
BY EFFEGIBI

→	7	Custom-Made		
→	45	BodyLove collection:		<a href="#">Indice</a>
	45	BodyLove SH		
	63	BodyLove S		
	75	BodyLove H		
→	93	Logica collection:	→	299
	93	Logica		299
	105	Logica SH		307
	113	Mid		
	125	Logica S		
	131	One S		
	141	Logica H	→	313
	147	One H		
	157	H		
				314
				315
				316
				323
→	167	Topkapi		326
				330
→	175	Effe Saune/Biosaune:	→	335
	175	Yoku		336
	187	Air		338
	203	Sky Corner		341
	213	SKy		342
	221	Auki		343
	231	Biosauna		344
				348
				350
→	233	Hammam:		
	235	Touch&Steam		
	247	Aquasteam		
	257	Easystem		
	267	Nuvola Smart Power		
	277	Nuvola		
	283	FeelGood		
	293	FitBox		

→	7	Custom-Made		
→	45	BodyLove collection:		<a href="#">Index</a>
	45	BodyLove SH		
	63	BodyLove S		
	75	BodyLove H		
→	93	Logica collection:	→	299
	93	Logica		299
	105	Logica SH		307
	113	Mid		
	125	Logica S		
	131	One S		
	141	Logica H	→	313
	147	One H		
	157	H		
				314
				315
				316
				323
→	167	Topkapi		326
				330
→	175	Effe Saunas/Bio-saunas:	→	335
	175	Yoku		336
	187	Air		338
	203	Sky Corner		341
	213	SKy		342
	221	Auki		343
	231	Bio-sauna		344
				348
				350
→	233	Hammam:		
	235	Touch&Steam		
	247	Aquasteam		
	257	Easystem		
	267	Nuvola Smart Power		
	277	Nuvola		
	283	FeelGood		
	293	FitBox		

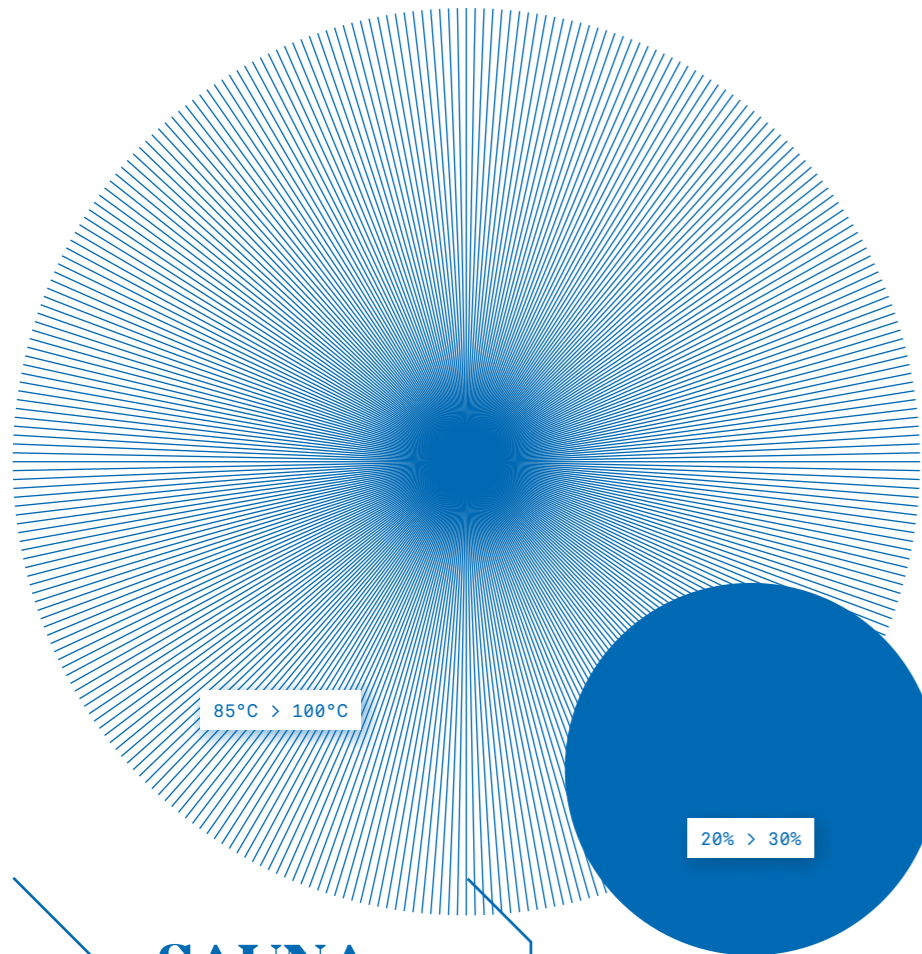

## SAUNA

La sauna finlandese è un rito che dal Nord Europa si è diffuso in tutto il mondo. Nella sauna il calore può raggiungere temperature fino ai 100°C, ma grazie alla bassa umidità (20-30%) si trasforma in un piacevole abbraccio che rilassa la muscolatura e favorisce la depurazione dell'organismo.

From its Scandinavian beginnings, the Finnish sauna has conquered the whole world. The heat in a sauna can reach temperatures up to 100°C but the low humidity (20-30%) transforms this into a pleasant embrace that relaxes the muscles and stimulates bodily purification.

20% > 30%

85°C > 100°C

## BIO SAUNA

La Biosauna è una sauna con livelli di temperatura contenuti tra i 50 e i 60°C e un'umidità di circa 60-70%. Grazie al vaporizzatore integrato, impostando la temperatura preferita, la stufa Bio creerà l'equilibrio perfetto fra calore ed umidità.

The Bio-sauna is a sauna whose temperature ranges from 50 to 60°C with humidity between 60-70%. The built-in vaporiser allows you to set your preferred temperature and the Bio heater creates the perfect balance between heat and humidity.

50°C > 60°C

60% > 70%

## HAMMAM

Al contrario della sauna, nel bagno turco l'umidità raggiunge il 100% e le temperature non superano i 48°C. L'azione contemporanea del vapore e del calore controllato aiuta la circolazione sanguigna linfatica sciogliendo le tossine e favorendone l'espulsione.

In contrast to the sauna, in the steam bath the humidity reaches 100% and the temperature never exceeds 48°C. The combined action of the steam and the controlled heat assists the blood and lymph circulation system, dissolving toxins and favouring their expulsion.

35°C > 48°C

90% > 100%

I prodotti Effe - by Effegibi - possono essere adattati a qualunque spazio: costruisci la tua personale area di benessere, ideata su misura per sfruttare al meglio ogni ambiente disponibile. Effe è in grado di realizzare progetti che prevedono la combinazione di saune, hammam, zone relax, bagno e doccia: il centro benessere ideale.

Effe - by Effegibi - products can be adapted to fit any space: create your own personal wellbeing area, tailor-made to make the very best use of the environment. Effe can produce designs combining saunas, Hammams, relaxation zones, baths and showers to create the perfect spa.

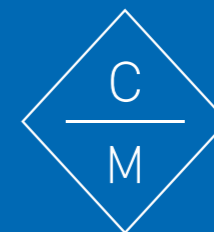

**Custom-Made**



Made-to-measure hammam.  
Private House, Ancona  
Italy



Made-to-measure sauna.  
Private House, Ancona  
Italy









Made-to-measure sauna.  
Golfo dei Poeti Relais  
Ameglia, Italy











Custom made spa with sauna, hammam, shower.  
Steam generator: Nuvola Smart Power.  
Door: Tuttovetro Inside, with built-in frame. Shower: FeelGood.









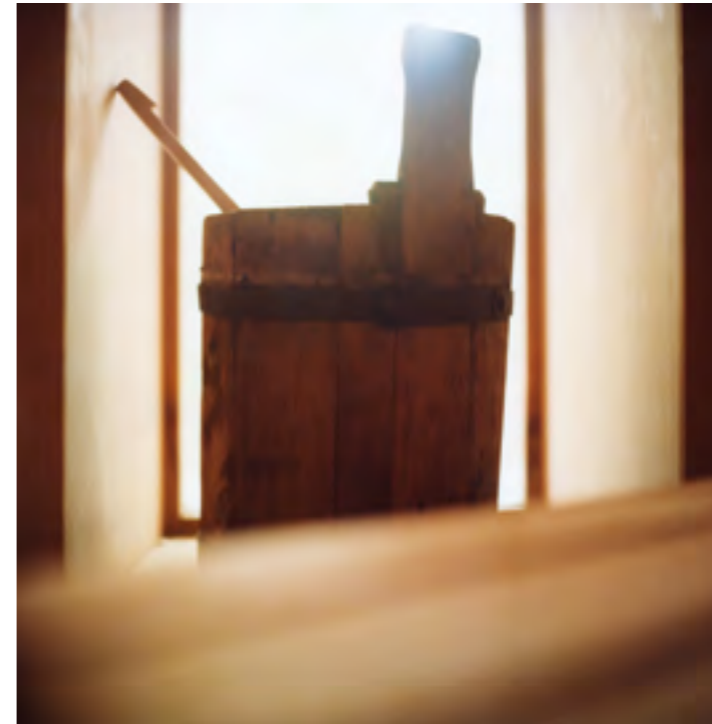

Made-to-measure sauna (private house).  
Corvara - Alta Badia  
Italy



Made-to-measure hammam (private house).  
Moscow  
Russian Federation



Made-to-measure hammam (private house).  
Saint Petersburg  
Russian Federation











## Materiali

### Sauna:

- Hemlock canadese;
- Legno massiccio termotrattato.

### Hammam:

- Grès porcellanato Champagne;
- Vetro a canne (flutes).

## Componenti Hammam

- Generatore Nuvola Smart Power ispezionabile dall'esterno.
- Pannello di comandi Touch.
- Vetri extrachiari 10 mm.
- Tetto in grès porcellanato.
- Panche bianche in Corian®.
- Cromoterapia a Led RGB.
- Soffione doccia rotondo.
- Base fonte in marmo Botticino.
- Ciotola fonte in acciaio cotto, color rame.

## Componenti Sauna

- Vetri extrachiari 10 mm.
- Panche in legno.
- Stufa con pietre.
- Copristufa in ceramica smaltata.
- Pannello di controllo finitura acciaio spazzolato.
- Mastellino e mestolo in legno.
- Clessidra.
- Impianto elettrico canalizzato.
- Illuminazione con cromoterapia a Led RGB, 5 colori fissi, 4 ciclidinamici e luce bianca.

## Materials

### Sauna:

- Canadian Hemlock;
- Heat-treated solid wood.

### Hammam:

- Grès porcelain Champagne;
- Fluted glass.

## Hammam includes

- Touch-screen control panel.
- Clear tempered glass 10 mm.
- Grès porcelain white top.
- White Corian® benches.
- Lighting system with Led RGB colour therapy.
- Ceiling mounted shower head.
- Spring whith Botticino marble.
- Copper-finish steel bowl.

## Sauna includes

- Clear tempered glass 10 mm.
- Wooden benches.
- Heater with stones.
- Ceramic tiles cover heater.
- Control panel with brushed steel finish.
- Wooden bucket and ladle.
- Hourglass.
- Electrical system with protected cable ducts.
- Led RGB lighting system, 5 fixed colours, 4 dynamic cycles and white light.

## Dimensioni

### Dimensions

#### BodyLove SH

Sauna+Hammam:  
393 x 176 x h 220 cm

#### BodyLove S

200 x 176 x h 220 cm

#### BodyLove H

200 x 176 x h 220 cm

#### Su misura

Custom size

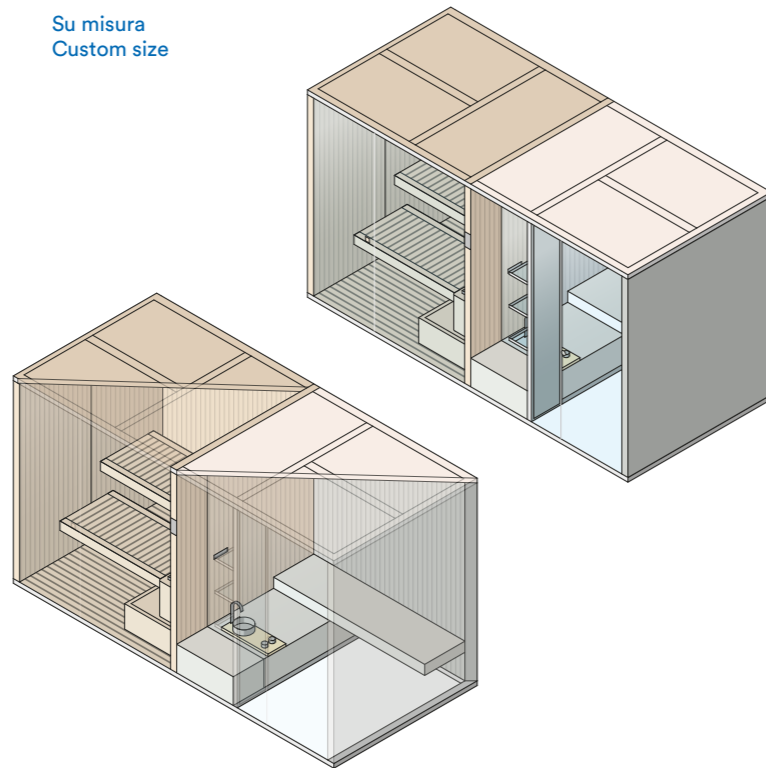



## BodyLove SH

Design: \_\_\_\_\_ Rodolfo Dordoni,  
Michele Angelini

Sistema modulare che unisce sauna, bagno turco, doccia: una vera spa personale, progettata per essere versatile ed elegante.

- > Componenti hammam di eccezionale qualità: grès porcellanato Champagne oppure vetro a canne, panche bianche in Corian®, accessori in Teck.
- > Finiture interne totalmente piastrellabili anche con altri rivestimenti per realizzazioni su misura.
- > Diverse possibilità di orientamento e posizionamento delle porte di accesso ai due spazi, per soluzioni personalizzate con l'area benessere.
- > BodyLove offre tantissime possibilità di personalizzazione in termini di scelta e abbinamento dei materiali.

The modular system combining sauna, steam bath and shower. A real personal spa designed for versatility and style.

- > Steam bath materials of outstanding quality: laminated grès porcelain Champagne or cane glass, Corian® white benches, teak accessories.
- > Internal walls available to be tiled with other materials for made to measure projects.
- > Number of options is available for positioning and orienting the access doors to the two spaces, for individual solutions within the wellness area.
- > BodyLove offers countless customization options as far as choice and combination of materials.



1 >



2 >







Sauna: heat-treated solid wood.  
Hamam: Corian® and Champagne grès porcelain.

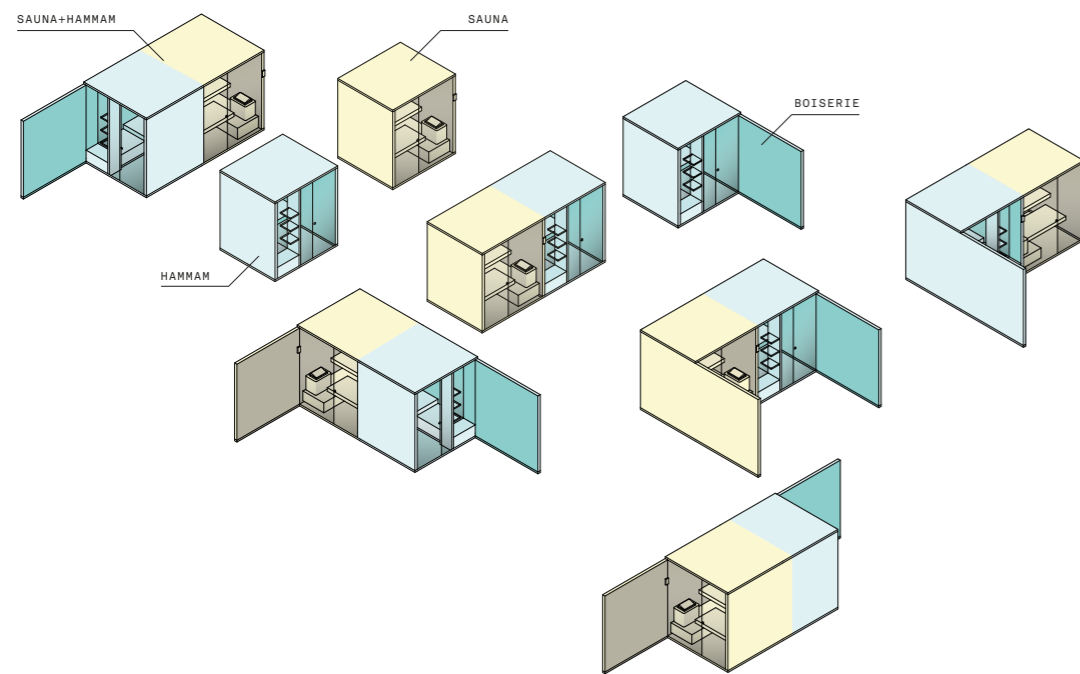

Sauna: heat-treated solid wood.  
 Hammam: Corian® and Champagne  
 grès porcelain.

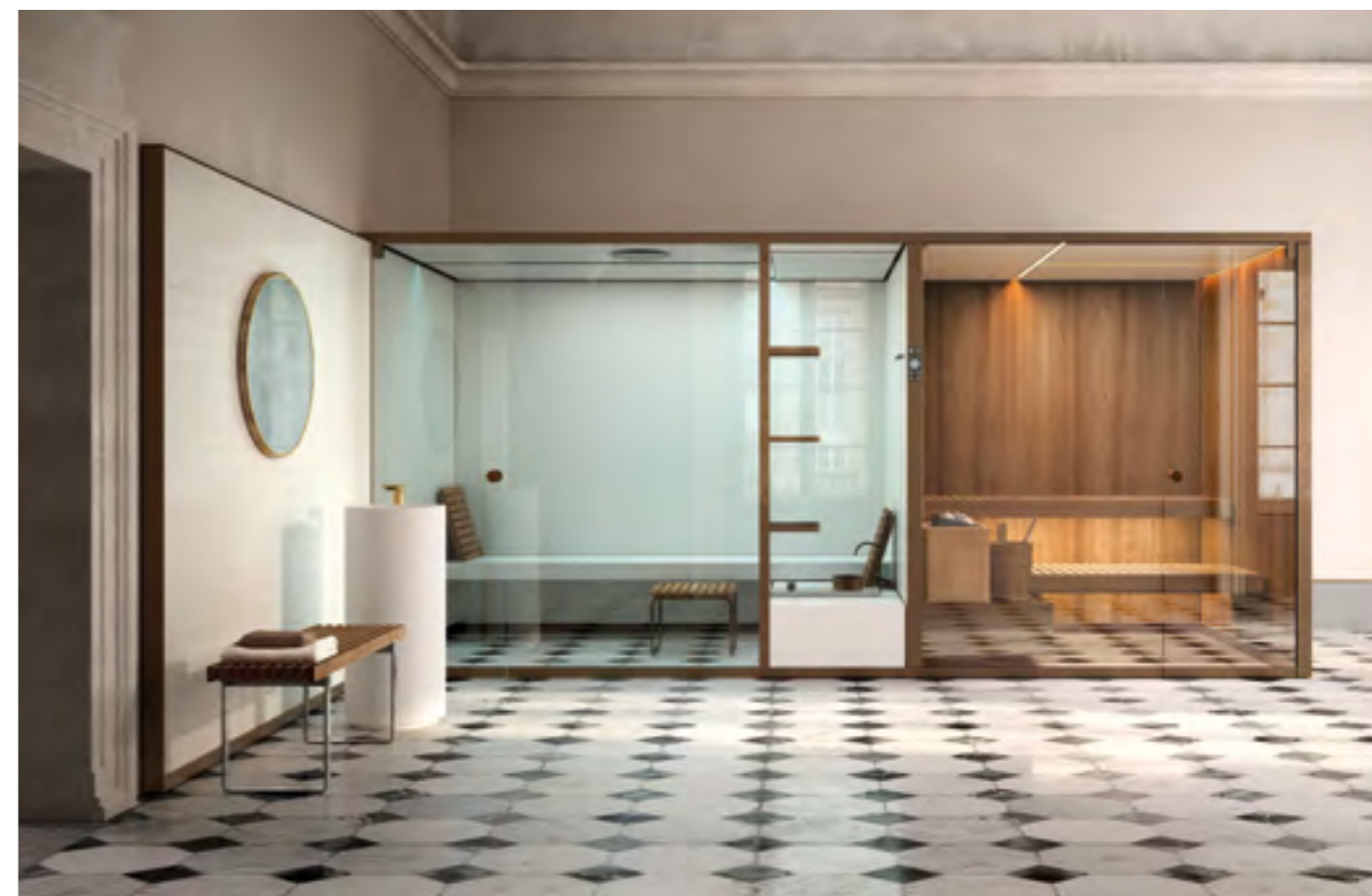

Sauna: heat-treated solid wood.  
 Hammam: Corian® and walls in customised  
 material.



Sauna: natural Canadian hemlock.



Hammam: Corian® and fluted glass.



# Materials

## Sauna

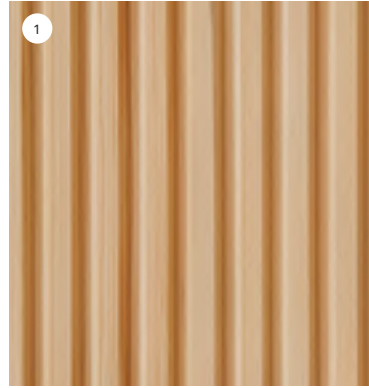

**Canadian Hemlock - BodyLove Texture**  
Sauna inside, panelling  
**Hemlock Canadese - Texture BodyLove**  
Interno sauna, boiserie

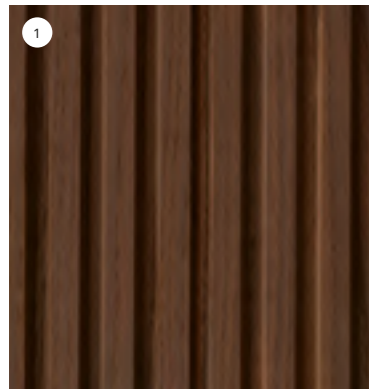

**Legno Massiccio Termotrattato - Texture BodyLove**  
Interno sauna, boiserie  
**Heat-Treated Solid Wood - BodyLove Texture**  
Sauna inside, panelling

## Hammam

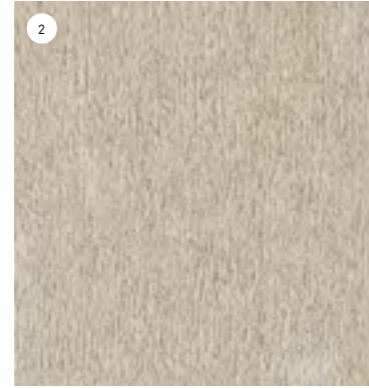

**Grès Porcellanato Champagne**  
Interno Hammam, Boiserie  
**Grès Porcelain Champagne**  
Hammam Inside, Panelling

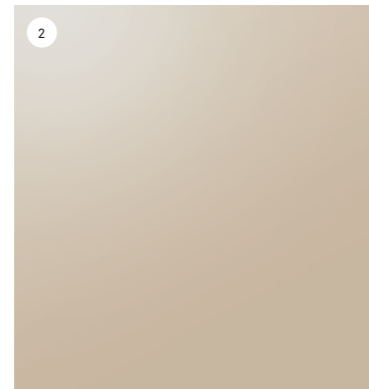

**Vetro liscio**  
Interno Hammam, Boiserie  
**Smooth glass**  
Hammam Inside, Panelling

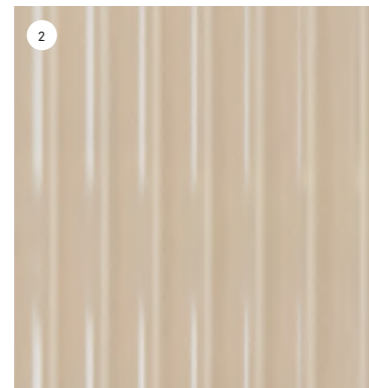

**Vetro a canne (Flutes)**  
Interno hammam, boiserie  
**Fluted Glass**  
Hammam inside, panelling

## Frame

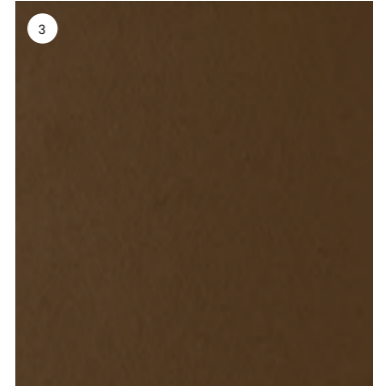

**Alluminio bronzo**  
Struttura  
**Aluminium bronze**  
Frame

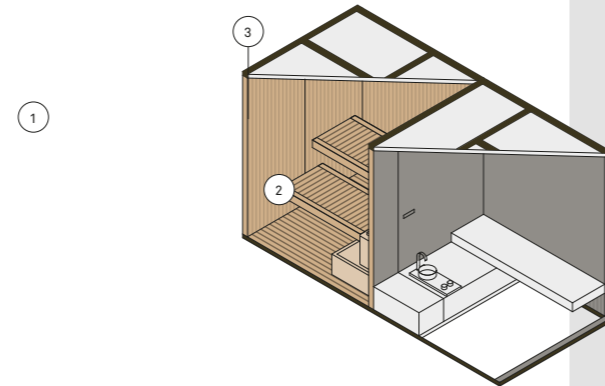

# Translations

## FRANÇAIS

### BodyLove

Système modulaire qui unit sauna, bain turc, douche : un véritable spa personnel, conçu pour être versatile et élégant.

### Caractéristiques :

Composants hammam de qualité exceptionnelle : grès porcelainé Champagne ou verre à flutes, banquettes blanches en Corian®, accessoires en Teck.  
Finitions internes à carreler entièrement même avec d'autres revêtements pour des réalisations sur mesure.  
Diverses possibilités d'orientation et de positionnement des portes d'accès aux deux espaces, pour des solutions personnalisées avec la zone bien-être.  
BodyLove offre un éventail de possibilités de personnalisation en termes de choix et d'assortiment des matériaux.

## DEUTSCH

### BodyLove

Modulares System, das Sauna, türkisches Dampfbad und Dusche miteinander vereint: ein wahres eigenes SPA, vielseitig und elegant.

### Beschreibung:

Hamam-Elemente von außergewöhnlicher Qualität: Steinzeug Champagne oder Ornamentglas, weiße Bänke aus Corian®, Zubehör aus Teak.  
Innenausführungen gänzlich und für Projekte nach Maß auch mit anderen Verkleidungen verfließbar.  
Verschiedene Ausrichtungs- und Positionierungsmöglichkeiten der Türen zu beiden Bereichen für Lösungen mit individuell gestaltetem Wellnessbereich.  
BodyLove bietet viele Gestaltungsmöglichkeiten hinsichtlich der Wahl und Kombination der Materialien.

## ESPAÑOL

### BodyLove

Sistema modular que une sauna, baño turco y ducha: una auténtica spa personal, diseñada para ser versátil y elegante.

### Características:

Componentes hammam de gran calidad: gres porcelánico Champagne o bien vidrio ondulado, bancos blancos en Corian® y accesorios en Teca.  
Acabados internos completamente embaldosables también con otros revestimientos para proyectos a medida.  
Diversas posibilidades de orientación y posicionamiento de las puertas de acceso a los dos espacios, para soluciones personalizadas con el área bienestar.  
BodyLove ofrece muchas posibilidades de personalización en términos de selección y combinación de los materiales.

## РУССКИЙ

### BodyLove

Модульная система, включающая сауну, турецкую баню, душ: настоящий спа-салон для личного пользования.

### Характеристики:

Материалы высочайшего качества для хаммама: керамогранит оттенка Champagne или трубчатое стекло, белые скамейки из Corian®, аксессуары из тика.  
Все внутренние поверхности могут быть облицованы другими материалами по индивидуальному проекту.  
Различные варианты размещения и направления дверей для доступа к двум зонам.  
Система BodyLove позволяет максимально персонализировать Ваше спа-пространство за счет широкого выбора сочетаемых между собой материалов.

## 中文

### BodyLove

结合桑拿浴、土耳其浴、淋浴为一体的整体模块系统：一款设计优雅而多变的真正专属私人洗浴空间

### 特点:

土耳其浴室采用优质材料：香槟色柘瓷或槽纹玻璃、Corian® 材质的白色板凳，以及柚木配件。  
内部可以采用全瓷砖设计或其他类型的定制墙面覆层。  
进出两个空间的门有多种位置和朝向可供选择，作为健身区域的独立解决方案。  
BodyLove 提供无数的定制选项，以及不同的材料组合。



#### Materiali

##### Sauna:

Hemlock canadese;  
Legno massiccio termotrattato.  
Piastrabile internamente anche  
con altri rivestimenti.

#### Componenti Sauna

Vetri extrachiari 10 mm.  
Panche in legno.  
Stufa con pietre.  
Copristufa in ceramica smaltata.  
Pannello di controllo finitura acciaio spazzolato.  
Mastellino e mestolo in legno.  
Clessidra.  
Impianto elettrico canalizzato.  
Illuminazione con cromoterapia a Led RGB,  
5 colori fissi, 4 cicli dinamici e luce bianca.

#### Materials

##### Sauna:

Canadian Hemlock;  
Heat-treated solid wood.  
It is possible to apply different  
claddings internally.

#### Sauna includes

Clear tempered glass 10 mm.  
Wooden benches.  
Heater with stones.  
Ceramic tiles cover heater.  
Control panel with brushed steel finish.  
Wooden bucket and ladle.  
Hourglass.  
Electrical system with protected cable ducts.  
Led RGB lighting system, 5 fixed colours,  
4 dynamic cycles and white light.

#### Dimensioni Dimensions

BodyLove S  
200 x 176 x h 220 cm  
8,0 kW max

Su misura  
Custom size

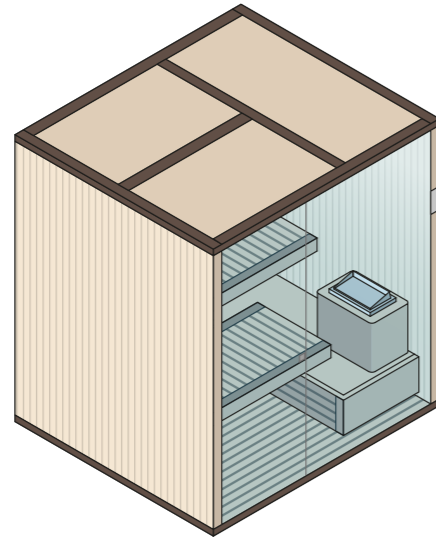

## BodyLove S

Design: \_\_\_\_\_ Rodolfo Dordoni,  
Michele Angelini

BodyLove S fa parte del sistema modulare progettato da Rodolfo Dordoni e Michele Angelini: è una sauna dotata di grande eleganza, curata nei minimi dettagli, che si integra molto facilmente con diversi tipi di ambiente, dalla zona living alle spa private o pubbliche.

> Sauna dal design unico, in grado di conferire all'ambiente forte personalità e grande eleganza.

> La stufa della sauna di BodyLove è rivestita in ceramica smaltata, con cromie uniche: un materiale di pregio che esalta la morbida bellezza del legno.

BodyLove S is part of the modular system designed by Rodolfo Dordoni and Michele Angelini: no detail of this elegant sauna has been left to chance and it blends effortlessly into any environment, from living areas to private or public spas.

> This sauna, with its unique design, makes a bold, elegant statement in any room.

> The BodyLove sauna heater is covered in glazed ceramic in unique colour combinations, a luxury material that enhances the soft beauty of the wood.







Led RGB lighting system,  
5 fixed colours, 4 dynamic  
cycles and white light.

Control panel with brushed  
steel finish.

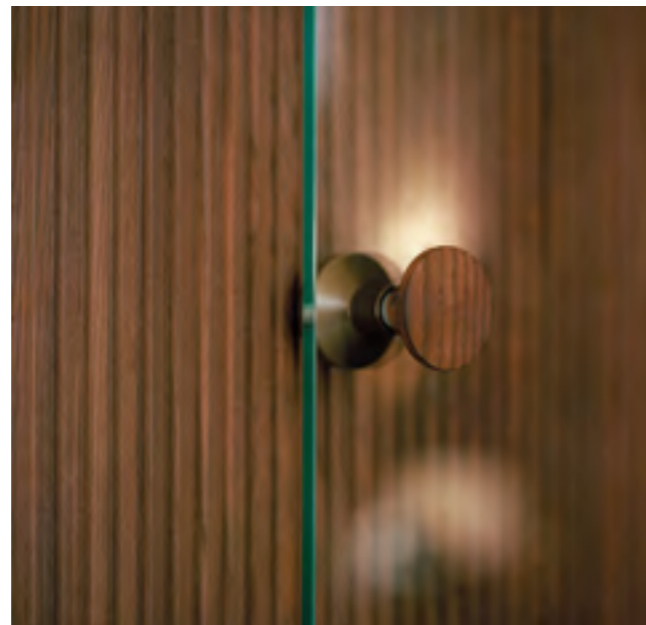



The heater is covered in glazed ceramic in unique colour combinations.



## Materials



**Hemlock Canadese - Texture BodyLove**  
Interno sauna, boiserie  
**Canadian Hemlock - BodyLove Texture**  
Sauna inside, panelling

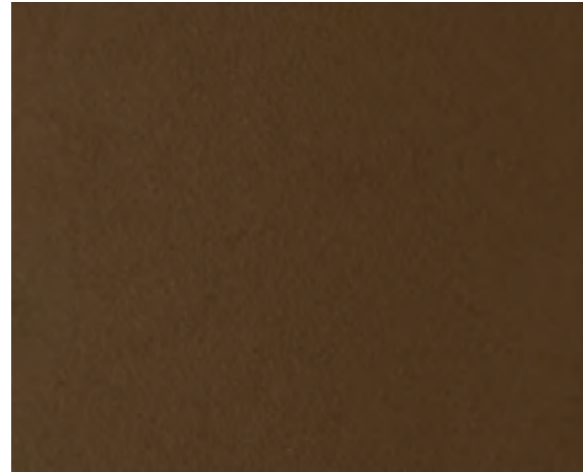

**Alluminio bronzo**  
Struttura  
**Aluminium bronze**  
Frame

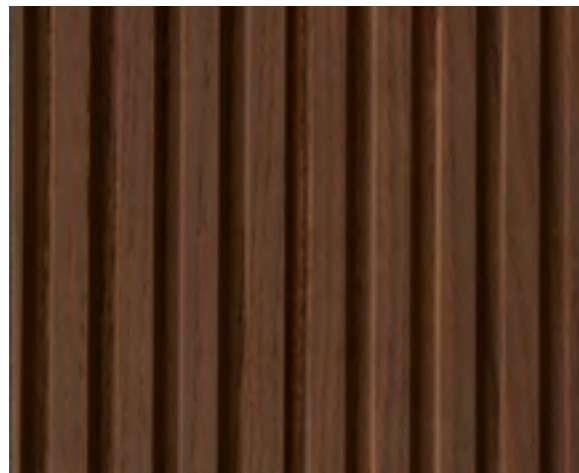

**Legno Massiccio Termotrattato - Texture BodyLove**  
Interno sauna, boiserie  
**Heat-Treated Solid Wood - BodyLove Texture**  
Sauna inside, panelling

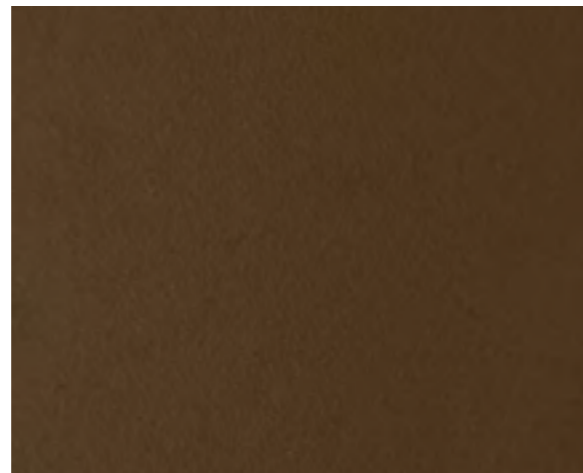

**Alluminio bronzo**  
Struttura  
**Aluminium bronze**  
Frame

## Translations

### FRANÇAIS

#### BodyLove S

BodyLove S fait partie du système modulaire conçu par Rodolfo Dordoni et Michele Angelini : il s'agit d'un sauna d'une grande élégance, soigné dans les moindres détails, qui s'intègre facilement à différents types d'environnement, du salon aux spas privés ou publics.

#### Caractéristiques :

Le poêle du sauna de BodyLove est revêtu en céramique émaillée, avec des couleurs uniques : un matériau précieux qui exalte la douce beauté du bois.  
Un sauna au design unique, en mesure de conférer à l'environnement une forte personnalité et une grande élégance.

### DEUTSCH

#### BodyLove S

BodyLove S ist Teil des von Rodolfo Dordoni und Michele Angelini entwickelten modularen Systems. Diese sehr elegante Sauna überzeugt durch die Liebe zum Detail und lässt sich leicht in verschiedene Umgebungen einfügen – vom Living-Bereich bis zu den privaten oder öffentlichen SPAs.

#### Beschreibung:

Eine Sauna mit einzigartigem Design, die dem Raum eine starke Persönlichkeit und große Eleganz gibt.  
Der Saunaofen von BodyLove ist in emaillierter Keramik und einzigartigen Farben gekleidet: ein edles Material, das die Weichheit des Holzes unterstreicht.

### ESPAÑOL

#### BodyLove S

BodyLove S forma parte del sistema modular diseñado por Rodolfo Dordoni y Michele Angelini. Se trata de una sauna de gran elegancia, cuidada en los mínimos detalles y que se integra muy fácilmente con diversos tipos de ambiente, desde la zona de día a las SPA privadas o públicas.

#### Características:

Sauna de diseño único, capaz de dar al ambiente una fuerte personalidad y una gran elegancia.  
La estufa de la sauna de BodyLove está revestida con cerámica esmaltada, con colores únicos: un material de valor que destaca la suave belleza de la madera.

### РУССКИЙ

#### BodyLove S

BodyLove S является частью модульной системы, разработанной архитектором Родольфо Дордони и дизайнером Микеле Анджелини. Продуманная до малейших деталей система легко интегрируется в любой интерьер: начиная от гостиной и заканчивая домашним или коммерческим спа-салонам.

#### Характеристики:

Сауна с уникальным дизайном придаст любому интерьеру яркую индивидуальность и благородную элегантность.  
Каменка сауны BodyLove отделана эмалированной керамикой уникальных оттенков: этот благородный материал подчеркнет природную красоту дерева.

### 中文

#### BodyLove S

BodyLove S 属于 Rodolfo Dordoni 和 Michele Angelini 设计的模块化系统: 这款优雅的桑拿房有着精心设计的细节, 可以轻松融入不同的安装环境, 不论是个人的生活区域, 还是私人或开放的水疗空间。

#### 特点:

这款桑拿房有着独特的设计, 在任何空间中都能展现出大胆而优雅个性。BodyLove 系列桑拿炉外饰面选用色彩独特的上釉的瓷砖: 这种优质材料更加凸显出木材的柔美。

#### Materiali

##### Interni:

grès porcellanato Champagne;  
vetro a canne (flutes).

Struttura: alluminio bronzo.

Piastrellabile internamente anche  
con altri rivestimenti.

#### Caratteristiche/Componenti

Generatore Nuvola Smart Power,  
ispezionabile dall'esterno.

Pannello di comandi touch.

Vetri extrachiari 10 mm.

Tetto in grès porcellanato.

Panche in Corian® bianco.

Cromoterapia a Led RGB.

Soffione doccia rotondo.

Base fonte in marmo Botticino.

Ciotola fonte in acciaio cotto, color rame.

#### Materials

##### Inside and panelling:

grès porcelain Champagne;  
fluted glass.

Frame: aluminium Bronze.

It is possible to apply different  
claddings internally.

#### Features/Components

Built in steam generator Nuvola Smart Power.

Touch-screen control panel.

Clear tempered glass 10 mm.

Grès porcelain white top.

White Corian® benches.

Lighting system with Led RGB colour therapy.

Ceiling mounted shower head.

Spring white Botticino marble and copper-finish  
steel bowl.

#### Dimensioni

##### Dimensions

##### BodyLove H

200 x 176 x h 220 cm

7 kW max

Su misura

Custom size

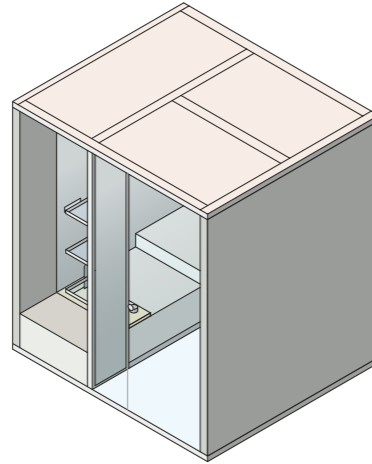

## BodyLove H

Design: \_\_\_\_\_ Rodolfo Dordoni,  
Michele Angelini

BodyLove H fa parte del sistema modulare progettato da Rodolo Dordoni e Michele Angelini: uno spazio hammam dalle linee pulite, realizzato con materiali di altissimo pregio, versatile e compatto. La cabina può essere applicata su pavimenti preesistenti, per una perfetta integrazione degli ambienti.

> Per la generazione del vapore BodyLove H utilizza la tecnologia Nuvola Smart Power, ispezionabile dall'esterno.

> Finiture interne totalmente piastrellabili anche con altri rivestimenti per realizzazioni su misura.

> Componenti di eccezionale qualità: grès porcellanato Champagne oppure vetro a canne, panche bianche in Corian®, accessori in Teck.

BodyLove H is part of the modular system designed by Rodolfo Dordoni and Michele Angelini: it is a versatile, compact Hammam space with clean lines and top-quality materials.

The cubicle can be mounted on existing floors, blending in perfectly with the room.

> Hammam technology equipped with Nuvola Smart Power steam generator, accessible from outside.

> Internal walls available to be tiled with other materials for made to measure projects.

> Materials of outstanding quality: laminated grès porcelain Champagne or cane glass, Corian® white benches, teak accessories.









A panel of Botticino marble contains the taps and the spring and shower controls plus a copper-finish stainless steel bowl to douse yourself with cool water as you take your steam bath.



Finishes: Corian® benches and fluted glass painted on the back



Accessories in Teak wood

Ceiling mounted shower head



BodyLove bench



Touch-screen control panel

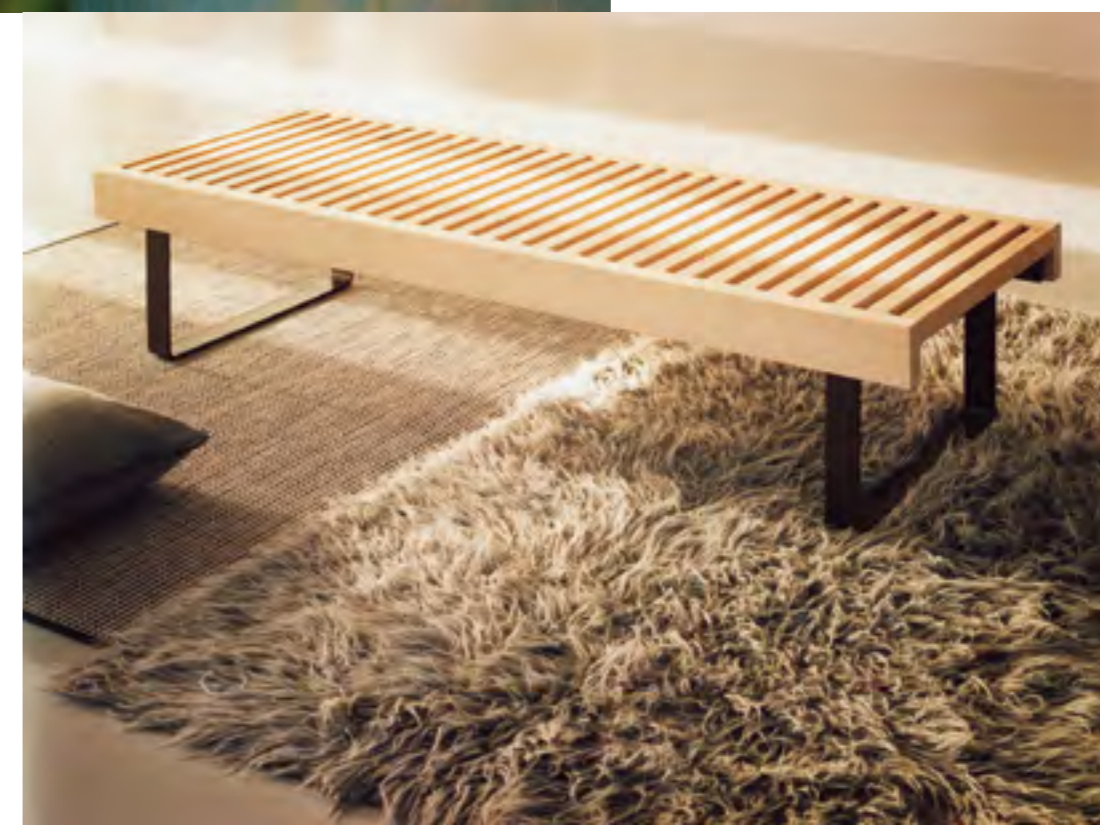



Finish: grès porcelain Champagne. Led RGB lighting system, 5 fixed colours, 4 dynamic cycles and white light.

84

BodyLove H / hammam /

85

### SH01



CANADIAN HEMLOCK  
HEMLOCK CANADESE



CHAMPAGNE GRÈS  
PORCELAIN  
GRES PORCELLANATO  
CHAMPAGNE

SAUNA (1), HAMMAM (1), WOOD /  
ALUMINIUM LOUNGER (1), HAMMAM  
FOOTREST (1), HEADREST / BACKREST  
(1), TOWEL STAND (1)

### SH03



CANADIAN HEMLOCK  
HEMLOCK CANADESE



FLUTED GLASS  
VETRO A CANNE

SAUNA (1), HAMMAM (1), WOOD /  
ALUMINIUM LOUNGER (1), HAMMAM  
FOOTREST (1), HEADREST / BACKREST  
(1), TOWEL STAND (1)

### SH07



CANADIAN HEMLOCK  
HEMLOCK CANADESE



CHAMPAGNE GRÈS  
PORCELAIN  
GRES PORCELLANATO  
CHAMPAGNE

SAUNA (1), HAMMAM (1), WOOD /  
ALUMINIUM LOUNGER (1), TABLE (1),  
HAMMAM FOOTREST (1), HEADREST /  
BACKREST (1), TOWEL STAND (1)

### SH09

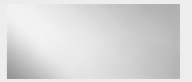

MIRROR  
SPECCHIO



CANADIAN HEMLOCK  
HEMLOCK CANADESE



FLUTED GLASS  
VETRO A CANNE

SAUNA (1), HAMMAM (1), WOOD /  
ALUMINIUM LOUNGER (1), TABLE (1),  
HAMMAM FOOTREST (1), HEADREST /  
BACKREST (1), TOWEL STAND (1)

### SH04



HEAT-TREATED  
SOLID WOOD  
LEGNO MASSICCIO  
TERMOTRATTATO



CHAMPAGNE GRÈS  
PORCELAIN  
GRES PORCELLANATO  
CHAMPAGNE

SAUNA (1), HAMMAM (1), WOOD /  
ALUMINIUM LOUNGER (1), HAMMAM  
FOOTREST (1), HEADREST / BACKREST  
(1), TOWEL STAND (1)

### SH06



HEAT-TREATED  
SOLID WOOD  
LEGNO MASSICCIO  
TERMOTRATTATO



FLUTED GLASS  
VETRO A CANNE

SAUNA (1), HAMMAM (1), WOOD /  
ALUMINIUM LOUNGER (1), HAMMAM  
FOOTREST (1), HEADREST / BACKREST  
(1), TOWEL STAND (1)

### SH10



HEAT-TREATED  
SOLID WOOD  
LEGNO MASSICCIO  
TERMOTRATTATO



CHAMPAGNE GRÈS  
PORCELAIN  
GRES PORCELLANATO  
CHAMPAGNE

SAUNA (1), HAMMAM (1), WOOD /  
ALUMINIUM LOUNGER (1), HAMMAM  
FOOTREST (1), HEADREST / BACKREST  
(1), TOWEL STAND (1)

### SH12



HEAT-TREATED  
SOLID WOOD  
LEGNO MASSICCIO  
TERMOTRATTATO



FLUTED GLASS  
VETRO A CANNE

SAUNA (1), HAMMAM (1), WOOD /  
ALUMINIUM LOUNGER (1), TABLE (1),  
HAMMAM FOOTREST (1), HEADREST /  
BACKREST (1), TOWEL STAND (1)

### SPA01



CANADIAN HEMLOCK  
HEMLOCK CANADESE



CHAMPAGNE GRÈS  
PORCELAIN  
GRES PORCELLANATO  
CHAMPAGNE

SAUNA (1), HAMMAM (1), WOOD /  
ALUMINIUM LOUNGER (1), TABLE (1),  
HAMMAM FOOTREST (1), HEADREST /  
BACKREST (1), TOWEL STAND (1),  
FEELGOOD SHOWER (1)

### SPA03



MIRROR  
SPECCHIO



CANADIAN HEMLOCK  
HEMLOCK CANADESE



FLUTED GLASS  
VETRO A CANNE

SAUNA (1), HAMMAM (1), WOOD /  
ALUMINIUM LOUNGER (1), TABLE (1),  
HAMMAM FOOTREST (1), HEADREST /  
BACKREST (1), TOWEL STAND (1),  
FEELGOOD SHOWER (1)

### SPA07



MIRROR  
SPECCHIO



CANADIAN HEMLOCK  
HEMLOCK CANADESE



CHAMPAGNE GRÈS  
PORCELAIN  
GRES PORCELLANATO  
CHAMPAGNE

SAUNA (1), HAMMAM (1), BENCH (1),  
WOOD / ALUMINIUM LOUNGER (2),  
MESSAGE COUCH (1), TABLE (2),  
HAMMAM FOOTREST (2), HEADREST /  
BACKREST (2), TOWEL STAND (2),  
FEELGOOD SHOWER (2)

### SPA09



MIRROR  
SPECCHIO



CANADIAN HEMLOCK  
HEMLOCK CANADESE



FLUTED GLASS  
VETRO A CANNE

SAUNA (1), HAMMAM (1), BENCH (1),  
WOOD / ALUMINIUM LOUNGER (2),  
MESSAGE COUCH (1), TABLE (2),  
HAMMAM FOOTREST (2), HEADREST /  
BACKREST (2), TOWEL STAND (2),  
FEELGOOD SHOWER (2)

### SPA04



HEAT-TREATED  
SOLID WOOD  
LEGNO MASSICCIO  
TERMOTRATTATO



CHAMPAGNE GRÈS  
PORCELAIN  
GRES PORCELLANATO  
CHAMPAGNE

SAUNA (1), HAMMAM (1), WOOD /  
ALUMINIUM LOUNGER (1), TABLE (1),  
HAMMAM FOOTREST (1), HEADREST /  
BACKREST (1), TOWEL STAND (1),  
FEELGOOD SHOWER (1)

### SPA06



HEAT-TREATED  
SOLID WOOD  
LEGNO MASSICCIO  
TERMOTRATTATO



FLUTED GLASS  
VETRO A CANNE

SAUNA (1), HAMMAM (1), WOOD /  
ALUMINIUM LOUNGER (1), TABLE (1),  
HAMMAM FOOTREST (1), HEADREST /  
BACKREST (1), TOWEL STAND (1),  
FEELGOOD SHOWER (1)

### SPA10

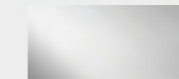

MIRROR  
SPECCHIO



HEAT-TREATED  
SOLID WOOD  
LEGNO MASSICCIO  
TERMOTRATTATO

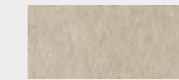

CHAMPAGNE GRÈS  
PORCELAIN  
GRES PORCELLANATO  
CHAMPAGNE

SAUNA (1), HAMMAM (1), BENCH (1),  
WOOD / ALUMINIUM LOUNGER (2),  
MESSAGE COUCH (1), TABLE (2),  
HAMMAM FOOTREST (2), HEADREST /  
BACKREST (2), TOWEL STAND (2),  
FEELGOOD SHOWER (2)

### SPA12

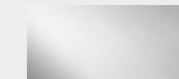

MIRROR  
SPECCHIO



HEAT-TREATED  
SOLID WOOD  
LEGNO MASSICCIO  
TERMOTRATTATO



FLUTED GLASS  
VETRO A CANNE

SAUNA (1), HAMMAM (1), BENCH (1),  
WOOD / ALUMINIUM LOUNGER (2),  
MESSAGE COUCH (1), TABLE (2),  
HAMMAM FOOTREST (2), HEADREST /  
BACKREST (2), TOWEL STAND (2),  
FEELGOOD SHOWER (2)

## Materials



**Grès porcellanato Champagne**  
Interno, boiserie  
**Grès Porcelain Champagne**  
Inside, panelling



**Alluminio bronzo**  
Struttura  
**Aluminium Bronze**  
Frame



**Vetro a canne (Flutes)**  
Interno, boiserie  
**Fluted Glass**  
Inside, panelling

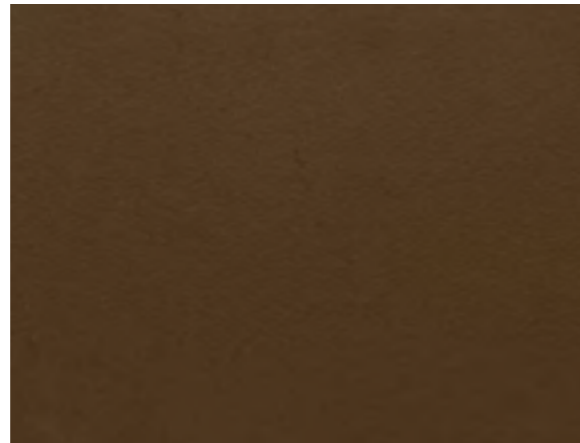

**Alluminio bronzo**  
Struttura  
**Aluminium Bronze**  
Frame



**Vetro liscio**  
Interno, boiserie  
**Smooth Glass**  
Inside, panelling

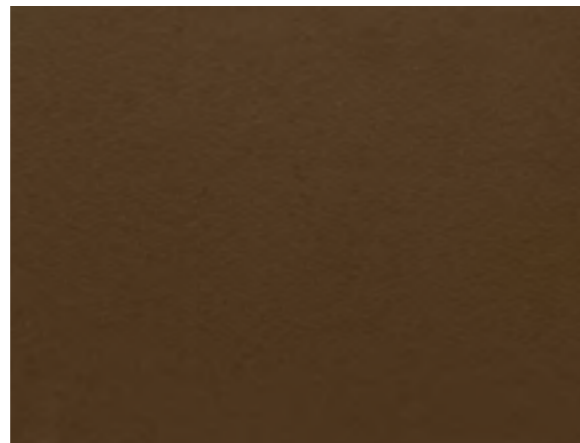

**Alluminio bronzo**  
Struttura  
**Aluminium Bronze**  
Frame

## Translations

### FRANÇAIS

#### BodyLove H

BodyLove H fait partie du système modulaire conçu par Rodolfo Dordoni et Michele Angelini : un espace hammam aux lignes épurées, réalisé avec des matériaux de la plus haute qualité, polyvalent et compact. La cabine peut être appliquée sur des sols préexistants, pour une intégration parfaite des environnements.

#### Caractéristiques :

Pour la production de vapeur, BodyLove H utilise la technologie Nuvola Smart Power (contrôlable depuis l'extérieur). Composants hammam de qualité exceptionnelle : grès porcelainé Champagne ou verre à flutes, banquettes blanches en Corian®, accessoires en Teck. Finitions internes à carreler entièrement même avec d'autres revêtements pour des réalisations sur mesure.

### DEUTSCH

#### BodyLove H

BodyLove H ist Teil des von Rodolfo Dordoni und Michele Angelini entworfenen modularen Systems. Dieser vielseitige und kompakte Hamam-Bereich mit klaren Linien wird aus höchstwertigen Materialien hergestellt. Die Kabine kann auf vorhandenen Böden positioniert und damit perfekt in den Raum integriert werden.

#### Beschreibung:

Für die Dampferzeugung nutzt BodyLove H die Nuvola Smart Power-Technologie (von außen inspizierbar). Hamam-Elemente von außergewöhnlicher Qualität: Steinzeug Champagne oder Ornamentglas, weiße Bänke aus Corian®, Zubehör aus Teak. Innenausführungen gänzlich und für Projekte nach Maß auch mit anderen Verkleidungen verfliesbar.

### ESPAÑOL

#### BodyLove H

BodyLove H forma parte del sistema modular diseñado por Rodolfo Dordoni y Michele Angelini. Se trata de un espacio hammam de líneas limpias, realizado con materiales de gran valor, versátil y compacto. La cabina se puede colocar sobre suelos preexistentes, de forma que se integre perfectamente con los demás ambientes.

#### Características:

Para la generación del vapor, BodyLove H utiliza la tecnología Nuvola Smart Power (inspeccionable desde el exterior). Componentes hammam de gran calidad: grés porcelánico Champagne o bien vidrio ondulado, bancos blancos en Corian® y accesorios en Teca. Acabados internos completamente embaldosables también con otros revestimientos para proyectos a medida.

### РУССКИЙ

#### BodyLove H

BodyLove H является частью модульной системы, спроектированной Родольфо Дордони и Микеле Анджелини: это хаммам, изготовленный из материалов высочайшего качества и характеризующийся универсальным, компактным и лаконичным дизайном. Кабина идеально интегрируется в любой интерьер и может быть установлена на уже имеющийся пол.

#### Характеристики:

В системе BodyLove H используется парогенератор Nuvola Smart Power (устанавливается снаружи и позволяет легко осуществлять осмотр и техобслуживание). Материалы высочайшего качества для хаммама: керамогранит оттенка Champagne или трубчатое стекло, белые скамейки из Corian®, аксессуары из тика. Все внутренние поверхности могут быть облицованы другими материалами по индивидуальному проекту.

### 中文

#### BodyLove H

BodyLove H 属于 Rodolfo Dordoni 和 Michele Angelini 设计的模块化系统: 这款功能全面、外形紧凑的土耳其浴室采用简洁的线条和优质的材料。该隔间可以直接安装地板上, 与房间完美融合。

#### 特点:

在蒸汽生成方面, Body Love H 采用 Nuvola Smart Power 技术 (可从外部进行检测)。土耳其浴室采用优质材料: 香槟色炻瓷或槽纹玻璃、Corian® 材质的白色板凳, 以及柚木配件。内部可以采用全瓷砖设计或其他类型的定制墙面覆层。

### Materiali

Sauna - interno ed arredi:

- Hemlock canadese;
- Porte in vetro temperato 8 mm.

Sauna - pedana:

- Grès laminato 3,5 mm accoppiato su vetro temperato 15 mm.

Hammam - interno ed arredi:

- Grès laminato 3,5 mm;
- Porte in vetro temperato 8 mm.

Hammam - pedana:

- Grès laminato 3,5 mm accoppiato su vetro temperato 15 mm.

Doccia - pedana:

- Grès laminato 3,5 mm accoppiato su vetro temperato 15 mm.

### Finiture esterne

Alluminio verniciato.

Pareti esterne a vista in grès laminato 3,5 mm.

### Componenti Sauna

Panche in legno.

Stufa con pietre.

Pannello di controllo touch.

Funzione Energy Saver automatica.

Mastellino integrato nella panca inferiore.

Mestolo in legno e clessidra.

Impianto elettrico canalizzato.

Illuminazione con cromoterapia a Led RGB,

- 5 colori fissi, 4 cicli dinamici e luce bianca.

### Componenti Hammam

Aquasteam 45.

Panche in grès laminato.

Illuminazione con cromoterapia a Led RGB,

- 5 colori fissi, 4 cicli dinamici e luce bianca.

### Componenti Doccia

Miscelatore con cartuccia progressiva e deviatore.

Soffione doccia a soffitto con anticalcare.

Doccia a mano.

### ECC - Effe Comfort Control

Sistema che consente di gestire a distanza sauna e hammam dal proprio dispositivo, tramite l'App Effegibi Experience. Disponibile su iOS.

### Materials

Sauna - inside and fittings:

- Canadian Hemlock;
- Doors in 8 mm tempered glass.

Sauna - platform:

- 3.5 mm laminated grès porcelain fitted to 15 mm toughened glass.

Hammam - inside and fittings:

- 3.5 mm laminated grès porcelain;
- Doors in 8 mm tempered glass.

Hammam - platform:

- 3.5 mm laminated grès porcelain fitted to 15 mm toughened glass.

Shower - platform:

- 3.5 mm laminated grès porcelain fitted to 15 mm toughened glass.

### Outside wall finish

Painted aluminium.

Outside wall finish laminated grès porcelain

- 3.5 mm.

### Sauna includes

Wooden benches.

Heater with stones.

Touch control panel.

Automatic Energy Saving function.

Bucket built into the lower bench.

Wooden ladle and hourglass.

Electrical system with protected cable ducts.

Lighting system with Led RGB colour therapy,  
5 fixed colours, 4 dynamic cycles, white light.

### Hammam includes

Aquasteam 45.

Unglazed porcelain tile benches.

Lighting system with Led RGB colour therapy,

- 5 fixed colours, 4 dynamic cycles and white light.

### Shower includes

Mixer tap with flow regulator and diverter.

Ceiling mounted anti-scale shower head.

Hand-held shower head.

### ECC - Effe Comfort Control

System that remotely controls the sauna and the steam bath from your device, using the Effegibi Experience app. Available on iOS.

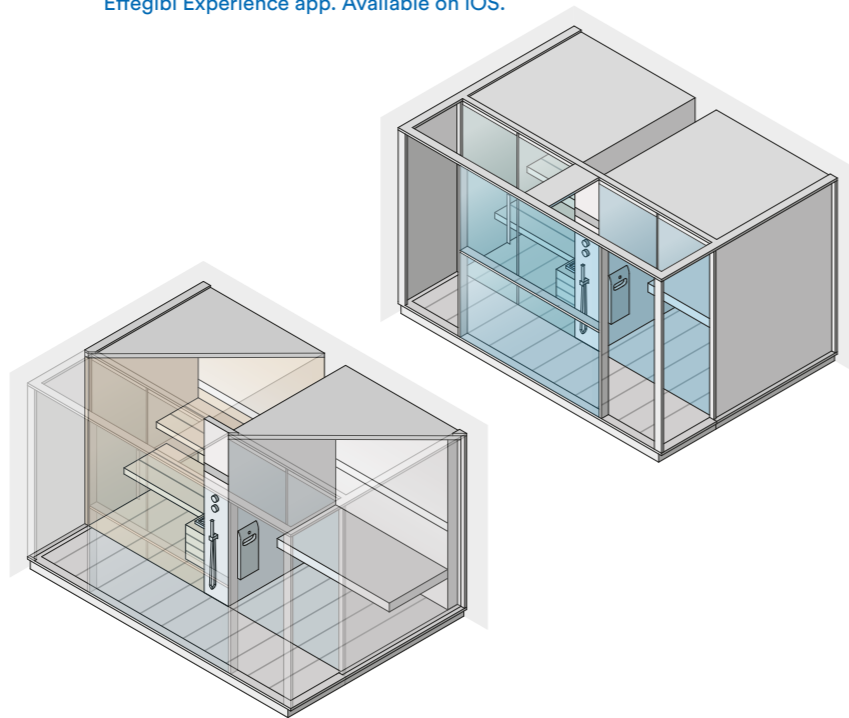

### Dimensioni e potenza assorbita Dimensions and absorbed power

#### Logica

373 x 250 x h 226 cm

10,5 kW max

230 Vac 1 N 50-60 Hz

400 Vac 3 N 50-60 Hz

Su misura

Custom size



## Logica

Design: \_\_\_\_\_ Talocci Design

Sauna e bagno turco in una soluzione unica, collegati da un elegante spazio doccia. Logica contiene tutte le funzioni di una spa completa con un perfetto equilibrio tra funzionalità, estetica e tecnologia.

- › Tecnologia Aquasteam per la generazione del vapore, per un controllo totale della qualità.

- › Doccia completa di soffione anticalcare e miscelatore con cartuccia progressiva e deviatore.

- › Materiali di eccezionale qualità: legno Hemlock canadese, rivestimenti in grès laminato Slimtech® da 3,5 mm, porte in vetro temperato da 8 mm.

- › Disponibile in sette finiture standard, o con cromie personalizzate.

A sauna and steam bath in one unit linked by a stylish shower space. Logica boasts all the functions of a complete spa, the perfect balance of practicality, aesthetics and technology.

- › Aquasteam steam generation technology, for total quality control.

- › Shower complete with lime-scale-resistant shower head, mixer tap with flow regulator and diverter.

- › Top quality materials: Canadian hemlock wood, tiling in 3.5 mm Slimtech® laminated grès porcelain, 8 mm toughened glass doors.

- › Available in seven standard finishes or personalised colour schemes.



1 >



2 >



Shower complete with mixer tap with flow regulator and diverter, ceiling-mounted lime-scale-resistant shower head, hand-held shower head.  
Finish: Stone.





Shower complete with mixer tap with flow regulator and diverter, ceiling-mounted lime-scale-resistant shower head, hand-held shower head.

## Materials

### SAND

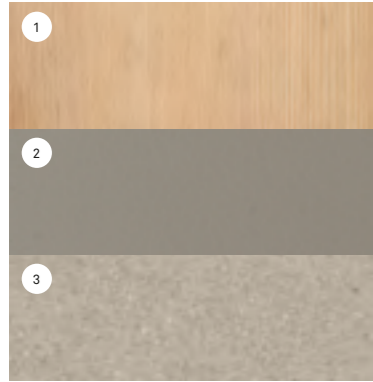

**SOFT SAND**  
Canadian Hemlock (Smooth)  
Painted Aluminium (Gray) Ral 7030  
Slimtech Soft Sand

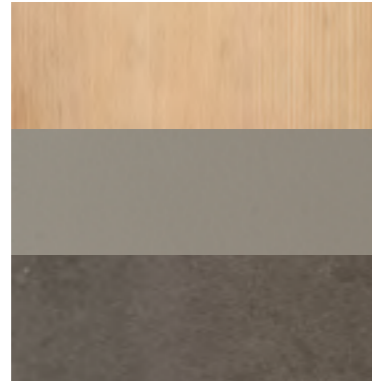

**SAND C030**  
Canadian Hemlock (Smooth)  
Painted Aluminium (Gray) Ral 7030  
Slimtech Re-Evolution C030

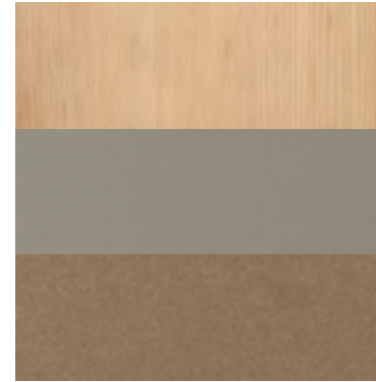

**SAND W030**  
Canadian Hemlock (Smooth)  
Painted Aluminium (Gray) Ral 7030  
Slimtech Re-Evolution W030

### CLOUD



**WHITE CLOUD**  
Canadian Hemlock (Smooth)  
Painted Aluminium (White) Ral 9010  
SA810G  
Slimtech White Cloud

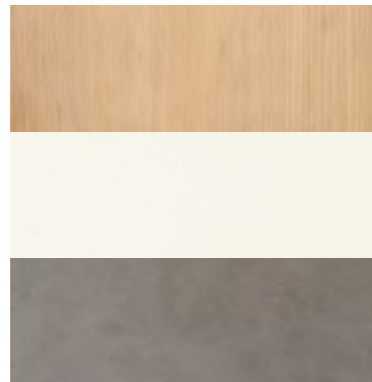

**CLOUD C020**  
Canadian Hemlock (Smooth)  
Painted Aluminium (White) Ral 9010  
SA810G  
Slimtech Re-Evolution C020



**CLOUD W030**  
Canadian Hemlock (Smooth)  
Painted Aluminium (White) Ral 9010  
SA810G  
Slimtech Re-Evolution W030

### STONE



Canadian Hemlock (Smooth)  
Painted Aluminium (Brown) YX355F  
YX355F 2525 Sablé  
Slimtech Black Stone

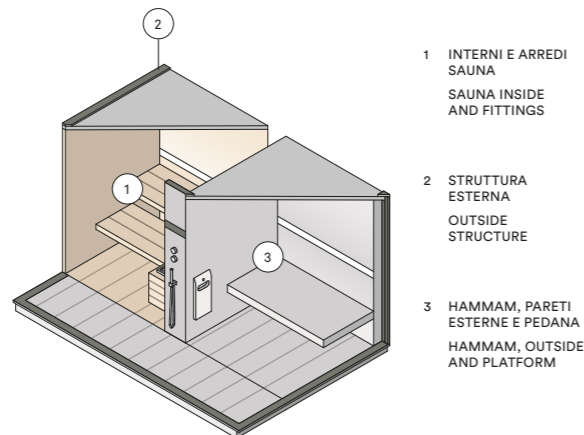

## Translations

### FRANÇAIS

#### Logica

Sauna et bain turc en une solution unique, reliés par un espace douche élégant. Logica contient toutes les fonctions d'un centre de bien-être complet, en maintenant un parfait équilibre entre fonctionnalité, esthétique et technologie.

#### Caractéristiques :

Technologie Aquasteam pour la production de vapeur, pour un contrôle total de la qualité.

Douche dotée de pomme de douche anticalcaire et mitigeur à cartouche progressive et inverseur.

Matériaux de qualité exceptionnelle : bois Hemlock canadien, revêtements en grès laminé Slimtech® de 3,5 mm, portes en verre trempé de 8 mm.

Disponible en sept finitions standard, ou avec des couleurs personnalisées.

### DEUTSCH

#### Logica

Sauna und türkisches Dampfbad in einer einzigen Lösung und verbunden über einen eleganten Duschbereich.

Logica bietet alle Funktionen eines kompletten Wellnesscenters und bewahrt dabei Funktionalität, Design und Technologie in einem perfekten Gleichgewicht.

#### Beschreibung:

Dampferzeugung mit Aquasteam-Technologie für eine absolute Qualitätskontrolle.

Dusche mit Deckenbrause mit Anti-Kalk-System und Mischer mit Einhebelregulierung und Umsteller.

Materialien von außergewöhnlicher Qualität: kanadisches Hemlock-Holz; Verfließungen aus laminiertem Feinsteinzeug Slimtech®, 3,5 mm; Türen aus gehärtetem Glas, 8 mm.

Erhältlich in sieben Standardausführungen oder mit individueller Farbgestaltung.

### ESPAÑOL

#### Logica

Sauna y baño turco en una única solución, unidos por un elegante espacio ducha. Logica contiene todas las funciones de un centro de bienestar completo, manteniendo un perfecto equilibrio entre funcionalidad, estética y tecnología.

#### Características:

Tecnología Aquasteam para la generación del vapor, para un control total de la calidad.

Ducha equipada con alcachofa anticalcárea y mezclador con cartucho progresivo y desviador.

Materiales de calidad excepcional: madera Hemlock canadiense, revestimientos en gres laminado Slimtech® de 3,5 mm, puertas en vidrio templado de 8 mm.

Disponible en siete acabados estándar o con colores personalizados.

### РУССКИЙ

#### Logica

Сауна, турецкая баня и элегантный душ в едином пространстве.

Модель Logica выполняет все функции полноценного спа-центра, сочетая в себе функциональность, эстетику и высокие технологии.

#### Характеристики:

Парогенератор Aquasteam, позволяющий максимально управлять качеством пара.

Душевая лейка потолочной фиксации с функцией защиты от известкового налета, прогрессивный смеситель и дивертор.

Материалы превосходного качества: канадский хемлок, отделка из ламинированного керамогранита Slimtech® 3,5 мм, двери из закаленного стекла 8 мм.

Три стандартных варианта отделки или отделка по индивидуальному заказу.

### 中文

#### Logica

在一个解决方案中将桑拿浴与土耳其浴两种功能结合起来，并附带一个优雅美观的淋浴走廊空间。Logica系列涵盖了SPA养生的所有功能，并将美观、科技与功能进行了完美结合。

#### 特点:

Aquasteam系列蒸汽发生器，全方位监控以提供高品质蒸汽。

淋浴花洒采用防水垢堵塞技术，并配置渐进式阀芯的控水器和分水器等。

选用优质材料：使用加拿大铁杉木，厚度为3.5mm的Slimtech®超薄陶瓷层压板，以及经过淬火处理的8mm厚的钢化玻璃门板。

提供三种标准的外观效果，或进行个人定制颜色。

#### Materiali

Sauna - interno ed arredi:

- Hemlock canadese;
- Porte in vetro temperato 8 mm.

Sauna - pedana:

- Grès laminato 3,5 mm accoppiato su vetro temperato 15 mm.

Hammam - interno ed arredi:

- Grès laminato 3,5 mm;
- Porte in vetro temperato 8 mm.

Hammam - pedana:

- Grès laminato 3,5 mm accoppiato su vetro temperato 15 mm.

#### Finiture esterne

Alluminio verniciato.

Pareti esterne a vista in grès laminato 3,5 mm.

#### Componenti Sauna

Panche in legno.

Stufa con pietre.

Pannello di controllo touch.

Funzione Energy Saver automatica.

Mastellino integrato nella panca inferiore.

Mestolo in legno e clessidra.

Impianto elettrico canalizzato.

Illuminazione con cromoterapia a Led RGB,

- 5 colori fissi, 4 cicli dinamici e luce bianca.

#### Componenti Hammam

Aquasteam 45.

Panche in grès laminato.

Illuminazione con cromoterapia a Led RGB,

- 5 colori fissi, 4 cicli dinamici e luce bianca.

#### ECC - Effe Comfort Control

Sistema che consente di gestire a distanza sauna e hammam dal proprio dispositivo, tramite l'App Effegibi Experience. Disponibile su iOS.

#### Hammam includes

Aquasteam 45.

Unglazed porcelain tile benches.

Lighting system with Led RGB colour therapy,

- 5 fixed colours, 4 dynamic cycles and white light.

#### ECC - Effe Comfort Control

System that remotely controls the sauna and the steam bath from your device, using the Effegibi Experience app. Available on iOS.

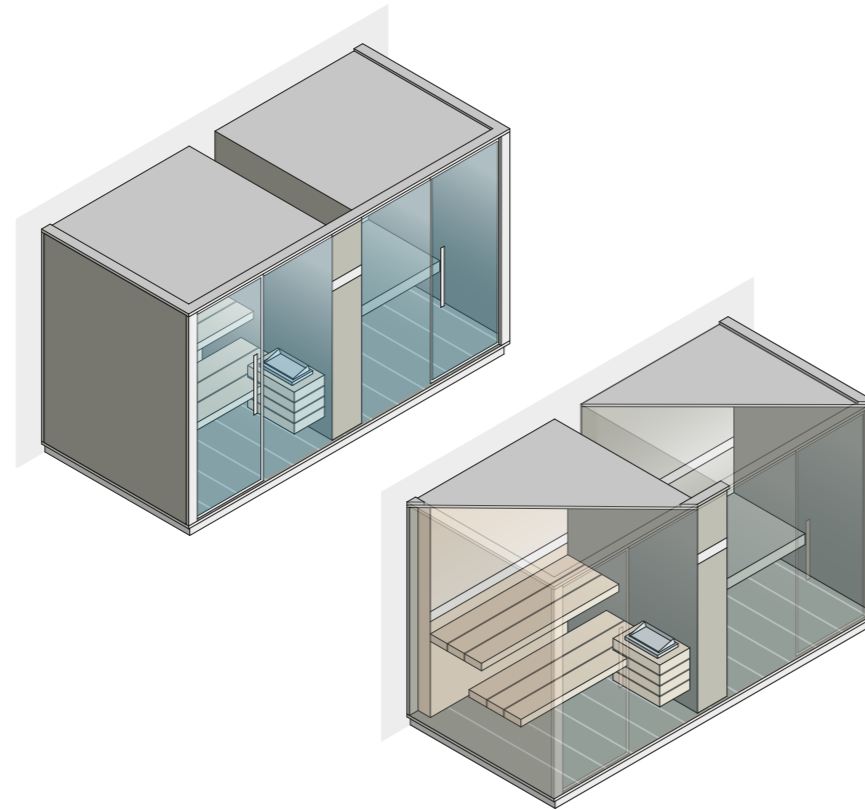

#### Materials

Sauna - inside and fittings:

- Canadian Hemlock;
- Doors in 8 mm tempered glass.

Sauna - platform:

- 3.5 mm laminated grès porcelain fitted to 15 mm toughened glass.

Hammam - inside and fittings:

- 3.5 mm laminated grès porcelain;
- Doors in 8 mm tempered glass.

Hammam - platform:

- 3.5 mm laminated grès porcelain fitted to 15 mm toughened glass.

#### Outside wall finish

Painted aluminium.

Outside wall finish laminated grès porcelain 3.5 mm.

#### Sauna includes

Wooden benches.

Heater with stones.

Touch control panel.

Automatic Energy Saving function.

Bucket built into the lower bench.

Wooden ladle and hourglass.

Electrical system with protected cable ducts.

Lighting system with Led RGB colour therapy,

- 5 fixed colours, 4 dynamic cycles and white light.

#### Dimensioni e potenza assorbita Dimensions and absorbed power

##### Logica SH

373 x 171 x h 226 cm

10,5 kW max

230 Vac 1 N 50-60 Hz

400 Vac 3 N 50-60 Hz

Su misura

Custom size

## Logica SH

Design: ————— Talocci Design

Tutta l'eleganza del sistema Logica in uno spazio più contenuto. Sauna e bagno turco diventano un vero progetto di design integrato con la tua casa.

- › Per la generazione del vapore è installato Aquasteam, con funzione Energy Saver e sistema automatico di lavaggio caldaia.

- › Materiali di eccezionale qualità: legno Hemlock canadese, rivestimenti in grès laminato Slimtech® da 3,5 mm, porte in vetro temperato da 8 mm.

- › Disponibile in sette finiture standard, o con cromie personalizzate.

All the elegant styling of the Logica system in a smaller space. A superbly designed sauna and steam bath, the perfect fit for your home.

- › The Aquasteam steam generator is installed with the Energy Saver function and automatic boiler-cleaning system.

- › Top quality materials: Canadian hemlock wood, tiling in 3.5 mm Slimtech® laminated grès porcelain, 8 mm toughened glass doors.

- › Available in seven standard finishes or personalised colour schemes.







## Materials

### SAND

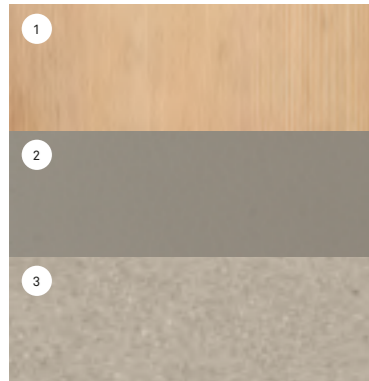

**SOFT SAND**  
Canadian Hemlock (Smooth)  
Painted Aluminium (Gray) Ral 7030  
Slimtech Soft Sand

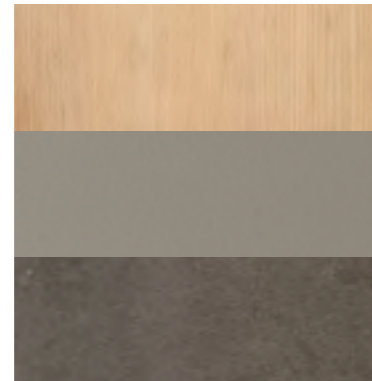

**SAND C030**  
Canadian Hemlock (Smooth)  
Painted Aluminium (Gray) Ral 7030  
Slimtech Re-Evolution C030

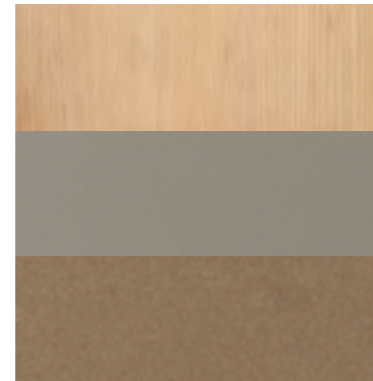

**SAND W030**  
Canadian Hemlock (Smooth)  
Painted Aluminium (Gray) Ral 7030  
Slimtech Re-Evolution W030

### CLOUD



**WHITE CLOUD**  
Canadian Hemlock (Smooth)  
Painted Aluminium (White) Ral 9010  
SA810G  
Slimtech White Cloud

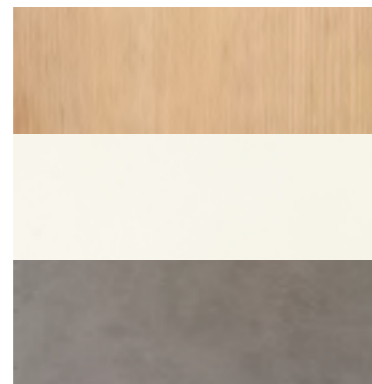

**CLOUD C020**  
Canadian Hemlock (Smooth)  
Painted Aluminium (White) Ral 9010  
SA810G  
Slimtech Re-Evolution C020

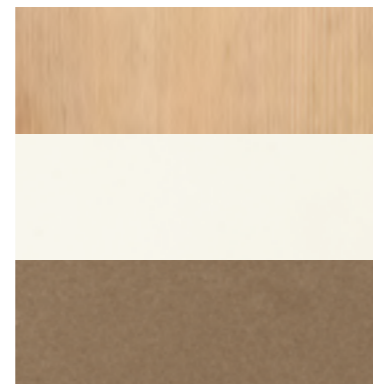

**CLOUD W030**  
Canadian Hemlock (Smooth)  
Painted Aluminium (White) Ral 9010  
SA810G  
Slimtech Re-Evolution W030

### STONE



Canadian Hemlock (Smooth)  
Painted Aluminium (Brown) YX355F  
YX355F 2525 Sablé  
Slimtech Black Stone

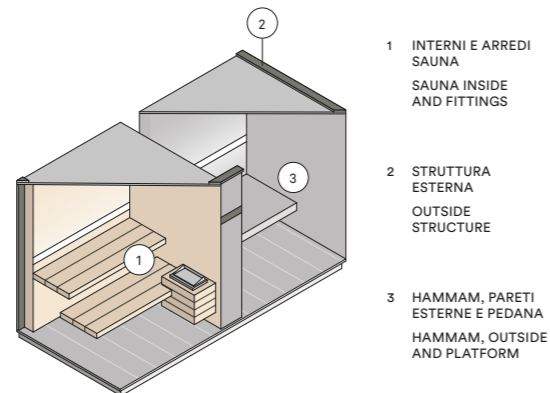

- 1 INTERNI E ARREDI  
SAUNA  
SAUNA INSIDE  
AND FITTINGS
- 2 STRUTTURA  
ESTERNA  
OUTSIDE  
STRUCTURE
- 3 HAMMAM, PARETI  
ESTERNE E PEDANA  
HAMMAM, OUTSIDE  
AND PLATFORM

## Translations

### FRANÇAIS

#### Logica SH

Toute l'élégance du système Logica en un espace plus restreint. Sauna et bain turc deviennent un véritable projet de design intégré dans votre maison.

#### Caractéristiques :

Aquasteam est installé pour la production de vapeur, avec fonction Energy Saver et système automatique de lavage de la chaudière.

Disponible en sept finitions standard, ou avec des couleurs personnalisées.  
Matériaux de qualité exceptionnelle : bois Hemlock canadien, revêtements en grès laminé Slimtech® de 3,5 mm, portes en verre trempé de 8 mm.

### DEUTSCH

#### Logica SH

Die ganze Eleganz des Systems Logica in einem kleineren Raum. Sauna und türkisches Dampfbad werden ein wahrhaftiges Designprojekt und Teil Ihres Zuhauses.

#### Beschreibung:

Für die Dampferzeugung sorgt Aquasteam mit der Funktion Energy Saver und automatischem Kesselreinigungssystem.  
Erhältlich in sieben Standardausführungen oder mit individueller Farbgestaltung.  
Materialien von außergewöhnlicher Qualität: kanadisches Hemlock-Holz; Verfließungen aus laminiertem Feinsteinzeug Slimtech®, 3,5 mm; Türen aus gehärtetem Glas, 8 mm.

### ESPAÑOL

#### Logica SH

Toda la elegancia del sistema Logica en un espacio más reducido. La sauna y el baño turco se convierten en un auténtico proyecto de diseño integrado con tu hogar.

#### Características:

Para la generación del vapor se ha instalado Aquasteam, con función de ahorro de energía y sistema automático de lavado de la caldera.

Disponible en siete acabados estándar o con colores personalizados.  
Materiales de calidad excepcional: madera Hemlock canadiense, revestimientos en gres laminado Slimtech® de 3,5 mm, puertas en vidrio templado de 8 mm.

### РУССКИЙ

#### Logica SH

Эlegantный дизайн Logica в более компактном исполнении. Сауна и парная становятся настоящим предметом дизайна, гармонирующим с интерьером Вашего дома.

#### Характеристики:

Logica SH – это оазис релаксации и здоровья, который идеально впишется в Ваш интерьер благодаря трем вариантам исполнения. Парогенератор Aquasteam с функцией энергосбережения и системой автоматической очистки нагревателя.  
Материалы превосходного качества: канадский хемлок, отделка из ламинированного керамогранита Slimtech® 3,5 мм, двери из закаленного стекла 8 мм.

### 中文

#### Logica SH

Logica 系列高度融合了优雅完美的设计。桑拿浴及土耳其浴的设计，与您的家完美结合。

#### 特点:

Logica SH 系列是家居SPA生活的理想选择，彩色光疗系统将您带入多彩的世界。  
配置Aquasteam系列蒸汽发生器，具备节能节约功能及锅炉自动清洗功能。  
优质材料：优选加拿大铁杉木，厚度为3.5mm的Slimtech®陶瓷层压板，以及经过淬火处理的厚度为8mm的钢化玻璃门板。

#### Materiali

Sauna - interno ed arredi:

- Hemlock canadese;
- Porte in vetro temperato 8 mm.

Sauna - pedana:

- Grès laminato 3,5 mm accoppiato su vetro temperato 15 mm.

Hammam - interno ed arredi:

- Grès laminato 3,5 mm;
- Porte in vetro temperato 8 mm.

Hammam - pedana:

- Grès laminato 3,5 mm accoppiato su vetro temperato 15 mm.

#### Finiture esterne

Alluminio verniciato.

Pareti esterne a vista in grès laminato 3,5 mm.

#### Componenti Sauna

Panche in legno.

Stufa con pietre.

Pannello di controllo touch.

Funzione Energy Saver automatica.

Mastellino e mestolo in legno.

Impianto elettrico canalizzato.

Illuminazione con cromoterapia a Led RGB,

- 5 colori fissi, 4 cicli dinamici e luce bianca.

#### Componenti Hammam

Aquasteam 30.

Panche in grès laminato.

Illuminazione con cromoterapia a Led RGB,

- 5 colori fissi, 4 cicli dinamici e luce bianca.

#### Componenti doccia

Miscelatore termostatico con deviatore a 3 vie.

Doccia a mano.

Soffione doccia a soffitto 42 x 42 cm, con funzioni pioggia e nebulizzazione.

#### ECC - Effe Comfort Control

Sistema che consente di gestire a distanza sauna e hammam dal proprio dispositivo, tramite l'App Effegibi Experience. Disponibile su iOS.

#### Materials

Sauna - inside and fittings:

- Canadian Hemlock;
- Doors in 8 mm tempered glass.

Sauna - platform:

- 3.5 mm laminated grès porcelain fitted to 15 mm toughened glass.

Hammam - inside and fittings:

- 3.5 mm laminated grès porcelain;
- Doors in 8 mm tempered glass.

Hammam - platform:

- 3.5 mm laminated grès porcelain fitted to 15 mm toughened glass.

#### Outside wall finish

Painted aluminium.

Outside wall finish laminated grès porcelain 3.5 mm.

#### Sauna includes

Wooden benches.

Heater with stones.

Touch control panel.

Automatic Energy Saving function.

Bucket and wooden ladle.

Electrical system with protected cable ducts.

Lighting system with Led RGB colour therapy, 5 fixed colours, 4 dynamic cycles and white light.

#### Hammam includes

Aquasteam 30.

Unglazed porcelain tile benches.

Lighting system with Led RGB colour therapy,

- 5 fixed colours, 4 dynamic cycles and white light.

#### Shower includes

Thermostatic mixer with 3-way diverter.

Hand-held shower head.

42 x 42 cm ceiling-mounted shower head with rain and nebuliser functions.

#### ECC - Effe Comfort Control

System that remotely controls the sauna and the steam bath from your device, using the Effegibi Experience app. Available on iOS.

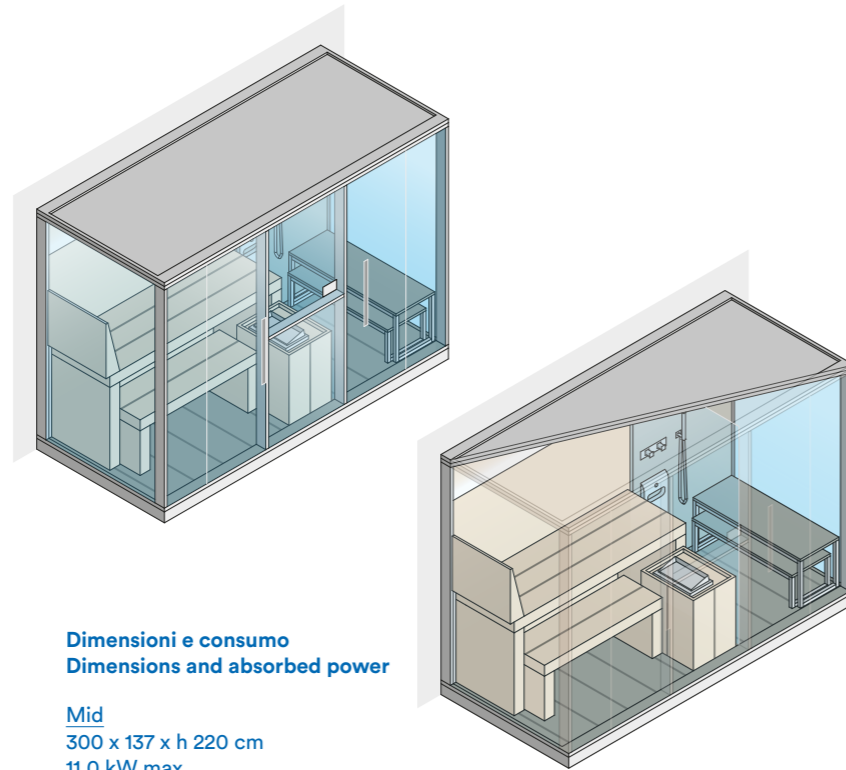

#### Dimensioni e consumo Dimensions and absorbed power

##### Mid

300 x 137 x h 220 cm

11,0 kW max

230 Vac 1 N 50-60 Hz

400 Vac 3 N 50-60 Hz

Su misura

Custom size

## Mid

Design: \_\_\_\_\_ Talocci Design

In soli 3 metri Mid abbina sauna e hammam in un unico e prezioso oggetto di design. La trasparenza fra gli ambienti rende l'impatto estetico leggero e piacevole.

- › Aquasteam per la generazione del vapore: il meglio della tecnologia per il bagno turco.
- › Materiali di eccezionale qualità: legno Hemlock canadese, rivestimenti in grès laminato Slimtech® da 3,5 mm, porte in vetro temperato da 8 mm.
- › Disponibile in sette finiture standard, o con cromie personalizzate.
- › Spazio doccia comodo e funzionale, con miscelatore termostatico, doccia a mano e soffione doccia a soffitto 42x42 cm con funzioni pioggia e nebulizzazione.

Mid combines a sauna and a Hammam in a space of just 3 metres, a triumph of design. The clear glass dividing the two environments creates a pleasant light and airy look.

- › The Aquasteam steam generator runs on the best technology for the steam bath.
- › Top quality materials: Canadian hemlock wood, tiling in 3.5 mm Slimtech® laminated grès porcelain, 8mm toughened glass doors.
- › Available in seven standard finishes or personalised colour schemes.
- › Comfortable, practical shower space, with thermostatic mixer tap, hand-held and ceiling-mounted (42x42 cm) shower head, with rain and nebuliser functions.





Sauna: natural Canadian hemlock.



Mid / sauna + hammam + shower /





The bench seats are made of glass coupled with 3.5mm Slimtech® laminated grès porcelain, a material that is extremely resistant to temperature fluctuations and very pleasant to the touch.

Sauna:  
natural Canadian hemlock.



## Materials

### SAND

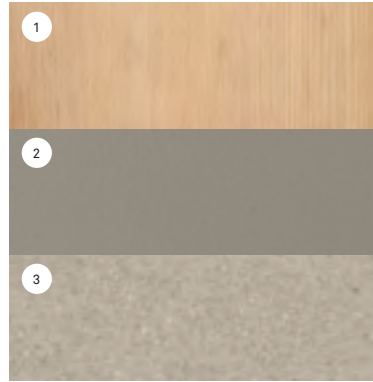

**SOFT SAND**  
Canadian Hemlock (Smooth)  
Painted Aluminium (Gray) Ral 7030  
Slimtech Soft Sand



**SAND C030**  
Canadian Hemlock (Smooth)  
Painted Aluminium (Gray) Ral 7030  
Slimtech Re-Evolution C030

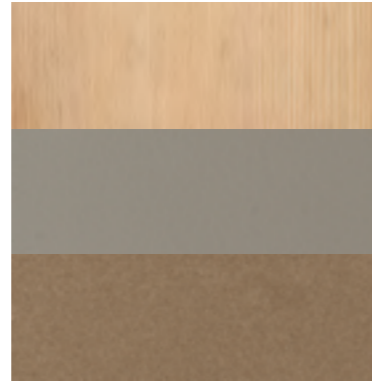

**SAND W030**  
Canadian Hemlock (Smooth)  
Painted Aluminium (Gray) Ral 7030  
Slimtech Re-Evolution W030

### CLOUD



**WHITE CLOUD**  
Canadian Hemlock (Smooth)  
Painted Aluminium (White) Ral 9010  
SA810G  
Slimtech White Cloud

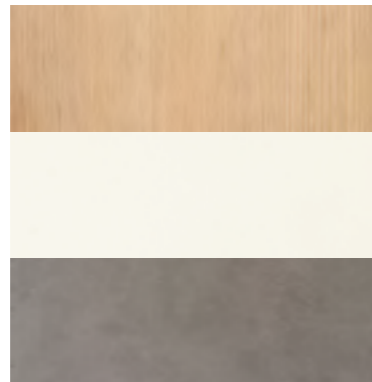

**CLOUD C020**  
Canadian Hemlock (Smooth)  
Painted Aluminium (White) Ral 9010  
SA810G  
Slimtech Re-Evolution C020

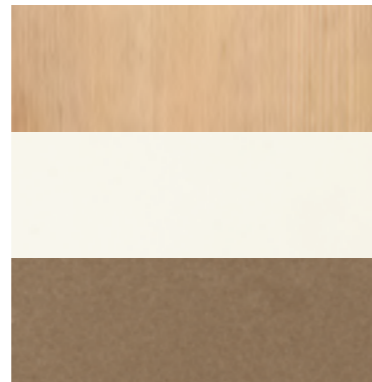

**CLOUD W030**  
Canadian Hemlock (Smooth)  
Painted Aluminium (White) Ral 9010  
SA810G  
Slimtech Re-Evolution W030

### STONE



Canadian Hemlock (Smooth)  
Painted Aluminium (Brown) YX355F  
YX355F 2525 Sablé  
Slimtech Black Stone

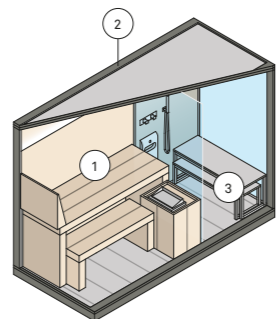

- 1 INTERNI E ARREDI  
SAUNA  
SAUNA INSIDE  
AND FITTINGS
- 2 STRUTTURA  
ESTERNA  
OUTSIDE  
STRUCTURE
- 3 HAMMAM  
E PEDANA  
HAMMAM  
AND PLATFORM

## Translations

### FRANÇAIS

#### Mid

En 3 mètres seulement, Mid unit le sauna et le hammam en un seul objet de design précieux. La transparence entre les espaces rend l'impact esthétique léger et agréable.

#### Caractéristiques :

Aquasteam pour la production de vapeur : le meilleur de la technologie pour le bain turc.  
Matériaux de qualité exceptionnelle : bois Hemlock canadien, revêtements en grès laminé Slimtech® de 3,5 mm, portes en verre trempé de 8 mm. Disponible en sept finitions standard, ou avec des couleurs personnalisées.  
Espace douche pratique et fonctionnel, avec mitigeur thermostatique, douche à main et pomme de douche au plafond 42x42 cm avec fonctions pluie et nébulisation.

### DEUTSCH

#### Mid

Mid vereint in nur 3 Metern Sauna und Hamam in einem einzigen kostbaren Design-Objekt. Dank der Transparenz zwischen den Bereichen ist dieses Produkt leicht und einladend.

#### Beschreibung:

Aquasteam für die Dampferzeugung: das Beste der Technologie für das türkische Dampfbad.  
Materialien von außergewöhnlicher Qualität: kanadisches Hemlock-Holz; Verfließungen aus laminiertem Feinsteinzeug Slimtech®, 3,5 mm; Türen aus gehärtetem Glas, 8 mm.  
Erhältlich in sieben Standardausführungen oder mit individueller Farbgestaltung.  
Bequemer und praktischer Duschbereich, mit Thermostاتمischer, Handbrause und Deckenbrause 42x42 cm mit den Funktionen Regen und Nebel.

### ESPAÑOL

#### Mid

Mid combina, en sólo 3 metros, sauna y hammam en un único y precioso objeto de diseño. La transparencia entre los ambientes hace que el impacto estético sea ligero y agradable.

#### Características:

Aquasteam para la generación del vapor: lo mejor de la tecnología para el baño turco.  
Materiales de calidad excepcional: madera Hemlock canadiense, revestimientos en Gres laminado Slimtech® de 3,5 mm, puertas en vidrio templado de 8 mm.  
Disponible en siete acabados estándar o con colores personalizados.  
Espacio ducha cómodo y funcional, con mezclador termostático, ducha manual y alcachofa para ducha de techo de 42x42 cm con funciones lluvia y nebulización.

### РУССКИЙ

#### Mid

Модель Mid объединяет сауну и хаммам, образуя элегантный предмет дизайна длиной всего 3 метра. Благодаря прозрачным стеклянным стенам конструкция отличается легкостью и приятной эстетикой.

#### Характеристики:

Парогенератор Aquasteam: самое лучшее оборудование для турецкой бани.  
Материалы превосходного качества: канадский хемлок, отделка из ламинированного керамогранита Slimtech® 3,5 мм, двери из закаленного стекла 8 мм.  
Три стандартных варианта отделки или отделка по индивидуальному заказу.  
Удобное и функциональное душевое пространство, смеситель с термостатом, ручной душ и душевая лейка потолочной фиксации 42x42 см с имитацией дождя и тумана.

#### Materiali sauna

Interno e arredi:

Hemlock Canadese;

Porte in vetro temperato 8 mm  
accoppiato su vetro temperato 15 mm.

#### Materiali doccia

Pedana: Grès laminato 3,5 mm  
accoppiato su vetro temperato 15 mm.

#### Finiture

Alluminio veniciato.

Pareti esterne a vista grès laminato 3,5 mm.

#### Caratteristiche/Componenti Sauna

Panche in legno.

Stufa con pietre.

Pannello di controllo touch.

Funzione Energy Saver automatica.

Mastellino integrato nella panca inferiore.

Mestolo in legno.

Clessidra.

Impianto elettrico canalizzato.

Illuminazione con cromoterapia a Led RGB,

5 colori fissi, 4 cicli dinamici e luce bianca.

#### Caratteristiche/Componenti Doccia

Miscelatore con cartuccia progressiva e deviatore.

Soffione doccia a soffitto con anticalcare.

Doccia a mano.

#### ECC - Effe Comfort Control

Sistema che consente di gestire a distanza  
la sauna dal proprio dispositivo, tramite  
l'App Effegibi Experience. Disponibile su iOS.

#### Sauna materials

Inside and fittings: Canadian Hemlock.

Doors in 8 mm tempered glass.

#### Shower materials

Platform: 3.5 mm laminated grès porcelain

fitted to 15 mm toughened glass.

#### Sauna features/components

Wooden benches.

Heater with stones.

Touch control panel.

Automatic energy saving function.

Bucket built into the lower bench.

Wooden ladle.

Hourglass.

Electrical system with protected cable ducts.

Lighting system with Led RGB colour therapy,

5 fixed colours, 4 dynamic cycles and white light.

Audio set-up with built-in speakers.

And ess-effegibi sound system.

#### Shower features/components

Mixer tap with flow regulator and diverter.

Ceiling mounted anti-scale shower head.

Hand-held shower head.

#### ECC - Effe Comfort Control

System that remotely controls the sauna from  
your device, using the Effegibi Experience app.  
Available on iOS.

#### Dimensioni e consumo

Dimensions and absorbed power

#### Logica S

214 x 250 x h 226 cm

6,0 kW max

230 Vac 1N 50-60 Hz

400 Vac 3N 50-60 Hz

Su misura

Custom size

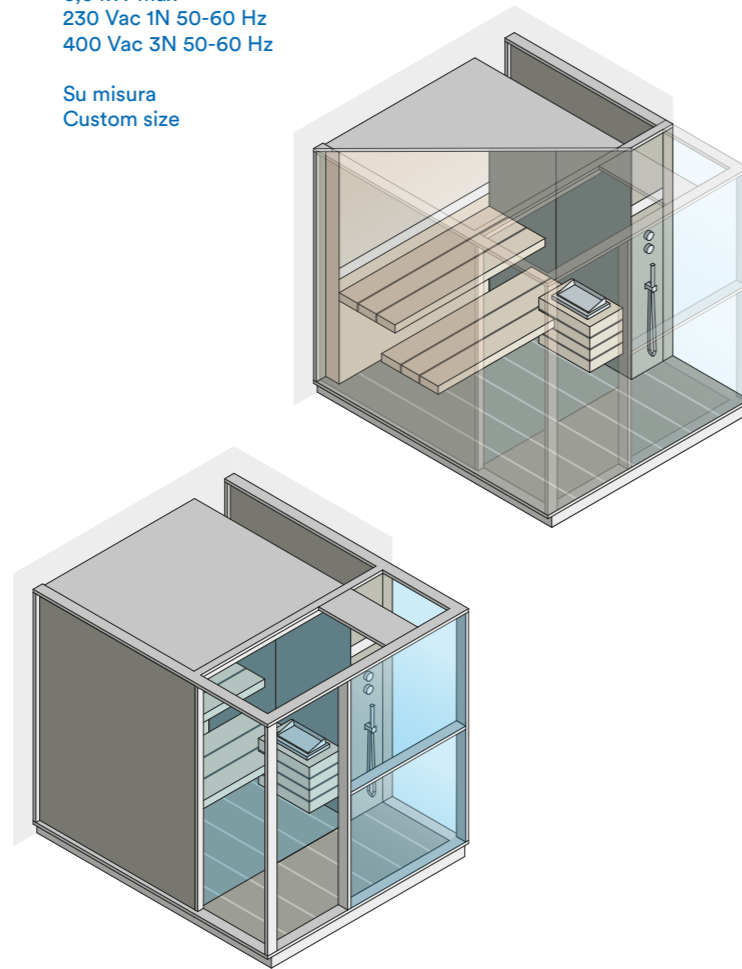



## Logica S

Design: \_\_\_\_\_ Talocci Design

Il rito della sauna si completa con la zona doccia, accuratamente progettata nel pieno rispetto della tradizione finlandese.

› Tutta la zona sauna è rivestita in legno di Hemlock canadese, il materiale più pregiato utilizzato per le saune finlandesi.

› La struttura esterna alla sauna è disponibile in sette finiture standard, o con cromie personalizzate.

The sauna is completed with a shower area, carefully designed to be faithful to the Finnish tradition.

› The entire sauna area is clad in Canadian hemlock wood, the most highly prized material for Finnish saunas.

› The outside of the sauna is available in seven standard finishes or with personalised colour schemes.



## Materials

### SAND

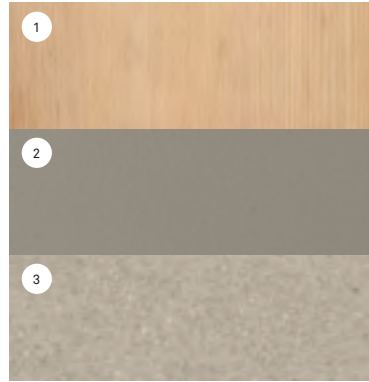

**SOFT SAND**  
Canadian Hemlock (Smooth)  
Painted Aluminium (Gray) Ral 7030  
Slimtech Soft Sand



**SAND C030**  
Canadian Hemlock (Smooth)  
Painted Aluminium (Gray) Ral 7030  
Slimtech Re-Evolution C030

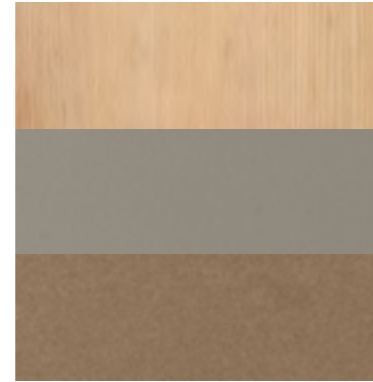

**SAND W030**  
Canadian Hemlock (Smooth)  
Painted Aluminium (Gray) Ral 7030  
Slimtech Re-Evolution W030

### CLOUD

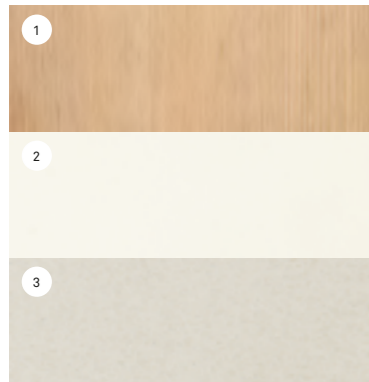

**WHITE CLOUD**  
Canadian Hemlock (Smooth)  
Painted Aluminium (White) Ral 9010  
SA810G  
Slimtech White Cloud

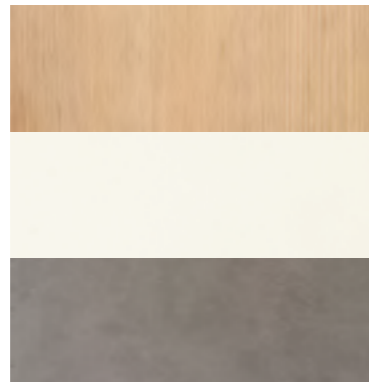

**CLOUD C020**  
Canadian Hemlock (Smooth)  
Painted Aluminium (White) Ral 9010  
SA810G  
Slimtech Re-Evolution C020

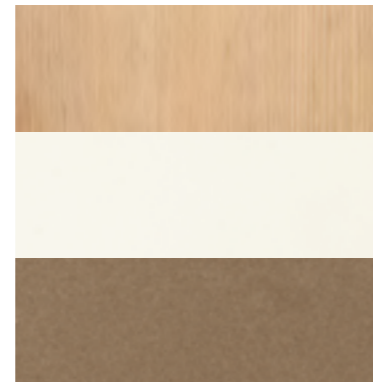

**CLOUD W030**  
Canadian Hemlock (Smooth)  
Painted Aluminium (White) Ral 9010  
SA810G  
Slimtech Re-Evolution W030

### STONE

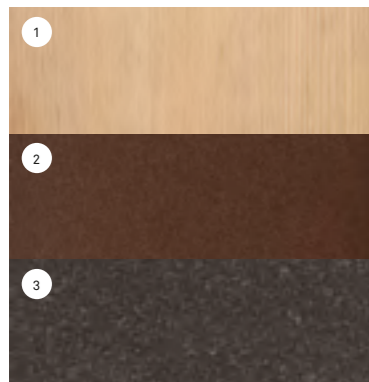

Canadian Hemlock (Smooth)  
Painted Aluminium (Brown) YX355F  
YX355F 2525 Sablé  
Slimtech Black Stone

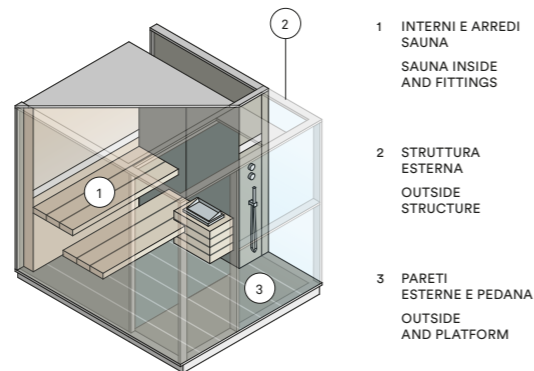

- 1 INTERNI E ARREDI  
SAUNA  
SAUNA INSIDE  
AND FITTINGS
- 2 STRUTTURA  
ESTERNA  
OUTSIDE  
STRUCTURE
- 3 PARETI  
ESTERNE E PEDANA  
OUTSIDE  
AND PLATFORM

## Translations

### FRANÇAIS

#### Logica S

Le rite du sauna se complète avec la zone douche, spécialement conçue dans le plein respect de la tradition finlandaise.

#### Caractéristiques :

Toute la zone sauna est revêtue en bois de Hemlock canadien, le matériau le plus précieux utilisé pour les saunas finlandais

La structure externe au sauna est disponible en trois finitions standard, ou avec des couleurs personnalisées

### DEUTSCH

#### Logica S

Das Saunaritual wird durch einen Duschbereich ergänzt, der ganz nach der finnischen Tradition konzipiert ist.

#### Beschreibung:

Der gesamte Saunabereich ist mit kanadischem Hemlock-Holz ausgekleidet, dem hochwertigsten Material für finnische Saunen

Der Außenbau der Sauna ist in drei Standardausführungen oder mit individueller Farbgestaltung erhältlich.

### ESPAÑOL

#### Logica S

El ritual de la sauna se completa con la zona ducha, proyectada con precisión para respetar plenamente la tradición finlandesa.

#### Características:

Toda la zona sauna está revestida con madera de Hemlock canadiense, el material de mayor calidad utilizado para las saunas finlandesas

La estructura externa de la sauna se encuentra disponible en tres acabados estándar o con colores personalizados.

### РУССКИЙ

#### Logica S

Ритуал очищения в сауне завершается в душевой кабине, созданной в лучших финских традициях.

#### Характеристики:

Весь модуль сауны отделан канадским хемлоком – отборной древесиной, используемой в традиционных финских саунах.

Три стандартных варианта отделки или отделка по индивидуальному заказу.

### 中文

#### Logica S

淋浴空间的桑拿浴，完全准确地遵照芬兰传统桑拿浴进行设计。

#### 特点:

整个桑拿空间均采用优质加拿大铁杉木，是用于芬兰桑拿浴最珍贵的木材。桑拿浴可提供三种标准的外观效果，或进行个人定制。

#### Materiali

Interno e arredi:

Hemlock Canadese.

Porte in vetro temperato 8 mm.

Pedana: Grès laminato 3,5 mm accoppiato  
su vetro temperato 15 mm.

#### Finiture

Alluminio verniciato.

Pareti esterne a vista grès

Laminato 3,5 mm.

#### Caratteristiche/Componenti

Panche in legno.

Stufa con pietre.

Pannello di controllo touch.

Funzione energy saver automatica.

Mastellino integrato nella panca inferiore.

Mestolo in legno.

Clessidra.

Impianto elettrico canalizzato.

Illuminazione con cromoterapia a Led RGB,  
5 colori fissi, 4 cicli dinamici e luce bianca.

#### ECC - Effe Comfort Control

Sistema che consente di gestire a distanza

la sauna dal proprio dispositivo, tramite

l'App Effegibi Experience. Disponibile su iOS.

#### Materials

Inside and fittings: Canadian Hemlock.

Doors in 8 mm tempered glass.

Platform: 3.5 mm laminated grès porcelain  
fitted to 15 mm toughened glass.

#### Finishes

Painted aluminium.

Outside wall finish laminated grès porcelain  
3.5 mm.

#### Features/components:

Wooden benches.

Heater with stones.

Touch control panel.

Automatic energy saving function.

Bucket built into the lower bench.

Wooden ladle.

Hourglass.

Electrical system with protected cable ducts

Lighting system with Led RGB colour therapy,  
5 fixed colours and 4 dynamic cycles  
and white light.

#### ECC - Effe Comfort Control

System that remotely controls the sauna from

your device, using the Effegibi Experience app.

Available on iOS.

#### Dimensioni e consumo

#### Dimensions and absorbed power

#### One S

214 x 171 x h 226 cm

6,0 kW max

230 Vac 1N 50-60 Hz

400 Vac 3N 50-60 Hz

Su misura

Custom size

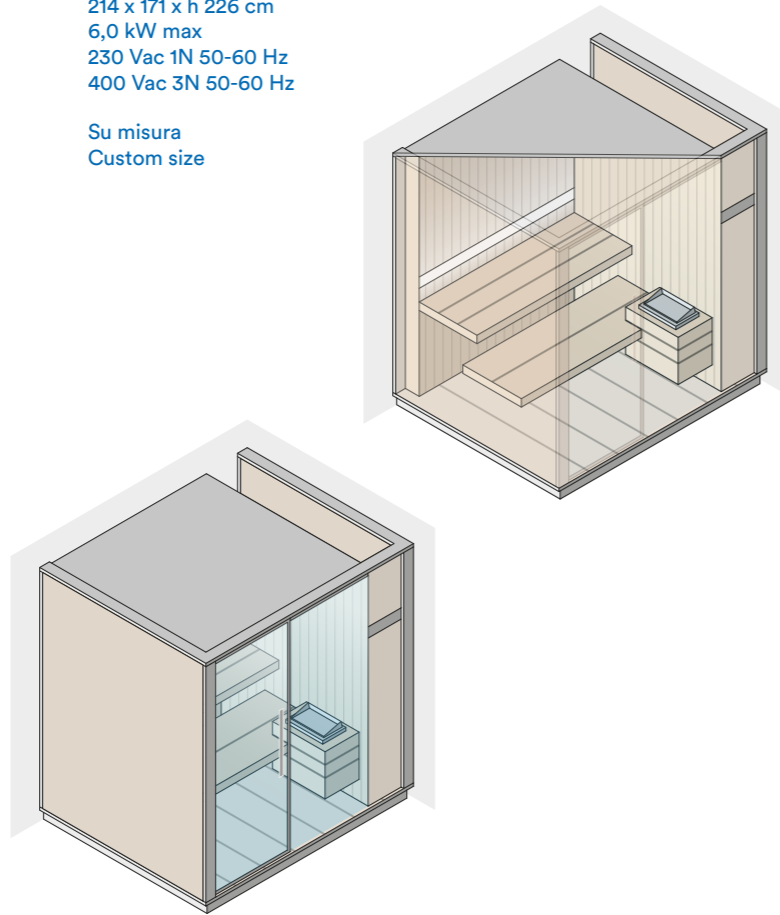

## One S

Design: \_\_\_\_\_ Talocci Design

One S è concepita per essere estremamente pratica e realizzata con materiali di eccezionale qualità: interni e arredi in Hemlock canadese, molto resistente nel tempo. Abbinata con One H, offre grande versatilità nelle applicazioni in centri benessere, palestre o in casa.

- › Disponibili in sette finiture standard, o con cromie personalizzate.
- › One H utilizza Aquasteam 45 per la generazione del vapore, per un controllo totale di densità e igiene.
- › Grande versatilità nelle applicazioni, in centri benessere, palestre o in casa.

One S has been designed with practicality in mind and is made from top-quality materials: the interiors and fittings are in Canadian hemlock which is very long-lasting. Can be combined with One H, making it highly versatile and ideal for spas, gyms or private homes.

- › Available in seven standard finishes or with a personalised colour scheme.
- › One H uses an Aquasteam 45 steam generator, for total steam density and hygiene control.
- › Extremely versatile, ideal for location in a spa, gym or a private home.







Lighting system with Led RGB colour therapy, 5 fixed colours and 4 dynamic cycles and white light.

One S / sauna /

136

One S / sauna /

137

## Materials

### SAND

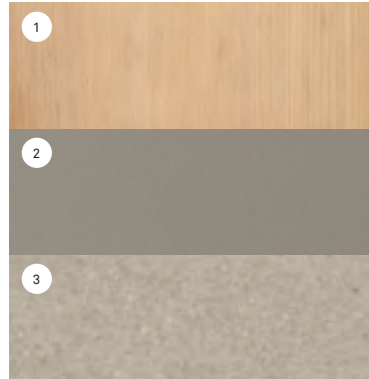

**SOFT SAND**  
Canadian Hemlock (Smooth)  
Painted Aluminium (Gray) Ral 7030  
Slimtech Soft Sand

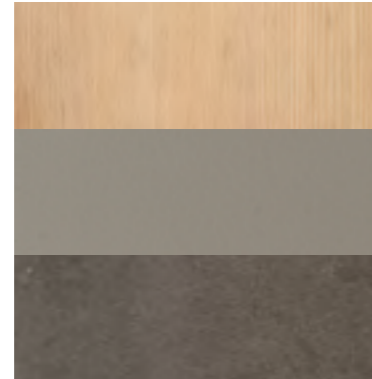

**SAND C030**  
Canadian Hemlock (Smooth)  
Painted Aluminium (Gray) Ral 7030  
Slimtech Re-Evolution C030

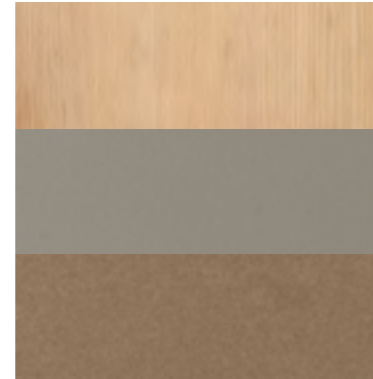

**SAND W030**  
Canadian Hemlock (Smooth)  
Painted Aluminium (Gray) Ral 7030  
Slimtech Re-Evolution W030

### CLOUD

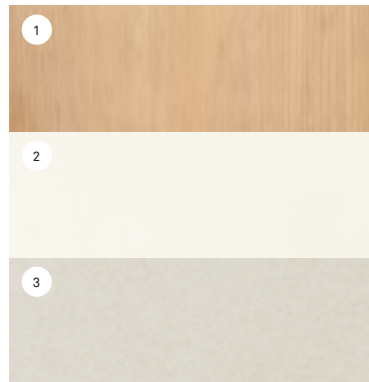

**WHITE CLOUD**  
Canadian Hemlock (Smooth)  
Painted Aluminium (White) Ral 9010  
SA810G  
Slimtech White Cloud

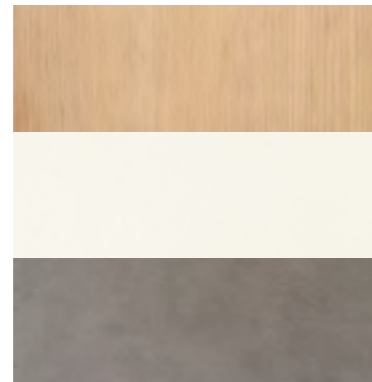

**CLOUD C020**  
Canadian Hemlock (Smooth)  
Painted Aluminium (White) Ral 9010  
SA810G  
Slimtech Re-Evolution C020

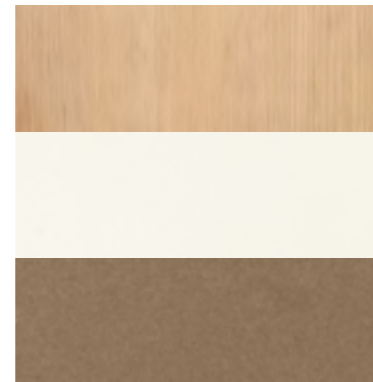

**CLOUD W030**  
Canadian Hemlock (Smooth)  
Painted Aluminium (White) Ral 9010  
SA810G  
Slimtech Re-Evolution W030

### STONE

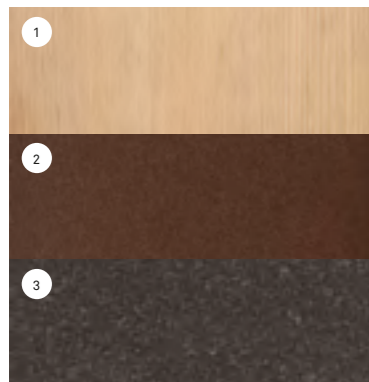

Canadian Hemlock (Smooth)  
Painted Aluminium (Brown) YX355F  
YX355F 2525 Sablé  
Slimtech Black Stone

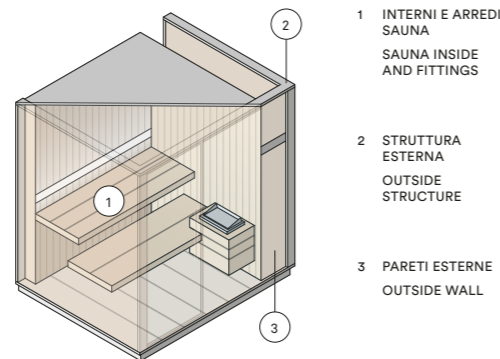

- 1 INTERNI E ARREDI  
SAUNA  
SAUNA INSIDE  
AND FITTINGS
- 2 STRUTTURA  
ESTERNA  
OUTSIDE  
STRUCTURE
- 3 PARETI ESTERNE  
OUTSIDE WALL

## Translations

### FRANÇAIS

**One S**  
One S est conçu pour être extrêmement pratique et fabriqué avec des matériaux de qualité exceptionnelle : intérieurs et mobilier en Hemlock canadien, très résistant dans le temps. Combiné avec One H, il offre de nombreuses applications possibles, dans des centres de bien-être, salles de gym ou à la maison.

#### Caractéristiques :

One H utilise Aquasteam 45 pour la production de vapeur, pour un contrôle total de la densité et de l'hygiène. Disponible en sept finitions standard, ou avec des couleurs personnalisées. De nombreuses applications possibles, dans des centres de bien-être, salles de gym ou à la maison.

### ESPAÑOL

**One S**  
One S se ha pensado para ser extremadamente práctica y se ha realizado con materiales de gran calidad: interiores y mobiliario en Hemlock canadiense, muy resistente al tiempo. Combinada con One H, ofrece gran versatilidad en las aplicaciones, en centros de bienestar, gimnasios o en casa.

#### Características:

One H utiliza Aquasteam 45 para la generación del vapor, para un control total de densidad e higiene. Disponibles en siete acabados estándar o con colores personalizados. Gran versatilidad en las aplicaciones, en centros de bienestar, gimnasios o en casa.

### 中文

**One S**  
One S 的设计以实用为宗旨，采用顶级材料打造：内饰和配件均为经久耐用的加拿大铁杉木。可以与 One H 搭配，形成极为全面的功能组合，非常适合水疗馆、健身馆，或私人住宅。

#### 特点:

One H 湿蒸土耳其浴使用 Aquasteam 45 型蒸汽发生器，提供高浓度且质地清洁的优质蒸汽。三种标准表面效果可供选择，或进行个性化颜色定制。适用于多种类型空间，比如 SPA 中心、健身房或者自己家中。

### DEUTSCH

**One S**  
One S ist äußerst praktisch und wird aus Materialien von außergewöhnlicher Qualität gefertigt. Die Innenausstattung und Möbel sind aus sehr langlebigem kanadischen Hemlock. Kombiniert mit One H bietet sie eine große Anwendungsvielseitigkeit in Wellnesscentern, Fitnessstudios oder zu Hause.

#### Beschreibung:

One H nutzt Aquasteam 45 für die Dampferzeugung, für eine absolute Dichte und Hygienekontrolle. Erhältlich in sieben Standardausführungen oder mit individueller Farbgestaltung. Große Vielseitigkeit in der Anwendung für Wellnesscenter, Fitnesscenter oder zuhause.

### РУССКИЙ

**One S**  
Сауна One S изготовлена из материалов высочайшего качества: внутренняя обшивка и предметы интерьера выполнены из канадского хемлока – древесины, отличающейся особой практичностью и долговечностью. В сочетании с хаммамом One H эта сауна позволяет создавать комплексные спа-решения в салонах, фитнес-центрах или в домашних условиях.

#### Характеристики:

One H оснащен парогенератором Aquasteam 45, который позволяет максимально контролировать подачу пара и поддерживать высокий уровень гигиены. Три стандартных варианта отделки или отделка по индивидуальному заказу. Универсальность применения: в спа-салонах, фитнес-центрах или в домашних условиях.

#### Materiali hammam

Interno e arredi:

- grès laminato 3,5 mm.
- Porte in vetro temperato 8 mm.
- Pedana hammam e doccia: grès laminato 3,5 mm accoppiato su vetro temperato 15 mm.

#### Finiture

Alluminio verniciato.  
Parete esterne a vista grès laminato 3,5 mm.

#### Caratteristiche/Componenti hammam

Aquasteam 45.  
Panche in grès laminato.  
Illuminazione con cromoterapia a Led RGB,  
5 colori fissi, 4 cicli dinamici e luce bianca.

#### Caratteristiche/Componenti doccia

Miscelatore con cartuccia progressiva e deviatore.  
Soffione doccia a soffitto con anticalcare.  
Doccia a mano.

#### ECC - Effe Comfort Control

Sistema che consente di gestire a distanza  
il bagno turco dal proprio dispositivo, tramite  
l'App Effegibi Experience. Disponibile su iOS.

#### Hamмам materials

Inside and fitting:

- 3.5 mm laminated grès porcelain.
- Doors in 8 mm tempered glass.
- Hamмам and shower platform: 3.5 mm laminated grès porcelain fitted to 15 mm toughened glass.

#### Finishes

Painted aluminium.  
Outside wall finish laminated  
Grès porcelain 3.5 mm.

#### Hamмам features/components

Aquasteam 45.  
Unglazed porcelain tile benches.  
Lighting system with Led RGB colour therapy,  
5 fixed colours, 4 dynamic cycles and white light.

#### Shower features/components

Mixer tap with flow regulator and diverter.  
Ceiling mounted anti-scale shower head.  
Hand-held shower head.

#### ECC - Effe Comfort Control

System that remotely controls the steam bath  
from your device, using the Effegibi Experience  
app. Available on iOS.

#### Dimensioni e consumo

#### Dimensions and absorbed power

#### Logica H

214 x 250 x h 226 cm  
4,5 kW max  
230 Vac 1N 50-60 Hz  
400 Vac 3N 50-60 Hz

Su misura  
Custom size

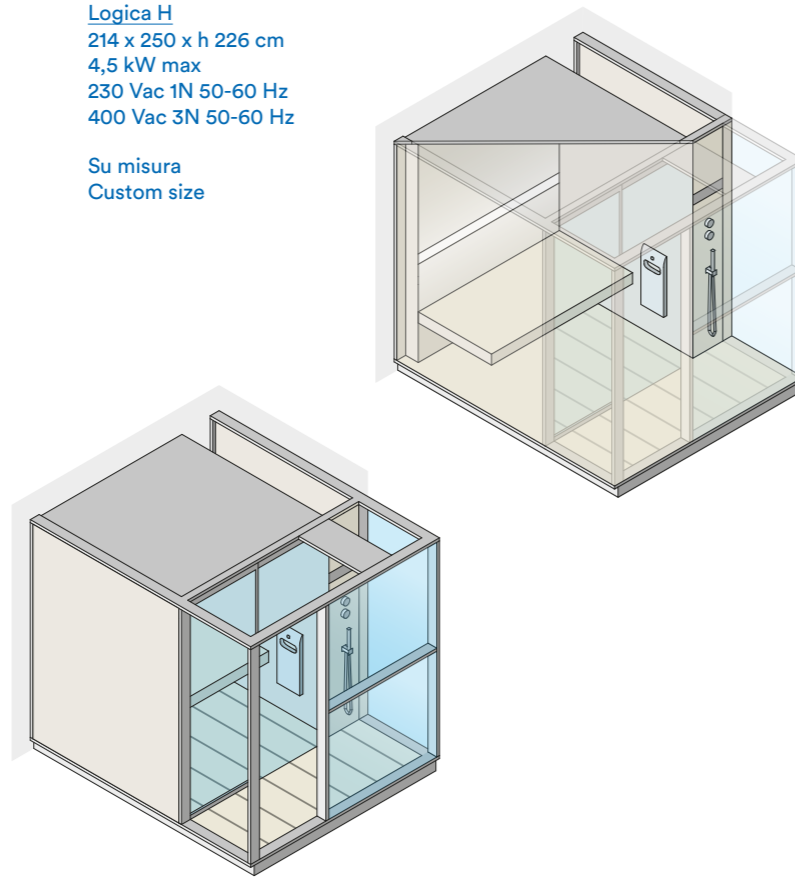



## Logica H

Design: \_\_\_\_\_ Talocci Design

Logica H abbina la magia del bagno turco allo spazio doccia in un prodotto unico che diventa un vero angolo di benessere quotidiano.

- › Aquasteam, la migliore tecnologia disponibile per la generazione del vapore.
- › Materiali di eccezionale qualità: rivestimenti in grès laminato Slimtech® da 3,5 mm, porte in vetro temperato da 8 mm.
- › Disponibile in sette finiture standard, o con cromie personalizzate.

Logica H combines the magic of the steam bath with a shower space in a single product that will become an amazing corner of day-to-day wellbeing.

- › Aquasteam, the best steam generation technology.
- › Top quality materials: tiling in 3.5mm Slimtech® laminated grès porcelain, 8mm toughened glass doors.
- › Available in seven standard finishes or with personalised colour schemes.



## Materials

### SAND

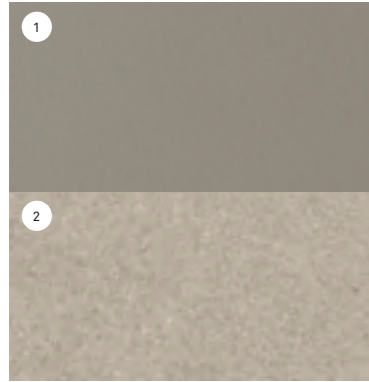

**SOFT SAND**  
Painted Aluminium (Gray) Ral 7030  
Slimtech Soft Sand

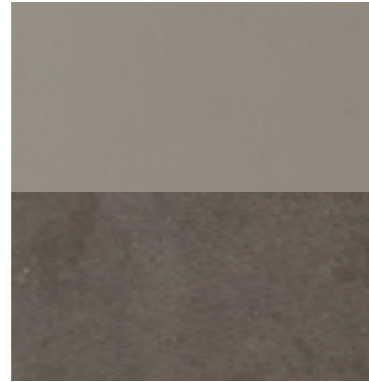

**SAND C030**  
Painted Aluminium (Gray) Ral 7030  
Slimtech Re-Evolution C030

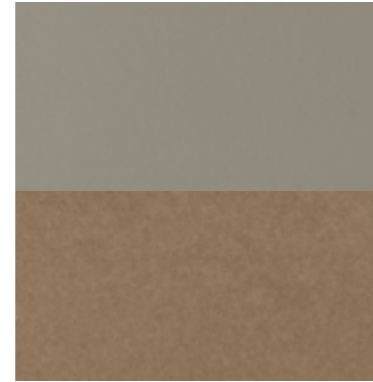

**SAND W030**  
Painted Aluminium (Gray) Ral 7030  
Slimtech Re-Evolution W030

### CLOUD



**WHITE CLOUD**  
Painted Aluminium (White)  
Ral 9010 SA810G  
Slimtech White Cloud

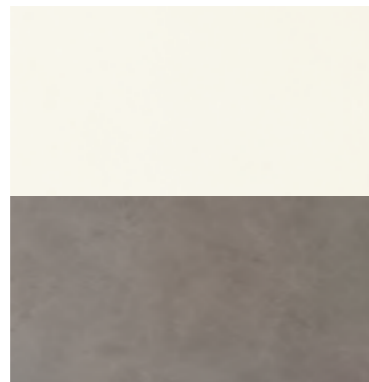

**CLOUD C020**  
Painted Aluminium (White)  
Ral 9010 SA810G  
Slimtech Re-Evolution C020

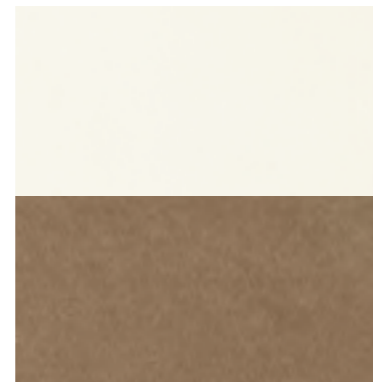

**CLOUD W030**  
Painted Aluminium (White)  
Ral 9010 SA810G  
Slimtech Re-Evolution W030

### STONE

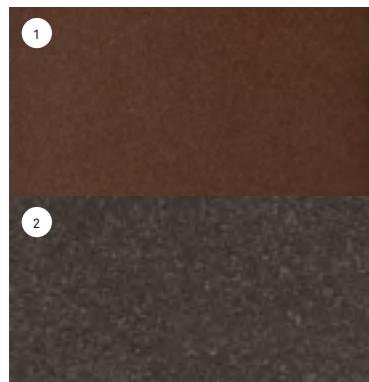

Painted Aluminium (Brown)  
YX355F 2525 Sablé  
Slimtech Black Stone

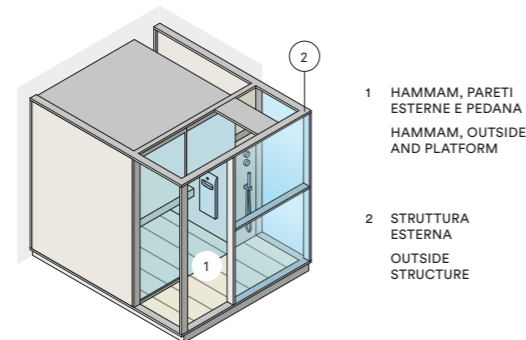

- 1 HAMMAM, PARETI ESTERNE E PEDANA  
HAMMAM, OUTSIDE AND PLATFORM
- 2 STRUTTURA ESTERNA  
OUTSIDE STRUCTURE

## Translations

### FRANÇAIS

**Logica H**  
Logica H conjugue la magie du bain turc à l'espace douche en un produit unique qui devient un véritable coin de bien-être quotidien.

Caractéristiques :

Aquasteam, la meilleure technologie disponible pour la production de vapeur.

Matériaux de qualité exceptionnelle : revêtements en grès laminé Slimtech® de 3,5 mm, portes en verre trempé de 8 mm.

Disponible en sept finitions standard, ou avec des couleurs personnalisées.

### ESPAÑOL

**Logica H**  
Logica H combina la magia del baño turco con el espacio ducha en un producto único que se convierte en un auténtico remanso de bienestar diario.

Características:

Aquasteam, la mejor tecnología disponible para la generación del vapor. Materiales de calidad excepcional: revestimientos en grés laminado Slimtech® de 3,5 mm, puertas en vidrio templado de 8 mm.

Disponible en siete acabados estándar o con colores personalizados.

### 中文

**Logica H**  
Logica 湿蒸系列神奇的将土耳其浴与淋浴空间合为一体，使之成为我们日常生活中的健康空间。

特点:

使用高端技术Aquasteam系列蒸汽发生器

优质材料: 土耳其浴系列使用厚度为3.5mm的Slimtech®超薄陶瓷层压板, 密封门则采用经过淬火处理的8mm厚钢化玻璃。

三种标准表面效果可供选择, 或进行个性颜色定制。

### DEUTSCH

**Logica H**  
Logica H kombiniert die Magie des türkischen Dampfbads mit dem Duschbereich in einem einzigen Produkt - eine wahrhafte Wellnessecke für jeden Tag.

Beschreibung:

Aquasteam, die beste Technologie für die Dampferzeugung.

Materialien von außergewöhnlicher Qualität: Verfließungen aus laminiertem Feinsteinzeug Slimtech®, 3,5 mm; Türen aus gehärtetem Glas, 8 mm.

Erhältlich in sieben Standardausführungen oder mit individueller Farbgestaltung.

### РУССКИЙ

**Logica H**  
Logica H объединяет турецкую парную и душевую кабину в едином пространстве для ежедневной релаксации и здоровья.

Характеристики:

Высокотехнологичный парогенератор Aquasteam – самое лучшее оборудование для турецкой бани.

Материалы превосходного качества: отделка из ламинированного керамогранита Slimtech® 3,5 мм, двери из закаленного стекла 8 мм.

Три стандартных варианта отделки или отделка по индивидуальному заказу.

#### Materiali

Interno e arredi:

- Grès laminato 3,5 mm;
- Porte in vetro temperato 8 mm.

Pedana: grès laminato 3,5 mm accoppiato su vetro temperato 15 mm.

#### Finiture esterne

Alluminio verniciato.

Pareti esterne a vista in grès laminato 3,5 mm.

#### Caratteristiche/Componenti

Aquasteam 45.

Panche in grès laminato.

Illuminazione con cromoterapia a Led RGB, 5 colori fissi, 4 cicli dinamici e luce bianca.

Predisposizione audio con altoparlanti incorporati e ESS - Effe Sound System.

#### ECC - Effe Comfort Control

Sistema che consente di gestire a distanza

il bagno turco dal proprio dispositivo, tramite l'App Effegibi Experience. Disponibile su iOS.

#### Materials

Inside and fitting:

- 3.5 laminated grès porcelain;
- Doors in 8 mm tempered glass.

Platform: 3.5 mm laminated grès porcelain fitted to 15 mm toughened glass.

#### Outside wall finish

Painted aluminium;

Outside wall finish laminated grès porcelain 3.5 mm.

#### Features/Components

Aquasteam 45.

Unglazed porcelain tile benches.

Lighting system with Led RGB colour therapy,

5 fixed colours, 4 dynamic cycles and white light.

Audio set-up with built-in speakers and ESS - Effe Sound System.

#### ECC - Effe Comfort Control

System that remotely controls the steam bath

from your device, using the Effegibi Experience app. Available on iOS.

#### Dimensioni e consumo

#### Dimensions and absorbed power

#### One H

214 x 171 x h 226 cm

4,5 kW Max

230 Vac 1N 50-60 Hz

400 Vac 3N 50-60 Hz

Su misura

Custom size

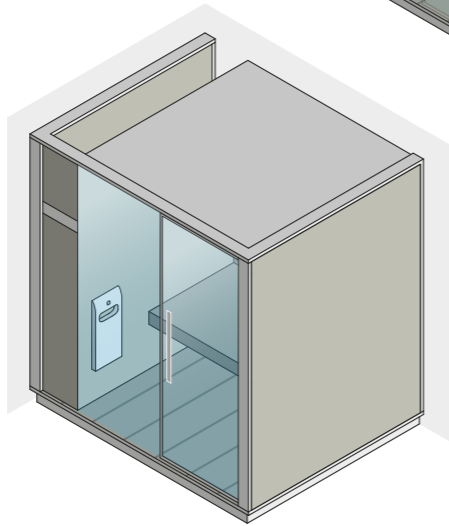
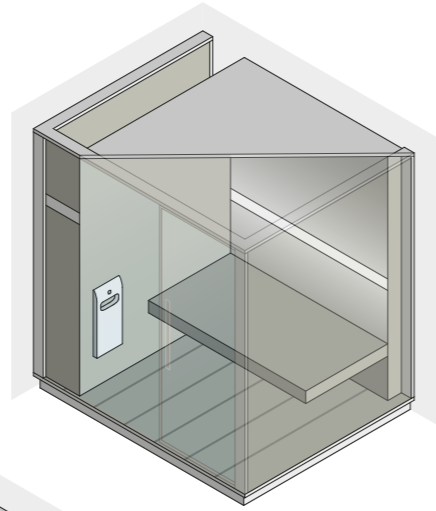

## One H

Design: \_\_\_\_\_ Talocci Design

One H è un box hammam coordinabile con la sauna One S. I prodotti One offrono grande versatilità nelle applicazioni in centri benessere, palestre o in casa grazie alla pulizia formale del design, facilmente abbinabile a contesti differenti. One H può inoltre garantire una eccellente qualità di vapore grazie al generatore Aquasteam 45.

- › One H utilizza Aquasteam 45 per la generazione del vapore, per un controllo totale di densità e igiene.
- › Disponibili in sette finiture standard, o con cromie personalizzate.

One H is a Hammam cubicle which matches the One S sauna. One products are extremely versatile and ideal for spas, gyms or private homes, thanks to the clean lines of their design which compliments any room. One H also produces top-quality steam, thanks to the Aquasteam 45 generator.

- › One H uses an Aquasteam 45 steam generator, for total steam density and hygiene control.
- › Available in seven standard finishes or with a personalised colour scheme.





The interior of One H is tiled in carefully-crafted Slimtech® grès porcelain to ensure contact with bare skin creates a warm, natural sensation.





## Materials

### SAND

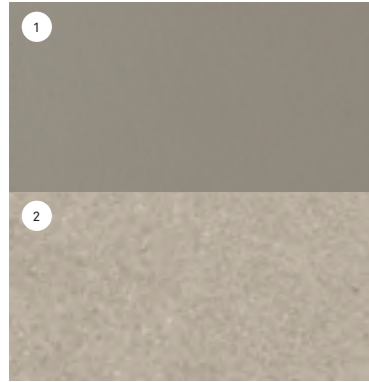

**SOFT SAND**  
Painted Aluminium (Gray) Ral 7030  
Slimtech Soft Sand

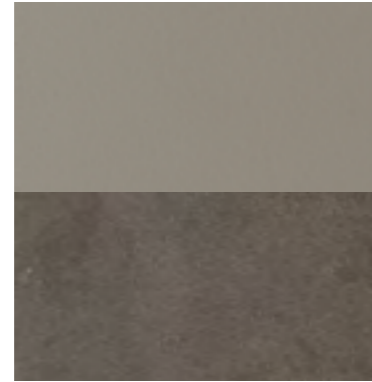

**SAND C030**  
Painted Aluminium (Gray) Ral 7030  
Slimtech Re-Evolution C030

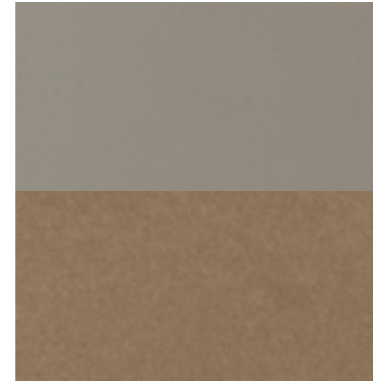

**SAND W030**  
Painted Aluminium (Gray) Ral 7030  
Slimtech Re-Evolution W030

### CLOUD



**WHITE CLOUD**  
Painted Aluminium (White)  
Ral 9010 SA810G  
Slimtech White Cloud

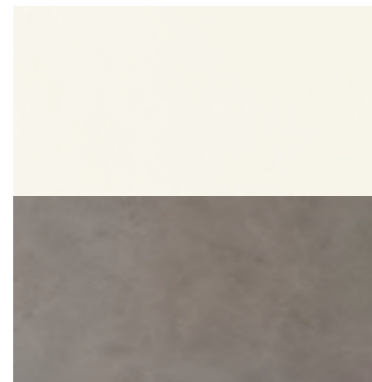

**CLOUD C020**  
Painted Aluminium (White)  
Ral 9010 SA810G  
Slimtech Re-Evolution C020

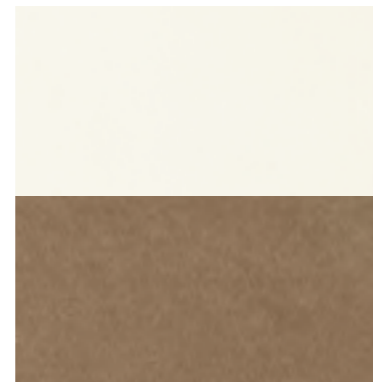

**CLOUD W030**  
Painted Aluminium (White)  
Ral 9010 SA810G  
Slimtech Re-Evolution W030

### STONE

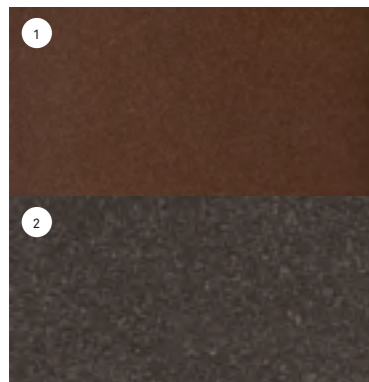

Painted Aluminium (Brown)  
YX355F 2525 Sablé  
Slimtech Black Stone

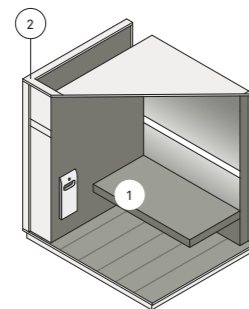

- 1 HAMMAM, PARETI ESTERNE E PEDANA  
HAMMAM, OUTSIDE AND PLATFORM
- 2 STRUTTURA ESTERNA  
OUTSIDE STRUCTURE

## Translations

### FRANÇAIS

#### One H

One H est une cabine hammam qui peut être coordonnée au sauna One S. Les produits One offrent de nombreuses applications possibles, dans des centres de bien-être, salles de gym ou à la maison, grâce à la netteté formelle du design, que l'on peut facilement combiner à différents contextes. One H garantit également une excellente qualité de vapeur grâce au générateur Aquasteam 45.

#### Caractéristiques :

One H utilise Aquasteam 45 pour la production de vapeur, pour un contrôle total de la densité et de l'hygiène. Disponible en sept finitions standard, ou avec des couleurs personnalisées.

### DEUTSCH

#### One H

One H ist eine mit der Sauna One S kombinierbare Hamam-Box. Die Produkte One bieten dank des klaren Designs, das zu verschiedenen Raumgestaltungen passt, vielfältige Einsatzmöglichkeiten in Wellnesscentern, Fitnessstudios oder zu Hause. Mit dem Generator Aquasteam 45 garantiert One H überdies eine hervorragende Dampfqualität.

#### Beschreibung:

One H nutzt Aquasteam 45 für die Dampferzeugung, für eine absolute Dichte- und Hygienekontrolle. Erhältlich in sieben Standardausführungen oder mit individueller Farbgestaltung.

### ESPAÑOL

#### One H

One H es una cabina hammam que se puede coordinar con la sauna One S. Los productos One ofrecen gran versatilidad en las aplicaciones, en centros de bienestar, gimnasios o en casa, gracias a la limpieza formal del diseño, que se combina fácilmente con contextos distintos. Además, One H puede garantizar una excelente calidad de vapor gracias al generador Aquasteam 45.

#### Características:

One H utiliza Aquasteam 45 para la generación del vapor, para un control total de densidad e higiene. Disponibles en siete acabados estándar o con colores personalizados.

### РУССКИЙ

#### One H

One H – это паровая кабина, сочетающаяся с сауной One S. Изделия серии One отличаются универсальным и лаконичным дизайном, который легко интегрируется в любое пространство: спа-салоны, фитнес-центры или в домашний интерьер. Хаммам One H оснащен парогенератором Aquasteam 45, который гарантирует безупречное качество пара.

#### Характеристики:

One H оснащен парогенератором Aquasteam 45, который позволяет максимально контролировать подачу пара и поддерживать высокий уровень гигиены. Три стандартных варианта отделки или отделка по индивидуальному заказу.

### 中文

#### One H

One H 是一种土耳其浴室模块，可以与 One S 桑拿房配套。One 系列产品的线条简洁、功能全面，满足不同空间的需求，非常适合水疗馆、健身馆或私人住宅。One H 采用 Aquasteam 45 蒸汽发生器，可以释放出高品质的蒸汽。

#### 特点:

One H 湿蒸土耳其浴使用 Aquasteam 45 型蒸汽发生器，提供高浓度且质地清洁的优质蒸汽。三种标准表面效果可供选择，或进行个性化颜色定制。

## Materiali

### Interno:

- Grès laminato 3,5 mm;
- Porte in vetro temperato 8 mm.

### Arredi e pedana:

- Grès laminato 3,5 mm accoppiato su vetro temperato 15 mm.

### Finiture esterne

- Alluminio verniciato.
- Pareti esterne a vista in grès laminato 3,5 mm.

### Caratteristiche/componenti hammam

- Aquasteam.
- Panche in grès laminato.
- Illuminazione con cromoterapia a Led RGB, 5 colori fissi, 4 cicli dinamici e luce bianca.

### Caratteristiche/componenti doccia

- Doccia a mano.
- Miscelatore termostatico con deviatore a 3 vie.
- Soffione doccia a soffitto 42 x 42 cm con funzioni pioggia e nebulizzazione.

## Materials

### Inside:

- 3.5 mm laminated grès porcelain;
- Doors in 8 mm tempered glass.

### Fittings and platform:

- 3.5 mm laminated grès porcelain fitted to 15 mm toughened glass.

### Outside wall finish

- Painted aluminium;
- Outside wall finish laminated grès porcelain 3.5 mm.

### Hammam features/components

- Aquasteam.
- Unglazed porcelain tile benches.
- Lighting system with Led RGB colour therapy, 5 fixed colours, 4 dynamic cycles and white light.

### Shower features/components

- Hand-held shower head.
- Thermostatic mixer with 3-way diverter.
- 42 x 42 cm ceiling-mounted shower head with rain and nebuliser functions.

## Dimensioni e consumo

### Dimensions and absorbed power

#### H-Small

- 131 x 92 x h 220 cm
- 3,0 kW max

#### H-Medium

- 152 x 102 x h 220 cm
- 3,0 kW max

#### H-Large

- 173 x 102 x h 220 cm
- 4,5 kW max

- Su misura
- Custom size

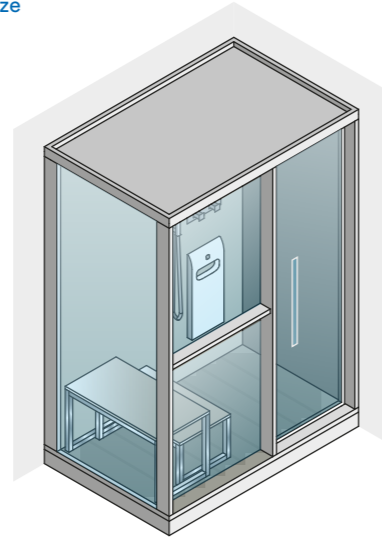



## H

Design: \_\_\_\_\_ Talocci Design

Serie di hammam con prestazioni professionali, completi di doccia e cromoterapia, ideali per completare il bagno di casa con un'area dedicata al benessere.

- › Tecnologia Aquasteam per la generazione del vapore: il massimo del controllo sulla qualità del tuo vapore.
- › Interno e arredi in grès laminato 3,5 mm, Porte in vetro temperato 8 mm.
- › Disponibile in sette varianti cromatiche.

A line of Hammams delivering professional performance, complete with shower and colour therapy, the ideal complement to a home bathroom with its own spa area.

- › Aquasteam steam generator technology for maximum control over the quality of your steam.
- › Interior and fittings in 3.5 mm laminated grès porcelain, 8 mm toughened glass doors.
- › Available in seven colour schemes.





Version: H-Medium.  
Finishes: Cloud - White Cloud.

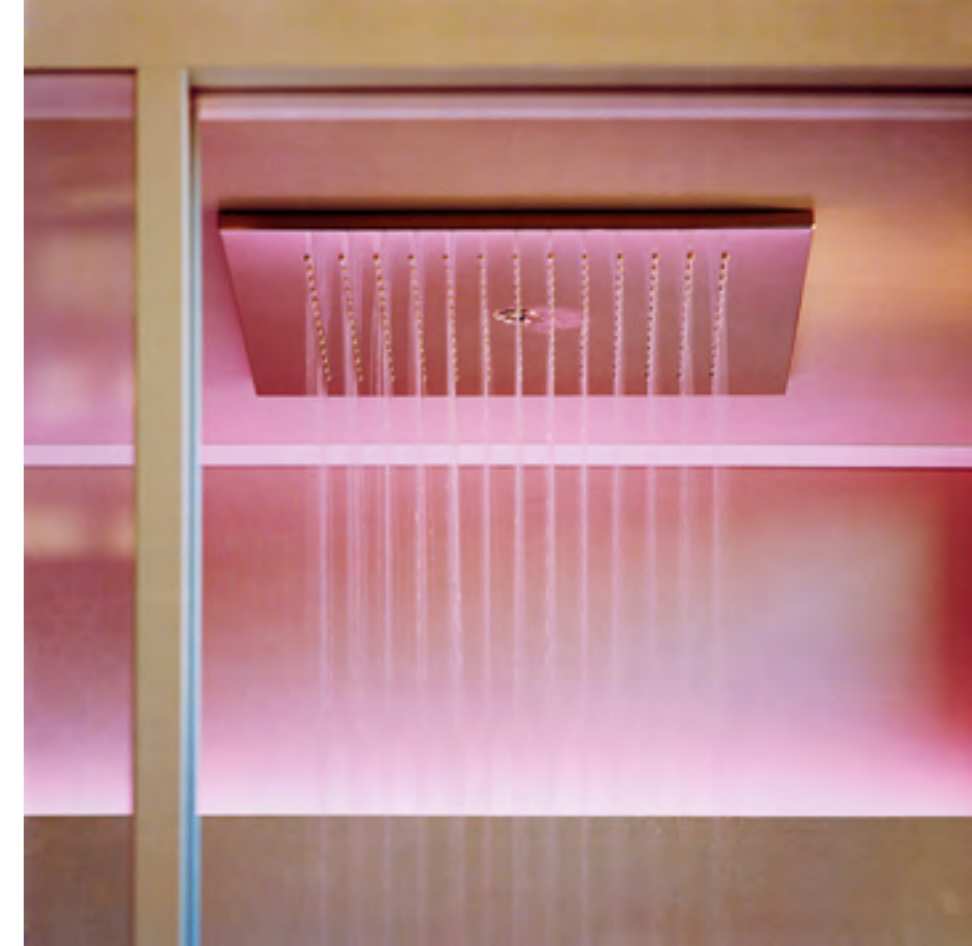

42 x 42 cm ceiling-mounted shower head  
with rain and nebuliser functions.



Acquasteam 45: the water delivery system is backlit to create a delightful effect of water seemingly gushing out of a natural spring in the wall.



## Materials

### SAND

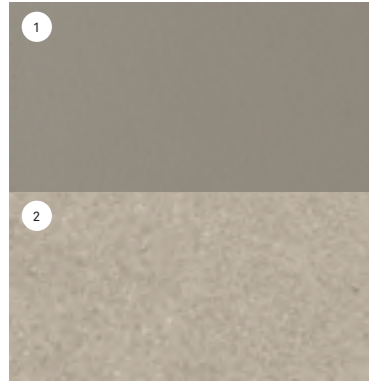

**SOFT SAND**  
Painted Aluminium (Gray) Ral 7030  
Slimtech Soft Sand

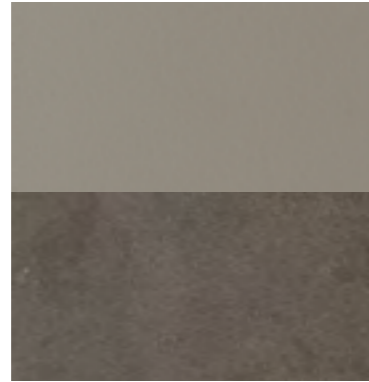

**SAND C030**  
Painted Aluminium (Gray) Ral 7030  
Slimtech Re-Evolution C030

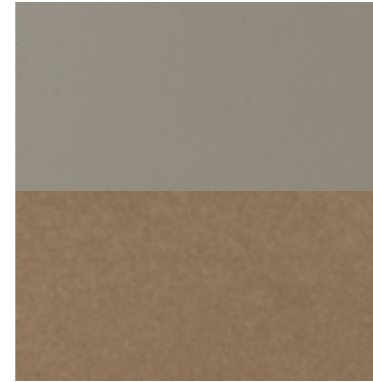

**SAND W030**  
Painted Aluminium (Gray) Ral 7030  
Slimtech Re-Evolution W030

### CLOUD



**WHITE CLOUD**  
Painted Aluminium (White)  
Ral 9010 SA810G  
Slimtech White Cloud

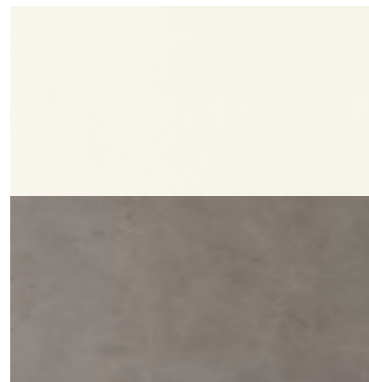

**CLOUD C020**  
Painted Aluminium (White)  
Ral 9010 SA810G  
Slimtech Re-Evolution C020

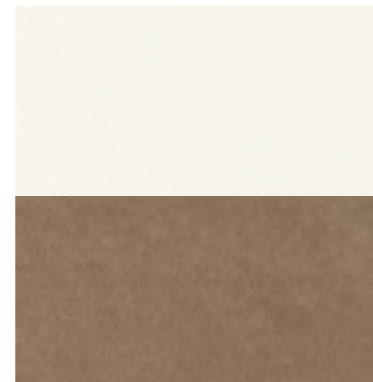

**CLOUD W030**  
Painted Aluminium (White)  
Ral 9010 SA810G  
Slimtech Re-Evolution W030

### STONE

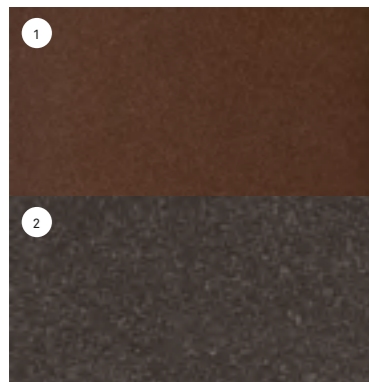

Painted Aluminium (Brown)  
YX355F 2525 Sablé  
Slimtech Black Stone

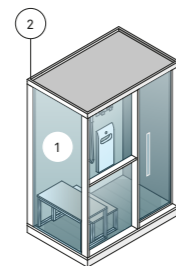

- 1 HAMMAM  
E PEDANA  
HAMMAM  
AND PLATFORM
- 2 STRUTTURA  
ESTERNA  
OUTSIDE  
STRUCTURE

## Translations

### FRANÇAIS

**H**  
Séries de hammams avec performances professionnelles, équipés de douche et chromothérapie, idéaux pour compléter votre salle de bains avec une zone dédiée au bien-être.

Caractéristiques :

Technologie Aquasteam pour la production de vapeur : le maximum du contrôle sur la qualité de votre vapeur. Intérieur et mobilier en grès laminé de 3,5 mm, portes en verre trempé de 8 mm. Disponible en sept variantes chromatiques.

### ESPAÑOL

**H**  
Serie de hammam con rendimiento profesional, equipados con ducha y cromoterapia, ideales para completar el baño de casa con una zona dedicada al bienestar.

Características:

Tecnología Aquasteam para la generación del vapor: el máximo del control sobre la calidad de tu vapor. Interno y mobiliario en Gres laminado 3,5 mm, puertas en vidrio templado de 8 mm. Disponible en siete variantes cromáticas.

### 中文

**H**  
经过专业配置的整体土耳其浴室系列，内含淋浴及彩色光谱疗法系统，是完整打造居家健康SPA的理想选择。

特点:

采用Aquasteam技术蒸汽发生器：提供全方位监控的高品质蒸汽。内部装饰采用3.5mm的Slimtech®超薄陶瓷层压板，门板采用经过淬火处理的8mm厚钢化玻璃。提供三种不同颜色的边框漆面。

### DEUTSCH

**H**  
Hamams mit professionellen Leistungen und integrierter Dusche und Farblichttherapie. Ideal, um das heimische Badezimmer um eine Wellnessecke zu ergänzen.

Beschreibung:

Dampferzeugung mit Aquasteam-Technologie: maximale Kontrolle der Qualität Ihres Dampfes. Inneres und Ausstattung aus laminiertem Feinsteinzeug, 3,5 mm; Türen aus gehärtetem 8-mm-Glas. Erhältlich in sieben Farbvarianten.

### РУССКИЙ

**H**  
Профессиональный хаммам с душем и цветным освещением великолепно украсит обстановку в любой душевой и бане.

Характеристики:

Парогенератор Aquasteam: позволяет максимально контролировать качество пара. Внутренняя отделка и предметы интерьера из ламинированного керамогранита 3,5 мм. Дверь из закаленного стекла 8 мм. Три варианта исполнения.

#### Rivestimenti interni

Marmo Carrara.  
Marmo Botticino.  
Marmo Marquina.

#### Vetrare di fondo

Vetro temperato serigrafato con smalto  
ceramico bianco.  
Vetro temperato finitura a specchio.

#### Vetrare a vista

Vetro camera temperato 25 mm nelle finiture:  
Rain, Trasparente.

#### Caratteristiche/Componenti

Generatore di vapore interno alla colonna.  
Fonte con ciotola in acciaio, finitura ramata.  
Panca in teck della Birmania al naturale  
con struttura in acciaio inox.  
Cromoterapia a Led RGB, 5 colori fissi, 4 cicli  
dinamici luce bianca a Led.  
Miscelatore con cartuccia progressiva e deviatore.  
Soffione doccia a soffitto con anticalcare.  
Doccia a mano.

#### ECC - Effe Comfort Control

Sistema che consente di gestire a distanza  
il bagno turco dal proprio dispositivo, tramite  
l'App Effegibi Experience. Disponibile su iOS.

#### ESS - Effe Sound System

Dispositivo con collegamento Bluetooth  
per l'ascolto di musica all'interno della sauna  
o dell'hammam.

#### Interior coverings

Carrara marble.  
Botticino marble.  
Marquina marble.

#### Back glass panels

Screen-printed toughened glass with white  
ceramic enamel.  
Mirror-Finish toughened glass.

#### Glass panels on view

25 mm double-glazed toughened glass:  
Rain, Transparent.

#### Features/Components

Steam generator inside the column.  
Spring with copper-finish steel bowl.  
Bench with natural-finish Burmese teak seat  
and stainless steel support.  
RGB Led colour therapy, 5 fixed colours,  
4 dynamic cycles white Led light.  
Mixer tap with flow regulator and diverter.  
Ceiling mounted anti-scale shower head.  
Hand-held shower head.

#### ECC - Effe Comfort Control

System that remotely controls the steam bath  
from your device, using the Effegibi Experience  
app. Available on iOS.

#### ESS - Effe Sound System

Device with Bluetooth connection for listening  
to music inside the sauna or hammam.

#### Dimensioni e consumo

##### Dimensions and absorbed power

190x130  
193,2 x 130 x h 219,5 cm  
4,5 kW max

190x90  
193,2 x 90 x h 219,5 cm  
3,0 kW max

150x130  
153,2 x 130 x h 219,5 cm  
4,5 kW max

150x90  
153,2 x 90 x h 219,5 cm  
3,0 kW max

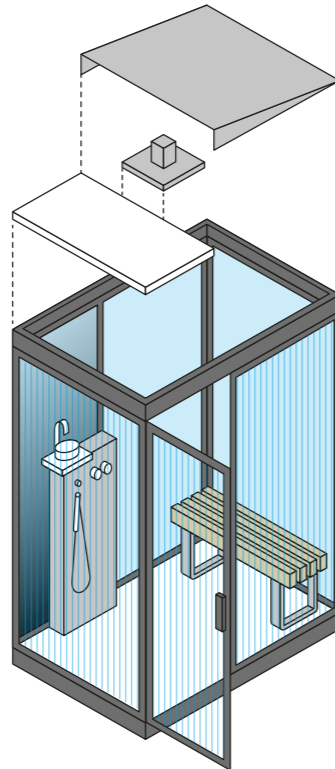

## Topkapi

Design: \_\_\_\_\_ Rodolfo Dordoni  
with Michele Angelini

Il vero lusso degli antichi hammam è rappresentata da Topkapi: rivestimenti in marmo Carrara, Marquina o Botticino e uno standard qualitativo senza uguali nella generazione del vapore.

- › Bagno turco completo di doccia, fonte, panche e cromoterapia.
- › Topkapi è dotato di una fonte rivestita in marmo di prima scelta, completa di ciotola in acciaio finitura ramata.
- › Pannello touch intuitivo e retroilluminato per gestire vapore, temperatura, luce e cromoterapia.

Topkapi represents the luxury of the traditional Hammam, its walls lined with Carrara, Marquina or Botticino marble and unequalled performance from the steam generator.

- › Steam bath complete with shower, spring, benches and colour therapy.
- › Topkapi comes with a spring clad in top quality marble, complete with a copper-finish steel bowl.
- › Intuitive, back-lit touch control panel operates the steam, temperature, lighting and colour therapy.





Finish: Marquina marble with rain-effect glass.

170



Topkapi / hammam /

171

# Materials

Pavimento, colonna  
Floor, column

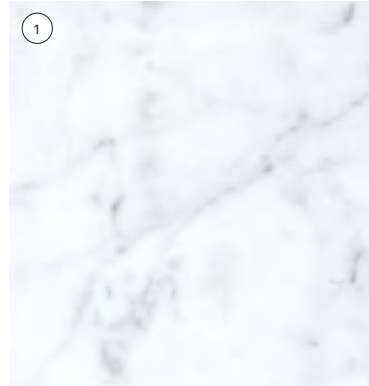

Marmo Carrara  
Carrara marble

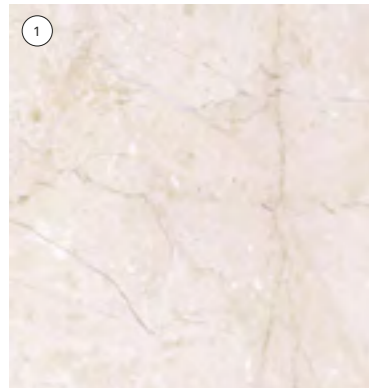

Marmo Botticino  
Botticino marble

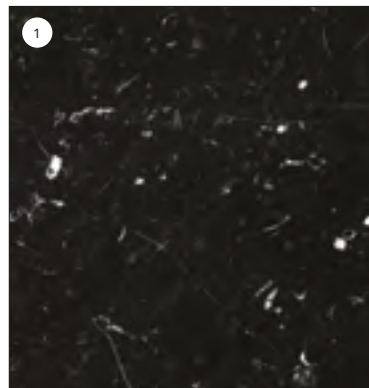

Marmo Marquina  
Marquina marble

Vetro di fondo  
Black glass

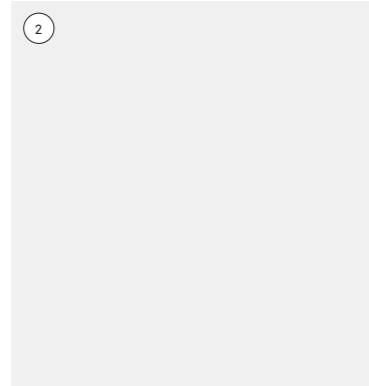

Toughened glass with white ceramic enamel  
Vetro temperato con smalto ceramico bianco

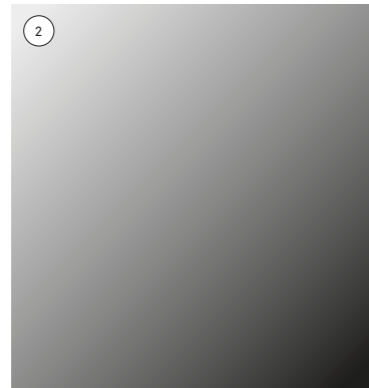

Mirror-finish toughened glass  
Vetro temperato finitura a specchio

Vetro frontale  
Front glass

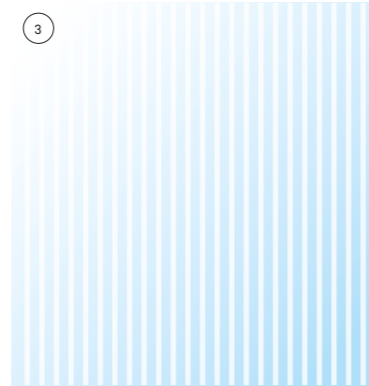

25 mm double-glazed toughened glass, Rain  
Vetro camera temperato 25 mm, Rain

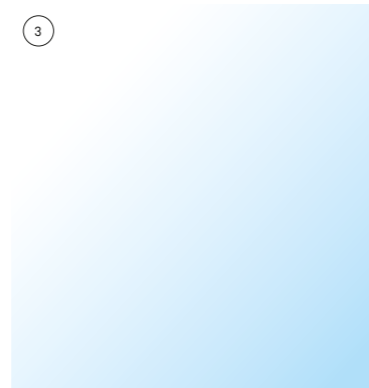

25 mm double-glazed toughened glass, Transparent  
Vetro camera temperato 25 mm, Trasparente

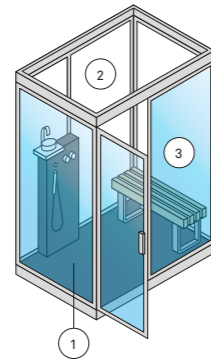

# Translations

FRANÇAIS

**Topkapi**

La véritable essence des anciens hammams est représentée par Topkapi : des revêtements en marbre Carrare, Marquina ou Botticino et un standard qualitatif inégalé dans la production de vapeur.

Caractéristiques :

Bain turc équipé de douche, fontaine, banquettes et chromothérapie.  
Topkapi est équipé d'une fontaine revêtue en marbre de premier choix, avec bol en acier finition cuivrée.  
Tableau tactile intuitif et rétro-illuminé pour gérer la vapeur, les températures, la lumière et la chromothérapie.

DEUTSCH

**Topkapi**

Topkapi verkörpert die echte Essenz der antiken Hamams: Auskleidungen aus Marmor – Carrara, Marquina oder Botticino – und ein Qualitätsstandard in der Dampferzeugung ohnegleichen.

Beschreibung:

Türkisches Dampfbad mit Dusche, Quelle, Bänke und Farblichttherapie.  
Topkapi bietet eine mit Marmor erster Wahl verkleidete Quelle mit einer Stahlschale in Kupferausführung.  
Intuitives und rückbeleuchtetes Touch-Bedienpaneel für die Dampf-, Temperatur-, Licht- und Farblichttherapie-Steuerung.

ESPAÑOL

**Topkapi**

La auténtica esencia de los antiguos hammam está representada por Topkapi: revestimientos en mármol de Carrara, Marquina o Mármol Botticino y un estándar de calidad sin iguales en la generación del vapor.

Características:

Baño turco equipado con ducha, fuente, bancos y cromoterapia.  
Topkapi dispone de una fuente revestida en mármol de primera calidad, equipado con cuenco en acero con acabado de cobre.  
Panel touch intuitivo y retroiluminado para gestionar vapor, temperaturas, luz y cromoterapia.

РУССКИЙ

**Топкапи**

Хаммам Топкапи объединяет в себе основные элементы древних турецких хаммамов: каменный интерьер из мрамора Каррара, Марквина или Боттичино и беспрецедентную технологию парогенерации.

Характеристики:

Турецкая баня с душем, умывальником, сиденьями и цветным освещением (хромотерапия).  
Умывальник из отборного мрамора со стальной чашей медного цвета.  
Сенсорная интуитивная панель с задней подсветкой позволяет управлять паром, температурой, освещением и хромотерапией.

中文

**Топкапи**

Топкапи 系列是古老的土耳其浴的纯粹代表：外饰面选用卡拉拉大理石、黑白根大理石或米黄大理石，配置了相同质量标准下外形各异的蒸汽发生器。

特点：

土耳其浴完整配置了淋浴、泉水、长椅以及彩色光谱疗法。  
Топкапи 系列采用优等大理石，配置抛光铜漆面处理的不锈钢水钵。  
带背光灯的碰触式控制面板，用来调节蒸汽、温度、灯光及彩色光谱疗法。



#### Materiali

Esterno, interno e arredi:  
Aspen termotrattato;  
Legno massiccio termotrattato:  
Noce canaletto.  
Porte e vetrate in cristalli chiari  
da 8 mm.

#### Caratteristiche/Componenti

Mensole esterne in metallo decappato.  
Illuminazione con luce bianca a Led.  
Stufa con pietre.  
Pannello di controllo finitura acciaio spazzolato.  
Funzione Energy Saver automatica.  
Impianto elettrico canalizzato.  
Panche.  
Griglia protezione stufa.  
Mastellino e mestolo in legno.  
Clessidra.

#### Optional

Biosauna.  
Cromoterapia a Led RGB.  
Double Mood Light.  
ECC - Effe Comfort Control.  
ESS - Effe Sound System.

#### Materials

Outside, inside and fitting:  
Heat-treated Aspen;  
Dark heat-treated solid wood;  
Canaletto walnut.  
Doors and glass panels in 8 mm  
clear glass.

#### Features/Components

External shelves in pickled metal.  
Wall lighting with Led white light.  
Heater with stones.  
Control panel with brushed steel finish.  
Automatic Energy Saver function.  
Electrical system with protected cable ducts.  
Benches.  
Protective grille for heater.  
Wooden bucket and ladle.  
Hourglass.

#### Optional

Bio-sauna.  
Colour Therapy Led RGB.  
Double Mood Light.  
ECC - Effe Comfort Control.  
ESS - Effe Sound System.

#### Dimensioni e consumo

##### Dimensions and absorbed power

Yoku S / D / G 45  
174 x 130 x h 214 cm  
Sauna 4,5 kW max  
230 Vac 1N 50-60Hz  
400 Vac 3N 50-60Hz  
Biosauna 4,5 kW max  
400 Vac 3N 50-60Hz

Yoku S / D / G 60  
174 x 170 x h 214 cm  
Sauna 6 kW max  
230 Vac 1N 50-60Hz  
400 Vac 3N 50-60Hz  
Biosauna 6 kW max  
400 Vac 3N 50-60Hz

Yoku S / D / G 80  
202 x 180 x h 214 cm  
Sauna 8 kW max  
230 Vac 1N 50-60Hz  
400 Vac 3N 50-60Hz  
Biosauna 9 kW max  
400 Vac 3N 50-60Hz

Yoku S / D / G 105  
230 x 200 x h 214 cm  
Sauna 10,5 kW max  
230 Vac 1N 50-60Hz  
400 Vac 3N 50-60Hz  
Biosauna 10,5 kW max  
400 Vac 3N 50-60Hz

Su misura  
Custom size

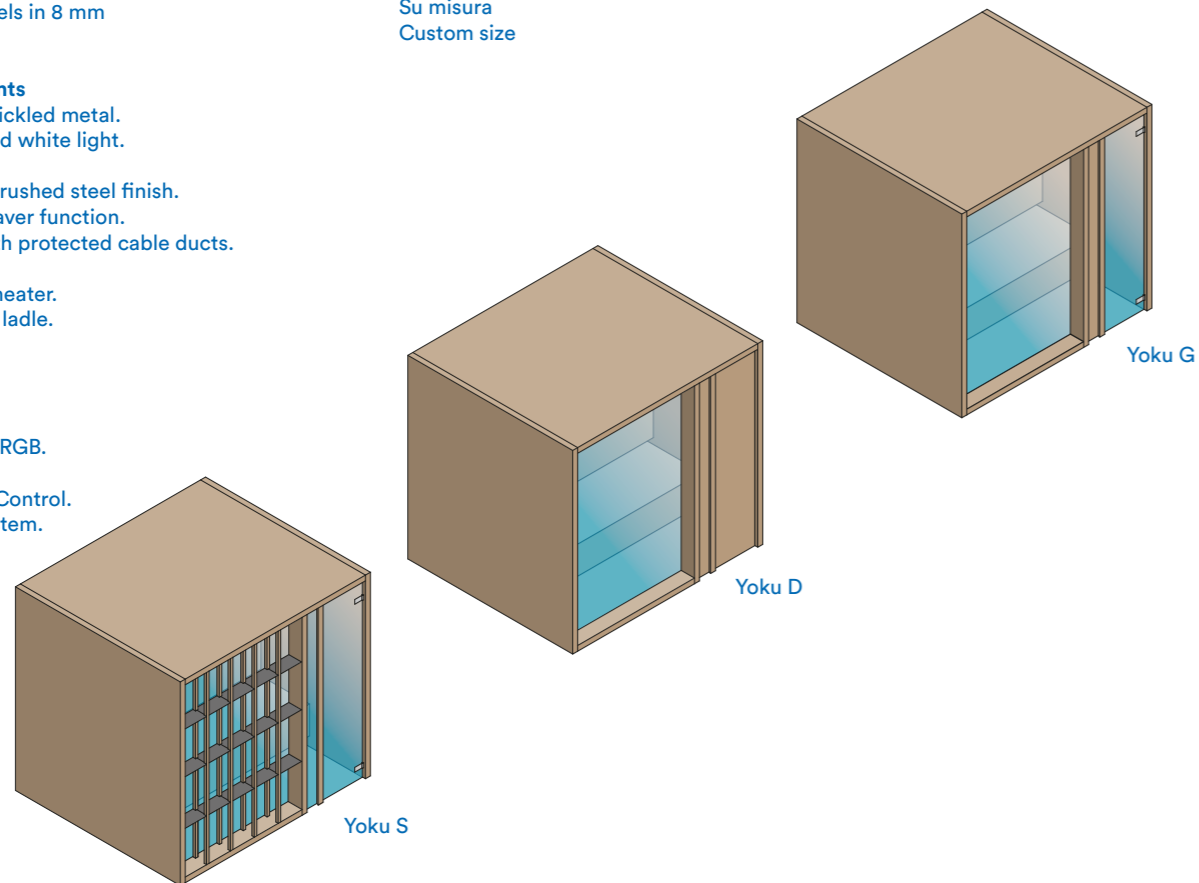

## Yoku

Design:

Marco Williams Fagioli  
(Zup Design)

Pur avendo un design essenziale, equilibrato e rigoroso, Yoku è accogliente, calda e naturale. L'ampia vetrata frontale è scandita all'esterno da elementi verticali in legno naturale che rendono lo spazio più intimo e diventano contemporaneamente elementi portanti di ripiani a giorno che dialogano con l'esterno.

> Tre diverse soluzioni estetiche declinabili in tre diverse essenze di legno rendono il progetto aperto a qualsiasi proposta progettuale.

> Il volume della stufa è integrato nella panca più bassa offrendo così un'immagine di grande linearità formale.

Yoku's essential, well-balanced minimalist design is also warm, welcoming and natural. The large glass panel at the front features vertical elements in natural wood on the outside, which make the space inside more private and provide shelving that is open to the external environment.

> Three different designs available in three different types of wood mean the sauna meets all aesthetic needs.

> The heater is built into the lowest bench thus displaying an uncluttered, linear effect.





< 1



< 2





Yoku S  
Finish: canaletto walnut.



Yoku D  
Finish: heat-treated Aspen.



Yoku G  
Finish: dark heat-treated solid wood.

## Materials



**Noce canaletto (Liscio)**  
Interno, esterno  
**Canaletto Walnut (Smooth)**  
Outside, inside, fittings



**Noce canaletto (Doghe)**  
Parete posteriore interna e arredi  
**Canaletto Walnut (Slats)**  
Inner back wall, fittings



**Legno massiccio termotrattato scuro (Liscio)**  
Interno, esterno  
**Dark heat-treated solid wood (Smooth)**  
Outside, inside, fittings

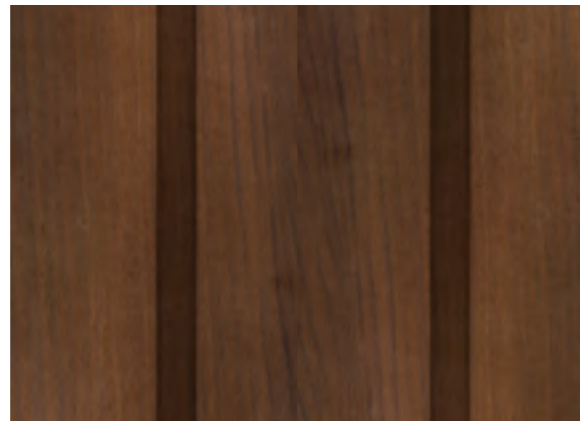

**Legno massiccio termotrattato scuro (Doghe)**  
Parete posteriore interna e arredi  
**Dark heat-treated solid wood (Slats)**  
Inner back wall, fittings

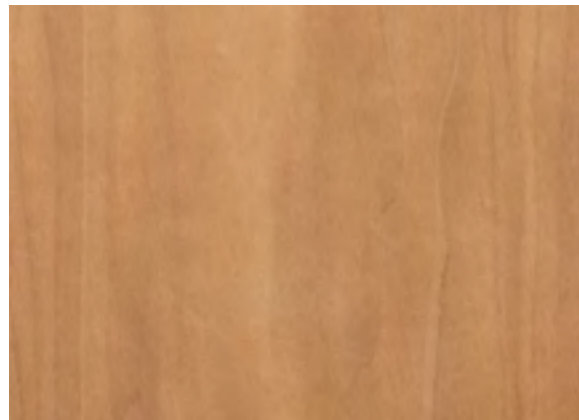

**Aspen termotrattato (Liscio)**  
Interno, esterno  
**Aspen heat-treated (Smooth)**  
Outside, inside, fittings



**Aspen termotrattato (Doghe)**  
Parete posteriore interna e arredi  
**Aspen heat-treated (Slats)**  
Inner back wall, fittings

## Translations

### FRANÇAIS

#### Yoku

Malgré son design essentiel, équilibré et rigoureux, Yoku est accueillant, chaud et naturel. La grande cloison vitrée frontale est constituée à l'extérieur par des éléments verticaux en bois naturel qui rendent l'espace plus intime, devenant en même temps des éléments porteurs de surfaces d'appui visibles qui dialoguent avec l'extérieur.

#### Caractéristiques :

Trois diverses solutions esthétiques déclinables en trois diverses essences de bois permettent de réaliser toutes propositions conceptuelles. Le volume du poêle est intégré dans la banquette inférieure, offrant ainsi une image de grande linéarité formelle. La version Yoku S prévoit une bibliothèque externe qui la rend particulièrement adaptée à toute intégration avec le salon.

### DEUTSCH

#### Yoku

Trotz ihres essentiellen, ausgewogenen und strengen Designs ist Yoku einladend, warm und natürlich. Die große frontale Verglasung wird außen durch vertikale Elemente aus Naturholz belebt, die den Innenraum intimer machen und gleichzeitig zu tragenden, offenen Regalelementen werden, die eine Verbindung nach außen schaffen.

#### Beschreibung:

Drei verschiedene Lösungen mit drei verschiedenen Holzarten machen den Weg frei für vielerlei Projektvorschläge. Der Ofen ist in die untere Bank integriert, wodurch ein formales lineares Bild entsteht. Die Ausführung Yoku S ist mit einem Außenregal ausgestattet, wodurch sie sich besonders gut in den Living-Bereich einfügen lässt.

### ESPAÑOL

#### Yoku

A pesar de tener un diseño esencial, equilibrado y riguroso, Yoku es acogedora, cálida y natural. La amplia pared de vidrio frontal cuenta en el exterior con elementos verticales de madera natural que proporcionan intimidad al espacio y se convierten al mismo tiempo en elementos de soporte para estantes que se relacionan con el exterior.

#### Características:

Tres soluciones estéticas diferentes declinables en tres esencias de madera distintas hacen que el proyecto esté abierto a cualquier propuesta proyectual. El volumen de la estufa está integrado en el banco más bajo ofreciendo de esta forma una imagen de gran linealidad formal. La versión Yoku S prevé una librería externa que hace que sea especialmente adecuada para integrarla en la zona de día.

### РУССКИЙ

#### Yoku

Несмотря на свой лаконичный, уравновешенный и строгий дизайн, сауна Yoku вносит в интерьер уютную, теплую и натуральную нотку. Большое переднее окно снаружи отделано вертикальными элементами из натуральной древесины, которые создают внутри сауны атмосферу уединения и одновременно выполняют функцию стеллажа, облагораживая интерьер всего помещения.

#### Характеристики:

Возможность выбора из трех вариантов дизайна и трех видов древесины позволяет максимально персонализировать проект сауны. Каменка, интегрированная в самый низкий полоч, усиливает строгую линейность дизайна. В версии Yoku S возможна установка внешнего стеллажа, который прекрасно впишется в интерьер гостиной.

### 中文

#### Yoku

Yoku 采用简约而均衡的极简主义设计，同时让人感受到温暖、热情和自然。正面的大块玻璃面板在外侧带有天然木材的垂直装饰元素，令内部空间更加私密，同时可以作为外部空间的开放式搁板。

#### 特点:

三种不同设计搭配三种不同木材，确保这款桑拿房可以满足不同的美学需求。底部长凳中整合了加热器，确保整体线条简洁、干净。Yoku S 配有外部书架，令其成为起居室的完美选择。

## Materiali

Versione Aspen naturale:

esterno, interno, arredi: Aspen naturale;  
vetri temperati chiari 10 mm.

Versione Aspen termotrattato:

esterno, interno, arredi: Aspen termotrattato;  
vetri temperati chiari 10 mm.

## Caratteristiche/Componenti

Illuminazione a parete con luce bianca a Led.

Stufa con pietre.

Pannello di controllo, finitura acciaio spazzolato.

Funzione Energy Saver automatica.

Impianto elettrico canalizzato.

Panche.

Griglia protezione stufa.

Mastellino e mestolo in legno.

Clessidra.

## Optional

Biosauna.

Cromoterapia a Led.

Mood Light (Led sottopanca).

ECC - Effe Comfort Control.

ESS - Effe Sound System.

Portasciugamani e mensola.

## Materials

Natural Aspen wood version:

outside, inside, fittings: natural Aspen wood;  
10 mm clear tempered glass.

Heat-treated Aspen wood version:

outside, inside, fittings: heat-treated  
Aspen wood;  
10 mm clear tempered glass.

## Features/Components

Wall lighting with Led white light.

Heater with stones.

Control panel with brushed steel finish.

Automatic energy saver function.

Electrical system with protected cable ducts.

Benches.

Protective grille for heater.

Wooden bucket and ladle.

Hourglass.

## Optional

Bio-sauna.

Colour Therapy Led RGB.

Mood Light (Led under the bench).

ECC - Effe Comfort Control.

ESS - Effe Sound System.

Towel holder and shelf.

## Dimensioni e consumo

### Dimensions and absorbed power

#### Air 120

283 x 252 x h 213 cm  
Sauna 12 kW max  
400 Vac 3N 50-60Hz  
Biosauna 12 kW max  
400 Vac 3N 50-60Hz

#### Air 80

247 x 182 x h 213 cm  
Sauna 8,0 kW max  
230 Vac 1N 50-60Hz  
400 Vac 3N 50-60Hz  
Biosauna 9,0 kW max  
400 Vac 3N 50-60Hz

#### Air 60

217 x 162 x h 213 cm  
Sauna 6,0 kW max  
230 Vac 1N 50-60Hz  
400 Vac 3N 50-60Hz  
Biosauna 6,0 kW max  
400 Vac 3N 50-60Hz

#### Air 105 Corner

247 x 182 x h 213 cm  
Sauna 10,5 kW max  
400 Vac 3N 50-60Hz  
Biosauna 10,5 kW max  
400 Vac 3N 50-60Hz

#### Air 80 Corner

217 x 162 x h 213 cm  
Sauna 8,0 kW max  
230 Vac 1N 50-60Hz  
400Vac 3N 50-60Hz  
Biosauna 9,0 kW max  
400 Vac 3N 50-60Hz

Su misura  
Custom size

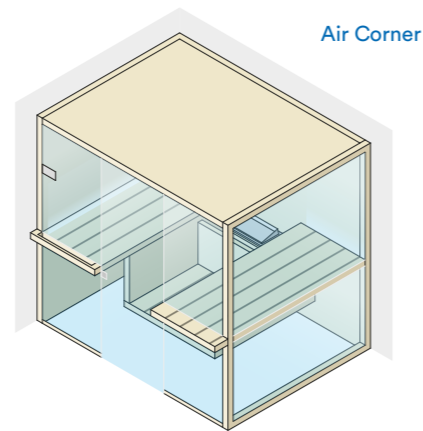

Air Corner

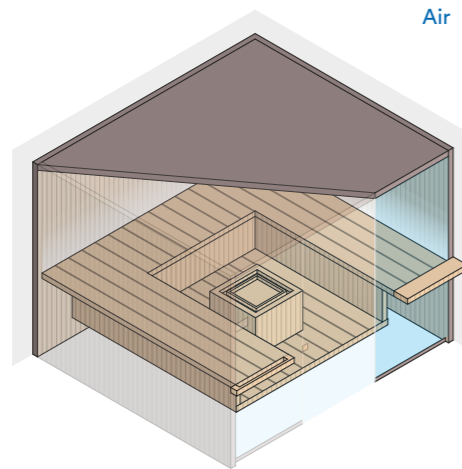

Air

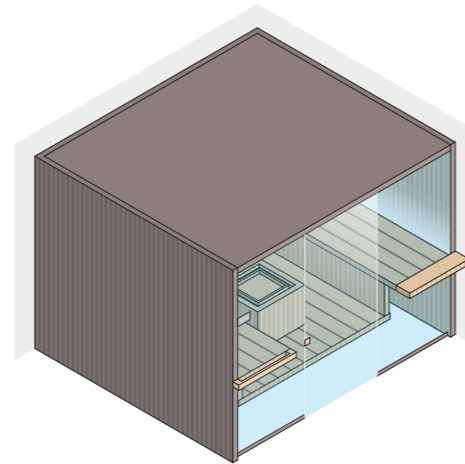

## Air

Design: \_\_\_\_\_ Talocci Design

Air è una sauna dal design originale e contemporaneo, caratterizzata dalla sospensione delle sedute e dalla simmetria delle linee, con la stufa in posizione centrale: la leggerezza diventa il carattere dominante.

- > Le panche sospese alleggeriscono il design e consentono l'installazione sul pavimento esistente.
- > La stufa in posizione centrale fa di Air un luogo di incontro, dove rilassarsi in compagnia.
- > I piani delle panche diventano all'esterno un portasciugamani e un funzionale piano di appoggio.
- > Arredamenti realizzati in pregiato legno Aspen al naturale o termotrattato, molto resistente nel tempo.
- > Ampie superfici vetrate a tutta altezza in cristallo temperato da 10 mm.

The Air sauna is an original, contemporary design which, as the name implies, features a light and airy feel created by the suspended seating and symmetrical lines with the heater in a central position.

- > The suspended benches create a lightweight design enabling the sauna to be installed on existing flooring.
- > The centrally placed heater makes Air the ideal meeting place to relax in company.
- > The bench seats project outside, creating a handy towel holder and shelf.
- > The fittings are made of luxurious aspen wood, either natural or heat-treated for a long life.
- > Ample glass surfaces in 10mm toughened glass.



1 >



2 >





Heat-treated Aspen wood  
and 10mm toughened glass side.

190

Air / sauna /

191



Heat-treated Aspen wood  
and 10mm toughened glass side.



Natural Aspen wood.

Air

Air



Heat-treated Aspen wood  
and 10mm toughened glass side.

194

Air / sauna /

195





The bench seats project outside, creating a handy towel holder and shelf.

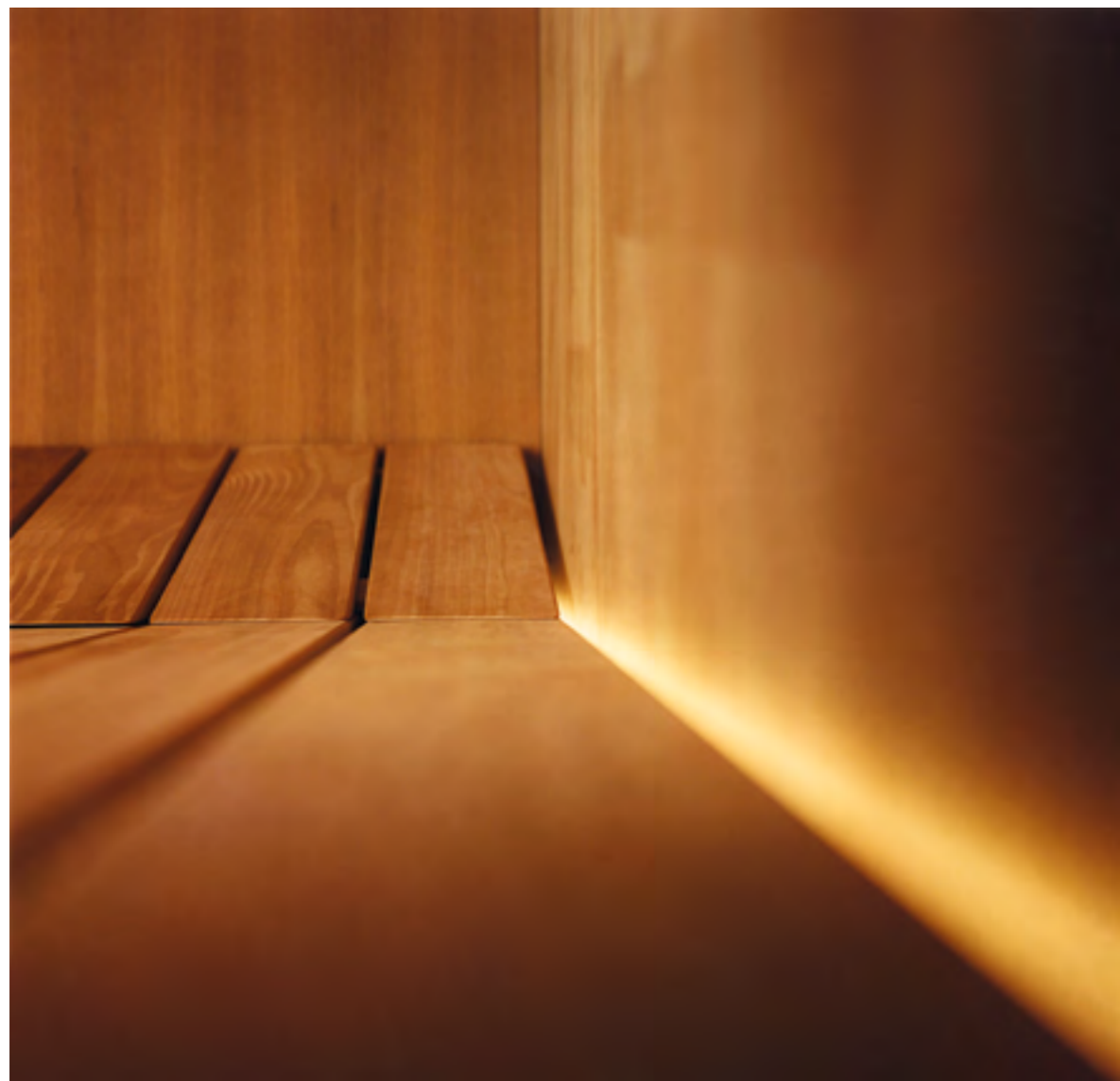
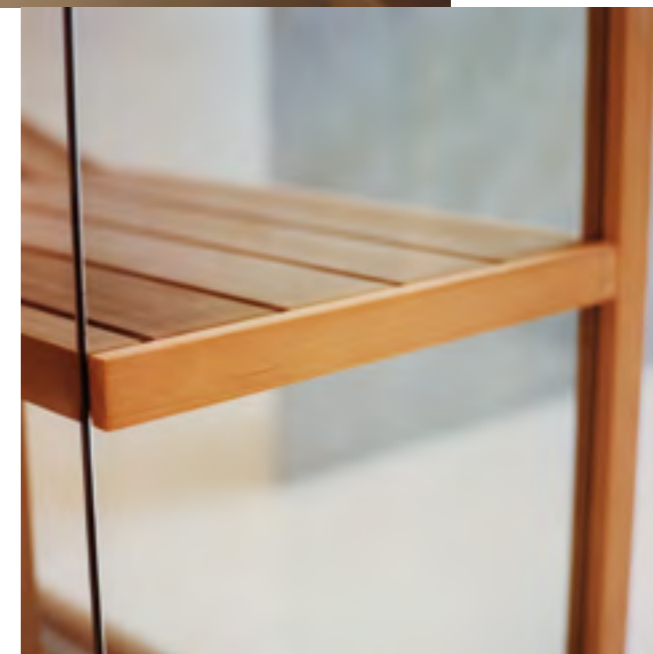

## Materials



**Aspen naturale**  
Interno, esterno, arredi  
**Natural Aspen**  
Outside, inside, fittings

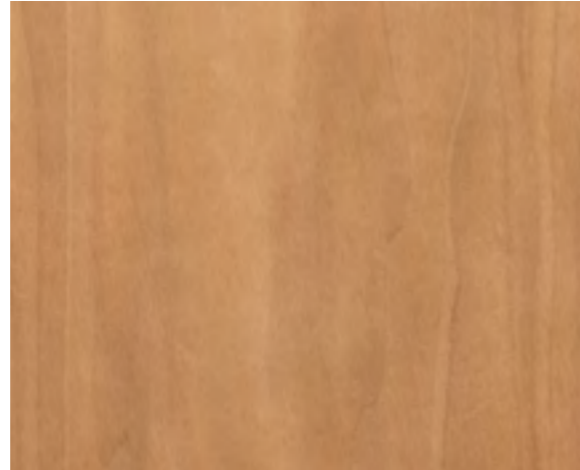

**Aspen termotrattato**  
Interno, esterno, arredi  
**Heat-treated Aspen**  
Outside, inside, fittings

## Translations

### FRANÇAIS

#### Air

Air est un sauna au design original et contemporain, caractérisé par la suspension des banquettes et par la symétrie des lignes, avec le poêle positionné au centre : la légèreté devient le caractère dominant.

#### Caractéristiques :

Les banquettes suspendues rendent le design plus léger et permettent l'installation sur le sol existant. Le poêle positionné au centre fait d'Air un lieu de rencontre, où se détendre en compagnie. Les mobiliers sont réalisées en bois précieux Aspen au naturel ou thermo-traité, très résistant dans le temps. Les plans des banquettes deviennent à l'extérieur un porte-serviettes et un plan d'appui fonctionnel. De grandes surfaces vitrées sur toute la hauteur en cristal trempé de 10 mm.

### DEUTSCH

#### Air

Air ist eine Sauna im originalen und modernen Design. Sie zeichnet sich durch schwebend wirkende Sitzflächen und symmetrische Linien sowie den mittig positionierten Ofen aus: Leichtigkeit wird zum dominierenden Charakterzug.

#### Beschreibung:

Die schwebenden Bänke erleichtern das Design und ermöglichen die Installation auf existierenden Böden. Der mittig positionierte Ofen macht Air zu einem Ort der Begegnung, um sich in Gesellschaft zu entspannen. Das Ausstattung bestehen aus hochwertigem dauerhaft sehr resistentem Espenholz, naturbelassen oder thermisch behandelt. Die Bankflächen werden außerhalb zu einem Handtuchhalter und einer praktischen Ablage. Große Glasflächen bis zur Decke aus gehärtetem 10-mm-Glas.

### ESPAÑOL

#### Air

Air es una sauna de diseño original y contemporáneo, caracterizada por la suspensión de los asientos y por la simetría de las líneas, con la estufa en posición central: la ligereza se convierte en su característica dominante.

#### Características:

Los bancos suspendidos aligeran el diseño y permiten la instalación en el suelo existente. La estufa en posición central convierte Air en un lugar de encuentro, dónde relajarse en compañía. La parte interna y las paredes están realizadas en madera Aspen de calidad, al natural o tratada térmicamente, muy resistente en el tiempo. Las superficies de los bancos se convierten, en la parte externa, en un toallero y una funcional base de apoyo. Amplias superficies de vidrio hasta el techo en cristal templado de 10 mm. Las fuentes luminosas de Led colocadas debajo de los bancos destacan la ligereza del ambiente.

### РУССКИЙ

#### Air

Air – это сауна с оригинальным современным дизайном, в котором доминирует концепция воздушной легкости, выраженная подвешенной конструкцией лежаков, симметричными линиями и центральным расположением каменки.

#### Характеристики:

Подвешенные лежаки делают конструкцию более легкой и позволяют установить сауну на существующий пол. Каменка, расположенная по центру кабины, делает Air местом встречи и релаксации в компании.

Внутренняя отделка и стены выполнены из ценной и долговечной древесины литовской осины (с термообработкой или в натуральном виде).

Наружные торцы лежаков выполняют функцию держателей для полотенец и практичных полок.

Обширная площадь остекления во всю высоту фасада: закаленное стекло 10 мм.

### 中文

#### Air

Air 系列桑拿浴为原创现代设计，悬空式座椅，对称式结构线条，居中式桑拿炉：简洁轻便正是这款桑拿房的主要特点。

#### 特点:

悬空长椅使得设计更显轻巧，并且桑拿房可以安装在已经铺好地板的地面上。居中式桑拿炉使得Air系列桑拿房成为相聚的休闲场所，人们可以在相互陪伴下休息放松。

内部及墙板选用产自立陶宛的天然或热恒温处理的白杨木材，使得此款桑拿房长久耐用。

长凳的层次在桑拿房外成为搭放毛巾或可用的背靠。

桑拿房表面大范围采用经过高温淬火处理的钢化玻璃，厚度为10mm。

#### Materiali

Esterno, Interno e arredi:  
Hemlock Canadese;  
Vetri temperati chiari 10 mm.

#### Caratteristiche/Componenti

Illuminazione a parete con luce bianca a Led.  
Stufa con pietre.  
Pannello di controllo, finitura acciaio spazzolato.  
Funzione Energy Saver automatica.  
Impianto elettrico canalizzato.  
Panche.  
Griglia protezione stufa.  
Mastellino e mestolo in legno.  
Clessidra.

#### Optional

Biosauna.  
Cromoterapia a Led.  
Mood Light (Led sottopanca).  
ECC - Effe Comfort Control.  
ESS - Effe Sound System.  
Pedane a pavimento.

#### Materials

Outside, Inside and Fitting:  
Canadian Hemlock;  
10 mm clear tempered glass.

#### Features/Components

Wall lighting with Led white light.  
Heater with stones.  
Control panel with brushed steel finish.  
Automatic energy saver function.  
Electrical system with protected cable ducts.  
Benches.  
Protective grille for heater.  
Wooden bucket and ladle.  
Hourglass.

#### Optional

Bio-sauna.  
Colour Therapy Led RGB.  
Mood Light (Led under the bench).  
ECC - Effe Comfort Control.  
ESS - Effe Sound System.  
Floor platforms.

#### Dimensioni e consumo

##### Dimensions and absorbed power

#### Sky Corner 80

200 x 180 x h 201 cm  
Sauna 8,0 kW max  
230 Vac 1N 50-60Hz  
400 Vac 3N 50-60Hz  
Biosauna 9,0 kW max  
400 Vac 3N 50-60Hz

#### Sky Corner 60

200 x 150 x h 201 cm  
Sauna 6,0 kW max  
230 Vac 1N 50-60Hz  
400 Vac 3N 50-60Hz  
Biosauna 6,0 kW max  
400 Vac 3N 50-60Hz

#### Sky Corner 45

170 x 130 x h 201 cm  
Sauna 4,5 kW max  
230 Vac 1N 50-60Hz  
400 Vac 3N 50-60Hz  
Biosauna 4,5 kW max  
400 Vac 3N 50-60Hz

Su misura  
Custom size

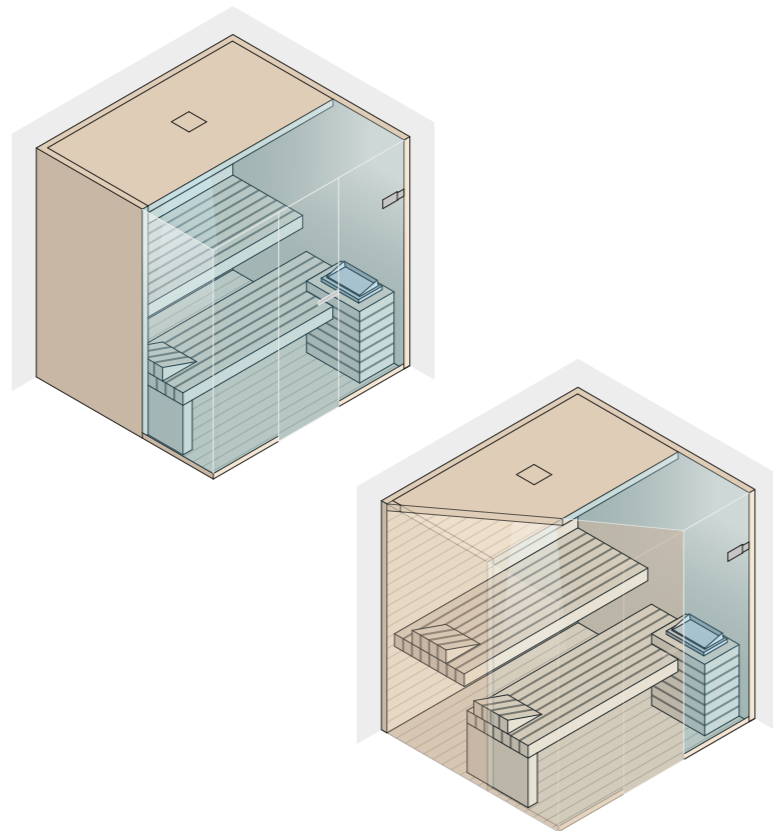

## Sky Corner

Design: \_\_\_\_\_ Talocci Design

Nuovo modello della linea Sky, con una superficie vetrata ancora più ampia: un vero e proprio angolo trasparente di luce e benessere.

- › Sauna certificata, realizzata in pregiato legno canadese Hemlock e vetri temperati 10 mm.
- › Superficie vetrata estremamente ampia: parete frontale, porta, soffitto e parete laterale.
- › Grande versatilità, ideale per realizzazioni su misura.

A new addition to the Sky line, with more generous glass surfaces, a corner radiating light and wellbeing.

- › Certified sauna made of prized Canadian hemlock wood and 10mm toughened glass panels.
- › Extremely generous glass surfaces: front wall, door, ceiling and side wall.
- › Extremely versatile, ideal for made-to-measure solutions.









The Sky Corner interior can be enhanced with colour therapy and under-bench LED lighting (optional)



The larger glass surfaces emphasise the design features of this line.

## Materials



**Hemlock Canadese (Liscio)**  
Interno, esterno, pareti laterali  
**Canadian Hemlock (Smooth)**  
Outside, inside, side walls



**Hemlock Canadese (Doghe)**  
Parete posteriore interna, arredi  
**Canadian Hemlock (Slats)**  
Inner back wall, fittings

## Translations

### FRANÇAIS

#### Sky Corner

Nouveau modèle de la ligne Sky, avec une surface vitrée encore plus ample : un véritable coin transparent de lumière et de bien-être.

#### Caractéristiques :

Sauna certifié, réalisé en bois précieux Hemlock canadien et vitres trempées de 10 mm.  
Surface vitrée extrêmement ample : paroi frontale, porte, plafond et paroi latérale.  
Grande versatilité, idéal pour des réalisations sur mesure.

### ESPAÑOL

#### Sky Corner

Nuevo modelo de la línea Sky, con una superficie de vidrio todavía más amplia: un auténtico remanso transparente de luz y bienestar.

#### Características:

Sauna certificada, realizada en madera canadiense Hemlock de calidad y vidrios templados de 10 mm.  
Superficie de vidrio sumamente amplia: pared frontal, puerta, techo y pared lateral.  
Gran versatilidad, ideal para proyectos a medida.

### 中文

#### Sky Corner

SKY 系列的新款桑拿房，更大范围采用玻璃面板：营造了一个明亮、舒适的透明角落。

#### 特点:

通过认证的整体桑拿房，使用珍贵的加拿大铁杉木，以及厚度为10mm的经过淬火处理的低排放钢化玻璃。桑拿浴室正面、门、顶部均采用玻璃面板，赋予了SKY系列极度透明而轻盈的感受。适用性极广，为定制款桑拿浴室的最理想选择。

### DEUTSCH

#### Sky Corner

Neues Modell der Linie Sky, mit einer noch größeren Glasfläche. Eine wahrhaftige transparente und von Licht erfüllte Wohlfühlecke.

#### Beschreibung:

Zertifizierte Sauna, gefertigt aus hochwertigem kanadischen Hemlock-Holz und gehärtetem Niederemissionsglas, 10 mm.  
Extrem große Glasfläche: Front, Tür, Decke und Seite.  
Besonders vielseitig, ideal für Anfertigungen nach Maß.

### РУССКИЙ

#### Sky Corner

Новая стильная модель линии Sky отличается оригинальным углом из прочного прозрачного стекла, пропускающего в помещение парной еще больше света.

#### Характеристики:

Сауна сертифицирована, она изготовлена из отборной древесины канадского хемлока и закаленного стекла 10 мм с низкой эмиссионной способностью.  
Большая площадь остекления: фасад, дверь, потолок и боковая стена.  
Благодаря своей универсальной стилистике модель идеально подходит для разработки индивидуальных проектов.

#### Materiali

Esterno, Interno e arredi:  
Hemlock Canadese.  
Vetri temperati chiari 10 mm.

#### Caratteristiche/Componenti

Illuminazione a parete con luce bianca a led.  
Stufa con pietre.  
Pannello di controllo finitura acciaio spazzolato.  
Funzione Energy Saver automatica.  
Impianto elettrico canalizzato.  
Panche.  
Griglia protezione stufa.  
Mastellino e mestolo in legno.  
Clessidra.

#### Optional

Biosauna.  
Cromoterapia a Led.  
Mood Light (Led sottopanca).  
ECC - Effe Comfort Control.  
ESS - Effe Sound System.  
Pedane a pavimento.

#### Materials

Outside, Inside and Fitting:  
Canadian Hemlock.  
10 mm clear tempered glass.

#### Features/Components

Wall lighting with Led white light.  
Heater with stones.  
Control panel with brushed steel finish.  
Automatic energy saver function.  
Electrical system with protected cable ducts.  
Benches.  
Protective grille for heater.  
Wooden bucket and ladle.  
Hourglass.

#### Optional

Bio-sauna.  
Colour Therapy Led RGB.  
Mood Light (Led under the bench).  
ECC - Effe Comfort Control.  
ESS - Effe Sound System.  
Floor platforms.

#### Dimensioni e consumo

#### Dimensions and absorbed power

##### Sky 80

200 x 180 x h 201 cm  
Sauna 8 kW max  
230 Vac 1N 50-60Hz  
400 Vac 3N 50-60Hz  
Biosauna 9 kW max  
400 Vac 3N 50-60Hz

##### Sky 60

200 x 150 x h 201 cm  
Sauna 6 kW max  
230 Vac 1N 50-60Hz  
400 Vac 3N 50-60Hz  
Biosauna 6 kW max  
400 Vac 3N 50-60Hz

##### Sky 40

170 x 130 x h 201 cm  
Sauna 4 kW max  
230 Vac 1N 50-60Hz  
Biosauna 4,5 kW max  
400 Vac 3N 50-60Hz

##### Sky 30

130 x 130 x h 201 cm  
Sauna 3 kW max  
230 Vac 1N 50-60Hz  
Biosauna 3 kW max  
230 Vac 1N 50-60Hz

Su misura  
Custom size

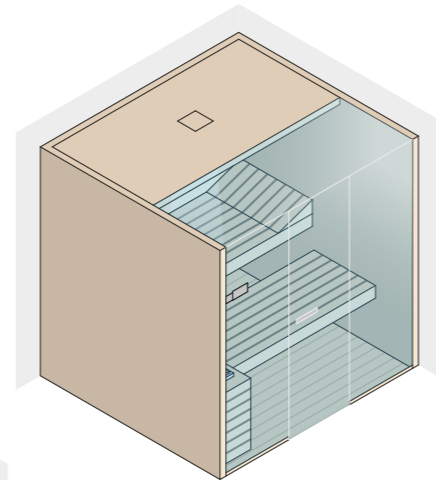
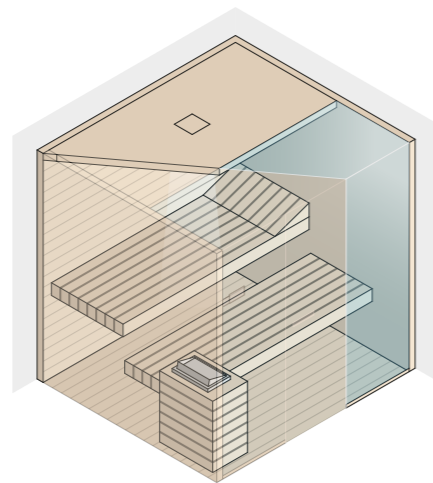

## Sky

Design: \_\_\_\_\_ Talocci Design

Una sauna con un'estetica estremamente versatile, caratterizzata da ampie vetrate che arrivano fino al soffitto: un oggetto luminoso e leggero, perfetto per ogni ambiente.

- › Sauna certificata, realizzata in pregiato legno canadese Hemlock e vetri temperati da 10 mm.
- › Parete frontale, porta e soffitto in vetro donano a Sky estrema trasparenza e leggerezza.
- › Grande versatilità, ideale per realizzazioni su misura.

A sauna with extremely versatile design features, with wide glass panels reaching right up to the ceiling that create a light and airy feel that is perfect for any environment.

- › Certified sauna made of prized Canadian hemlock wood and 10mm toughened glass panels.
- › The glass front wall, door and ceiling give Sky an extremely light, airy look.
- › Extremely versatile, ideal for made-to-measure solutions





## Materials

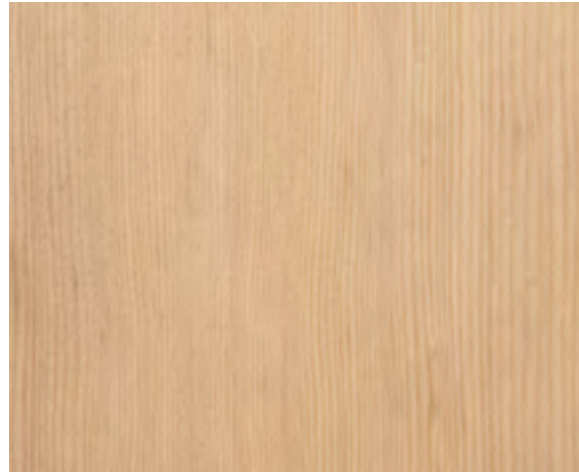

**Hemlock Canadese (Liscio)**  
Interno, esterno e pareti laterali  
**Canadian Hemlock (Smooth)**  
Outside, inside and side walls



**Hemlock Canadese (Doghe)**  
Parete posteriore interna, arredi  
**Canadian Hemlock (Slats)**  
Inner back wall, fittings

## Translations

### FRANÇAIS

#### Sky

Un sauna avec une esthétique extrêmement versatile, caractérisé par de grandes cloisons vitrées qui arrivent jusqu'au plafond : un objet lumineux et léger, parfait pour chaque pièce.

#### Caractéristiques :

Sauna certifié, réalisé en bois précieux Hemlock canadien et vitres trempées de 10 mm.

Paroi frontale, porte et plafond en verre confèrent à Sky une extrême transparence et légèreté.

Grande versatilité, idéal pour des réalisations sur mesure.

### DEUTSCH

#### Sky

Eine Sauna mit einem sehr vielseitigen Design. Sky zeichnet sich durch große Verglasungen aus, die bis zur Decke reichen, und ist ein helles, leichtes und in jedes Ambiente passendes Element.

#### Beschreibung:

Zertifizierte Sauna, gefertigt aus hochwertigem kanadischen Hemlock-Holz und gehärtetem Niederemissionsglas, 10 mm.

Die Front, die Tür und die Decke aus Glas verleihen Sky extreme Transparenz und Leichtigkeit.

Besonders vielseitig, ideal für Anfertigungen nach Maß.

### ESPAÑOL

#### Sky

Una sauna con una estética sumamente versátil, caracterizada por amplias paredes de vidrio que llegan hasta el techo: un objeto luminoso y ligero, perfecto para cada ambiente.

#### Características:

Sauna certificada, realizada en madera canadiense Hemlock de calidad y vidrios templados de 10 mm.

Pared frontal, puerta y techo en vidrio aportan a Sky una extrema transparencia y ligereza.

Gran versatilidad, ideal para proyectos a medida.

### РУССКИЙ

#### Sky

Универсальная стилистическая концепция сауны достигается за счет прозрачного стекла, установленного во всю высоту фасада сауны: благодаря такой легкой конструкции модель идеально гармонирует с любым интерьером.

#### Характеристики:

Сауна сертифицирована, она изготовлена из отборной древесины канадского хемлока и закаленного стекла 10 мм с низкой эмиссионной способностью.

Стеклянные фасад, двери и потолок сауны Sky стирают границы пространства и дарят ощущение свободы.

Благодаря своей универсальной стилистике модель идеально подходит для разработки индивидуальных проектов.

### 中文

#### Sky

桑拿浴室的外观具有极为广泛的适用性，大范围的玻璃面板可以直达浴室顶端：为您创造一个明亮而轻盈的桑拿浴室，适合与任意环境完美搭配。

#### 特点:

通过认证的整体桑拿房，使用珍贵的加拿大铁杉木，以及厚度为10mm的经过淬火处理的低排放钢化玻璃。

桑拿浴室正面、门、顶部均采用玻璃面板，赋予了SKY系列极度透明而轻盈的感受。

适用性极广，为定制款桑拿浴室的最理想选择。

#### Materiali

Esterno, interno e arredi:

- Hemlock Canadese;
- Abete di Svezia.

Vetri temperati chiari 8 mm.

#### Caratteristiche/Componenti

Illuminazione a parete con luce bianca a Led.

Stufa con pietre.

Pannello di controllo, finitura acciaio spazzolato.

Funzione Energy Saver automatica.

Impianto elettrico canalizzato.

Panche.

Griglia protezione stufa.

Mastellino e mestolo in legno.

Clessidra.

#### Optional

Biosauna.

Cromoterapia a Led.

Mood Light (Led sottopanca).

ECC - Effe Comfort Control.

ESS - Effe Sound System.

Pedane a pavimento.

#### Materials

Outside, Inside and Fitting:

- Canadian Hemlock;
- Swedish Fir Wood.

8 mm clear tempered glass.

#### Features/Components

Wall lighting with Led white light.

Heater with stones.

Control panel with brushed steel finish.

Automatic energy saver function.

Electrical system with protected cable ducts.

Benches.

Protective grille for heater.

Wooden bucket and ladle.

Hourglass.

#### Optional

Bio-sauna.

Colour Therapy Led RGB.

Mood Light (Led under the bench).

ECC - Effe Comfort Control.

ESS - Effe Sound System.

Floor platforms.

#### Dimensioni e consumo

#### Dimensions and absorbed power

##### Auki 60

228 x 170 x h 201 cm

Sauna 6 kW max

230 Vac 1N 50-60Hz

400 Vac 3N 50-60Hz

Biosauna 6 kW max

400 Vac 3N 50-60Hz

##### Auki 45

202 x 152 x h 201 cm

Sauna 4,5 kW max

230 Vac 1N 50-60Hz

400 Vac 3N 50-60Hz

Biosauna 4,5 kW max

400 Vac 3N 50-60Hz

##### Auki 40

189 x 126 x h 201 cm

Sauna 4 kW max

230 Vac 1N 50-60Hz

Biosauna 4,5 kW max

400 Vac 3N 50-60Hz

##### Auki 30

128 x 126 x h 201 cm

Sauna 3 kW max

230 Vac 1N 50-60Hz

Biosauna 2,5 kW max

230 Vac 1N 50-60Hz

Su misura

Custom size

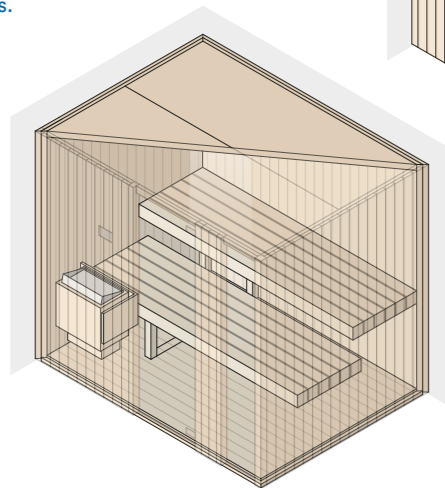
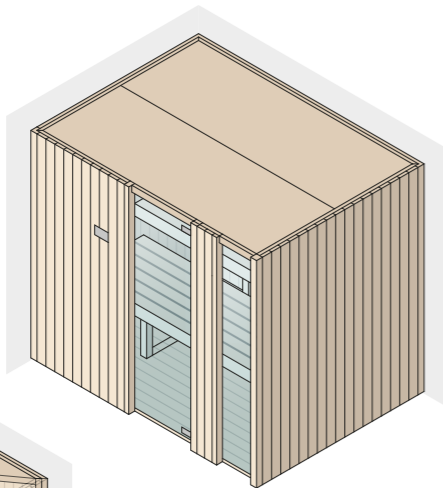
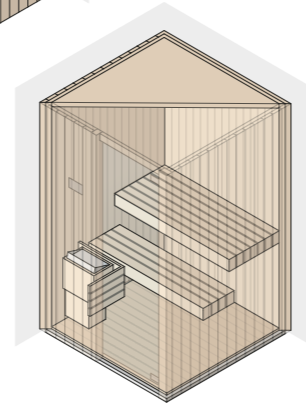
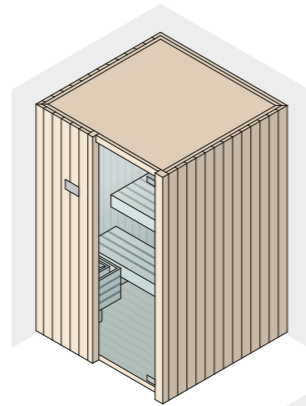



## Auki

Design: \_\_\_\_\_ Talocci Design

Costruita totalmente in legno pregiato di Abete di Svezia oppure Hemlock canadese senza nodi, Auki combina l'antica tradizione delle saune nordeuropee con un design moderno.

- › Sauna certificata IMQ, realizzata in legni pregiati e vetrate in cristalli temperati da 8 mm.
- › Pareti interne e esterne caratterizzate da doghe di larghezze variabili.
- › Auki si adatta facilmente alle necessità dello spazio a disposizione, anche per applicazioni su misura.

Built entirely from highly-prized Swedish pine or knot-free Canadian hemlock, Auki is the perfect blend of the ancient Scandinavian sauna tradition and up-to-the-minute design.

- › IMQ certified sauna made of highly-prized wood and 8mm toughened glass panels.
- › Inner and outer walls feature slats of variable width.
- › Auki can easily be adapted to fit the available space, also for made-to-measure solutions.





Finish: Canadian hemlock  
Optional: side glass panel







Finish: Swedish pine

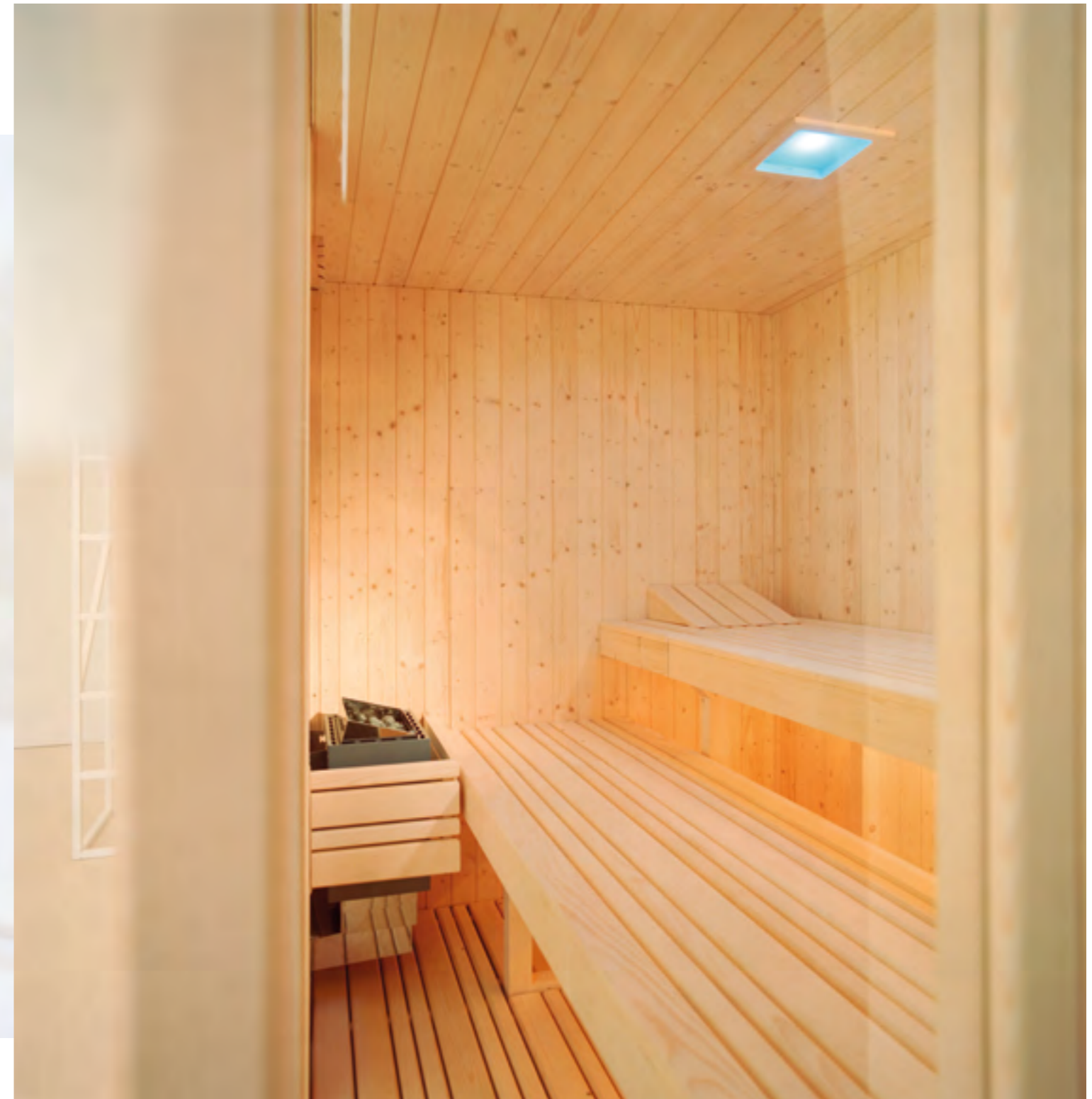

Auki / sauna /

## Materials



**Hemlock Canadese**  
Interno, esterno, arredi  
**Canadian Hemlock**  
Outside, inside, fittings

**Abete di Svezia**  
Interno, esterno, arredi  
**Swedish Fir Wood**  
Outside, inside, fittings

## Translations

### FRANÇAIS

#### Auki

Fabriqué entièrement en bois précieux de Pin finlandais ou Hemlock canadien sans nœuds, Auki combine l'ancienne tradition des saunas nord-européens avec un design moderne.

#### Caractéristiques :

Sauna certifié IMQ, réalisé en bois précieux et cloisons vitrées en cristal trempé à basse émission de 8 mm. Parois internes et externes caractérisées par des lattes de largeurs variables. Auki s'adapte facilement aux exigences de l'espace à disposition, également pour des applications sur mesure.

### DEUTSCH

#### Auki

Die gänzlich aus hochwertigem schwedische Fichtenholz oder astfreiem kanadischen Hemlock-Holz gebaute Auki kombiniert die antike Tradition der nordeuropäischen Saunen mit modernem Design.

#### Beschreibung:

Sauna mit IMQ-Zertifikat, gefertigt aus hochwertigen Hölzern und Verglasungen aus gehärtetem Niederemissionsglas, 8 mm.

Die Innen und Außenwände zeichnen sich durch unterschiedlich große Dauben aus.

Auki passt sich leicht dem zur Verfügung stehenden Raum an, auch für Anwendungen nach Maß.

### ESPAÑOL

#### Auki

Construida completamente con madera de calidad de Abeto finlandés o bien Hemlock canadiense sin nudos, Auki combina la antigua tradición de las saunas del norte de Europa con un diseño moderno.

#### Características:

Sauna certificada IMQ, realizada en maderas de calidad y paredes de vidrio en cristal templado de baja emisión de 8 mm.

Paredes internas y externas caracterizadas por tablas de anchuras variables.

Auki se adapta fácilmente a las necesidades del espacio a disposición, incluso en aplicaciones a medida.

### РУССКИЙ

#### Auki

Полностью выполненная из отборной финской ели или из канадского

хемлока без сучков, Auki являет собой гармоничное сочетание традиций финской сауны и современного дизайна.

#### Характеристики:

Сауна сертифицирована IMQ, она изготовлена из лучших сортов древесины и закаленного стекла 8 мм с низкой эмиссионной способностью.

Внутренние и внешние стены обшиты деревянными панелями различной ширины.

Auki легко подстраивается под имеющееся пространство, а также подлежит персонализации.

### 中文

#### Auki

完全采用芬兰珍贵的云杉木或加拿大无结铁杉木制成，Auki系列展现了北欧传统古老的桑拿浴与现代设计的完美结合。

#### 特点:

通过IMQ认证的整体桑拿房，使用珍贵的木材及经过淬火处理的低排放钢化玻璃，厚度为8mm。

内部及外部墙体可由不同宽度的木条组成，极具特色。

Auki 适用于已有空间的需求，也可根据实际情况提供尺寸定制。

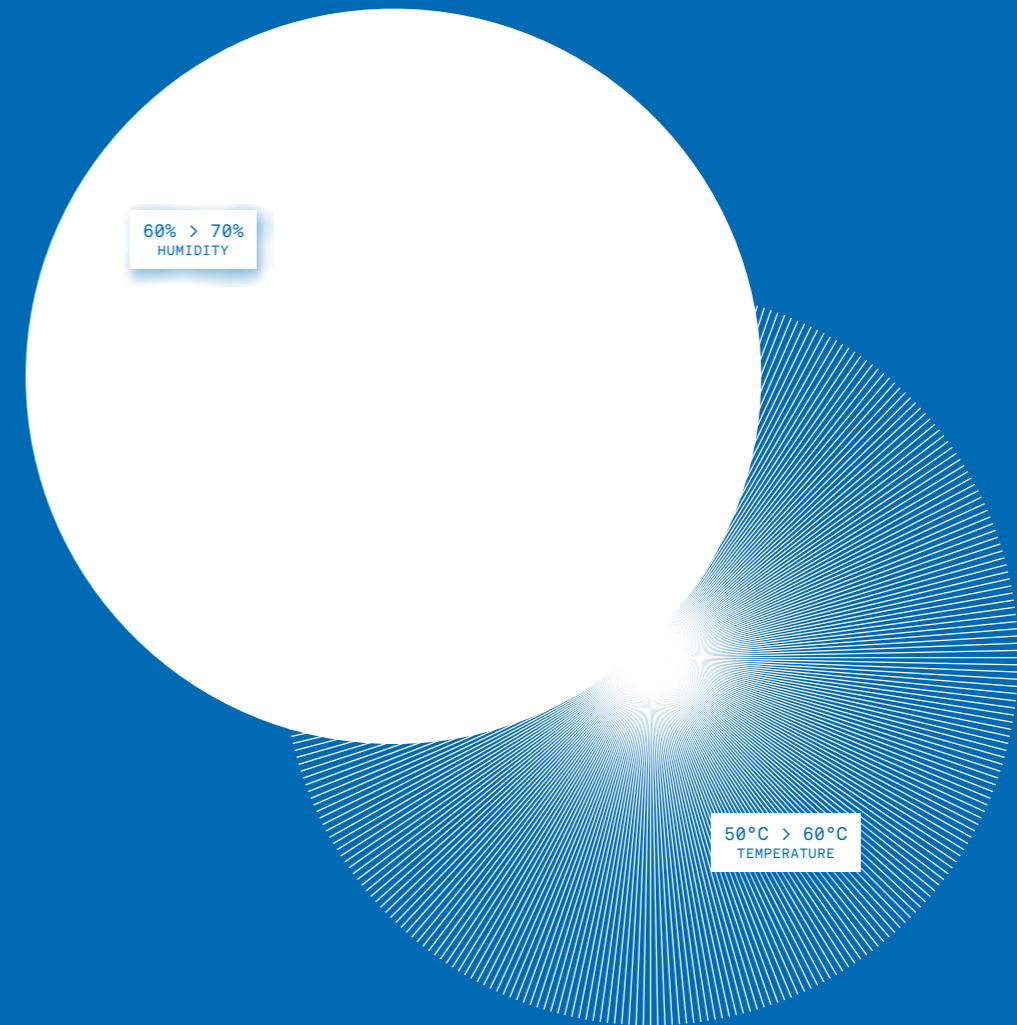

La Biosauna è una sauna con livelli di temperatura contenuti tra i 50 e i 60°C e un'umidità di circa 60-70%. Grazie al vaporizzatore integrato, impostando la temperatura preferita, la stufa Bio creerà l'equilibrio perfetto fra calore ed umidità. Il sistema combinato Effe consente la scelta tra Biosauna, un percorso a metà strada fra la sauna finlandese e la natura mediterranea del bagno di vapore, o sauna tradizionale, caratterizzata da temperature fino a 100°C con bassa umidità. Il sistema combinato può essere applicato a tutte le saune di Effe.

The Bio-sauna is a sauna whose temperature ranges from 50 to 60°C with humidity between 60-70%. The built-in vaporiser allows you to set your preferred temperature and the Bio heater creates the perfect balance between heat and humidity. The combined Effe system allows you to choose between a Bio-sauna, a halfway house between the Finnish sauna and the Mediterranean nature of the steam bath, or a traditional sauna with low humidity and a temperature of up to 100°C. This combined system can be installed in all Effe saunas.

# Bio-sauna

# LA SCELTA DI GENERATORI DI VAPORE EFFE

## YOUR CHOICE OF EFFE STEAM GENERATORS

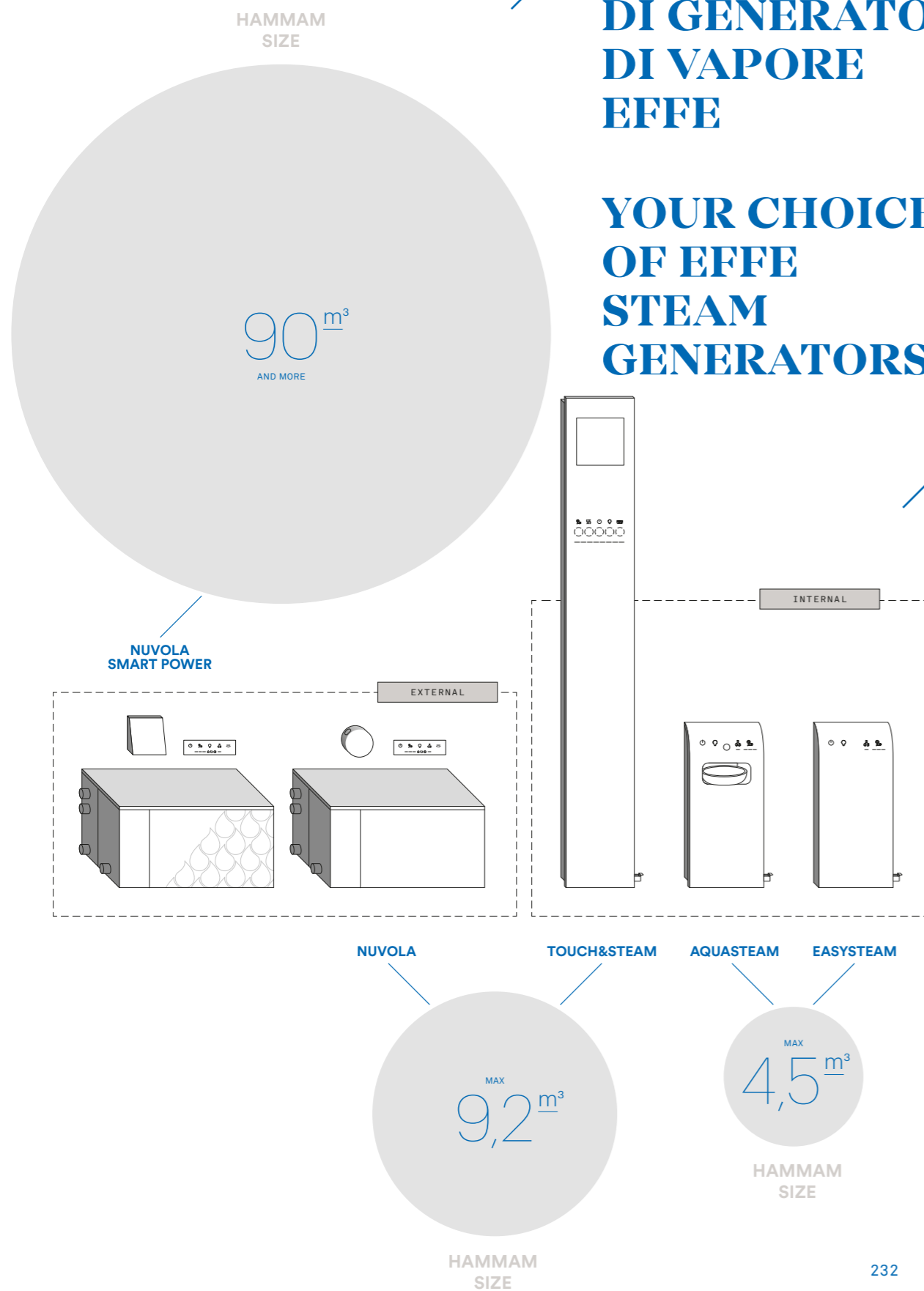

#### Materiali

Vetro temperato serigrafato.  
Alluminio verniciato RAL 9003.

#### Caratteristiche

Generatore di vapore interno.  
Sistema automatico di lavaggio caldaia.  
Sistema di regolazione portata acqua.  
Sistema automatico di scarico acqua.  
Funzione Energy Saver automatica.  
Pannello di controllo touch con icone retroilluminate e indicatore del livello di temperatura.  
Funzione Power Steam: sistema di diffusione vapore a ventilazione forzata.  
Funzione Caldo Doccia: sistema di riscaldamento a ventilazione forzata con funzione preriscaldamento.  
Vano contenitori per essenze.  
Illuminazione con cromoterapia a Led RGB, 5 colori fissi, 4 cicli dinamici e luce bianca.

#### ECC - Effe Comfort Control

Sistema che consente di gestire a distanza il bagno turco dal proprio dispositivo, tramite l'App Effegibi Experience. Disponibile su iOS.

#### ESS - Effe Sound System

Dispositivo con collegamento Bluetooth per l'ascolto di musica all'interno della sauna o dell'hammam.

#### Materials

Screen-printed tempered glass panel.  
Painted aluminium RAL 9003.

#### Features

Built in steam generator.  
Automatic boiler cleaning system.  
Water flow rate control system.  
Automatic water drainage system.  
Automatic energy saver function.  
Touch-screen control panel with backlit icons and temperature gauge.  
Power Steam Function: steam diffusion and forced ventilation heating system.  
Caldo Doccia Function: unit pre-heating function with forced ventilation heating system.  
Containers for essential oils.  
Lighting system with Led RGB chromotherapy 5 fixed colours, 4 dynamic cycles and white light.

#### ECC - Effe Comfort Control

System that remotely controls the steam bath from your device, using the Effegibi Experience app. Available on iOS.

#### ESS - Effe Sound System

Device with Bluetooth connection for listening to music inside the sauna or hammam.

#### Dimensioni

Dimensions  
23 x 3,7 x h 165 cm

#### Controcassa

Counterbox  
40 x 10 x h 173 cm

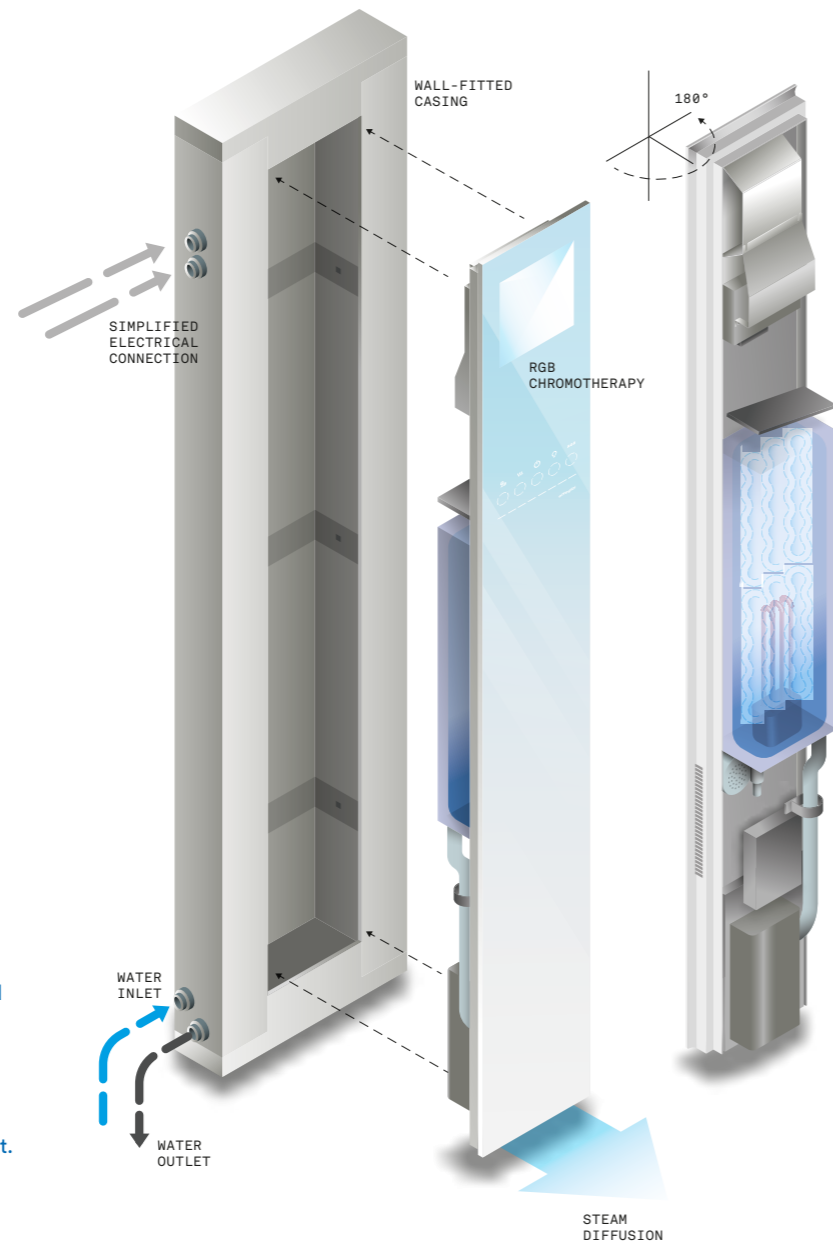

MODEL	POWER (KW)	VOLUME (M³)
30	3,0	0 - 3,5
45	4,5	3,5 - 4,5
60	6,0	4,5 - 6,2
90	9,0	6,2 - 9,2

## Touch&Steam

Inseribile in ogni doccia o ambiente hammam  
Touch&steam è un generatore professionale dal design elegante e leggero. Il massimo della tecnologia nella produzione di vapore.

- › Pannello di controllo touch con icone retroilluminate e indicatore del livello di temperatura.
- › Manutenzione ridotta grazie al sistema automatico di lavaggio della caldaia che minimizza l'accumulo di calcare.
- › Design elegante e compatto costituito da una lastra di vetro temperato serigrafato, spessore visibile: 3,7 cm.
- › PSF (Power Steam Function): innovativo sistema di ventilazione che minimizza la stratificazione delle temperature.

Touch&steam is a stylish, lightweight professional-standard generator that can be fitted to any shower or Hammam environment. State-of-the-art steam-generating technology.

- › Touch-screen control panel with backlit icons and temperature indicator.
- › Low maintenance thanks to the automatic boiler-cleaning system that minimises lime-scale build-up.
- › Stylish, compact design featuring a panel of silk-screen-printed toughened glass, visible thickness 3.7cm.
- › PSF (Power Steam Function): the innovative ventilation management system minimises temperature layering.





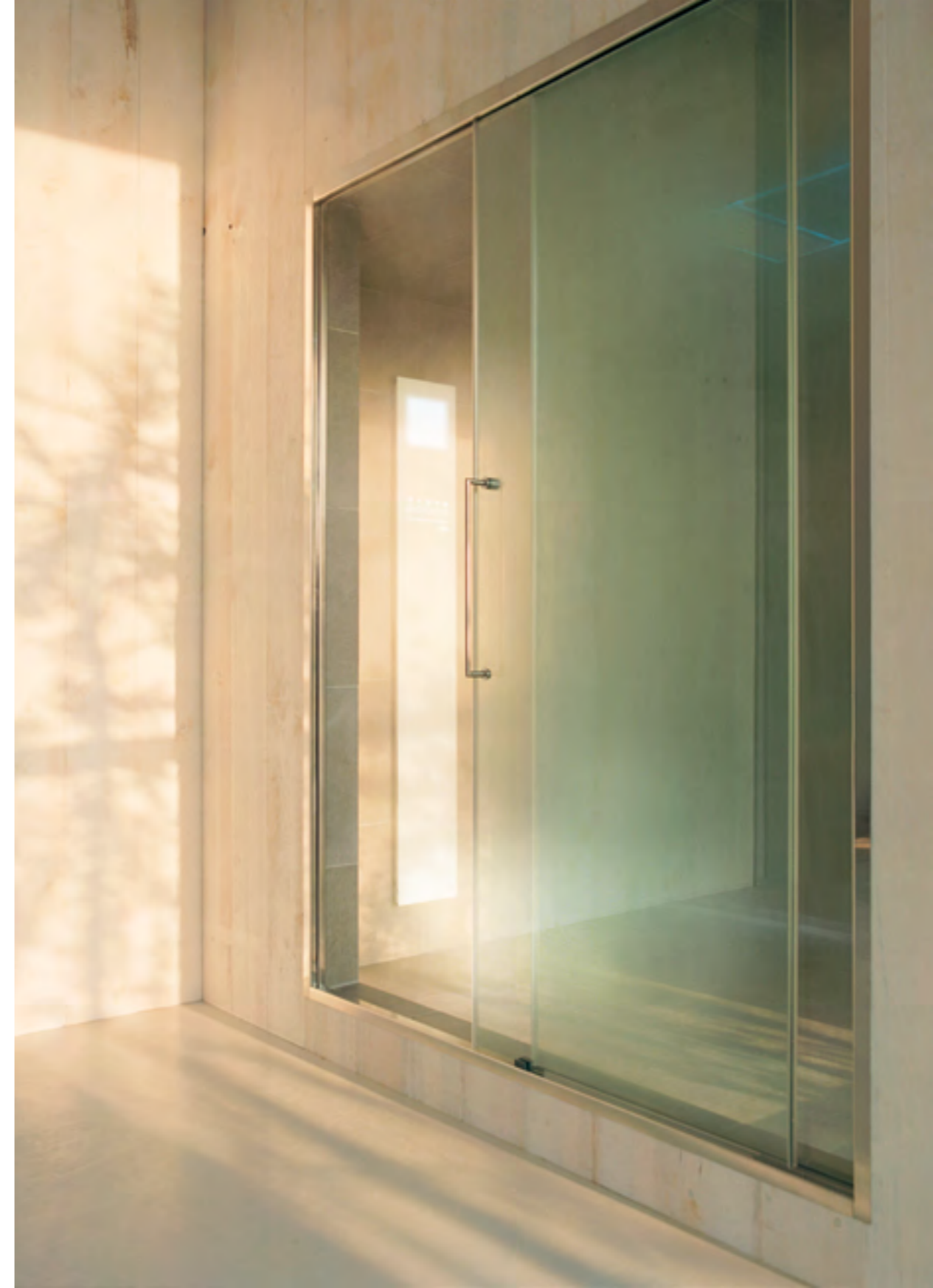





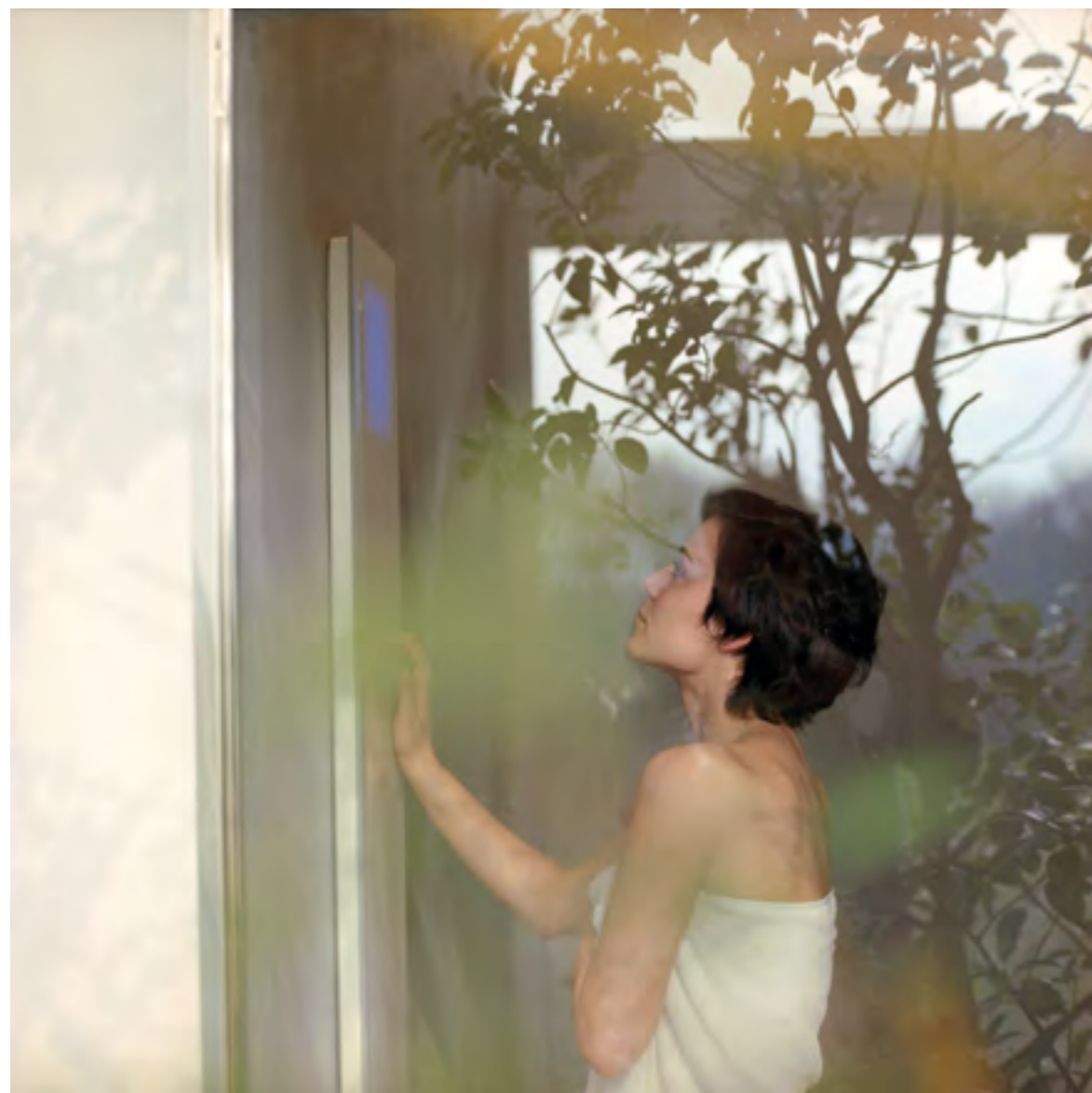

## Translations

### FRANÇAIS

#### Touch&Steam

Peut être inséré dans chaque douche ou hammam, Touch&Steam est un générateur de vapeur professionnel au design élégant et léger. Le maximum de la technologie dans la production de vapeur.

#### Caractéristiques :

Système de ventilation de l'air qui minimise la stratification des températures à l'intérieur de la cabine. Entretien réduit grâce au système automatique de lavage de la chaudière qui minimise l'accumulation de calcaire. Design élégant et compact composé d'un panneau vitré trempé sérigraphié, épaisseur visible : 3,7 cm. Tableau de commande tactile avec icônes rétro-illuminées et indicateur du niveau de température.

### DEUTSCH

#### Touch&Steam

Einsetzbar in jeder Dusche oder jedem Hamam-Bereich, Touch&Steam ist ein professioneller Generator im eleganten und leichten Design. Das Maximum der Technologie für die Dampfproduktion.

#### Beschreibung:

Ventilationssystem, das Temperaturschichten in der Kabine minimiert. Geringer Wartungsaufwand dank des automatischen Reinigungssystems des Heizkessels, das Kalkansammlungen minimiert. Elegantes und kompaktes Design bestehend aus einer gehärteten siebbedruckten Glasscheibe, sichtbare Dicke: 3,7 cm. Touch-Bedienpaneel mit rückbeleuchteten Icons und Temperaturanzeige.

### ESPAÑOL

#### Touch&Steam

El Touch&Steam, un generador de vapor profesional de diseño elegante y ligero, se puede acoplar a todas las duchas o ambientes hammam.

#### Características:

Sistema de ventilación del aire que reduce al mínimo la estratificación de las temperaturas en el interior de la cabina. Mantenimiento reducido gracias al sistema automático de lavado de la caldera que reduce al mínimo la acumulación de cal. Diseño elegante y compacto formado por una placa de vidrio templado serigrafiado, con un grosor visible de 3,7 cm. Panel de control touch con iconos retroiluminados e indicador del nivel de temperatura.

### РУССКИЙ

#### Touch&Steam

Профессиональный парогенератор Touch&steam отличается легким и элегантным дизайном, который будет уместен и в душевой кабине, и в более просторной парной. Самая лучшая технология производства пара.

#### Характеристики:

Система вентиляции оптимизирует равномерное распределение температуры внутри кабины. Система автоматической очистки нагревателя позволяет избежать образования накипи и частого обслуживания устройства. Современный минималистичный дизайн из закаленного стекла с шелкографией толщиной 3,7 см. Сенсорная панель управления с символами с задней подсветкой и индикатором температуры.

### 中文

#### Touch&Steam

可安装在任何淋浴间或蒸汽室的 Touch&steam蒸汽发生器，是一款设计优雅而轻盈的专业蒸汽设备，是当今生产蒸汽的最先进技术。

#### 特点:

空气推送系统可以保证蒸汽房内的温度平均分布。锅炉自动清洗功能可以降低维护频率，以及减少石灰石的生成与堆积。设计优雅而紧凑，仅由一块丝网钢化玻璃面板制成，可见厚度仅为3.7cm。触摸式控制面板，配置背光式图标以及温度指示器。

#### Materiali

Vetro curvato serigrafato.  
Alluminio verniciato RAL 9003.

#### Caratteristiche

Generatore di vapore interno.  
Sistema automatico di lavaggio caldaia.  
Sistema di regolazione portata acqua.  
Sistema automatico di scarico acqua.  
Funzione Energy Saver automatica.  
Pannello di controllo touch con icone retroilluminate e indicatore del livello di temperatura.  
Fonte a caduta con erogazione acqua controllata e retroilluminata.  
Ciotola in resina bianca.  
Contenitori per essenze.

#### ECC - Effe Comfort Control

Sistema che consente di gestire a distanza il bagno turco dal proprio dispositivo, tramite l'App Effegibi Experience. Disponibile su iOS.

#### Materials

Curved silk-screen printed glass panel.  
Painted aluminium RAL 9003.

#### Features

Built in steam generator.  
Automatic boiler cleaning system.  
Water flow rate control system.  
Automatic water drainage system.  
Automatic Energy Saver Function.  
Touch-screen control panel with backlit icons and temperature gauge.  
Waterfall spring with controlled backlit water flow.  
Bowl in white resin.  
Containers for essential oils.

#### ECC - Effe Comfort Control

System that remotely controls the steam bath from your device, using the Effegibi Experience app. Available on iOS.

#### Dimensioni

Dimensions  
25 x 3,7 x h 57 cm

#### Controcassa

Counterbox  
37 x 10 x h 54 cm

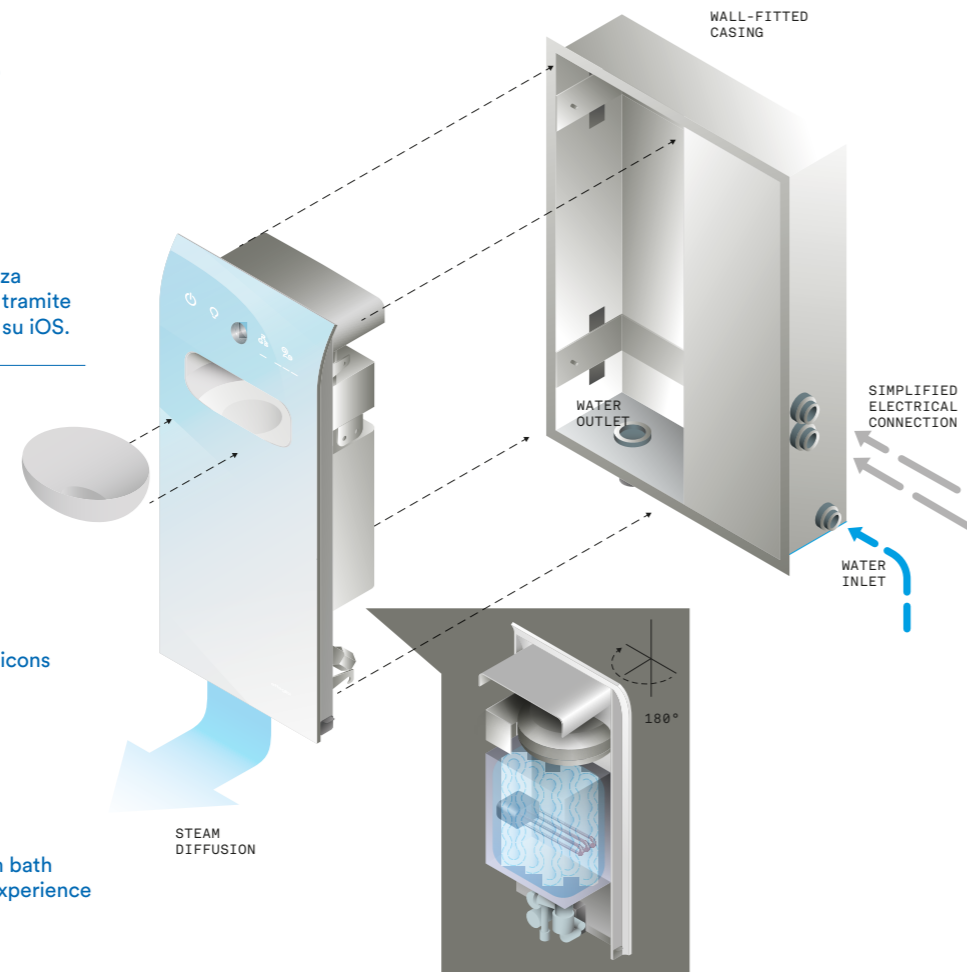

MODEL	POWER (KW)	VOLUME (M³)
30	3,0	0 - 3,5
45	4,5	3,5 - 4,5

## Aquasteam

Una lastra di vetro curvato con comandi digitali, una fonte e una ciotola rendono Aquasteam un generatore di vapore intuitivo nell'uso e perfettamente abbinabile a qualsiasi rivestimento.

- › Tecnologia Effe per la generazione del vapore: igiene, controllo del calcare e massima qualità del vapore.
- › Manutenzione ridotta e lunga durata grazie al sistema automatico di lavaggio della caldaia.
- › Design molto compatto costituito da una lastra di vetro curvato serigrafato, spessore visibile: 3,7 cm.
- › Predisposizione per collegamento a lampada con luce bianca o cromoterapia.
- › Pannello di controllo touch con icone retroilluminate e indicatore del livello di temperatura.

A curved glass panel with digital controls, a spring and a bowl make Aquasteam an intuitive steam generator to use that blends perfectly with any décor.

- › Effe steam generation technology gives you maximum control over hygiene, lime-scale build-up and steam quality.
- › Low maintenance and a long life thanks to the automatic boiler-cleaning system.
- › Extremely compact design featuring a curved panel of silk-screen-printed glass, visible thickness 3.7cm.
- › Set up for connection to a white or chromotherapy light fitting.
- › Touch-screen control panel with backlit icons and temperature indicator.







Aquasteam is equipped with a cool water spring operated by a practical touch-screen control. The holder for essential oils at the bottom allows you to recreate your favourite aroma therapy experience.





## Translations

### FRANÇAIS

#### Aquasteam

Un panneau vitré incurvé équipé de commandes tactiles, une fontaine et un bol font d'Aquasteam un générateur de vapeur à l'usage intuitif que l'on peut parfaitement combiner avec tout type de revêtement.

#### Caractéristiques :

Technologie Effe pour la production de vapeur : hygiène, contrôle du calcaire et qualité maximale de la vapeur.  
Entretien réduit et durée accrue grâce au système automatique de lavage de la chaudière.  
Design très compact composé d'un panneau vitré incurvé sérigraphié, épaisseur visible : 3,7 cm.  
Tableau de commande tactile avec icônes rétro-illuminées et indicateur du niveau de température.  
Pré-installation pour raccordement de la lampe pour chromothérapie.

### DEUTSCH

#### Aquasteam

Eine kurvige Glasscheibe mit digitalen Bedienelementen, die Quelle und eine Schale machen aus Aquasteam einen anwendungsfreundlichen Dampfgenerator, der perfekt zu jeder Verkleidung passt.

#### Beschreibung:

Effe-Technologie für die Dampferzeugung: Hygiene, Kalkkontrolle und maximale Dampfqualität.  
Geringer Wartungsaufwand und lange Lebensdauer dank des automatischen Reinigungssystems des Heizkessels.  
Sehr kompaktes Design bestehend aus einer kurvigen siebbedruckten Glasscheibe, sichtbare Dicke: 3,7 cm.  
Touch-Bedienpaneel mit rückbeleuchteten Icons und Temperaturanzeige.  
Vorrüstung für den Anschluss an eine Farblichttherapie-Lampe.

### ESPAÑOL

#### Aquasteam

Una placa de vidrio curvada con controles digitales, una fuente y un cuenco hacen de Aquasteam un generador de vapor intuitivo en el uso y que se puede combinar perfectamente con cualquier revestimiento.

#### Características:

Tecnología Effe para la generación del vapor: higiene, control de la cal y máxima calidad del vapor.  
Mantenimiento reducido y larga duración gracias al sistema automático de lavado de la caldera.  
Diseño muy compacto formado por una placa de vidrio curvado serigrafado con un grosor visible de 3,7 cm.  
Panel de control touch con iconos retroiluminados e indicador del nivel de temperatura.  
Predisposición para conexión a lámpara para cromoterapia.

### РУССКИЙ

#### Aquasteam

Парогенератор Aquasteam представляет собой изогнутую стеклянную панель с интуитивным цифровым управлением, умывальником и чашей. Aquasteam отлично гармонирует с любым стилем душевой кабины.

#### Характеристики:

Технология парогенерации от Effe: защита от накипи и максимально качественный пар.  
Благодаря функции автоматической очистки нагревателя парогенератор работает дольше и не требует частого обслуживания.  
Современный минималистичный дизайн из изогнутого стекла с шелкографией толщиной 3,7 см.  
Сенсорная панель управления с символами с задней подсветкой и индикатором температуры.  
Возможность подключения светильника с функцией хромотерапии.

### 中文

#### Aquasteam

一块弧形折弯的玻璃触控面板，水流及水钵的配置使得Aquasteam系列蒸汽发生器更加实用且操作便捷，可与任意外饰面完美搭配。

#### 特点:

Effe技术研发的蒸汽发生器：严格控制蒸汽的质量、浓度及清洁度。  
锅炉自动清洗功能可以降低维护频率并延长使用寿命。  
设计优雅而紧凑，仅由一块丝网钢化玻璃面板制成，可见厚度仅为3.7cm。  
触摸式控制面板，配置背光式图标以及温度指示器。  
预留彩色光谱疗法系统选配连接接口。

#### Materiali

Vetro curvato serigrafato.  
Alluminio verniciato RAL 9003.

#### Caratteristiche

Generatore di vapore interno.  
Sistema automatico di lavaggio caldaia.  
Sistema di regolazione portata acqua.  
Sistema automatico di scarico acqua.  
Funzione Energy Saver automatica.  
Pannello di controllo touch con icone retroilluminate e indicatore del livello di temperatura.  
Contenitori per essenze.

#### ECC - Effe Comfort Control

Sistema che consente di gestire a distanza il bagno turco dal proprio dispositivo, tramite l'App Effegibi Experience. Disponibile su iOS.

#### Materials

Curved silk-screen printed glass panel.  
Painted aluminium RAL 9003.

#### Features

Built in steam generator.  
Automatic boiler cleaning system.  
Water flow rate control system.  
Automatic water drainage system.  
Automatic Energy Saver Function.  
Touch-screen control panel with backlit icons and temperature gauge.  
Containers for essential oils.

#### ECC - Effe Comfort Control

System that remotely controls the steam bath from your device, using the Effegibi Experience app. Available on iOS.

**Dimensioni**  
**Dimensions**  
25 x 3,7 x h 57 cm

**Controcassa**  
**Counterbox**  
37 x 10 x h 54 cm

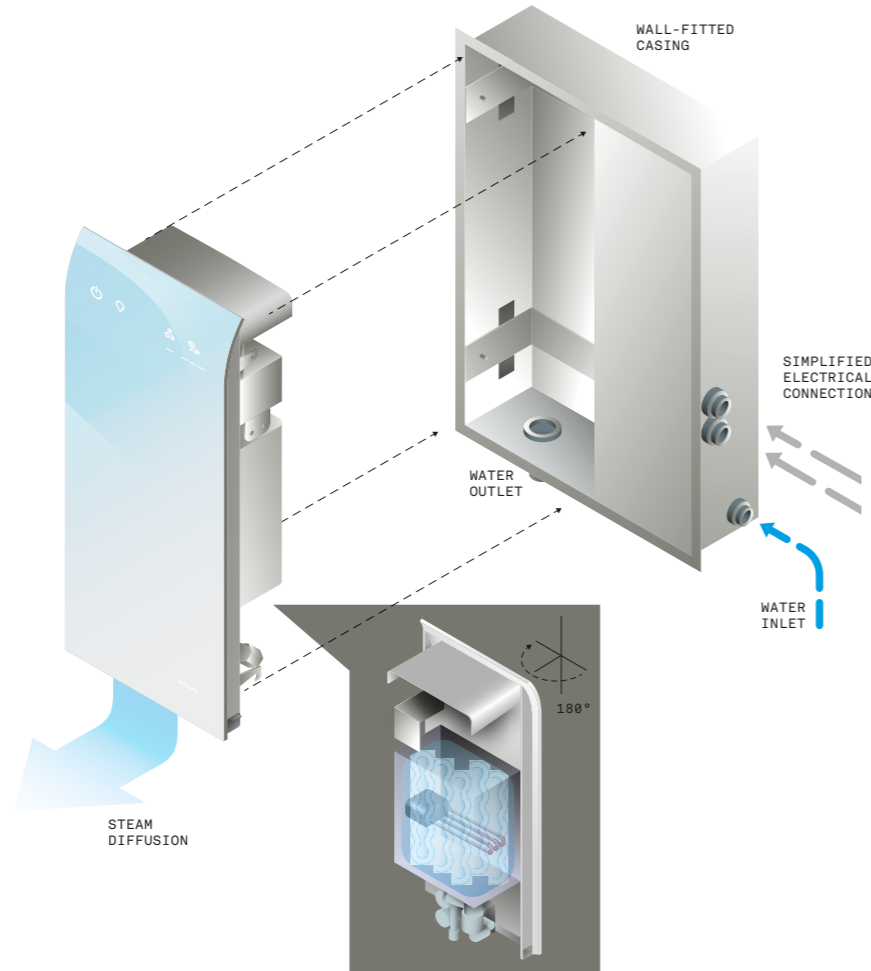

MODEL	POWER (KW)	VOLUME (M <sup>3</sup> )
30	3,0	0 - 3,5
45	4,5	3,5 - 4,5

## Easystem

Generatore di vapore elegante e compatto, Easystem abbina la semplicità di installazione, elevata tecnologia e semplicità di utilizzo.

- › Tecnologia Effe per la generazione del vapore: igiene, controllo del calcare e massima qualità del vapore.
- › Manutenzione ridotta e lunga durata grazie al sistema automatico di lavaggio della caldaia.
- › Design molto compatto costituito da una lastra di vetro curvato serigrafato, spessore visibile: 3,7 cm.
- › Predisposizione per collegamento a lampada con luce bianca o cromoterapia.
- › Pannello di controllo touch con icone retroilluminate e indicatore del livello di temperatura.

A stylish, compact steam generator, Easystem is easy to install, high-tech and user-friendly.

- › Effe steam generation technology gives you maximum control over hygiene, lime-scale build-up and steam quality.
- › Low maintenance and a long life thanks to the automatic boiler-cleaning system.
- › Extremely compact design featuring a curved panel of silk-screen-printed glass, visible thickness 3.7cm.
- › Set up for connection to a white or chromotherapy light fitting.
- › Touch-screen control panel with backlit icons and temperature indicator.





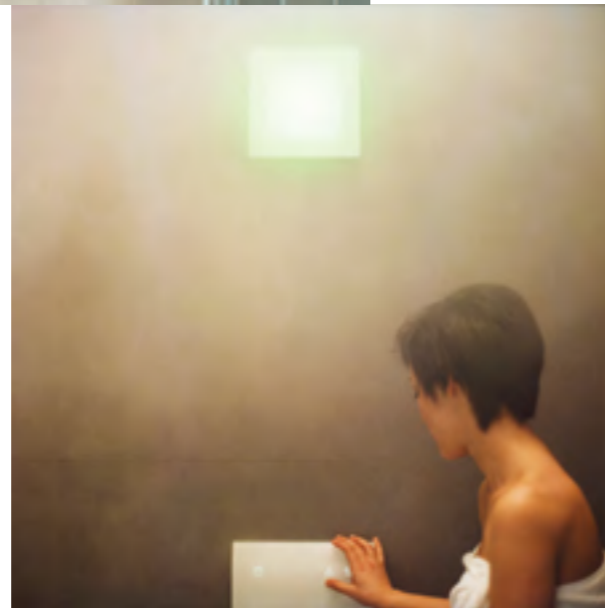

Touch-screen control panels with backlit icons and temperature indicator (optional).

Easystem has a container for essential oils at the side, for an inebriant aroma-therapy experience.





## Translations

### FRANÇAIS

#### Easystem

Générateur de vapeur élégant et compact, Easystem conjugue la simplicité d'installation, la technologie élevée et la simplicité d'utilisation.

#### Caractéristiques :

Technologie Effe pour la production de vapeur : hygiène, contrôle du calcaire et qualité maximale de la vapeur.  
Entretien réduit et durée accrue grâce au système automatique de lavage de la chaudière.  
Design très compact composé d'un panneau vitré incurvé sérigraphié, épaisseur visible : 3,7 cm.  
Tableau de commande tactile avec icônes rétro-illuminées et indicateur du niveau de température.  
Pré-installation pour raccordement de la lampe pour chromothérapie.

### ESPAÑOL

#### Easystem

Generador de vapor elegante y compacto, Easystem combina sencillez de instalación, elevada tecnología y sencillez de uso.

#### Características:

Tecnología Effe para la generación del vapor: higiene, control de la cal y máxima calidad del vapor.  
Mantenimiento reducido y larga duración gracias al sistema automático de lavado de la caldera.  
Diseño muy compacto formado por una placa de vidrio curvado serigrafiado, con un grosor visible de 3,7 cm.  
Panel de control touch con iconos retroiluminados e indicador del nivel de temperatura.  
Predisposición para conexión a lámpara para cromoterapia.

### 中文

#### Easystem

一款设计优雅而结构紧凑的蒸汽发生器，Easystem系列安装简单，技术先进，使用方便。

#### 特点:

Effe技术研发的蒸汽发生器：严格控制蒸汽的质量、浓度及清洁度。  
锅炉自动清洗功能可以降低维护频率并延长使用寿命。  
设计优雅而紧凑，仅由一块丝网钢化玻璃面板制成，可见厚度仅为3.7cm。  
触摸式控制面板，配置背光式图标以及温度指示器。  
预留彩色光谱疗法系统选配连接口。

### DEUTSCH

#### Easystem

Eleganter und kompakter Dampfgenerator, Easystem vereint in sich eine einfache Installation, hochwertige Technologie und eine einfache Benutzung.

#### Beschreibung:

Effe-Technologie für die Dampferzeugung: Hygiene, Kalkkontrolle und maximale Dampfqualität.  
Geringer Wartungsaufwand und lange Lebensdauer dank des automatischen Reinigungssystems des Heizkessels.  
Sehr kompaktes Design bestehend aus einer kurvigen siebbedruckten Glasscheibe, sichtbare Dicke: 3,7 cm.  
Touch-Bedienpaneel mit rückbeleuchteten Icons und Temperaturanzeige.  
Vorrüstung für den Anschluss an eine Farblichttherapie-Lampe.

### РУССКИЙ

#### Easystem

Компактный и элегантный парогенератор Easystem сочетает простоту установки, высокотехнологичность и легкость эксплуатации.

#### Характеристики:

Технология парогенерации от Effe: защита от накипи и максимальное качество пара.  
Благодаря функции автоматической очистки нагревателя парогенератор работает дольше и не требует частого обслуживания.  
Современный минималистичный дизайн из изогнутого стекла с шелкографией толщиной 3,7 см.  
Сенсорная панель управления с символами с задней подсветкой и индикатором температуры.  
Возможность подключения светильника с функцией хромотерапии.

#### Caratteristiche generatore di vapore

RWF Regulating Water Flow: autoregolazione alla pressione dell'impianto idrico.  
SWF Smart Water Filling: gestione ottimizzata di riempimento caldaia.  
SBC Smart Boiler Cleaning: diluizioni e risciacqui intermedi sul reale fabbisogno.  
SEC Smart Energy Control: distribuzione uniforme nel tempo, dei cicli di accensione e spegnimento delle termoresistenze.  
ODS Open Door Sensor: sensore porta aperta.  
Pannello di controllo touch con icone retroilluminate e indicatore del livello di temperatura.

#### Caratteristiche diffusore di vapore

Alette orientabili per direzionare il vapore.  
Sistema di ricircolo dell'aria in cabina con ventilatore water resistant.  
Contenitore per essenze.  
Led luminoso all'uscita del vapore.  
Sonda di temperatura aggiuntiva.

#### ECC - Effe Comfort Control

Sistema che consente di gestire a distanza il bagno turco dal proprio dispositivo, tramite l'App Effegibi Experience. Disponibile su iOS.

#### Steam generator features

RWF Regulating water flow: can work on a wide range of water systems with different pressures.  
SWF Smart Water Filling: optimised management of boiler filling.  
SBC Smart Boiler Cleaning: dilution and intermediate rinsing processes not time controlled but based on real need.  
SEC Smart Energy Control: evenly spaced on/off periods for the heating elements.  
ODS Open Door Sensor.  
Touch-screen control panel with backlit icons and temperature gauge.

#### Steam diffuser features

Adjustable flaps to control the outgoing steam direction.  
Cubicle air-recirculation system built into the water-resistant fan.  
Essential oils container.  
Steam output Led light.  
Additional temperature probe inside the diffuser.

#### ECC - Effe Comfort Control

System that remotely controls the steam bath from your device, using the Effegibi Experience app. Available on iOS.

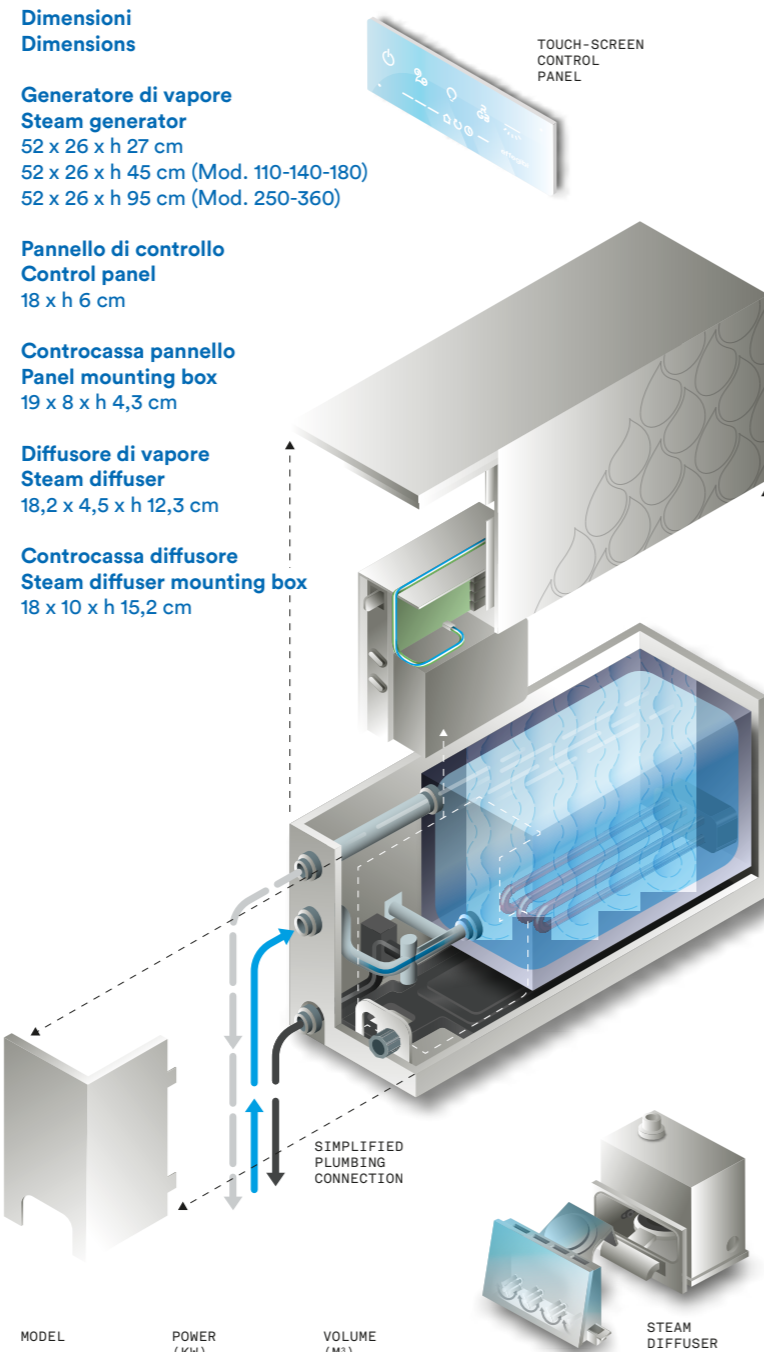

MODEL	POWER (KW)	VOLUME (M <sup>3</sup> )
25	2,5	0 - 2,5
30	3,0	2,5 - 3,5
45	4,5	3,5 - 4,5
55	5,5	4,5 - 5,5
70	7,0	5,5 - 7,2
90	9,0	7,2 - 9,2
110	11,0	9,2 - 12,0
140	14,0	12,0 - 15,0
180	18,0	15,0 - 25,0
250	25,0	25,0 - 35,0
360	36,0	35,0 - 50,0

## Nuvola Smart Power

Generatore di vapore ad alta potenza, da collocare all'esterno dello spazio hammam: la più sofisticata tecnologia esistente e la pulizia formale fanno Nuvola Smart Power un prodotto senza rivali.

- › Generatore di vapore professionale esterno, adatto per ampie cubature.
- › È stato testato fino a 3.000 ore di funzionamento senza bisogno di manutenzione.
- › Nuvola Smart Power è adatto per applicazioni a scomparsa e si integra quindi facilmente con qualsiasi soluzione d'arredo.
- › Controllo automatico delle termoresistenze per una distribuzione di vapore uniforme nel tempo.
- › PSF (Power Steam Function): innovativo sistema di ventilazione che minimizza la stratificazione delle temperature.

A high-power steam generator, to be fitted outside the Hammam space. The most sophisticated technology in existence and its clean lines make Nuvola Smart Power an unrivalled product.

- › External professional-standard steam generator suitable for large spaces.
- › Tested for up to 3,000 maintenance-free operating hours.
- › Nuvola Smart Power has been developed for hidden installation, to blend perfectly with any interior design solution.
- › Automatic heating element control for even steam distribution over time.
- › PSF (Power Steam Function): the innovative ventilation management system minimises temperature layering.







Hamam with Nuvola Smart Power  
and Tuttovetro Inside door with built-in frame.





## Translations

### FRANÇAIS

#### Nuvola Smart Power

Générateur de vapeur à haute puissance, à placer à l'extérieur de l'espace hammam : la technologie la plus sophistiquée existante et la netteté formelle font de Nuvola Smart Power un produit exceptionnel.

#### Caractéristiques :

Générateur de vapeur professionnel externe, indiqué pour d'amples cubages.  
 3 000 heures de fonctionnement garanties sans besoin d'entretien  
 Fonction ODS (Open Door Sensor) : le générateur bloque la production de vapeur s'il relève que la porte est ouverte.  
 Contrôle automatique des thermorésistances pour une distribution de vapeur uniforme dans le temps.  
 Nuvola Smart Power est indiqué pour des solutions à encastrer et permet l'application dans des espaces réalisés sur mesure.

### DEUTSCH

#### Nuvola Smart Power

Hochleistungsdampfgenerator, der außerhalb des Hamams montiert wird: modernste Technologie und klare Linien machen aus Nuvola Smart Power ein konkurrenzloses Produkt.

#### Beschreibung:

Professioneller außenseitiger Dampfgenerator für große Volumen.  
 Garantierte 3000 Betriebsstunden ohne Wartungsbedarf.  
 Funktion ODS (Open Door Sensor): bei offenstehender Tür sperrt der Generator die Dampferzeugung.  
 Automatische Ansteuerung der Heizwiderstände für eine dauerhaft gleichmäßige Dampfverteilung.  
 Nuvola Smart Power eignet sich für Einbaulösungen und kann daher in nach Maß gefertigten Räumen eingesetzt werden.

### ESPAÑOL

#### Nuvola Smart Power

Generador de vapor de potencia elevada, a colocar en el exterior del espacio hammam: la tecnología existente más sofisticada y la limpieza formal convierten Nuvola Smart Power en un producto sin igual.

#### Características:

Generador de vapor profesional externo, adecuado para amplios espacios.  
 3000 horas garantizadas de funcionamiento sin necesidad de mantenimiento.  
 Función ODS (Open Door Sensor): el generador bloquea la producción de vapor si detecta que la puerta está abierta.  
 Control automático de las termorresistencias para una distribución de vapor uniforme en el tiempo.  
 Nuvola Smart Power es adecuado para soluciones empotrables y por tanto permite la aplicación en espacios realizados a medida.

### РУССКИЙ

#### Nuvola Smart Power

Парогенератор, которому нет равных. Предназначенный для размещения вне кабины хаммама, парогенератор Nuvola Smart Power – это самая мощная и изощренная на сегодняшний день технология парогенерации в элегантном и лаконичном облачении.

#### Характеристики:

Профессиональный парогенератор для установки за пределами хаммама, пригодный для просторных помещений.  
 Гарантия 3000 часов работы без техобслуживания.  
 Функция ODS (Open Door Sensor): парогенератор останавливает выработку пара при открытой двери.  
 Автоматический контроль ТЭНов для равномерного распределения пара во времени.  
 Nuvola Smart Power идеально подходит для встроенных решений и для разработки индивидуальных проектов.

### 中文

#### Nuvola Smart Power

高功率蒸汽发生器，需放置于土耳其浴室外部：成熟的先进技术及自动清洁功能，使得Nuvola Smart Power系列蒸汽发生器在同类产品中占据遥遥领先的地位。

#### 特点:

适用于大范围空间的专业外置蒸汽发生器。  
 保证3000小时运行无需进行产品维护。  
 ODS开门感应功能：如果检测到蒸汽门处于打开状态，蒸汽发生器将会自动停止产生蒸汽。  
 自动热阻控制功能，可保证长时间使用过程中蒸汽的均匀分布。  
 Nuvola Smart Power 系统也适用于在墙体预埋起来，因此可以按照实际空间大小提供定制化解决方案。

#### Caratteristiche generatore di vapore

RWF Regulating Water Flow: autoregolazione alla pressione dell'impianto idrico.  
SWF Smart Water Filling: gestione ottimizzata di riempimento caldaia.  
SBC Smart Boiler Cleaning: diluizioni e risciacqui intermedi sul reale fabbisogno.  
Pannello di controllo touch con icone retroilluminate e indicatore del livello di temperatura.

#### Caratteristiche diffusore di vapore

Contenitore per essenze.

#### Steam generator features

RWF Regulating water flow: can work on a wide range of water systems with different pressures.  
SWF Smart Water Filling: optimised management of boiler filling.  
SBC Smart Boiler Cleaning: dilution and intermediate rinsing processes not time controlled but based on real need.  
Panel with backlit icons and temperature gauge.

#### Steam diffuser features

Essential oils container.

#### Dimensioni Dimensions

**Generatore di vapore  
Steam generator**  
52 x 26 x h 27 cm

**Pannello di controllo  
Control panel**  
16,5 x h 5 cm

**Controcassa pannello  
Panel mounting box**  
16 x 7 x h 4,5 cm

**Diffusore di vapore  
Steam diffuser**  
Ø 7 cm - h 3,5 cm

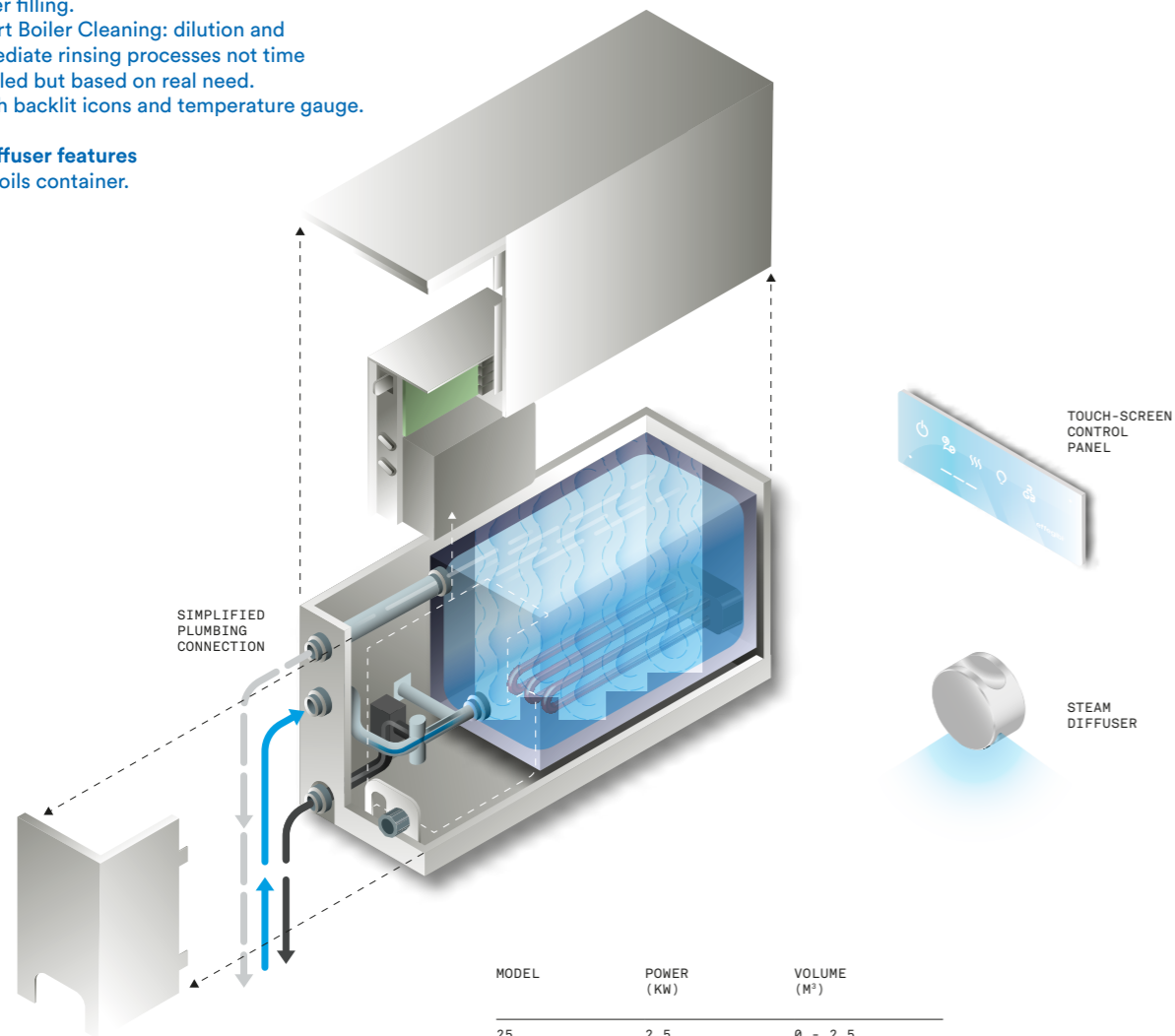

MODEL	POWER (KW)	VOLUME (M <sup>3</sup> )
25	2,5	0 - 2,5
30	3,0	2,5 - 3,5
45	4,5	3,5 - 4,5
55	5,5	4,5 - 5,5
70	7,0	5,5 - 7,2
90	9,0	7,2 - 9,2

## Nuvola

Nuvola è un generatore di vapore esterno, adatto per applicazioni a scomparsa: si integra quindi facilmente con qualsiasi soluzione d'arredo. Semplicità e affidabilità al servizio del tuo benessere.

- › Generatore di vapore professionale esterno, per cubature fino a 9,2 m<sup>3</sup>.
- › Controllo automatico delle termoresistenze per una distribuzione di vapore uniforme nel tempo.
- › La tecnologia di controllo del vapore assicura igiene e purificazione dal calcare.

Nuvola is an external steam generator which has been designed for concealed installations and therefore blends in perfectly with any interior design. Simplicity and reliability for your wellbeing.

- › Professional external steam generator, for volumes up to 9.2 m<sup>3</sup>.
- › Automatic heating element control for even steam distribution over time.
- › The steam-control technology ensures excellent hygiene and no lime-scale build-up.



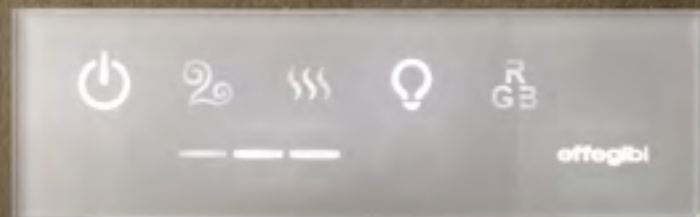

## Translations

### FRANÇAIS

#### Nuvola

Nuvola est un générateur de vapeur externe, adapté pour des applications escamotables et s'intègre donc facilement à toutes les solutions d'ameublement. Simplicité et fiabilité au service de votre bien-être.

#### Caractéristiques :

Générateur de vapeur professionnel externe, pour des cubages jusqu'à 9,2 m<sup>3</sup>.

Contrôle automatique des thermorésistances pour une distribution de vapeur uniforme dans le temps.

La technologie de contrôle de la vapeur garantit hygiène et purification du calcaire.

### ESPAÑOL

#### Nuvola

Nuvola es un generador de vapor externo, adecuado para aplicaciones ocultas y se integra por tanto fácilmente con cualquier solución de mobiliario. Sencillez y fiabilidad al servicio de tu bienestar.

#### Características:

Generador de vapor profesional externo, adecuado para espacios de hasta 9,2 m<sup>3</sup>.

Control automático de las termorresistencias para una distribución de vapor uniforme en el tiempo.

La tecnología de control del vapor asegura higiene y depuración de la cal.

### 中文

#### Nuvola

Nuvola 是一款外部蒸汽发生器，针对隐藏式安装进行了特别设计，因此可以与室内环境完美融合。设计简约、品质可靠，有助身心健康。

#### 特点:

专业外部蒸汽发生器，适用于体积不超过9.2立方米的浴室。

自动热阻控制功能，可保证长时间使用过程中蒸汽的均匀分布。

蒸汽控制技术确保设备卫生，而且不会积聚水垢。

### DEUTSCH

#### Nuvola

Nuvola ist ein außenseitiger Dampfgenerator für verdeckte Anwendungen und fügt sich daher leicht in jede Einrichtungsgestaltung ein. Einfachheit und Zuverlässigkeit im Dienst Ihres Wohlbefindens.

#### Beschreibung:

Professioneller außenseitiger Dampfgenerator für Volumen bis zu 9,2 m<sup>3</sup>.

Automatische Ansteuerung der Heizwiderstände für eine dauerhaft gleichmäßige Dampfverteilung.

Die Technologie für die Dampfsteuerung garantiert Hygiene und Kalkfreiheit.

### РУССКИЙ

#### Nuvola

Nuvola – это парогенератор внешней установки, который идеально подходит для скрытого монтажа, благодаря чему легко интегрируется в любой интерьер. Простота и надежность для Вашего спа-отдыха.

#### Характеристики:

Профессиональный парогенератор внешней установки для помещений объемом до 9,2 м<sup>3</sup>.

Автоматический контроль ТЭНов для равномерного распределения пара во времени.

Технология контроля пара обеспечивает гигиену и очистку от накипи.

**Finiture**

Cromato.  
Acciaio spazzolato.

**Soffione multifunzione**

Soffione da soffitto con funzioni pioggia, cascata, nebulizzazione.

Luce bianca.

Cromoterapia (Rosso, Blu, Verde, Giallo) e programma "Feel".

Miscelatore termostatico 3/4" incasso con deviatore 3 vie.

Pannello di controllo touch con icone retroilluminate per la gestione di tutte le funzioni (doccia, vapore, luce).

Completo doccia con on/off automatico.

**Dimensioni****Dimensions****Soffione**

**Shower head**  
47 x 67 cm

**Pannello di controllo**

**Control panel**  
30 x h 6 cm

**Scatola da incasso pannello**

**Control panel mounting box**  
31 x 9,8 x h 6,6 cm

**Finishes**

Chrome.  
Brushed steel.

**Equipped shower head**

Ceiling shower head, rainfall, waterfall and mist function.

White Led lights.

Chromotherapy (Red, Blue, Green, Yellow) and "Feel" program.

3/4" built-in thermostatic mixer with 3-way diverter.

Touch-screen control panel with backlit icons operates all the functions (shower, steam, lighting).

Shower set with automatic on/off.

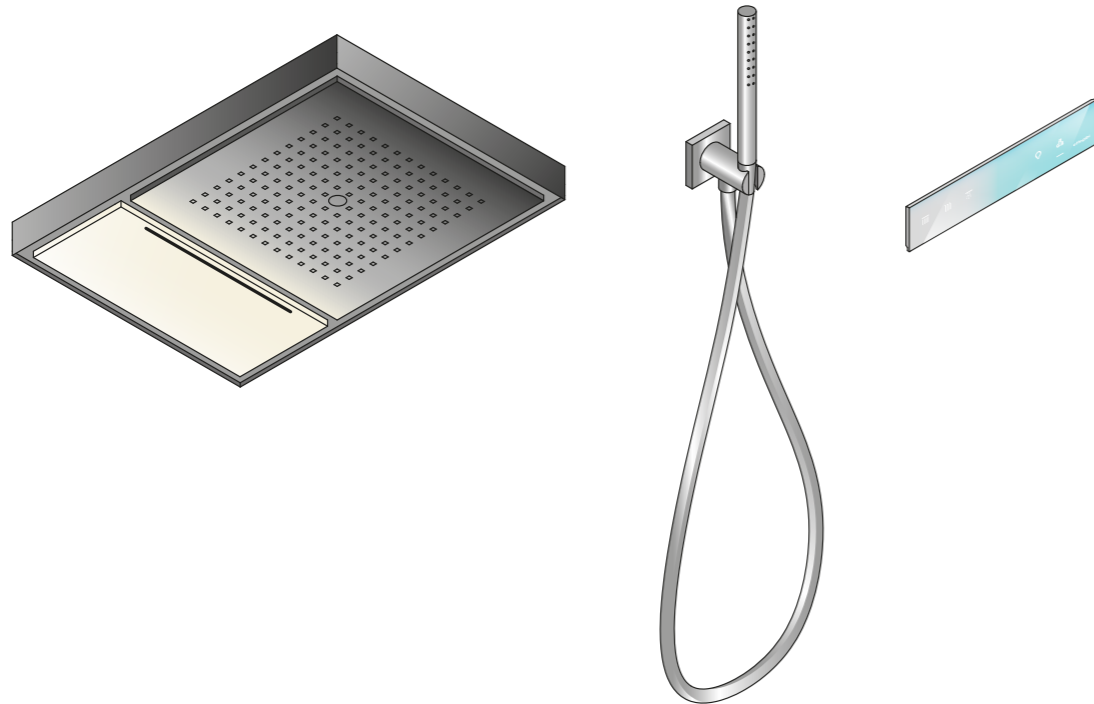

## FeelGood

Elegante collezione coordinata per il vostro spazio benessere: bagno turco, doccia multifunzionale e cromoterapia, tutto gestito dal pannello di controllo touch Effe ad alta tecnologia.

- › Sistema coordinato per spazio doccia con generatore di vapore e doccia multifunzione.
- › FeelGood può essere abbinato a qualsiasi generatore di vapore Effe.
- › Pannello di controllo touch con icone retroilluminate per la gestione di tutte le funzioni (doccia, vapore, luce).
- › Doccia con tre differenti getti d'acqua: acqua a pioggia, a cascata e nebulizzata.

An elegant coordinated collection for your personal spa: steam bath, multifunctional shower and colour therapy all operated by the high-tech Effe touch control panel.

- › A coordinated system for a shower space with steam generator and multifunctional shower.
- › FeelGood can be teamed with any Effe steam generator.
- › Touch-screen control panel with backlit icons operates all the functions (shower, steam, lighting).
- › Shower with three different flows of water: rain, waterfall and mist.







Touch-screen control panel with backlit icons operates all the functions.





Shower with three different flows of water:  
rain, waterfall and mist

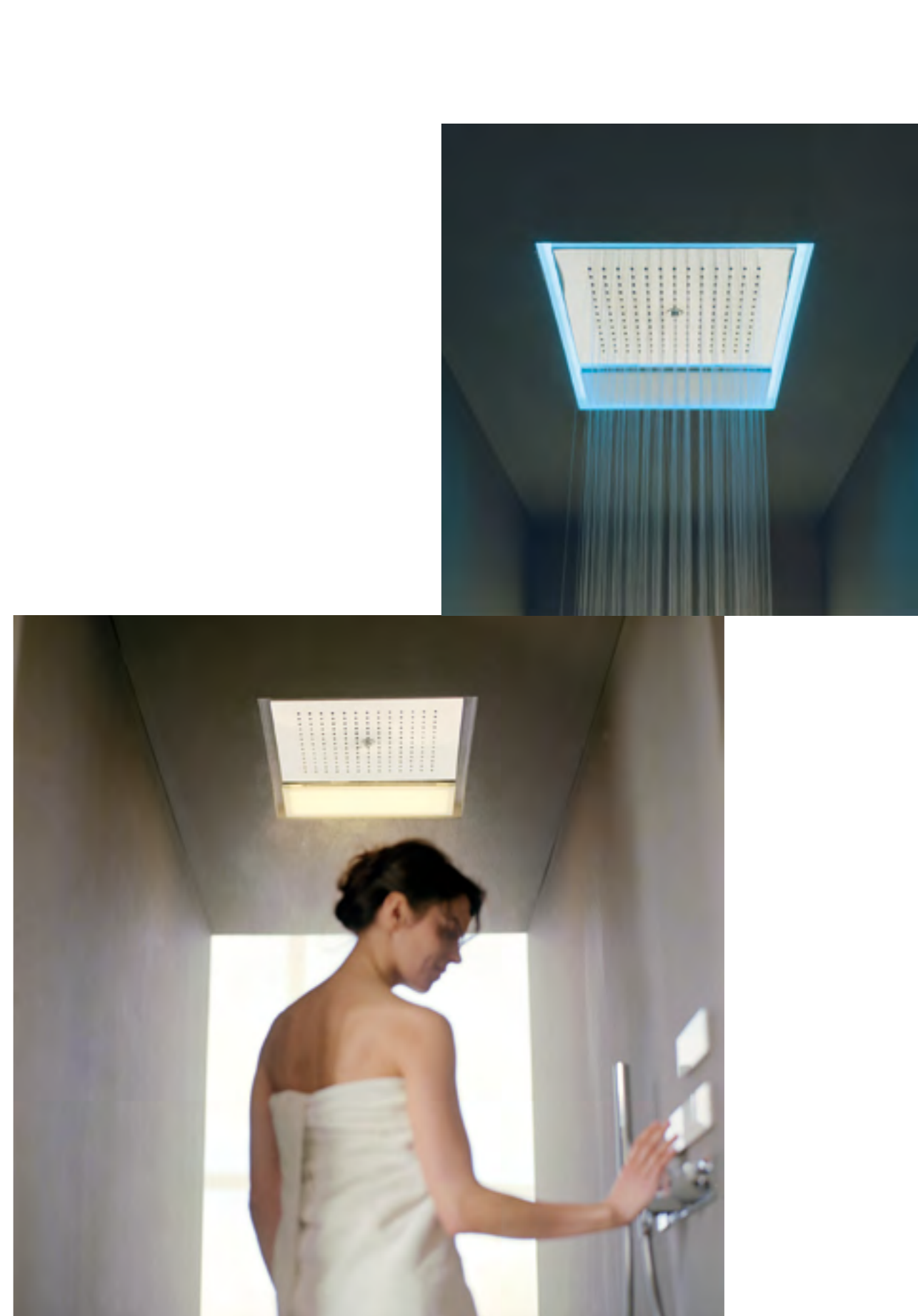



Coordinated FeelGood shower system teamed with Nuvola Smart Power. Touch-screen control panel with backlit icons operates all the functions (shower, steam, lighting).

## Translations

### FRANÇAIS

#### FeelGood

Élégante collection coordonnée pour votre espace de bien-être : bain turco, douche multifonctions et chromothérapie, le tout géré par le tableau de commande tactile Effe à haute technologie.

#### Caractéristiques :

Système coordonné pour espace douche avec générateur de vapeur et douche multifonctions.

FeelGood peut être combiné avec n'importe quel générateur de vapeur Effe.

Tableau de commande tactile avec icônes rétro-illuminées pour la gestion de toutes les fonctions (douche, vapeur, lumière).

Douche avec trois différents jets d'eau : eau à pluie, à cascade et nébulisée.

### ESPAÑOL

#### FeelGood

Elegante colección coordinada para vuestro espacio de bienestar: baño turco, ducha multifuncional y cromoterapia, todo gestionado desde el panel de control touch Effe de tecnología elevada.

#### Características:

Sistema coordinado para espacio ducha con generador de vapor y ducha multifunción.

FeelGood se puede combinar con cualquier generador de vapor Effe.

Panel de control touch con iconos retroiluminados para la gestión de todas las funciones (ducha, vapor y luz).

Ducha con tres distintos chorros de agua: agua en forma de lluvia, en cascada y nebulizada.

### 中文

#### FeelGood

为您的健康空间特别打造的优雅设计: 土耳其浴、多功能彩色光谱淋浴花洒, 均由Effe研发的高科技触控面板进行管理。

#### 特点:

专为蒸汽浴室打造的多功能淋浴花洒。FeelGood淋浴花洒可以和Effe品牌任何一款蒸汽发生器搭配使用。

触控式控制面板, 配置背光图标, 以控制所有功能的使用(淋浴、蒸汽、灯光)。

淋浴花洒有3种出水方式: 雨水效果, 瀑布效果以及迷雾效果。

### DEUTSCH

#### FeelGood

Elegante koordinierte Kollektion für Ihren Wellnessbereich: türkisches Dampfbad, Multifunktionsdusche und Farblichttherapie, angesteuert über das hoch technologische Touch-Bedienpaneel von Effe.

#### Beschreibung:

Koordiniertes System für den Duschbereich mit Dampfgenerator und Multifunktionsdusche.

FeelGood kann mit jedem Dampfgenerator von Effe kombiniert werden.

Touch-Bedienpaneel mit rückbeleuchteten Icons für die Ansteuerung von allen Funktionen (Dusche, Dampf, Licht).

Dusche mit drei verschiedenen Wasserstrahlformen: Regen, Wasserfall und Nebel.

### РУССКИЙ

#### FeelGood

Элегантная координированная коллекция для вашего персонального спа: турецкая баня, многофункциональный душ и хромотерапия. Все управление выведено на высокотехнологичную сенсорную панель Effe.

#### Характеристики:

Координированная система для душевого пространства с парогенератором и многофункциональным душем.

FeelGood можно сочетать с любым парогенератором Effe.

Сенсорная панель управления с символами с задней подсветкой для управления всеми функциями (душ, пар, освещение).

Душ с тремя различными режимами: дождь, водопад и туман.

**Fitbox A**

Anta in vetro e cerniere sul montante.

**Fitbox B**

Anta in vetro e cerniere sul vetro.

**Materiali**

Telaio in alluminio.  
Vetro temperato trasparente 8 mm.  
Tetto in vetro stratificato satinato 3+3 mm.

**Finiture**

Profili in alluminio finitura spazzolato.  
Profili in alluminio finitura anodizzato nero opaco.

**Caratteristiche**

Regolazione in larghezza e profondità  $\pm 0,5$  cm.  
Disponibile in versione destra o sinistra.  
Raggio di apertura porta 69 cm.  
Aerazione inferiore.  
Il FitBox è personalizzabile al centimetro.

**Fitbox A**

Glass door with hinges on the upright.

**Fitbox B**

Glass door with hinges on the upright.

**Materials**

Aluminium frame.  
Transparent 8mm toughened glass.  
Ceiling in satin-finish 3+3mm layered glass.

**Finish**

Brushed aluminium finish edges.  
Black edges in aluminium with a brushed black anodised finish.

**Features**

Width and depth adjustment  $\pm 0.5$ cm.  
Right or left-opening options.  
Door-opening radius 69 cm.  
Lower ventilation.  
FitBox can be personalised to the centimetre.

**Dimensioni**  
**Dimensions**

Fitbox A 120x80  
Fitbox B 120x80  
119 x 79 x h 220 cm

Fitbox A 140x90  
Fitbox B 140x90  
139 x 89 x h 220 cm

Su misura  
Custom size

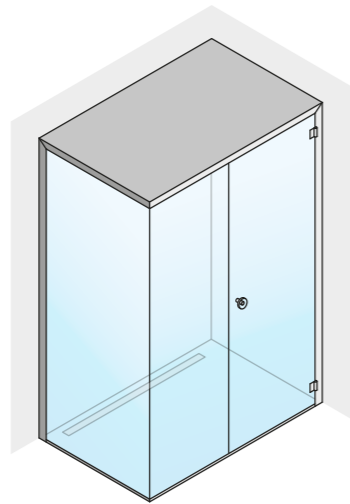

Fitbox A

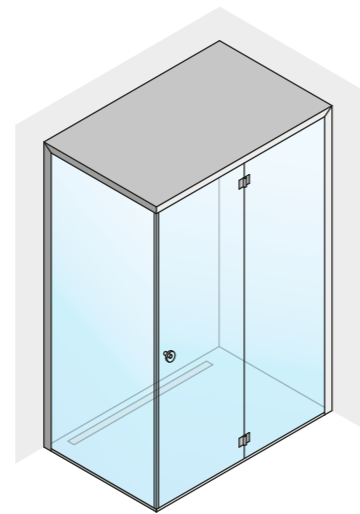

Fitbox B

## FitBox

Design: \_\_\_\_\_ **Giovanna Talocci,  
Marco Pallocca**

FitBox combina in un unico spazio la doccia con la funzione hammam. Il design sobrio e versatile consente un facile inserimento in ogni contesto di arredo.

FitBox è caratterizzato da prestazioni professionali e materiali di altissima qualità, elementi indispensabili per fare di acqua e vapore strumenti di benessere e piacere.

- › Profili in alluminio disponibili in due finiture: spazzolato e anodizzato nero opaco.
- › Personalizzazione delle dimensioni e delle configurazioni di apertura.
- › Applicazione anche direttamente a pavimento, eliminando qualsiasi barriera architettonica per l'ingresso in doccia.

FitBox combines a shower cubicle with Hammam in a single space. Its understated yet versatile design means it blends into any environment. Its professional features and top quality materials combine to make water and steam real vehicles of wellbeing and pleasure.

- › Aluminium frames available in two finishes: brushed and matte black anodised.
- › Infinite personalisation options as regards sizes and opening configurations.
- › Can be fitted directly on the floor, removing any architectural barriers when entering the shower.





Fitbox A with brushed aluminium finish.

## Translations

### FRANÇAIS

#### FitBox

FitBox combina en un único espacio la ducha con la función hammam. El diseño sobrio y versátil permite colocarlo fácilmente en cualquier espacio. FitBox se caracteriza por su rendimiento profesional y los materiales de calidad utilizados, elementos indispensables para convertir el agua y el vapor en instrumentos de bienestar y placer.

#### Caractéristiques :

Los perfiles de aluminio se encuentran disponibles en dos acabados, cepillado y anodizado negro mate. Es posible personalizar el tamaño y las configuraciones de apertura. Se puede aplicar también directamente en el suelo, eliminando cualquier barrera arquitectónica para la entrada en la ducha.

### DEUTSCH

#### FitBox

FitBox kombiniert in einem einzigen Raum die Dusche mit der Funktion Hamam. Dank des nüchternen und vielseitigen Designs lässt sich diese Kabine leicht in jede Raumgestaltung einfügen. FitBox bietet eine Profi-Performance und Materialien von höchster Qualität – unerlässliche Elemente, damit aus Wasser und Dampf angenehmes Wohlsein wird.

#### Beschreibung:

Die Aluminiumprofile sind in zwei Ausführungen erhältlich: gebürstet und anodisiert in Mattschwarz. Gestaltungsmöglichkeiten in puncto Abmessungen und Öffnung. Montage auch direkt am Boden, was jegliches architektonisches Hindernis für das Betreten der Dusche ausschließt.

### ESPAÑOL

#### FitBox

FitBox combina en un único espacio la ducha con la función hammam. El diseño sobrio y versátil permite colocarlo fácilmente en cualquier espacio. FitBox se caracteriza por su rendimiento profesional y los materiales de calidad utilizados, elementos indispensables para convertir el agua y el vapor en instrumentos de bienestar y placer.

#### Características:

Los perfiles de aluminio se encuentran disponibles en dos acabados, cepillado y anodizado negro mate. Es posible personalizar el tamaño y las configuraciones de apertura. Se puede aplicar también directamente en el suelo, eliminando cualquier barrera arquitectónica para la entrada en la ducha.

### РУССКИЙ

#### FitBox

FitBox – это душ и хаммам в едином пространстве. Благодаря лаконичности и универсальности дизайна изделие легко интегрируется в любой интерьер. FitBox сочетает в себе профессиональные эксплуатационные свойства и материалы высочайшего качества, позволяющие получить максимальное удовольствие и пользу от принятия душа и хаммама.

#### Характеристики:

Профили в двух вариантах: из шлифованного алюминия и из черного матового анодированного алюминия. Персонализация габаритов и направления открытия двери. Возможность установки изделия непосредственно на пол позволяет избежать лишних преград между кабиной и окружающим пространством.

### 中文

#### FitBox

FitBox在单个空间中整合了淋浴功能和土耳其桑拿浴室功能。优雅而多功能的设计令其可以完美搭配不同的室内装饰风格。FitBox系列有着出色的专业级性能和高品质的原材料，可以利用水和蒸汽这些基本元素为您带来身心健康和舒适享受。

#### 特点:

铝合金框架有两种装饰效果：磨砂处理或哑光黑色阳极氧化处理。尺寸与门框位置均可个性化定制。可以采用直接的落地设计，避免在进入淋浴房时出现任何结构性障碍物。

#### Materiali

Vasca in materiale composito.

Portello vano comandi disponibile in:

- Composito in finitura vasca nella versione standard;
- Grès porcellanato su supporto in acrilico retro illuminato.

#### Caratteristiche/Componenti

- Portello apribile.
- Pareti isolate termicamente.
- Funzione Source.
- Funzione ricircolo e filtrazione.
- Sistema filtrante con skimmer a doppia cartuccia.
- Riscaldatore elettrico.
- Ozonizzatore.
- Blade light a Led RGB.
- Pannello elettronico di comando.

#### Optional

- Funzione Whirlpool: idromassaggio rapido con 8 jet.
- Funzione Air Milk: ossigenazione dell'acqua con flusso leggero, che rende il liquido di colore bianco opaco e morbido al tatto.
- Funzione Blower: idromassaggio forte a 16 jet con riscaldamento del flusso.
- ESS - Effe Sound System.
- Portello retroilluminato.
- Telaio acciaio zincato con piedini regolabili.

#### Dimensioni

##### Dimensions

208 x 208 x h 80,5 cm

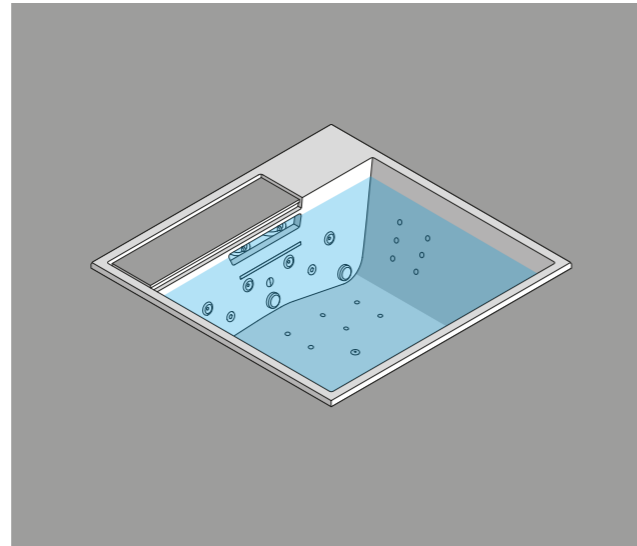

#### Materials

Bath in composite material.

Control space door available in:

- Standard version with composite material, according to bath finish;
- Options version in grès porcelain on a back-lit acrylic support.

#### Features/Components

- Door that can be opened.
- Walls with heat insulation.
- Source Function.
- Recirculation and filtration function.
- Filter system with double cartridge skimmer.
- Electric heater.
- Ozonator.
- RGB Led blade light.
- Electronic control panel.

#### Optional

- Whirlpool function: rapid whirlpool with 8 jets.
- Air Milk function: the gently flowing water is oxygenated, making it milky white and soft to the touch.
- Blower function: strong whirlpool with 16 jets and heated flow.
- ESS - Effe Sound System.
- Black-lit door.
- Galvanised steel frame with adjustable feet.

WaterDream  
/ mini pool /

## WaterDream

Design: \_\_\_\_\_ Giovanna Talocci,  
Marco Pallocca

La mini piscina è uno spazio di relax totale dedicato al rapporto tra acqua e corpo. Varie modalità di idromassaggio uniti a movimenti di luce colorata creano piacevoli atmosfere dedicate al benessere.

- › La mini piscina consente di mantenere l'acqua al suo interno per lunghi periodi di tempo, senza svuotarla ad ogni utilizzo.
- › Funzione Source: leggero flusso dell'acqua che parte dal fondo della vasca e genera un movimento circolare.
- › WaterDream è facilmente integrabile in qualsiasi contesto di arredo bagno grazie alla personalizzazione del pannello che nasconde il quadro comandi, posto al lato della vasca.

The mini pool is a space for total relaxation, for celebrating the water-body relationship. Its different whirlpool modes, combined with the moving coloured lights, create a pleasant atmosphere conducive to wellbeing.

- › Water can be kept in the mini pool for long periods of time, without having to empty it every time.
- › Source function: gentle water flow from the bottom of the bath which generates circular movement.
- › WaterDream can be installed in any bathroom, thanks to the customisable panel on the side of the bath which conceals the controls underneath.







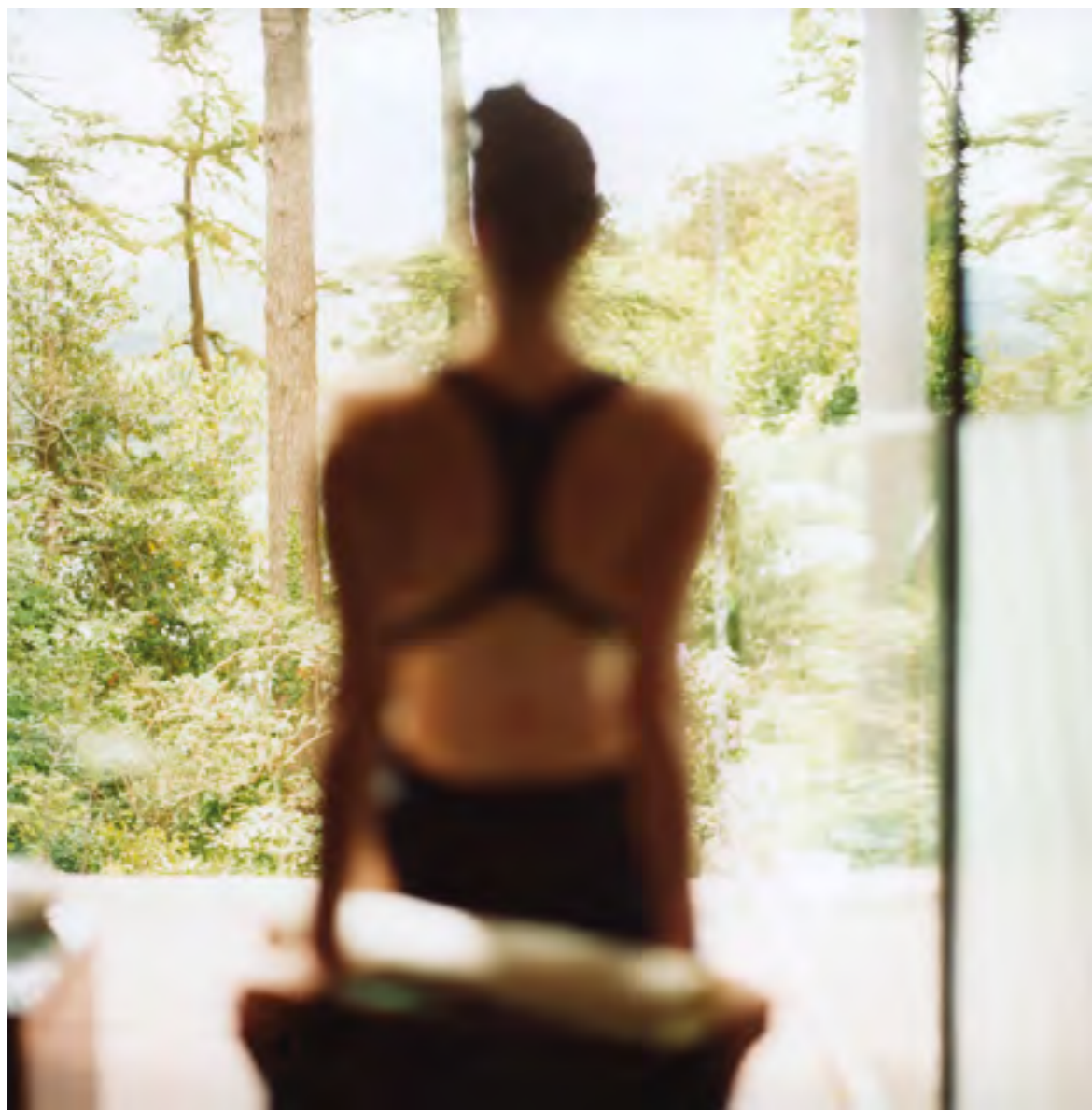

## Translations

### FRANÇAIS

#### WaterDream

La mini piscine est un espace de détente totale dédié au rapport entre eau et corps. Différents modes d'hydromassage combinés à des mouvements de lumière colorée créent des atmosphères agréables dédiées au bien-être.

#### Caractéristiques :

La mini piscine permet de garder l'eau à l'intérieur pendant de longues périodes, sans la vider après chaque utilisation.  
 Fonction Source : léger flux d'eau qui part du fond de la baignoire et génère un mouvement circulaire.  
 WaterDream peut être facilement intégrée dans n'importe quel contexte d'ameublement de la salle de bain grâce à la personnalisation du panneau qui cache le tableau de commandes, placé sur le côté de la baignoire.

### DEUTSCH

#### WaterDream

Der Minipool, ein Raum für absolute Entspannung – im Mittelpunkt steht die Beziehung zwischen Wasser und dem Körper. Mehrere Whirlpool-Funktionen vereint mit farbigen Lichtspielen schenken ganz besondere Wohlfühlatmosphären.

#### Beschreibung:

Der Minipool kann für lange Zeit mit Wasser gefüllt sein und muss nicht nach jeder Benutzung geleert werden.  
 Funktion Source: Ein sanfter Wasserstrom am Wannenboden erzeugt eine kreisförmige Bewegung.  
 Dank der individuellen Gestaltung der Blende an der Wannenseite, welche die Bedienelemente verdeckt, lässt sich WaterDream leicht in jeden Badezimmer-Kontext einfügen.

### ESPAÑOL

#### WaterDream

La minipiscina es un espacio de relax total dedicado a la relación entre agua y cuerpo. Diversas modalidades de hidromasaje y movimientos de luces de colores crean atmósferas agradables dedicadas al bienestar.

#### Características:

La minipiscina permite mantener el agua en su interior durante periodos de tiempo largos, sin vaciarla cada vez que se utiliza.  
 Función Source: flujo de agua ligero desde el fondo de la bañera que genera un movimiento circular.  
 WaterDream se integra fácilmente en cualquier contexto de mobiliario de baño gracias a la personalización del panel que esconde el tablero de control situado al lado de la bañera.

### РУССКИЙ

#### WaterDream

Мини-бассейн – это идеальное место для полной релаксации в абсолютной гармонии с водой. Различные виды гидромассажа в сочетании с динамической цветной подсветкой создают идеальную атмосферу для полноценного мультисенсорного отдыха.

#### Характеристики:

Мини-бассейн позволяет хранить воду в течение длительных периодов времени без необходимости осушения купели после каждого использования.  
 Функция Source: легкий восходящий поток воды со дна ванны, создающий круговое движение.  
 WaterDream легко интегрируется в любой интерьер благодаря возможности персонализации боковой панели, скрывающей панель управления.

### 中文

#### WaterDream

迷你泳池是一个让人彻底放松的空间，旨在庆祝水人合一的关系。多种旋流按摩模式，加上不断变换彩色灯光，营造出令人愉悦的氛围，有助身心健康。

#### 特点:

水可以长期保存在迷你泳池中，无需每次清空。  
 Source 功能: 轻柔的水流会从浴缸底部喷出，在浴缸内循环流动。  
 WaterSuite 采用位于浴缸侧面的定制面板，并将控制按钮隐藏在面板下方，因此可以安装到任何浴室中。

#### Materiali

Vasca in PMMA acrilico colato spessore 5 mm.  
Portello vano comandi disponibile in:  
Composito in finitura vasca nella versione standard.  
Grès porcellanato su supporto in acrilico retro illuminato.

#### Caratteristiche/Componenti

Portello apribile.  
Rubinetteria alta portata.  
Erogazione con cascata.  
Doccetta a mano con flessibile.  
Colonna di scarico.  
Funzione Source.  
Pannello elettronico di comando.  
Blade Light a Led RGB.  
Sistema di sanificazione manuale.

#### Optional

Funzione Whirlpool: idromassaggio rapido con 8 jet.  
Funzione Air Milk: ossigenazione dell'acqua con flusso leggero, che rende il liquido di colore bianco opaco e morbido al tatto.  
Funzione Blower: idromassaggio forte a 8 jet con riscaldamento del flusso.  
ESS - Effe Sound System.  
Portello retroilluminato.  
Telaio acciaio zincato con piedini regolabili.

#### Dimensioni

Dimensions  
160 x 180 x h 63,5 cm

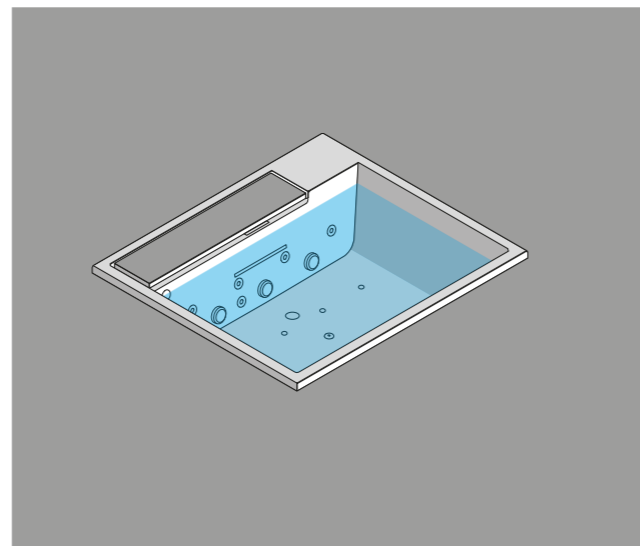

#### Materials

Bath in cast acrylic PMMA, thickness 5 mm.  
Control space door available in:  
Standard version with composite material, according to bath finish.  
Options version in grès porcelain on a back-lit acrylic support.

#### Features/Components

Door that can be opened.  
High flow taps.  
Waterfall delivery.  
Hand-held shower head with flexible tube.  
Outlet.  
Source Function.  
Electronic control panel.  
RGB Led blade light.  
Manual sanitation system.

#### Optional

Whirlpool function: rapid whirlpool with 8 jets.  
Air Milk function: the gently flowing water is oxygenated, making it milky white and soft to the touch.  
Blower function: strong whirlpool with 8 jets and heated flow.  
ESS - Effe Sound System.  
Black-lit door.  
Galvanised steel frame with adjustable feet.

## WaterSuite

Design: \_\_\_\_\_ Giovanna Talocci,  
Marco Pallocca

Con WaterSuite, l'acqua ritorna ad assumere un ruolo centrale nel benessere di tutti i giorni. La funzione di serie Source genera un movimento leggero dal fondo della vasca che rilassa profondamente il corpo e stimola la circolazione. Giochi di luce sommersa completano questo prodotto elegante e versatile.

> Vasca dotata di varie tipologie di idromassaggio e funzione di cromoterapia Blade Light a Led RGB.

> WaterSuite è facilmente integrabile in qualsiasi contesto di arredo bagno grazie alla personalizzazione del pannello che nasconde il quadro comandi, posto al lato della vasca.

Thanks to WaterSuite, water becomes a key part of our everyday wellbeing once more. The Source function, one of its standard features, generates gentle movement from the bottom of the bath, lulling the body into a deeply relaxed state and stimulating circulation. Underwater light effects add the finishing touch to this elegant and versatile product.

> Bath fitted with whirlpool modes and Blade Light colour therapy with RGB Led lighting.

> WaterSuite can be installed in any bathroom, thanks to the customisable panel on the side of the bath which conceals the controls underneath.





## Translations

### FRANÇAIS

#### WaterSuite

Avec WaterSuite, l'eau assume à nouveau un rôle central dans le bien-être quotidien. La fonction de série Source génère un léger mouvement depuis le fond de la baignoire qui détend profondément le corps et stimule la circulation. Des jeux de lumière submergée complètent ce produit élégant et polyvalent.

#### Caractéristiques :

Baignoire dotée de différents types d'hydromassage et de la fonction chromothérapie Blade Light à LED RGB. WaterSuite peut être facilement intégrée dans n'importe quel contexte d'ameublement de la salle de bain grâce à la personnalisation du panneau qui cache le tableau de commandes, placé sur le côté de la baignoire.

### DEUTSCH

#### WaterSuite

Mit WaterSuite wird Wasser wieder zum zentralen Element unseres alltäglichen Wohlbefindens. Die serienmäßige Funktion Source erzeugt eine leichte Bewegung am Wannenboden, die den Körper in einen tiefen Entspannungszustand versetzt und den Kreislauf anregt. Lichtspiele unter Wasser vervollständigen dieses elegante und vielseitige Produkt.

#### Beschreibung:

Whirlpool mit mehreren Funktionen und der Farblichttherapie LED-RGB-Bladelight. Dank der individuellen Gestaltung der Blende an der Wannenseite, welche die Bedienelemente verdeckt, lässt sich WaterSuite leicht in jeden Badezimmer-Kontext einfügen.

### ESPAÑOL

#### WaterSuite

Con WaterSuite el agua asume de nuevo un papel central en el bienestar de todos los días. La función de serie Source genera un movimiento ligero desde el fondo de la bañera que relaja profundamente el cuerpo y estimula la circulación. Juegos de luces enterradas completan este producto elegante y versátil.

#### Características:

Bañera equipada con diversos tipos de hidromasaje y función de cromoterapia Blade Light con Led RGB. WaterSuite se integra fácilmente en cualquier contexto de mobiliario de baño gracias a la personalización del panel que esconde el tablero de control situado al lado de la bañera.

### РУССКИЙ

#### WaterSuite

Благодаря бассейну WaterSuite вода снова становится центром Вашего ежедневного спа-ритуала. Входящая в стандартную комплектацию функция Source создает легкое восходящее движение воды со дна ванны, улучшая кровообращение и обеспечивая ощущение глубокого расслабления. Подводные световые эффекты дополняют это элегантное и универсальное изделие.

#### Характеристики:

Ванна оснащена различными видами гидромассажа и светодиодной подсветкой Blade light с функцией хромотерапии RGB. WaterSuite легко интегрируется в любой интерьер благодаря возможности персонализации боковой панели, скрывающей панель управления.

### 中文

#### WaterSuite

得益于 WaterSuite, 水成为我们确保日常身心健康不可或缺的部分。标配 Source 功能, 可从浴室底部喷出柔和的水流, 帮助身体进入深层放松状态并刺激血液循环。水下灯光效果提升这款优雅的多功能产品的装饰效果。

#### 特点:

浴缸具备旋流按摩模式, 以及采用 RGB LED 照明的 Blade Light 色彩疗法。WaterSuite 采用位于浴缸侧面的定制面板, 并将控制按钮隐藏在面板下方, 因此可以安装到任何浴室中。



È possibile ascoltare la propria musica preferita all'interno della sauna o dell'hammam utilizzando la connessione Bluetooth del proprio Tablet o Smartphone. Dotata di due casse stereo, Effe Sound System si collega automaticamente agli altoparlanti interni senza dover installare software o predisporre collegamenti specifici.

You can listen to your favourite music inside the sauna or hammam using a Bluetooth connection and your own device. The Effe Sound System, which has two stereo speakers, connects automatically to the internal speaker with no need to install any software or make special connections.

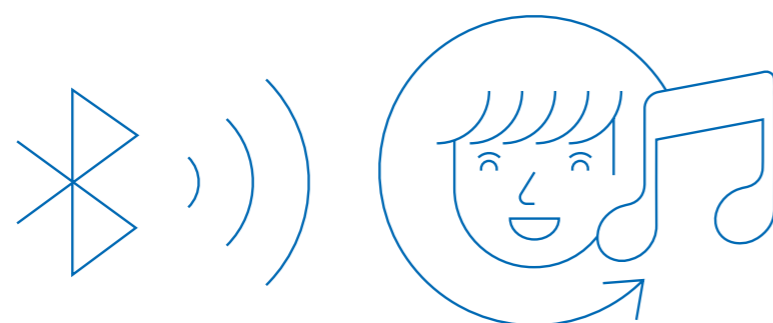

**ESS**  
**EFFE SOUND**  
**SYSTEM**

Sistema che consente di gestire a distanza il bagno turco o la sauna, scaricando l'apposita App Effegibi Experience (disponibile su ambiente iOS) sul proprio Tablet o Smartphone. È possibile personalizzare la propria esperienza comodamente da altri ambienti della casa ed eseguire funzioni quali impostazione dell'ora di accensione, della temperatura e selezione della luce preferita. La copertura Wi-Fi nell'ambiente in cui sono inseriti il bagno turco o la sauna permette una programmazione remota da qualsiasi luogo (ufficio, auto, ecc.). Infine l'App Effegibi Experience permette di avere informazioni utili sull'utilizzo del prodotto: da come utilizzarli al meglio a quali sono i suoi benefici.

This system can control remotely the sauna or the steam bath. To enable it, just download the Effegibi Experience App (available on iOS) to your Tablet or Smartphone. This makes it possible to personalise your own experience conveniently from other places in your home and pre-set such functions as switch-on time, temperature and your preferred light selection. The Wi-Fi cover in the sauna or hammam area enables you to program it remotely from almost any other location, such as your office or car. Last but not least, the Effegibi Experience App provides you with useful information about the product, such as how to get the best out of your sauna or your hammam and its health benefits.



Available on the  
**App Store**

**ECC**  
**EFFE COMFORT**  
**CONTROL**

# PORTE E VETRATE

# DOORS AND GLASS PANELS

Le speciali porte Effe per hammam sono progettate per ottenere una tenuta perfetta alla fuoriuscita del vapore, garantendo il giusto ricircolo d'aria. L'acciaio inox, l'alluminio e il vetro temperato di 8 mm di spessore rendono ogni modello molto durevole e facilmente abbinabile allo stile di ogni arredamento. Grazie alle porte Effe, anche la semplice doccia di casa può essere trasformata in un perfetto bagno turco.

The special doors created by Effe for Hammams are designed to ensure a perfect seal against the escape of steam thus ensuring proper air circulation. Stainless steel and 8mm-thick toughened glass make each model tough and long-lasting and easily adaptable to any furnishing style. Effe's special doors also enable any ordinary home shower to be transformed into the perfect steam bath.

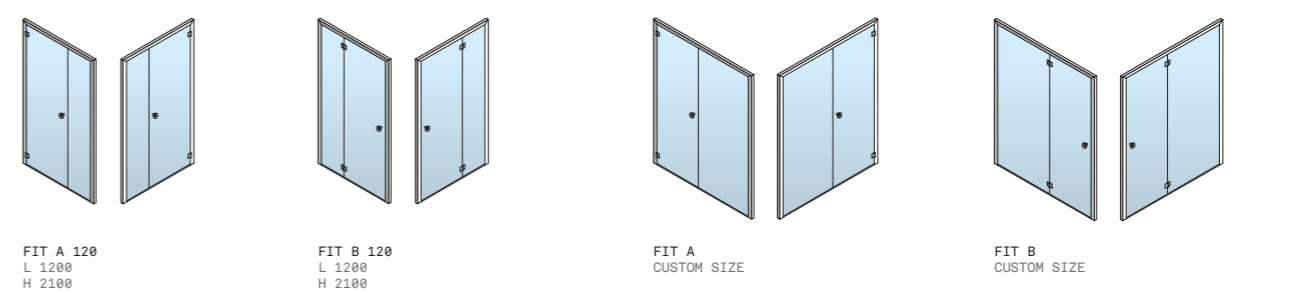
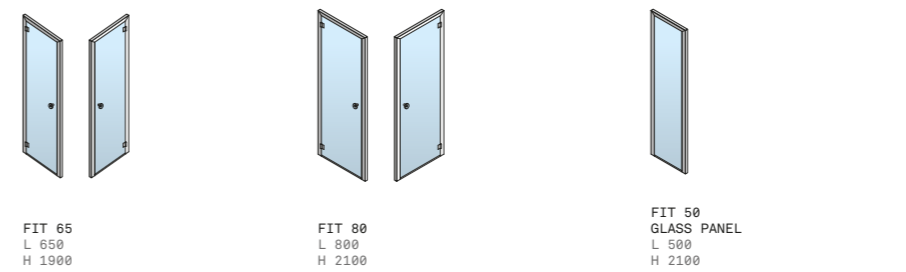
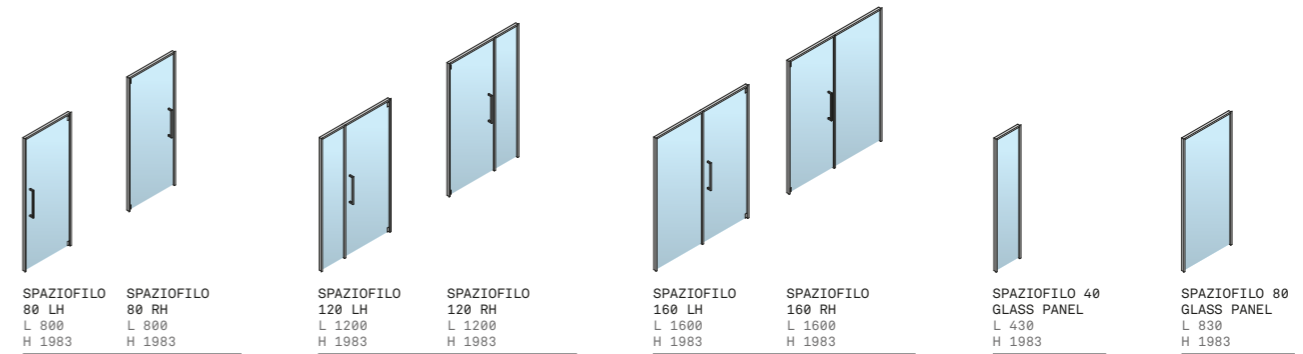
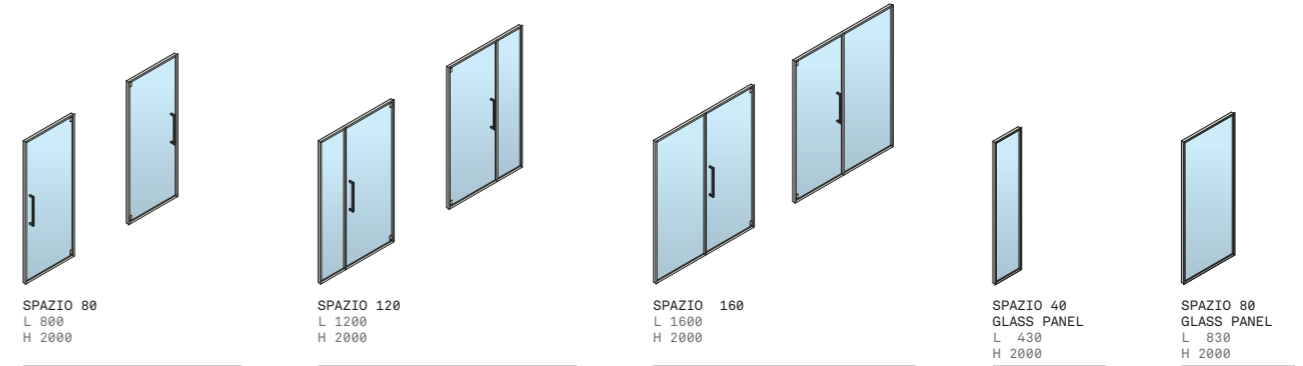
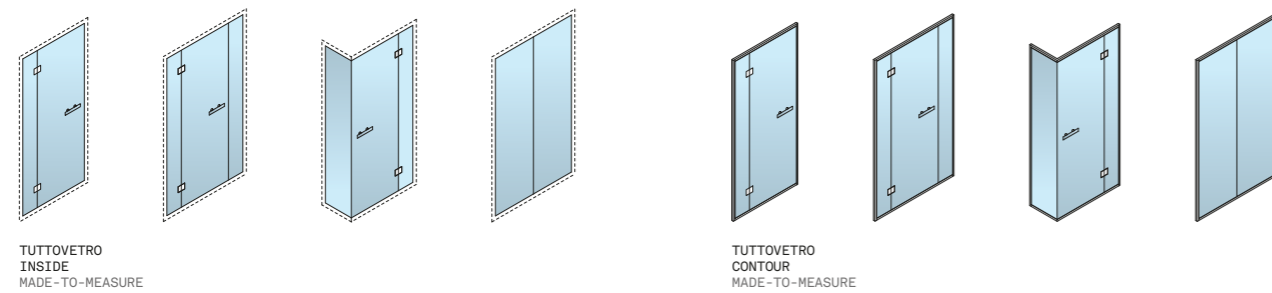
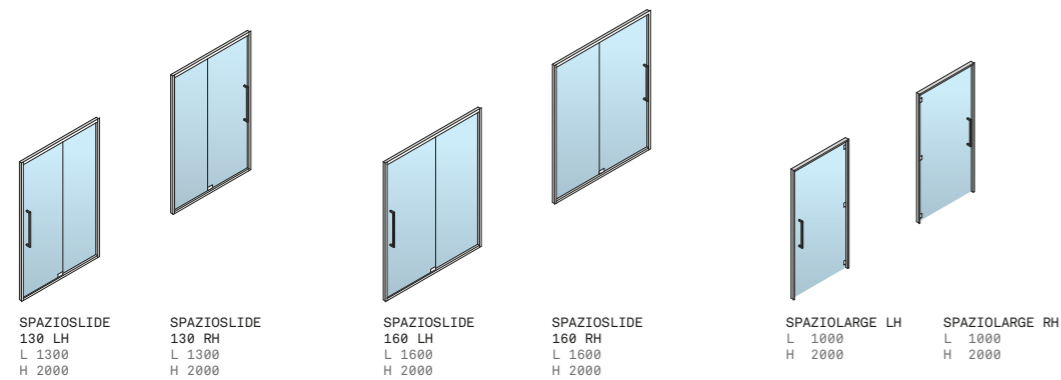





Tuttovetro Inside  
doors and glass panels



## TUTTOVETRO

**Caratteristiche**  
Porta con apertura classica.  
A filo pavimento.  
Installata su controtelaio.  
Profili in acciaio.

**Features**  
Classic pull-open door.  
Flush with the flooring.  
Fitted to the counterframe.  
Steel edges.

< 1  
Tuttovetro Inside



< 2  
Tuttovetro Contour



## SPAZIO

**Caratteristiche**  
Reversibile.  
Installata su controtelaio.  
Profili in acciaio.

**Features**  
Reversible.  
Fitted to the counterframe.  
Steel edges.



## SPAZIOFILO

**Caratteristiche**  
Porta con apertura classica.  
A filo pavimento.  
Installata su controtelaio.  
Profili in acciaio.

**Features**  
Classic pull-open door.  
Flush with the flooring.  
Steel edges.



## SPAZIOSLIDE

**Caratteristiche**  
Apertura scorrevole.  
Disponibile in versione  
destra o sinistra.  
Installata su controtelaio.  
Profili in acciaio.

**Features**  
Sliding version.  
Right or left-opening  
options.  
Fitted to the counterframe.  
Steel edges.



## FIT

**Caratteristiche**  
Porta con apertura classica.  
Disponibile in versione destra  
o sinistra.  
Profili in alluminio spazzolato.

**Features**  
Classic pull-open door.  
Right or left-opening options.  
Brushed aluminium frames.

## SEDUTE E FONTI

## SEATING AND SPRINGS

Serie di arredi progettati in maniera specifica per l'interno dell'hammam e della doccia, con materiali facili da pulire e resistenti all'azione dell'acqua.

A range of fittings specially designed for the inside of the Hammam and shower, made of easy-to-clean and water-resistant materials.

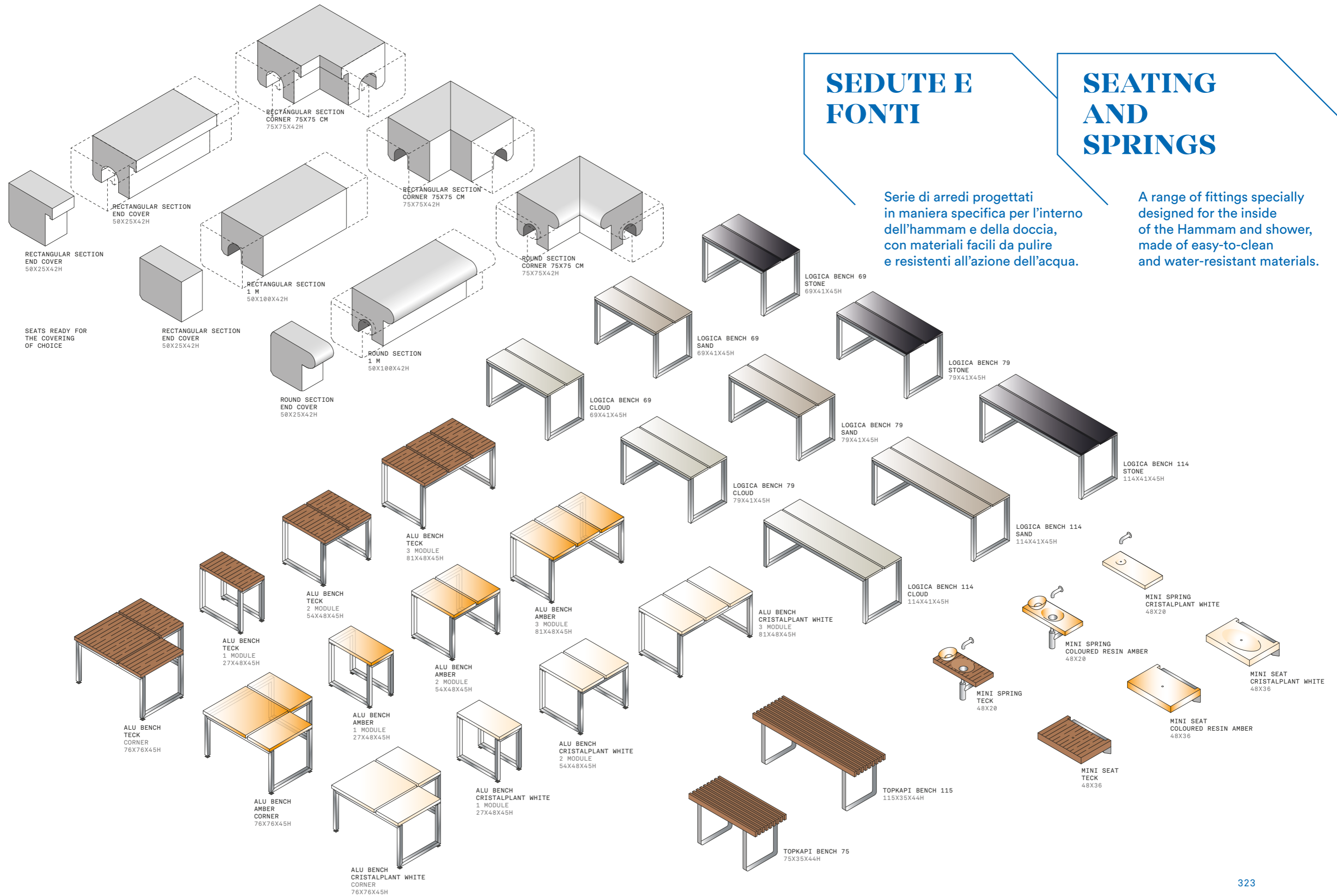



1 >



2 >



Mini Seat and Mini Spring  
Model: coloured resin amber



Mini Seat  
Model: coloured resin amber

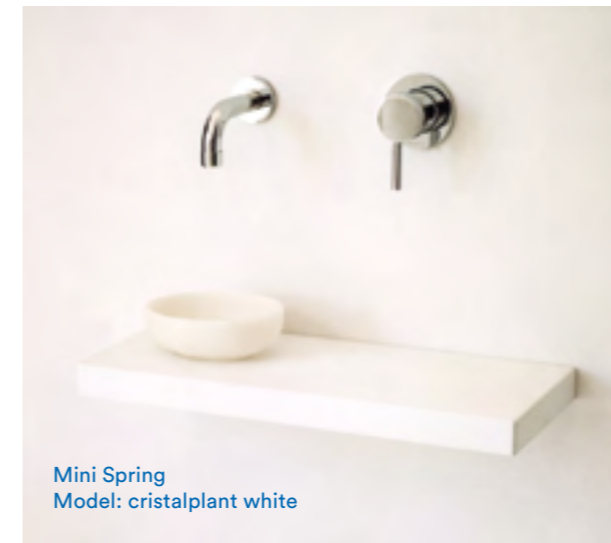

Mini Spring  
Model: cristalplant white

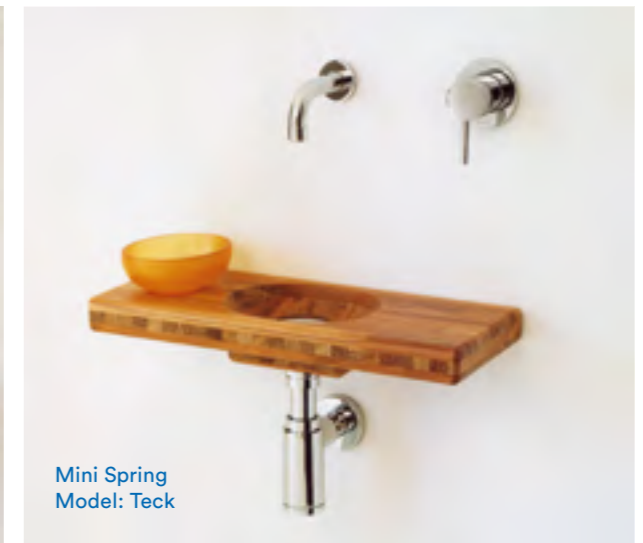

Mini Spring  
Model: Teck



Linea Alu Bench  
Model: corner - Teck



Linea Alu Bench  
Model: 3 module - cristalplant white

## ARREDI E ACCESSORI

## FURNISHINGS AND ACCESSORIES

Effe ha studiato complementi d'arredo come poltrone, lettini, tavoli e chaise longue, che si abbinano a saune e hammam per completare con stile la vostra area benessere.

Effe has designed a complete range of fittings for saunas and Hammams with armchairs, loungers, tables and chaise longues to complete your spa area in style.

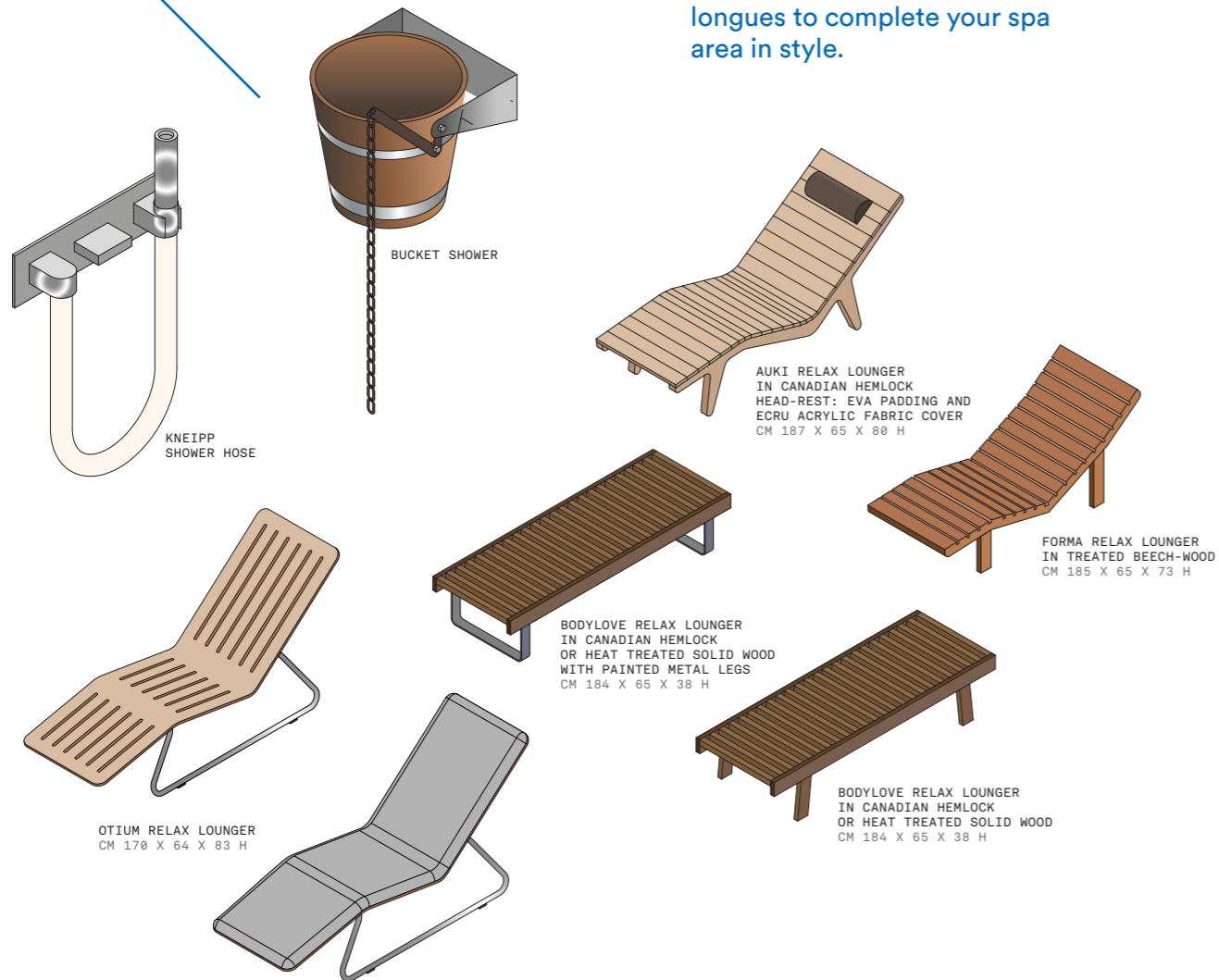

1 >



2 >



1 >



2 >

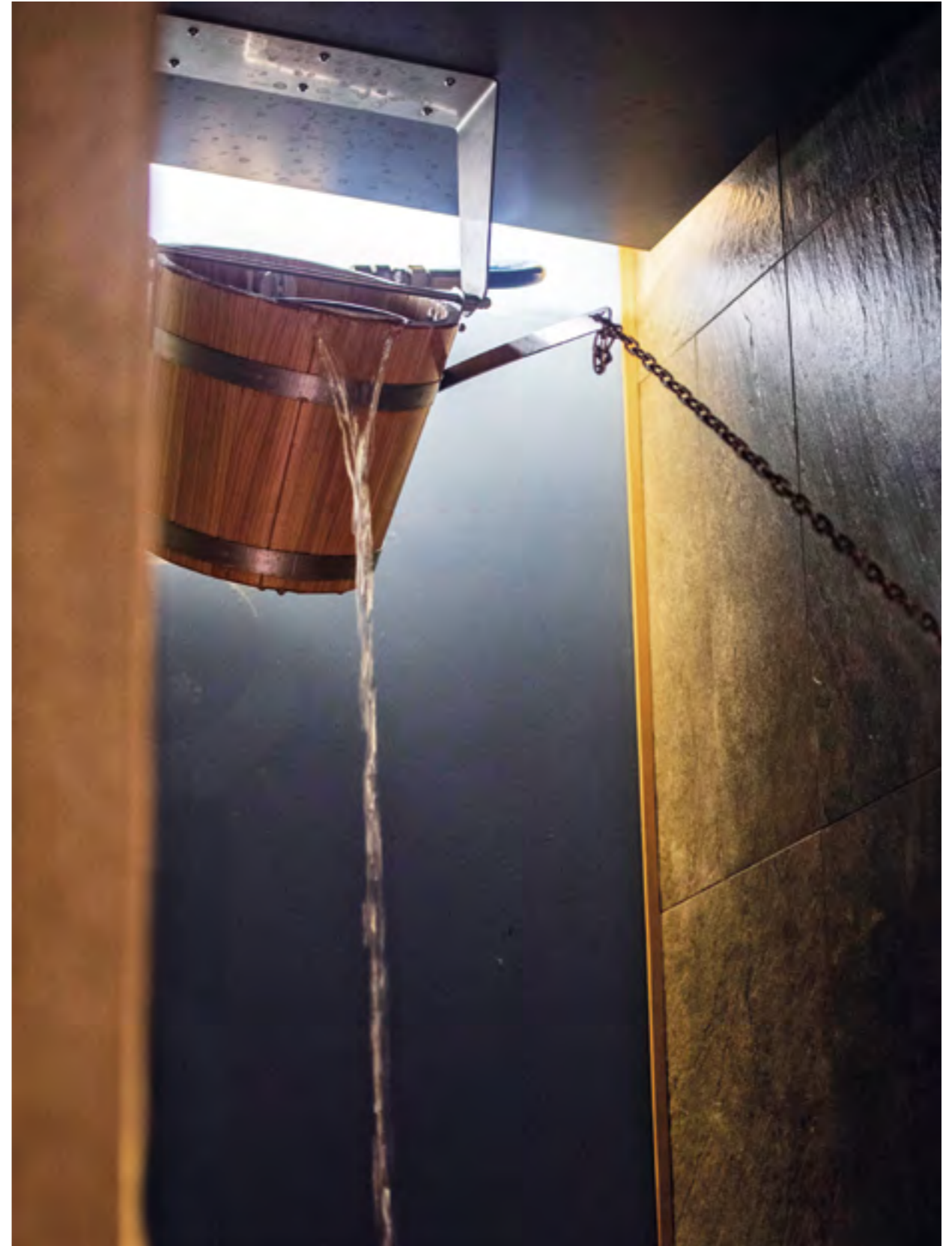

Effe presenta in collaborazione con Remedia, azienda che utilizza prodotti naturali e biologici coltivati e lavorati secondo antiche tradizioni di erboristeria alchemica, una linea di fragranze per sauna e hammam che ampliano i benefici di questi antichi rituali con una dimensione olfattiva e onirica.

Effe has come together with Remedia, which uses natural organic products that are grown and processed according to ancient traditions of alchemical herbalism, to create a range of fragrances for saunas and Hammams which heighten the benefits of these ancient rituals thanks to their olfactory and almost dreamlike effect.

**PERFECT  
WELLNESS  
FRAGRANCES**

## Acqua.

**Fluidità,  
Equilibrio,  
Armonia.**

Nella gioia si esprime il sorriso di Arancio dolce che culla il piacere di vivere. Le note profumate ritmano il canto dell'acqua, semplice e puro come Lavanda, pulito e cristallino come Eucalipto.

Acqua ci coccola, si prende cura di noi, ci avvicina alle emozioni più incantate, lascia spazio al bambino interiore. Ci accompagna a trovare serenità ed armonia. Il rituale diventa un momento di pace profonda.



## Water.

**Fluidity,  
Balance,  
Harmony.**

Joy brings the smile of sweet orange which nurtures life's pleasures. The scented notes bring rhythm to the sound of water, simple and pure like lavender, crisp and clear like eucalyptus.

Water pampers us, it takes care of us, it puts us in touch with magical feelings, it brings out the child in us. It helps us find peace and harmony. The ritual becomes a moment of profound peace.

## Fuoco.

**Passione,  
Forza vitale,  
Sistema  
immunitario.**

Note agrumate danno spazio e ardore al caldo Cardamomo attorno al quale danza l'intrepido Ginepro dalle note suadenti e fortificanti. Nulla può resistere all'ingresso di Cannella dolce, calda e curativa come il sole.

Fuoco è energia, pura vita celebrata nell'ardore e nella forza. Tutto il corpo si riallinea e si appassiona. Il rituale ci ricarica e stimola la nostra forza vitale agendo sul sistema immunitario.



## Fire.

**Passion,  
Life force,  
Immune  
system.**

Citrus notes give space and passion to warm cardamom, accompanied by fearless juniper with its mellow, fortifying notes. Sweet cinnamon is irresistible, warming and healing us like the sun.

Fire is energy, pure life celebrated with passion and strength. The whole body is realigned and energised. The ritual gives us renewed energy and stimulates our life force, with benefits for the immune system.

## Terra.

**Radicamento,  
Corpo fisico,  
Centratura,  
Presenza.**

Note intense e profonde di Vetiver e Cedro avvolgono il corpo e celebrano la sua sacralità. Il suadente Patchouli acquieta la mente e dona sensualità accompagnato alla dolcezza da Benzoino e Coriandolo.

Terra ci accompagna alla sacralità del Corpo e esalta il rituale della Sauna o del Bagno Turco quando ci siamo dimenticati della nostra presenza fisica. Aiuta a riconnetterci con le esigenze del corpo e dei suoi veritieri messaggi.



## Earth.

**Roots,  
Physical body,  
Centring,  
Presence.**

Intense, profound notes of vetiver and citron envelop the body and celebrate its sacred being. Persuasive patchouli calms the mind and conveys sensuality, with benzoin and coriander adding to the sweetness.

Earth accompanies us as we explore the sacred nature of the body and enhances the ritual of the sauna or steam bath when we have forgotten our physical presence. It helps reconnect us with the needs of our body and its true messages.

## Aria.

**Pensiero,  
Spaziosità,  
Respiro,  
Leggerezza.**

Il suono di Litsea arriva da lontano e si annuncia fresco e rigenerante come il vento che spazza nubi nere. Il balsamico Alloro ne amplia il respiro e riconduce la mente alla purezza sul tintinnio della Menta.

Aria purifica la mente sovraccarica, la libera, la alleggerisce. Dilegua il peso del mentale e sostiene il respiro. Il rituale ci rigenera e ci apre a nuovi vedute.



## Air.

**Thought,  
Spaciousness,  
Breath,  
Lightness.**

The scent of litsea comes from afar, fresh and regenerating like the wind that chases away dark storm clouds. The balsamic effect of bay accentuates these notes and restores purity to the mind, accompanied by refreshing mint.

Air purifies our troubled mind, frees it, unburdens it. It lightens the weight of our thoughts and supports out breath. The ritual regenerates us and opens our mind to new horizons.

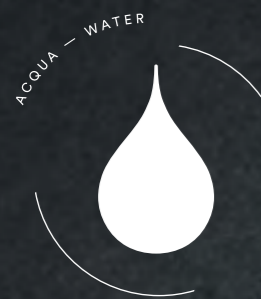



Effe è al centro di una storia che parte dalla tradizione e arriva nel futuro più innovativo. La storia è quella del benessere, di antichi riti come la sauna e il bagno turco che oggi assumono una veste contemporanea grazie a tecnologie avanzate e raffinato design. Dietro a questa evoluzione c'è un'azienda che dal 1987 ha dedicato la sua attività unicamente a questo settore, orgogliosa di offrire una produzione di bagni turchi e saune interamente italiana, dalla progettazione alla produzione.

Con questa filosofia Effe è divenuta meritatamente leader nel suo campo, conquistando la fiducia di clienti in tutto il mondo. Un punto di forza è dato dall'eccellenza delle soluzioni tecnologiche, sempre all'avanguardia che garantiscono prodotti di qualità certificata, di lunga durata, con manutenzione ridottissima e risparmio energetico.

Oltre a ricercare elevate prestazioni e funzionalità, Effe sa bene che l'armonia dello spazio influenza il nostro benessere fisico e quindi pone uguale attenzione anche all'estetica. Saune e bagni turchi sono disegnati con linee pulite, tracciate da illustri designer, spesso con grandi aperture vetrate che le trasformano in eleganti oggetti di arredamento.

I materiali sono ecocompatibili, non viene utilizzata plastica, i tipi di legno sono di prima scelta e non provengono da deforestazione o da alberi in estinzione. Lo straordinario know-how di Effe si traduce in accurate soluzioni su misura.

Effe is central to a story that starts with tradition and stretches right into the most innovative future. This is a story of wellbeing, of the ancient traditions of the sauna and the steam bath that today's advanced technology and design excellence have clothed in a new guise. This evolution has been made possible by our company that, since 1987, has focused entirely on this sector and we are proud to offer saunas and steam baths that are 100% Italian, from design to manufacture.

This philosophy has enabled Effe to become the well-deserved leader in our field, winning the trust of our customers the world over. One of our strong points is the excellence of our high-tech solutions, always in the vanguard of progress with long-lasting, energy-saving products of certified quality, requiring very little maintenance.

In addition to our constant quest for high performance and practicality, we at Effe are fully aware that feeling good equates to looking good and so we take just as much care over aesthetics. Our saunas and steam baths feature clean lines traced by such famous designers, often with generous expanses of glass that transform them into stylish items of furniture. We use only eco-friendly materials, with no plastic and the wood is always top quality from reliable sources that do not cause deforestation or endanger rare trees under threat. Effe's extraordinary know-how translates into precise made-to-measure solutions.

## GENERATORE DI VAPORE INTERNO

## INTERNAL STEAM GENERATOR

Touch-screen control panel  
Pannello di controllo touch

Built-in steam generator  
Generatore ad incasso

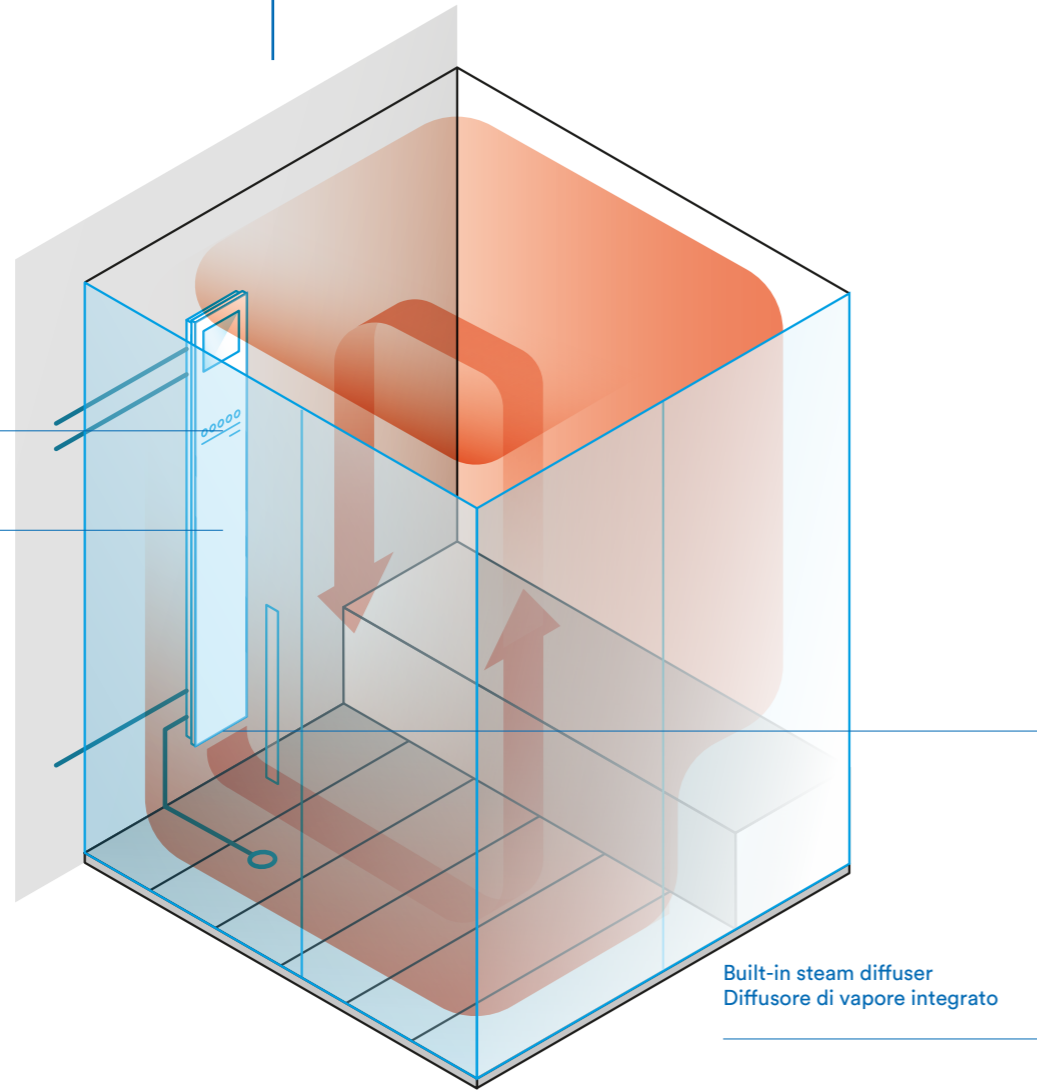
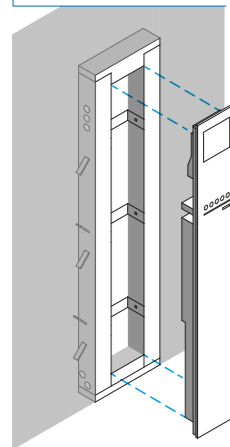

Built-in steam diffuser  
Diffusore di vapore integrato

### ELEGANTE

I generatori di vapore Effe sono compatti ed eleganti: il design razionale li rende adatti all'applicazione in qualsiasi ambiente.

### STYLISH

Effe steam generators are compact and stylish, designed to adapt perfectly to almost any environment and décor.

### FACILE DA INSTALLARE

Effe fornisce una controcassa perfettamente organizzata, per un veloce collegamento alle tubature e alla rete elettrica.

### EASY TO INSTALL

Effe supplies a perfectly designed outer casing for quick connection to the water and electrical mains.

## GENERATORE DI VAPORE ESTERNO

## EXTERNAL STEAM GENERATOR

External steam generator  
Generatore di vapore esterno

Chromotherapy lamp  
Lampada per cromoterapia

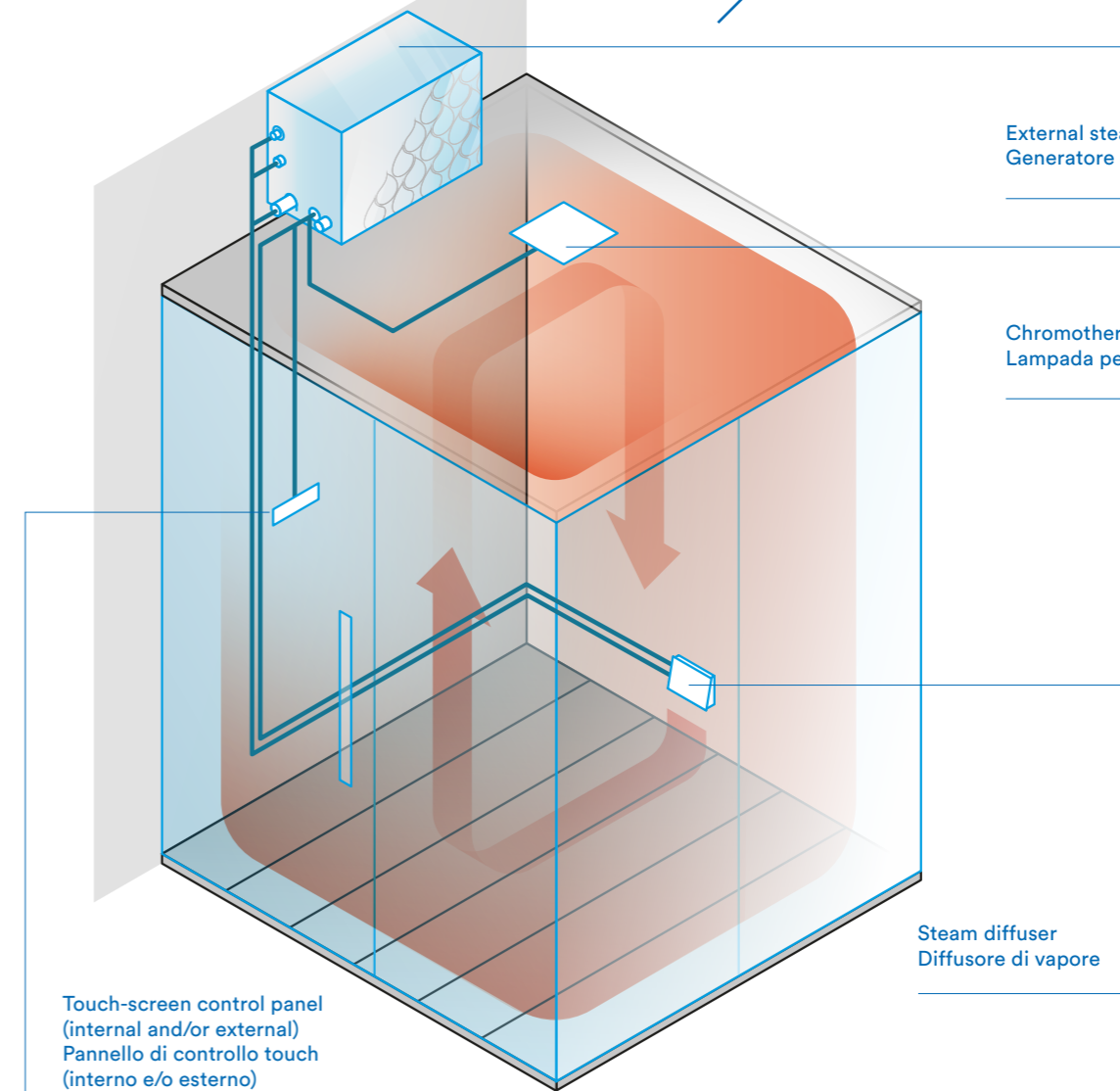

Steam diffuser  
Diffusore di vapore

Touch-screen control panel  
(internal and/or external)  
Pannello di controllo touch  
(interno e/o esterno)

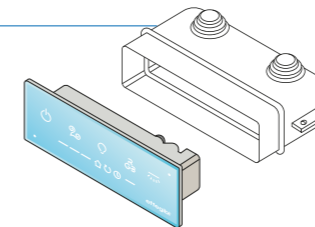

### POTENTE

Il generatore di vapore esterno Nuvola Smart Power permette l'utilizzo di motori più potenti e quindi l'utilizzo per spazi molto ampi.

### POWERFUL

The external Nuvola Smart Power steam generator enables more powerful motors to be fitted for use in much larger spaces.

### PULIZIA FORMALE

Il generatore esterno può essere installato in un vano nascosto, lasciando completa libertà nel design dell'hammam.

### DESIGN FREEDOM

The external generator can be installed in a hidden space, for total Hammam design freedom.

## ELEMENTI INDISPENSABILI PER UN HAMMAM DI QUALITÀ

## ESSENTIAL ELEMENTS FOR A QUALITY HAMMAM

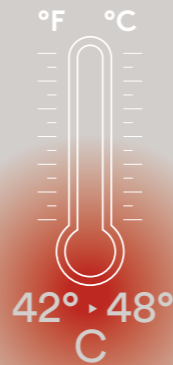
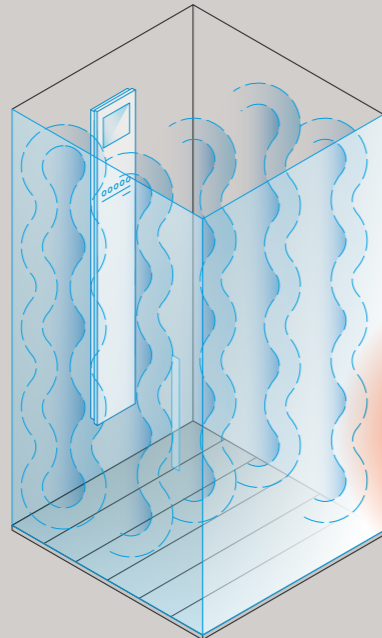

1

### DENSITÀ E TEMPERATURA DEL VAPORE

Un perfetto hammam si ottiene quando il vapore consente di raggiungere una temperatura superiore ai 40°C. Nei prodotti Effe la temperatura è programmabile in una scala che va dai 42 ai 48°C. La sapiente gestione del vapore, frutto di anni di ricerca, ottimizza l'omogeneità e la densità del calore all'interno del bagno turco.

### STEAM DENSITY AND TEMPERATURE

A perfect Hammam is achieved when the steam makes it possible to reach a temperature above 40°C. In Effe products the temperature can be set on a scale from 42 to 48°C. The smart steam management system, the fruit of many years of R&D, ensures even heat distribution and density inside the steam bath.

2

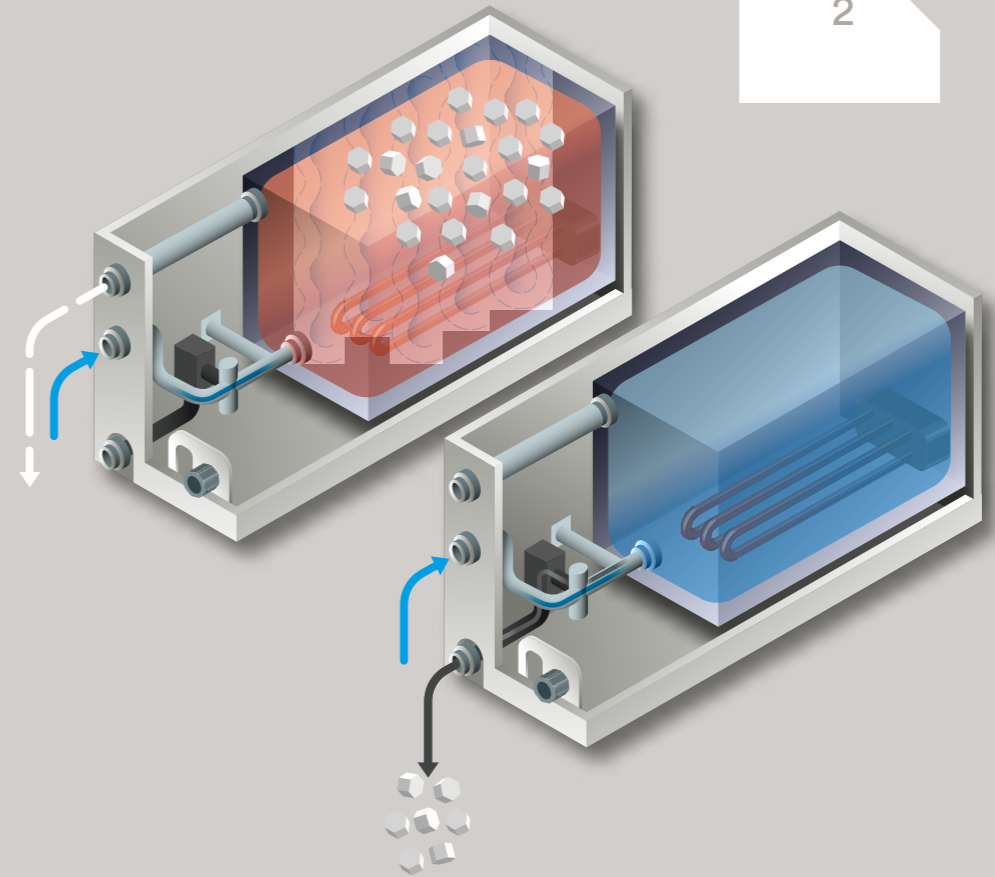

### CALCARE E IGIENE

La tecnologia esclusiva Effe, unica al mondo, consente di evitare filtri meccanici sul generatore e manutenzioni frequenti. Grazie a sistemi sofisticati, la caldaia (rigorosamente in acciaio inox) viene caricata e scaricata con acqua fredda e pulita a ogni utilizzo. Questo riduce notevolmente la necessità di interventi di pulizia e manutenzione, oltre a garantire una perfetta igiene all'interno dell'ambiente.

### LIME SCALE AND HYGIENE

Exclusive Effe technology has produced a unique system without mechanical filters on the generators and no need for frequent maintenance. All the boilers are stainless steel and a sophisticated system fills and empties the boiler with clean cold water every time it is used. This notably reduces the need for cleaning and maintenance, as well as ensuring the interior environment is perfectly hygienic.

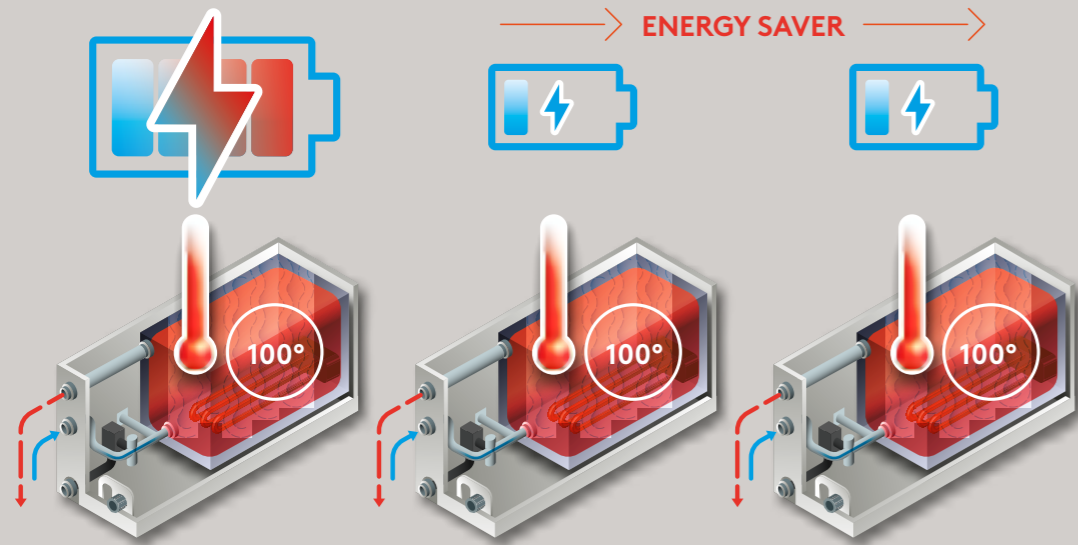

#### GESTIONE OTTIMIZZATA DEL CONSUMO ENERGETICO

Ogni generatore di vapore Effe è dotato di una funzione Energy Saver. La potenza massima del generatore viene sfruttata per portare in ebollizione l'acqua e raggiungere la temperatura impostata. Durante il funzionamento l'assorbimento viene ridotto alla metà o anche a un terzo, a seconda del modello di prodotto, pur mantenendo costante il getto di vapore.

#### OPTIMISED MANAGEMENT OF ENERGY CONSUMPTION

Each Effe steam generator has an Energy Saver function. The maximum power of the generator is used to bring the water to boiling point and reach the set temperature. While it is functioning the energy input is reduced to a half or a third, depending on the model, while keeping the steam flow constant.

## PSF: POWER STEAM FUNCTION

#### TRADITIONAL HAMMAM

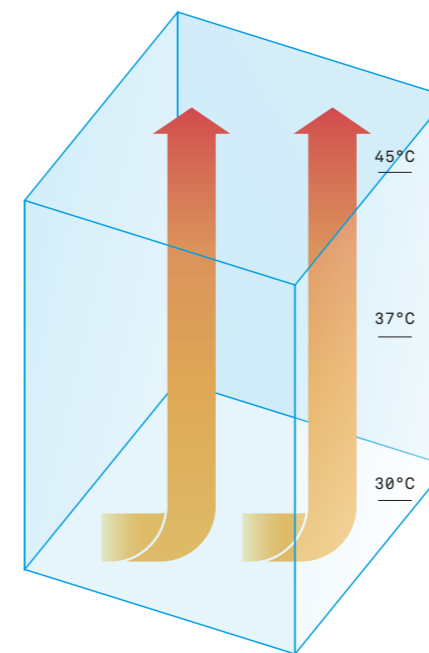

L'innovativo sistema di gestione della ventilazione minimizza la stratificazione delle temperature all'interno della cabina. In questo modo il calore dentro l'hammam sarà uniforme sia nella parte superiore che in quella inferiore dell'ambiente, condizione indispensabile per una salutare fruizione del bagno turco.

#### PSF: NEW TECHNOLOGY FROM EFFEGIBI

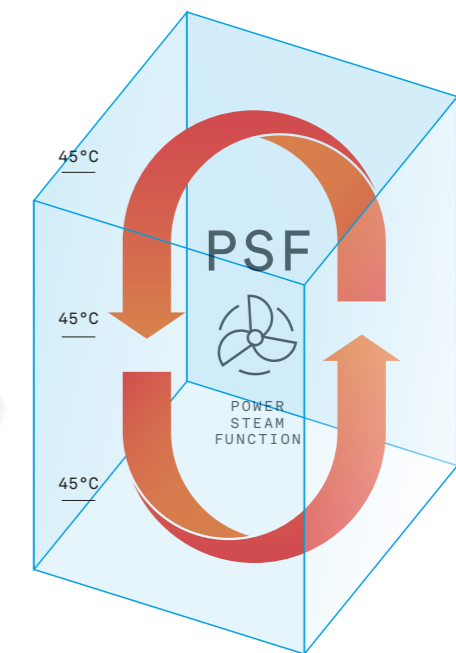

The innovative ventilation management system minimises temperature layering inside the cubicle. In this way the heat will be distributed evenly at the top and bottom of the Hammam, ensuring maximum benefits from the steam bath.

## LA SCELTA DI GENERATORI DI VAPORE EFFE

### YOUR CHOICE OF EFFE STEAM GENERATORS

HAMMAM SIZE

90<sup>m<sup>3</sup></sup>  
AND MORE

NUVOLA SMART POWER

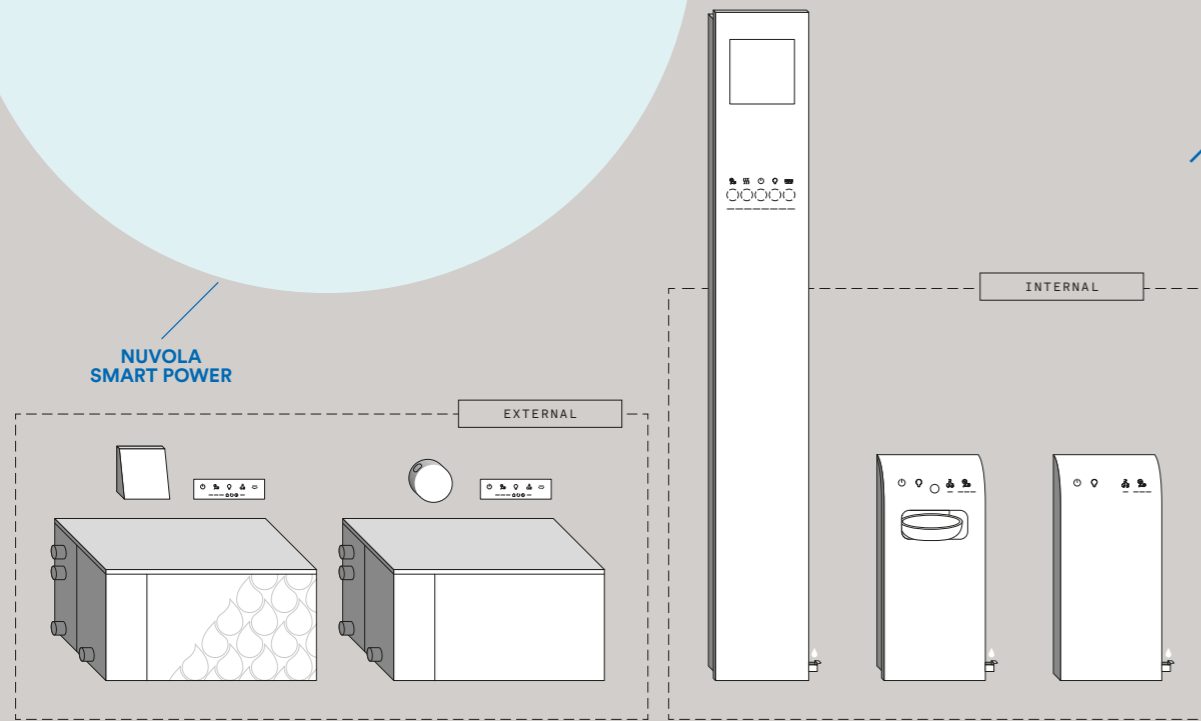

NUVOLA

TOUCH&STEAM

AQUASTEAM

EASYSYSTEM

MAX  
9,2<sup>m<sup>3</sup></sup>

HAMMAM SIZE

MAX  
4,5<sup>m<sup>3</sup></sup>

HAMMAM SIZE

## KNOW-HOW & TECHNOLOGY

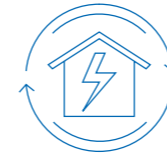

### SEC Smart Energy Control

Evenly spaced on/off periods for the heating elements to obtain even steam distribution throughout the session.

Distribuzione uniforme nel tempo dei cicli di accensione e spegnimento delle termoresistenze in modo da ottenere una diffusione di vapore costante.

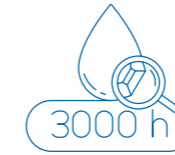

### SBC Smart Boiler Cleaning

Dilution and intermediate rinsing processes not time controlled but based on real need to reduce limescale deposits and avoid frequent boiler maintenance.

Diluizioni e risciacqui intermedi calcolati sul reale fabbisogno per ridurre l'accumulo di calcare e aumentare la durata della caldaia senza manutenzione.



### SWF Smart Water Filling

Optimised management of boiler filling, intermediate rinsing and emptying process. Heating elements programmed for optimum operation.

Gestione ottimizzata di riempimento caldaia, risciacqui intermedi e svuotamento. Le resistenze lavorano sempre in maniera ottimale.



### ECC Effe Comfort Control

This system is built into the Effe steam generator, enabling remote control of the Turkish bath from a tablet or smartphone using the Effegibi Experience app.

Il sistema è integrato nel generatore di vapore Effe e consente di gestire a distanza il bagno turco tramite l'App Effegibi Experience su tablet o smartphone.



### RWF Regulating Water Flow

The generator can work on a wide range of water systems with different pressures, from 0.2 bar to 10 bar.

Il generatore può lavorare dentro un ampio range di pressione dell'impianto idrico del locale: da 0,2 bar a 10 bar.

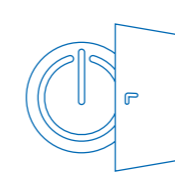

### ODS Open Door Sensor

The sophisticated electronics allow the generator to sense when the door is open and automatically block steam generation.

Grazie alla sofisticata elettronica il generatore comprende quando la porta è aperta e blocca in automatico la produzione del vapore.

NUVOLA SMART POWER

NUVOLA

TOUCH&STEAM

AQUASTEAM

EASYSYSTEM

SEC - SMART ENERGY CONTROL							
SBC - SMART BOILER CLEANING							
SWF - SMART WATER FILLING							
ECC - EFFE COMFORT CONTROL							
RWF - REGULATING WATER FLOW							
ODS - OPEN DOOR SENSOR							
PSF - POWER STEAM FUNCTION							
TOUCH CONTROLS							
AROMATHERAPY							
RGB CHROMOTHERAPY							
FOUNTAIN							

Se stai pensando di ristrutturare il bagno o devi ancora realizzarlo puoi trasformare molto facilmente il tuo box doccia in una cabina doccia con bagno turco. Le dimensioni di un box doccia con bagno turco possono essere quelle standard; l'altezza invece non dovrebbe superare i 230 cm per non sprecare energia e perché il vapore dell'hammam tenderebbe a salire troppo. Se invece hai a disposizione più spazio, puoi progettare il tuo angolo di relax pensando al numero di persone che ne usufruiranno.

Il segreto per realizzare il bagno turco ideale a casa propria è l'utilizzo di una perfetta coibentazione della porta, in modo che il vapore sia isolato all'interno, mentre viene garantito il giusto ingresso di aria dall'esterno. Effe ha studiato una serie di porte professionali da applicare alla cabina doccia, per mantenere costante la densità del vapore e ridurre i consumi.

**TRASFORMA  
LA TUA  
DOCCIA  
IN HAMMAM**

If you're thinking of refurbishing your bathroom, or about to build a new one, you can transform an ordinary shower cubicle into a luxury space complete with steam bath.

A shower cubicle incorporating a steam bath can still be a standard size, although the height must not exceed 230cm so as not to waste energy and because the steam in the Hammam will tend to rise too high.

**TRANSFORM  
YOUR SHOWER  
INTO A  
HAMMAM**



Hotel Rosa Alpina - San Cassiano - Bolzano - Italy

If you're lucky enough to have a bit more room, you can plan your chill-out space for more than one person.

The secret to creating your dream steam bath at home is perfect door insulation to ensure that the steam stays inside while the right amount of air flows in from outside. Effe has designed a range of professional-standard doors that can be fitted to your shower cubicle to keep steam density constant and reduce consumption.

## TRASFORMA LA TUA DOCCIA IN HAMMAM

## TRANSFORM YOUR SHOWER INTO A HAMMAM

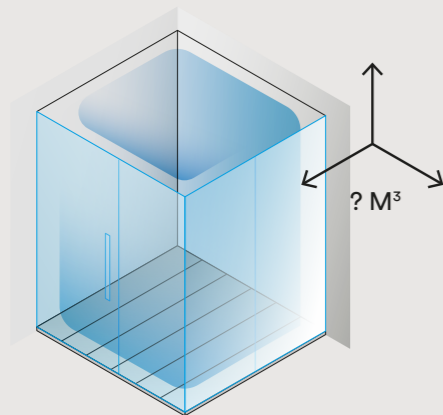

### Misura lo spazio che hai a disposizione

Ogni vano può essere trasformato in hammam, basta seguire alcune indicazioni su come coibentare pareti e porte. Molto importante è definire i metri cubi destinati ad ospitare l'hammam perchè esistono differenti generatori di vapore che variano in base alla potenza.

### Measure your available space

Any space can be transformed into a Hammam, just follow a few instructions for insulating walls and doors. It is very important to measure the volume that will play host to the Hammam so as to ensure the right steam generator is selected, based on its power.

### Scegli il generatore di vapore

Steam generators can be placed inside or outside the Hammam cubicle. You can base your choice on the available volume and also on your design preferences: Touch&Steam, Easystem and Aquasteam are stylish and easily adaptable to your own interior décor. They also have different functions that you can find out about in more detail on Page 40

### Choose the right steam generator

I generatori di vapore possono essere posizionati all'interno o all'esterno del vano hammam. Scegli in base ai metri cubi disponibili, oppure anche in base alle tue preferenze estetiche: Touch&Steam, Easystem e Aquasteam sono eleganti e adattabili facilmente allo stile del tuo arredo. Hanno anche funzioni differenti, che puoi scoprire nel dettaglio a pagina 40

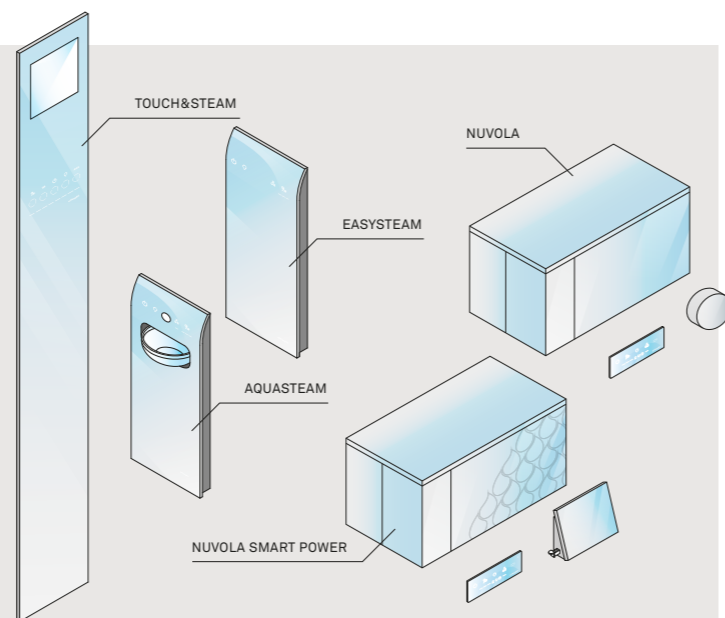

### Aggiungi il kit coibentazione e scegli una porta Effe per hammam

Per realizzare il bagno turco ideale è consigliata una perfetta coibentazione del vano. Le porte Effe garantiscono tenuta al vapore e un corretto ingresso e ricambio di aria.

### Add the insulation kit and choose an Effe Hammam door

Proper cubicle insulation is recommended for the perfect steam bath. Effe doors provide an efficient steam seal and correct air inflow and exchange.

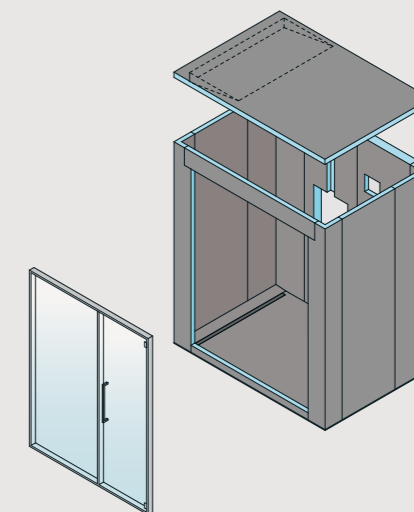

### Completa con arredi e accessori

Effe makes it possible to personalise your shower-Hammam with a set of handy accessories: benches, seats, water springs, chromotherapy, the ESS - Effe Sound System for listening to music inside the Hammam.

### Complete with furniture and accessories

Effe permette di personalizzare la tua doccia-hammam con una serie di utili accessori: panche, sedute, fonti per acqua, cromoterapia, ESS - Effe Sound System per l'ascolto della musica all'interno della cabina.

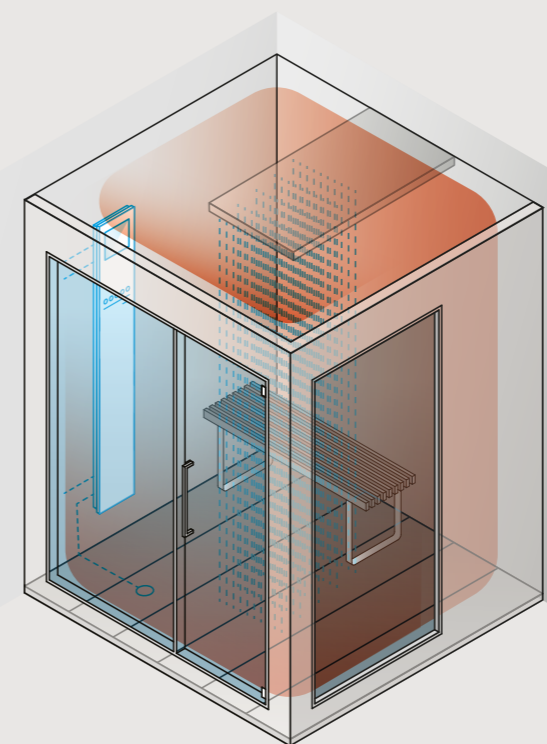

Il legno, per essere utilizzato nella sauna, deve avere precise caratteristiche di assorbimento del calore e di resistenza allo stress causato dagli sbalzi di temperatura.

Effe effettua internamente tutti i test necessari per garantire che i materiali siano adeguati per durare nel tempo e che rispettino le caratteristiche estetiche necessarie a realizzare saune perfette. Dall'hemlock canadese al tradizionale abete di Svezia, più di dieci tipologie di legno esclusivamente di prima scelta vengono selezionate da Effe e sottoposte a rigorosi controlli di qualità per offrire uno standard di altissimo livello qualitativo.

Nelle saune Effe non vengono mai utilizzati componenti plastici, poiché a temperature elevate potrebbero rilasciare sostanze nocive. I legni naturali garantiscono un ambiente sano, piacevole al tatto, che resta a lungo inalterato.

Wood to be used in a sauna must have specific properties of heat absorption and resistance to stress caused by temperature fluctuations. Effe carries out all the necessary tests in-house to guarantee the materials are capable of long life and that they meet all the aesthetic needs of a perfect sauna.

#### LA SCELTA DEL LEGNO PER LE SAUNE EFFE

#### THE CHOICE OF WOOD IN EFFE SAUNAS



Canadian Hemlock wood

From Canadian hemlock to the traditional Swedish pine, over ten different types of wood, always of top quality, are selected by Effe and subjected to rigorous quality control to ensure the highest possible quality standard.

Plastic components are never used in Effe saunas because at high temperatures they can emit noxious substances. Natural wood guarantees a healthy environment, is pleasant to the touch and is not altered over time.



Ogni articolo Effe è sottoposto a verifiche qualitative sia sotto l'aspetto estetico che funzionale. La sicurezza dei prodotti Effe è certificata a livello internazionale dai principali marchi di qualità che garantiscono il rispetto delle più severe normative vigenti. I reparti interni Effe di produzione e di Ricerca&Sviluppo, garantiscono sempre una produzione personalizzata e di alto profilo professionale.



**LE CERTIFICAZIONI  
NAZIONALI  
E INTERNAZIONALI**

**NATIONAL AND  
INTERNATIONAL  
CERTIFICATIONS**

All Effe products are subject to quality checks in terms of both their aesthetics and functions. The safety of Effe products is certified by all the leading international certification bodies to guarantee compliance with the most rigorous current standards. The Effe in-house technology R&D and production departments guarantee a highly professional personalised service.



Touch controls



Effe in-house technology R&D

# effe

BY EFFEGIBI

**Effegibi**  
Via Gallo 769  
47522 Cesena (FC)  
Italy  
tel +39 0547 372881  
www.effegibi.it

The images and data contained in this catalogue are merely a guide and may be changed at any time without notice.

Effegibi: all rights reserved  
Total or partial reproduction of the text or illustrations in this catalogue is prohibited and subject to legal sanctions.

**Thanks to:**  
Lea Ceramiche  
Ceramiche Mutina  
Ceramica Sant'Agostino  
Fratelli Fantini  
Falper  
Spencer Contract

**Special thanks to:**  
casaFantini / lake time, Lago d'Orta  
Excelsior Hotel Gallia, Milano  
Golfo dei Poeti Relais, Ameglia  
La Casa del Porto, Lovere  
Relais & Châteaux Rosa Alpina, San Cassiano  
Tenuta Le Cave, Tregnago  
Terme di Arta, Udine

**Art direction & graphic design:**  
Zup Design

**Photo:**  
Simone Casetta  
Massimo Spada  
(8>15;177>181;332)  
Archivio Effegibi  
(33>37;42;43;52>55;58;59;78;79;107>109;  
127;143;169>171;182;183;215>217;279;  
280;295;296;301>303;309;327;329)



**effe**

BY EFFEGIBI

**Effegibi**  
Via Gallo 769  
47522 Cesena (FC)  
Italy  
[www.effegibi.it](http://www.effegibi.it)