

2020

Catálogo Geral _ General Catalogue
Catalogue Général _ Catálogo General

revigres

the art of storytiling

HISTÓRIAS QUE REVESTEM O MUNDO

revigres

The art of storytiling

Histórias que revestem o mundo

É no chão que começamos a gatinhar e a dar os primeiros passos. Jogamos às escondidas nas paredes. Nas varandas e pátios, descobrimos os nossos horizontes. Na cozinha, aprendemos os segredos das avós. As casas de banho servem de refúgio para as primeiras dúvidas na adolescência. Os corredores servem para confidências com os nossos melhores amigos. O nosso quarto será sempre o nosso porto seguro. As salas de estar serão para sempre salas para conviver. As salas de reuniões transformam-se em espaços para criar. Os aeroportos em segundas casas. E nas cidades cabe a nossa imaginação.

A Revigrés está presente em todos estes momentos, revestindo as nossas vidas com qualidade, conforto, beleza e inovação, fazendo parte de todas as nossas histórias, hoje e no futuro.

The Art of Storytiling

It is on the floor that we begin to crawl and take our first steps. We play hide-and-peek against the walls. On balconies and in yards, we discover our horizons. In the kitchen, we learn our grandmothers' secrets. Bathrooms act as a refuge for the first doubts of adolescence. In the corridors we exchange secrets with our best friends. Our bedroom will always be our safe haven. Living rooms will forever be places for enjoying life. Meeting rooms become places for creating. Airports become second homes. And cities accommodate our imagination.

Revigrés is present in all these moments coating our lives with quality, comfort, beauty and innovation and taking part of all our stories, today and in the future.

Des histoires qui habillent le monde

C'est sur le sol que nous faisons nos premiers pas à quatre pattes. Nous jouons à cache-cache entre les murs. Nous découvrons de nouveaux horizons sur les balcons et les terrasses. Dans la cuisine, nous apprenons les secrets de grand-mère. Les salles de bains servent de refuge pour les premiers doutes de l'adolescence. Les couloirs abritent les confidences partagées avec nos meilleurs amis. Notre chambre sera toujours notre port d'abri. Les salons seront toujours des pièces où il fait bon vivre. Les salles de réunion deviennent des lieux de créativité, et les aéroports des résidences secondaires. Et dans les villes règne notre imagination.

Revigrés est présente dans tous ces moments-là, habillant nos vies avec qualité, confort, beauté et innovation; elle fait partie de toutes nos histoires, aujourd'hui et à l'avenir.

Historias que revisten el mundo

Sobre el suelo empezamos a gatear y damos nuestros primeros pasos. Jugamos al escondite en las paredes. En los balcones y patios descubrimos nuestros horizontes. En la cocina, aprendemos los secretos de las abuelas. Los cuartos de baño sirven de refugio para las primeras dudas en la adolescencia. Los pasillos sirven para confidencias con nuestros mejores amigos. Nuestra habitación será siempre nuestro lugar seguro. Los salones serán para siempre espacios para vivir. Las salas de reuniones se transforman en espacios para crear. Los aeropuertos en segundas casas. Y en las ciudades cabe nuestra imaginación.

Revigrés está presente en todos estos momentos, revistiendo nuestras vidas con calidad, confort, belleza e innovación, formando parte de todas nuestras historias, hoy y en el futuro.



Índice Geral

General Index _ Index Générale _ Índice General

Índice Geral

General Index _ Index Générale _ Índice General

	Página Page Page Página
A Portuguese Touch – Introdução _ Introduction _ Introduction _ Introducción	010
Um Parceiro para o seu Projeto _ A Partner for your Project _ Un Partenaire pour votre Projet _ Un Socio para su Proyecto	016
Revigrés Online _ Revigrés Online _ Revigrés en Ligne _ Revigrés Online	018
Declaração Ambiental _ Environmental Declaration _ Déclaration Environnementale _ Declaración Ambiental	020
Produtos Revigrés _ Revigrés Products _ Produits Revigrés _ Productos Revigrés	022
Coleções	
Collections _ Collections _ Colecciones	
Full Body _ Toda a Massa _ Pleine Masse _ Todo Masa	026
Ecotiles	086
Metallic	096
Colors	114
Reliefs	144
Concrete	162
Marbles	218
Stones	264
Wood	300
Rustic	342
Decorados, Listelos e Barras _ Decors, Listels and Bars _ Decors, Listels et Frises _ Decorados, Listeles y Barras	354
Multifunctional Projects	
Projetos Multifuncionais _ Projets Multifonctionnels _ Proyectos Multifuncionales	362
A Partner for Your Project	
Projetos _ Projects _ Projets _ Proyectos	378
Useful Information	
Informações Úteis _ Informations Utiles _ Información Útil	394
Peças Complementares _ Fittings _ Pieces Speciales _ Piezes Suplementarias	396
Ícones _ Icons _ Icones _ Iconos	398
Acabamento _ Finish _ Finition _ Acabado	402
Calibres _ Calibres _ Calibres _ Calibre	403
Assentamento e Manutenção _ Tile Laying and Maintenance _ Pose et Entretien _ Asentamiento y Mantenimiento	404
Embalagens e Pesos _ Packing List and Weights _ Emballages et Poids _ Embalajes y Pesos	413
Características Técnicas _ Technical Characteristics _ Caractéristiques Techniques _ Características Técnicas	416
Certificados _ Certificats _ Certificats _ Certificados	420

Índice de Coleções

Index by Collections _ Index par Collections _ Índice por Colecciones

Coleção Collection Collection Colección	Página Page Page Página	Tipologia Typology Typologie Tipologia	7,5 x 30 cm	10 x 10 cm	20 x 40 cm	30 x 45 cm	30 x 60 cm	30 x 90 cm	30 x 30 cm	45 x 45 cm	60 x 60 cm	15 x 60 cm	15 x 75 cm	45 x 90 cm	90 x 90 cm	15 x 120 cm	19,5 x 120 cm	30 x 120 cm	60 x 120 cm	19,5 x 180 cm	30 x 180 cm	Ver também See also Voir aussi Ver también	
Absolut Black	228						♦				♦				♦							220, 224, 225	
Afyon	266						♦				♦								♦				
Antiderrapante Saturno	94								♦														92
Antislip Afyon	268										♦												
Antislip Forest	334												♦										209, 245
Antislip Globe	206										♦												
Antislip Urban	212										♦												
Arizona	346									♦													
Atelier	194						♦																
Baltic Grey NEW	220						♦				♦				♦								147, 305
Bianco	240						♦	♦											♦				
Branco Mate	135								♦														
Cityzen NEW	164						♦				♦			♦	♦								120
Copper	108						♦				♦												
Cromática _ Chromatic	28		♦				♦		♦		♦				♦				♦				35, 49, 51, 99, 138, 139, 153
Deck	326																♦						155, 274
Deck Forest	338												♦										
Deck Smart	330																						
Dual	72						♦		♦		♦												78, 79
Ecotech	90									♦													88
Edicer Pedralva	350									♦													
Edicer Santana	348									♦													
Elements	172										♦			♦	♦								
Elements NEW	178						♦	♦															173
Emperador Brown	232						♦				♦				♦								
Espelho / Mirror	98						♦																
Exotic	320																♦	♦	♦				108, 159, 185, 191, 195, 203
Flash	150							♦															
Flick	150							♦															
Flint	56						♦		♦	♦	♦	♦		♦	♦					♦			71, 136, 240
Forest	334												♦										125, 188, 209, 254, 341, 345
Fórum	344						♦																
Globe	182						♦				♦			♦	♦								152, 189, 191, 195, 241, 320
Hydraulik	216									♦													124, 211
illusion	138					♦																	
Impressions	208						♦																196, 209, 335
Iron	109						♦				♦												111, 113
Java	84								♦														81
Jinko	314															♦	♦	♦					129, 213, 233, 250, 277, 286

Índice de Coleções

Index by Collections _ Index par Collections _ Índice por Colecciones

Coleção Collection Collection Colección	Página Page Page Página	Tipologia Typology Typologie Tipologia	7,5 x 30 cm	10 x 10 cm	20 x 40 cm	30 x 45 cm	30 x 60 cm	30 x 90 cm	30 x 30 cm	45 x 45 cm	60 x 60 cm	15 x 60 cm	15 x 75 cm	45 x 90 cm	90 x 90 cm	15 x 120 cm	19,5 x 120 cm	30 x 120 cm	60 x 120 cm	19,5 x 180 cm	30 x 180 cm	Ver também See also Voir aussi Ver también	
Lavastone	274						♦				♦			♦	♦								255
Minimal	194						♦																195
MixForms NEW	146								♦														303
MixPeak NEW	147								♦	♦													164
MixStep NEW	148								♦														99
Moka	258								♦	♦				♦									
Nimbus	202								♦	♦													196, 199, 334
Nordik NEW	303															♦	♦	♦		♦	♦		116, 117, 146, 310, 326
Nordik Lines NEW	310										♦												
Onix	254								♦	♦				♦									
Oxford	128		♦																				
Penha	352													♦									
Pigmento	82													♦									80
Planet	196																						205
Pulpis	244														♦	♦			♦				
Retro NEW	120					♦																	
Revival	124						♦																121
Saturno	94																						93
Season NEW	116									♦													
Silken	188									♦													
Slate	286																			♦			
Solids	208										♦												205, 334
Stampa	340										♦												
Statuario White	224														♦								233, 302
Táteis _ Tactile	52																						
Tetris	152														♦								
Traffic	158														♦								
Tuscania	250																						
Unicolor	132								♦	♦	♦	♦											147
Urban	210														♦	♦	♦	♦					121, 132, 133, 155
Venezia Bianco	236																						315
Vogue NEW	102															♦	♦						105
Wave	150														♦								
Xisto	292																						
Yura	282																						

Índice por Estilo

Index by Style _ Index par Effet _ Índice por Estilo



Toda a massa Full-body Pleine Masse Todo Masa

Cromática	028
Dual	072
Flint	056
Java	081
Pigmento	080
Táteis / Tactile	052

Página
Page
Page
Página



Ecotiles

Ecotech	088
Saturno	092



Metallic

Copper	108
Espelho / Mirror	098
Iron	109
Vogue	102

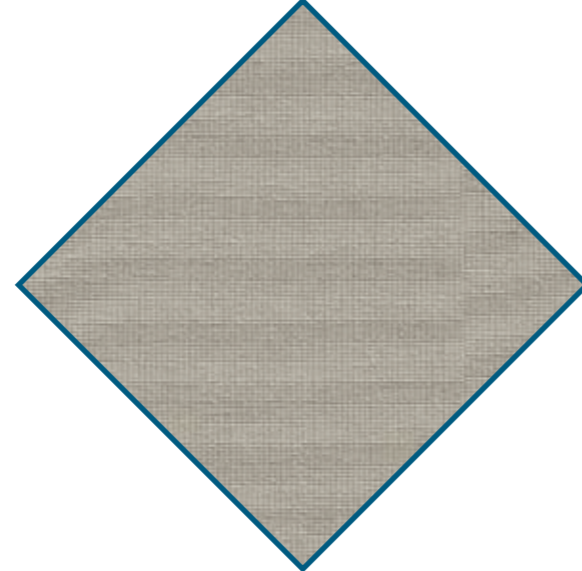

Colors

illusion	138
Oxford	128
Retro	120
Revival	124
Season	116
Unicolor	132

Página
Page
Page
Página

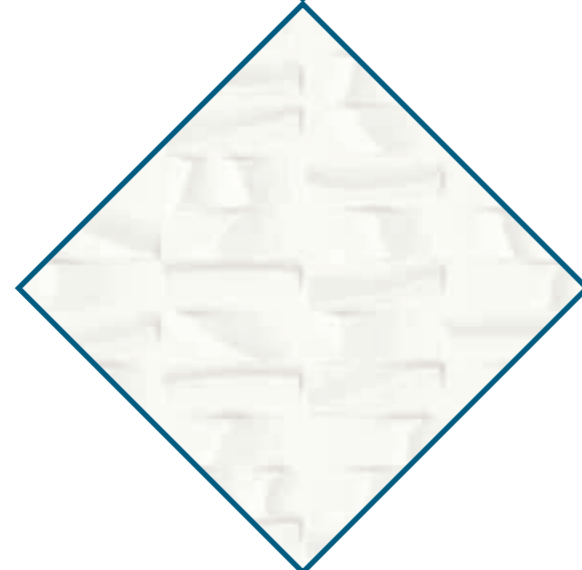

Reliefs

Flash	150
Flick	150
MixForms	146
MixPeak	148
MixStep	147
Tetris	152
Traffic	158
Wave	150



Concrete

Cityzen	164
Elements	172
Globe	182
Nimbus	202
Planet	196
Silken	188
Urban	210

Página
Page
Page
Página

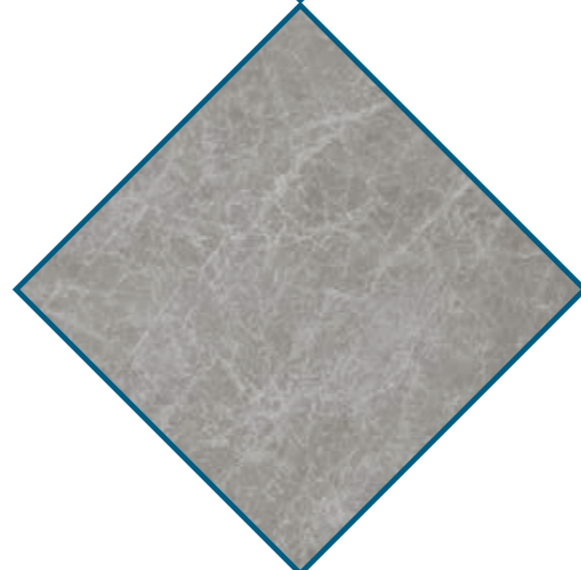

Marbles

Absolut Black	228
Baltic Grey	220
Bianco	240
Emperador Brown	232
Moka	258
Onix	254
Pulpis	244
Statuario White	224
Tuscania	250
Venezia Bianco	236



Stones

Afyon	266
Lavastone	274
Slate	286
Xisto	292
Yura	282

Página
Page
Page
Página



Wood

Deck	326
Deck Forest	338
Deck Smart	330
Exotic	320
Forest	334
Jinko	314
Nordik	303
Nordik Lines	310
Stampa	340



Rustic

Arizona	346
Edicer Pedralva	348
Edicer Santana	350
Fórum	344
Penha	352

A Portuguese Touch



Um Toque Português

Constituída em 1977, a Revigrés produz revestimentos e pavimentos em grés porcelânico, revestimentos e pavimentos em grés porcelânico esmaltado e revestimentos cerâmicos vidrados, ocupando uma posição de liderança no setor cerâmico.

Mais de 40 anos dedicados ao desenvolvimento de soluções de cerâmica inovadoras e de design exclusivo, que dão vida aos espaços, com o selo de qualidade de uma empresa 100% portuguesa.

A Portuguese Touch

Founded in 1977, Revigrés produces full body porcelain wall and floor tiles, glazed porcelain wall and floor tiles and glazed ceramic wall tiles, occupying a leading position in the ceramics industry.

It has dedicated more than 40 years to developing innovative ceramic solutions with a unique design, which bring spaces to life, with the quality seal of a 100% Portuguese owned company.

Une Touche Portugaise

Fondée en 1977, Revigrés produit de la faïence en pâte blanche, du grés cérame émaillé et du grés cérame pleine masse, occupant une position de leader dans la filière de la céramique.

Plus de 40 années consacrées au développement de solutions en céramique innovantes et au design exclusif qui confèrent de la vivacité aux espaces, avec le label de qualité d'une société 100% portugaise.

Un Toque Portugués

Creada en 1977, Revigrés produce revestimientos y pavimentos de grés porcelánico, revestimientos y pavimentos de grés porcelánico esmaltado, y revestimientos cerámicos vidriados, y ocupa una posición de liderazgo en el sector cerámico.

Más de 40 años dedicados al desarrollo de soluciones de cerámica innovadoras y con un diseño exclusivo, que dan vida a los espacios, con el sello de calidad de una empresa 100 % portuguesa.



Álvaro Siza Vieira
arquitecto_architect

O edifício comercial da Revigrés – inaugurado em 1997 – é um projeto do Arquitecto Álvaro Siza Vieira, o primeiro vencedor do Prémio Pritzker, em Portugal.

The commercial building of Revigrés – opened in 1997 – was designed by Architect Álvaro Siza Vieira, the first architect to have received the Pritzker Prize in Portugal.

Le bâtiment commercial Revigrés – inauguré en 1997 – est un projet de l'architecte Álvaro Siza Vieira, premier lauréat du prix Pritzker au Portugal.

El edificio comercial de Revigrés – inaugurado en 1997 – es un proyecto del arquitecto Álvaro Siza Vieira, el primer Premio Pritzker portugués.

A Portuguese Touch



Vestido "Caravela de Azulejos"
"Tile Caravel" dress

O vestido "Caravela de Azulejos" da dupla de estilistas Storytailors - uma verdadeira obra de arte que exhibe peças da Coleção Cromática - já foi a estrela de exposições e eventos de moda internacionais.

Quem não conhece o patrocínio da Revigrés ao FC Porto? Com 37 anos consecutivos, este foi o 1º patrocínio de uma empresa portuguesa a um clube de futebol e é já o mais duradouro a nível mundial.



Painel dos Fundadores, Mestre Júlio Resende, Estádio do Dragão (FC Porto)
Founders' Panel - Painter Júlio Resende, Dragon Stadium (FC Porto)

The dress "Tile Caravel" by fashion designers Storytailors, a true work of art with pieces of our Chromatic Collection, was the star at a series of international exhibitions and fashion events.

Who doesn't know that Revigrés sponsors FC Porto football club? Going on for 37 consecutive years, this was the 1st time a Portuguese company sponsored a football club and this is already the longest lasting sponsorship in the world.

La robe « Caravelle d'azulejos » dont les auteurs sont les deux grands couturiers Storytailors – une véritable œuvre d'art qui arbore des pièces de la collection Chromatique – attraction principale lors d'expositions et d'événements de mode internationaux.

Qui ne connaît pas le sponsoring de Revigrés au FC Porto ? 37 ans d'affilée, ce fut le premier parrainage d'une société portugaise à un club de football et c'est déjà le plus long au monde.

El vestido "Caravela de Azulejos" del dúo de estilistas Storytailors —una verdadera obra de arte que incluye piezas de la colección Cromática— ya se ha convertido en la estrella de exposiciones y eventos de moda internacionales.

¿Y quién no conoce el patrocinio de Revigrés al FC Porto? El primer patrocinio de una empresa portuguesa a un equipo de fútbol cumple ya 37 años consecutivos, lo que lo convierte en el más duradero del mundo.



Basilica La Sagrada Família, Barcelona, Espanha
Basilica La Sagrada Família, Barcelona, Spain

A Revigrés na Basílica La Sagrada Família, em Barcelona

A Revigrés tem vindo a desenvolver variadíssimas cores da Coleção Cromática, em exclusivo, para peças aplicadas no medalhão central, no interior, e nos pináculos exteriores da Basílica La Sagrada Família, em Barcelona. Já foram aplicadas 28 das mais de 50 cores desenvolvidas para o projeto.

A elevada flexibilidade de produção que a Revigrés sempre demonstrou na resposta a projetos personalizados foi determinante para os responsáveis da obra - arquiteto Jordi Fauli e escultor Etsuro Sotoo - na proposta, criação e desenvolvimento de cores específicas da Coleção Cromática.

Considerada a obra mais importante tanto de Gaudí como do movimento modernista na Catalunha e um símbolo da arquitetura barcelonesa, a Basílica La Sagrada Família é o monumento mais visitado em Espanha e um dos cinco pontos turísticos mais visitados do Mundo.

Revigrés in La Sagrada Família Basilica, in Barcelona

Revigrés has been developing new and exclusive colors from the Chromatic Collection used on the tiles of the central medallion inside the basilica, and the external pinnacles of La Sagrada Família, in Barcelona. We have already applied 28 of the more than 50 colours we developed for the project.

Great production flexibility, with which Revigrés has always responded to personalised projects, was decisive for architect Jordi Fauli and sculptor Etsuro Sotoo, in the proposal, creation and development of specific colours of the Chromatic Collection.

Considered the most important work of Gaudí and the modernist movement of Catalonia and a symbol of the architecture of Barcelona, La Sagrada Família basilica is at the top of the rank of Spain's monuments with the largest number of visitors and is one of the five most visited touristic places in the world.

Revigrés dans la Basilique La Sagrada Família, à Barcelone

Revigrés a mis au point, en exclusivité, une grande palette de couleurs de la Collection Chromatique, pour des pièces appliquées sur le médaillon central, à l'intérieur, et dans les pinacles extérieurs de la Sagrada Família à Barcelone. 28 parmi plus de 50 couleurs créées pour le projet ont déjà été appliquées.

La grande flexibilité de production dont Revigrés a toujours fait preuve pour répondre à des projets personnalisés a fortement pesé pour les responsables de l'œuvre - l'architecte Jordi Fauli et le sculpteur Etsuro Sotoo - dans la proposition, la création et le développement de couleurs spécifiques de la Collection Chromatique.

Considérée comme l'œuvre la plus importante de Gaudí et du mouvement moderniste en Catalogne et un symbole de l'architecture de Barcelone, la basilique La Sagrada Família est le monument le plus visité en Espagne et un des cinq sites touristiques les plus visités dans le Monde.

Revigrés en la basílica de la Sagrada Família, en Barcelona

Revigrés ha desarrollado, en exclusiva, colores muy variados de la colección Cromática para piezas aplicadas en el medallón central, en el interior y en los pináculos exteriores de la basílica de la Sagrada Família, en Barcelona. Ya se han aplicado 28 de los más de 50 colores desarrollados para el proyecto.

La gran flexibilidad de producción que Revigrés siempre ha demostrado en la respuesta a proyectos personalizados resultó determinante para los responsables de la obra, el arquitecto Jordi Fauli y el escultor Etsuro Sotoo, en la propuesta, creación y desarrollo de colores específicos dentro de la Colección Cromática.

Considerada la obra más importante tanto de Gaudí como del movimiento modernista en Cataluña y un símbolo de la arquitectura barcelonesa, la basílica de la Sagrada Família es el monumento con mayor número de visitantes en España y uno de los cinco lugares turísticos con mayor número de visitantes en el Mundo.

Design & Innovation



Showroom de Águeda
Águeda showroom _ Showroom Águeda _ Sala de exposición de Águeda



Showroom de Lisboa
Lisbon showroom _ Showroom à Lisbonne _ Sala de exposición de Lisboa



A Revigrés dispõe de showrooms na sede (Barrô, Águeda) e em Lisboa, com uma equipa atenta e um atendimento especializado.

Revigrés has a showroom at the head-office (Barrô - Águeda) and in Lisbon, managed by a dedicated team offering an expert service.

Revigrés dispose de showrooms dans son siège (Barrô - Águeda) et à Lisbonne, avec une équipe dévouée et un service spécialisé.

Revigrés cuenta con salas de exposición en su sede (Barrô - Águeda) y en Lisboa, en las que un equipo atento ofrece una atención especializada.

Qualidade Global

A Revigrés tem a quádrupla certificação dos seus sistemas de gestão integrados, nos seguintes referenciais: Qualidade; Ambiente; Responsabilidade Social; Investigação, Desenvolvimento e Inovação.

Global Quality

Revigrés has a four-time certification of its integrated management systems, in the following references: Quality; Environment; Social Accountability; Research, Development and Innovation.

Qualité Globale

Revigrés a la quadruple certification de ses systèmes de gestion intégrée, pour les référentiels suivants: Qualité; Environnement; Responsabilité Sociale; Recherche, Développement et Innovation.

Calidad Global

Revigrés posee el quádruple certificado de sus sistemas de gestión integrados en los siguientes ámbitos: calidad, medioambiente, Responsabilidad Social, Investigación y Desarrollo e Innovación.



Design e Inovação são as linhas que nos orientam em todos os projetos que desenvolvemos. Esta aposta tem merecido o reconhecimento do mercado nacional e internacional com a atribuição de várias distinções.

We are guided by Design and Innovation in all projects we develop. This focus has earned Revigrés national and international recognition, having been awarded many prizes.

Design et Innovation sont les lignes qui nous guident dans tous les projets que nous développons. Ce pari a mérité la reconnaissance du marché national et international avec l'attribution de plusieurs distinctions.

Diseño e Innovación son las directrices que nos guían en todos los proyectos que llevamos a cabo. Esta apuesta ha merecido el reconocimiento del mercado portugués e internacional a través de la concesión de varias distinciones.

A Partner for your Project

UM PARCEIRO PARA O SEU PROJETO

Presente em mais de 50 países, a Revigrés mantém uma relação de estreita parceria e colaboração com os profissionais no mercado nacional e internacional, sendo frequentemente selecionada para se associar a obras de grande impacto, para a realização de projetos especiais, personalizados e exclusivos.

A PARTNER FOR YOUR PROJECT

Present in more than 50 countries, Revigrés collaborates closely and in partnership with professionals in the domestic and international markets, and is often chosen to participate in major works, by developing special, personalised and unique projects.

UN PARTENAIRE POUR VOTRE PROJET

Présente dans plus de 50 pays, Revigrés entretient une relation étroite de partenariat et de collaboration avec les professionnels du marché national et international, étant souvent choisie pour s'associer à des ouvrages à fort impact, pour réaliser des modèles spéciaux, personnalisés et exclusifs.

UN SOCIO PARA SU PROYECTO

Presente en más de 50 países, Revigrés mantiene una estrecha relación de asociación y colaboración con los profesionales del mercado portugués e internacional, y resulta frecuentemente seleccionada para participar en obras de gran impacto, para la realización de proyectos especiales, personalizados y exclusivos.

Biblioteca de Objetos Bim

A Revigrés apresenta uma Biblioteca de Objetos BIM (Building Information Modelling), tornando-se na primeira empresa portuguesa do setor de revestimentos e pavimentos cerâmicos a associar-se a uma Metodologia que está a revolucionar o setor da arquitetura, engenharia e construção a nível internacional.

Através desta solução, os arquitetos e projetistas dispõem, num único ficheiro, de todas as informações sobre as referências das coleções Revigrés - a sua imagem estética, certificações associadas, informações técnicas e comerciais - que utilizam na modelação de edifícios virtuais, através de ferramentas tridimensionais.

Numa primeira fase, a Revigrés disponibiliza as 40 cores, 10 formatos e 3 acabamentos da Coleção Cromática - incluindo os formatos especiais CUBE, HALF, CHEVRON e TRIO - para além das barras, cantos e peças complementares que compõem a coleção.

A Biblioteca de objetos BIM da Revigrés (Coleção Cromática) está disponível em www.revigrés.com, sendo compatível com o software Autodesk Revit.

Apoio técnico através do email: bimsupport@revigrés.pt.

Bim Object Library

Revigrés introduces the BIM (Building Information Modelling) Object Library, hereby becoming the first Portuguese company in the ceramic tile industry to adhere to a Methodology that is revolutionising the architectural, engineering and building sectors globally.

This solution grants architects and designers access to information compiled in a single file for all references of the Revigrés collection - the aesthetic image, associated certifications, technical and commercial information - that they use to model virtual buildings using 3D tools.

Initially, Revigrés provides the 40 colours, 10 formats and 3 finishes of the Chromatic Collection - including the special formats CUBE, HALF, CHEVRON and TRIO - in addition to the bars, corners and complementary pieces that make up the collection.

Revigrés's BIM Object Library (Chromatic Collection) is available at www.revigrés.com, and it is compatible with Autodesk Revit.

To request technical support send an email to: bimsupport@revigrés.pt.

Bibliothèque D'objets Bim

Revigrés présente une Bibliothèque d'objets BIM (Building Information Modelling), devenant ainsi la première entreprise portugaise du secteur des revêtements de mur et de sol en céramique à s'associer à une méthodologie qui révolutionne le secteur de l'architecture, du génie civil et du bâtiment à l'international.

Grâce à cette solution, les architectes et les concepteurs disposent, dans un même fichier, de toutes les informations sur les références des collections Revigrés - leur image esthétique, les certifications y associées, les informations techniques et commerciales - qu'ils utilisent dans la modélisation de bâtiments virtuels au moyen d'outils tridimensionnels.

Dans un premier temps, Revigrés met à disposition les 40 couleurs, 10 formats et 3 finitions de la collection Cromática - y compris les formats spéciaux CUBE, HALF, CHEVRON et TRIO - en plus des frises, des angles et des pièces complémentaires qui composent la collection.

La bibliothèque d'objets BIM Revigrés (Collection Cromática) est disponible sur www.revigrés.com et est compatible avec le logiciel Autodesk Revit.

Soutien technique par le courriel: bimsupport@revigrés.pt.

Biblioteca de Objetos Bim

Revigrés presenta una biblioteca de objetos BIM (Building Information Modelling) y se convierte en la primera empresa portuguesa del sector de revestimientos y pavimentos cerámicos que se asocia a una metodología que está revolucionando el sector de la arquitectura, de la ingeniería y de la construcción a escala internacional.

A través de esta solución, los arquitectos y diseñadores disponen, en un único archivo, de toda la información sobre las referencias de las colecciones Revigrés - imagen estética, certificados asociados, información técnica y comercial - que utilizan en el modelado de edificios virtuales mediante herramientas tridimensionales.

En una primera fase, Revigrés ofrece los 40 colores, 10 formatos y 3 acabados de la colección Cromática - incluidos los formatos especiales CUBE, HALF, CHEVRON y TRIO - además de las barras, cantos y piezas complementarias que componen la colección.

La biblioteca de objetos BIM de Revigrés (colección Cromática) está disponible en www.revigrés.com y es compatible con el software Autodesk Revit.

Asistencia técnica en la dirección de correo electrónico: bimsupport@revigrés.pt.



EDIFÍCIO DE ESCRITÓRIOS DA COMPANHIA PETROLÍFERA BAKER HUGHES

Para esta obra, escolhemos pavimentos em grés porcelânico técnico da Revigrés. Por um lado, devido à sua elevada resistência, adequada para estas áreas de tráfego intenso; por outro, pelo seu efeito estético. Temos total confiança no nosso parceiro.

Jan Eimar Dalva
Diretor de Vendas de Projeto, Modena Tiles (Noruega)

OFFICE BUILDING OF THE BAKER HUGHES OIL COMPANY

In this project we chose Revigrés full body porcelain tiles for the floors. On the one hand, due to their high mechanical strength, suitable for high traffic areas and, on the other hand, the aesthetic effect. We fully trust our partner.

Jan Eimar Dalva
Project Sales Director, Modena Tiles (Norway)

A sua flexibilidade de produção permite à Revigrés ter uma capacidade impar de resposta para a criação de projetos especiais, personalizados e exclusivos.

O grés porcelânico técnico da Revigrés possui propriedades físicas adequadas a vários tipos de utilização: revestimento ou pavimento, em interiores e exteriores, em áreas públicas ou residenciais. Características como a inalterabilidade da cor, resistência ao impacto e resistência a manchas e a químicos dão resposta aos requisitos exigidos pelos projetos.

Flexible production grants Revigrés the unique capacity to develop specific, personalised and exclusive projects.

Revigrés full body porcelain tiles have physical properties adjusted to all types of use: wall or floor, indoor and outdoor, in public or residential areas. Characteristics such as colour inalterability, resistance to bending, impact resistance and resistance to stains and acids meet the projects' requirements.



A hipótese de misturar coleções, formatos e padrões da cerâmica permite uma grande variabilidade, não "castrando" o processo criativo. Esta versatilidade, em conjunto com a sua elevada resistência, são as razões pelas quais opto pelos revestimentos e pavimentos cerâmicos da Revigrés nos meus projetos.

Agrada-me a possibilidade técnica que os produtos da Revigrés apresentam e o facto de conseguir reproduzir o efeito estético de outras materialidades, garantindo um aspeto muitíssimo aproximado ao material original.

Além de uma marca de enorme referência nacional, com instalações de produção surpreendentemente modernas e tecnológicas, a Revigrés disponibiliza um serviço de apoio técnico ao projeto exemplar.

The possibility of mixing collections, formats, and patterns of ceramics permits great variability, and doesn't "castrate" the creative process. This versatility, plus their high strength, are the reasons why I go for Revigrés's ceramic wall and floor tiles in my designs.

I appreciate the technical possibility that Revigrés products offer and the fact that they can replicate the aesthetic effect of other materials, ensuring an appearance that is very close to the original material.

In addition to being a brand of enormous national significance, with surprisingly modern and hi-tech production facilities, Revigrés provides an excellent technical support service to projects.

Nuno Porfírio, Architect - Architect
A1V2 - Engenharia, Arquitetura & Urbanismo

HARRODS GALLERY

A Revigrés foi identificada, desde cedo, como um parceiro de confiança para um projeto tão prestigiante como o Harrods, em Londres. A coleção Cromática foi, sem dúvida, a melhor opção para esta obra emblemática.

Alan Collie
Diretor Comercial, Domus

HARRODS GALLERY

Revigrés was identified from the start as a reliable partner in such a prestigious project like Harrods in London. The Chromatic collection was certainly the best choice for this emblematic work.

Alan Collie
Commercial Director, Domus



Revigrés Online

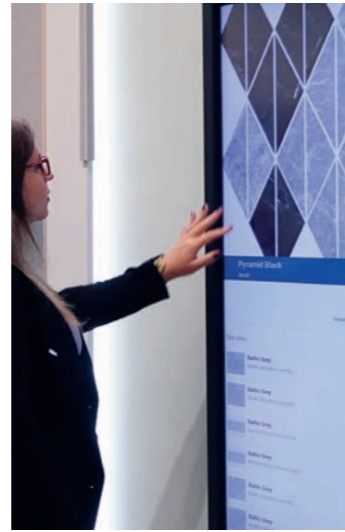

Construímos Relações

A Revigrés aposta na interatividade e imediatismo das plataformas digitais para manter um contacto permanente com os seus Clientes. Siga-nos em www.revigrés.com, através da nossa newsletter (com inscrição no site) e nas redes sociais.

APP REVIGRÉS AR

A App de Realidade Aumentada encontra-se disponível para Tablets e Smartphones, nos sistemas operativos iOS e Android. Experimente os produtos Revigrés em qualquer espaço da sua casa, em tempo real.

KIOSQUE DIGITAL

A Revigrés disponibiliza um quiosque digital nos seus pontos de venda que permite consultar todos os produtos da Marca, seleccionar e comparar os seus favoritos e escolher a solução que mais se adequa ao que procura, apenas com um toque.

SISTEMA 3D

Disponibilizamos um programa online, rápido e intuitivo, onde é possível criar o seu espaço personalizado: com base na planta, pode seleccionar os produtos Revigrés e visualizar o espaço a 3 dimensões, em diferentes perspetivas. No final, o programa fornece uma listagem das quantidades necessárias de cada produto.

We Build Relations

Revigrés turns to digital platform interactivity and immediacy to keep in touch with its Customers. Follow us on www.revigrés.com, by signing up to our newsletter on our website, and on the social networks.

REVIGRÉS AR APP

Augmented Reality App available for Tablets and Smartphones, iOS and Android operating systems. Try out Revigrés products in real time in any room in your house.

DIGITAL KIOSK

Revigrés provides digital kiosks at its points of sale where you can look up, select and compare all of the Brand's products at the touch of a button, to choose the solution that meets your needs.

3D SYSTEM

We provide a rapid, user-friendly online programme where you can create your personalised space: based on the plan, you can select Revigrés products and view the space in 3 dimensions from different perspectives. At the end the programme provides a list of the required quantities of each product.

Nous Construisons des Liens

Revigrés pari sur l'interactivité et l'imédiateté des plates-formes numériques en vue de maintenir un contact permanent avec ses Clients. Suivez-nous sur www.revigrés.com en vous abonnant à notre newsletter (après inscription sur le site) et sur les réseaux sociaux.

APP REVIGRÉS AR

Application de Réalité Augmentée disponible pour Tablettes et Smartphones dans les systèmes d'exploitation iOS et Android. Essayez les produits Revigrés dans toutes les pièces de votre maison, en temps réel.

KIOSQUE NUMÉRIQUE

Revigrés met à votre disposition un kiosque numérique dans ses points de vente qui permet de consulter tous les produits de la Marque, sélectionner et comparer vos favoris et choisir la solution qui s'adapte le mieux à ce que vous recherchez, avec une simple pression.

SYSTEME 3D

Nous proposons un programme en ligne, rapide et intuitif, où vous pouvez créer votre espace personnalisé: à partir du plan, vous pouvez sélectionner les produits Revigrés et visualiser l'espace en 3 dimensions, sous différentes perspectives. À la fin, le programme fournit une liste des quantités nécessaires de chaque produit.

Construimos Relaciones

Revigrés apuesta por la interactividad y la inmediatez de las plataformas digitales para mantener un contacto permanente con sus clientes. Síguenos en www.revigrés.com, a través de nuestro boletín de noticias (alta en el sitio web) y en las redes sociales.

APLICACIÓN REVIGRÉS AR

Aplicación de Realidad Aumentada disponible para tabletas y teléfonos inteligentes, y para los sistemas operativos iOS y Android. Pruebe los productos Revigrés en cualquier espacio de su casa en tiempo real.

KIOSCO DIGITAL

Revigrés dispone de un kiosco digital en sus puntos de venta que le permite consultar todos los productos de la marca, seleccionar y comparar sus favoritos, y elegir la solución que más se adapta a lo que busca, solo con un toque.

SISTEMA 3D

Ponemos a su disposición un programa online, rápido e intuitivo, donde puede crear su espacio personalizado: en base a la planta, puede seleccionar los productos Revigrés y visualizar el espacio en 3 dimensiones, con diferentes perspectivas. Al final, el programa ofrece un listado de las cantidades necesarias de cada producto.

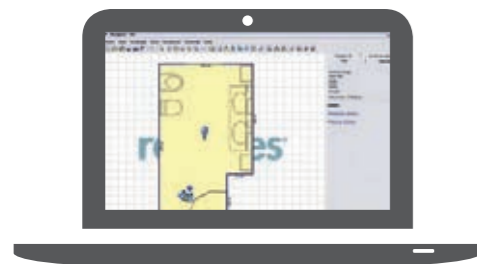
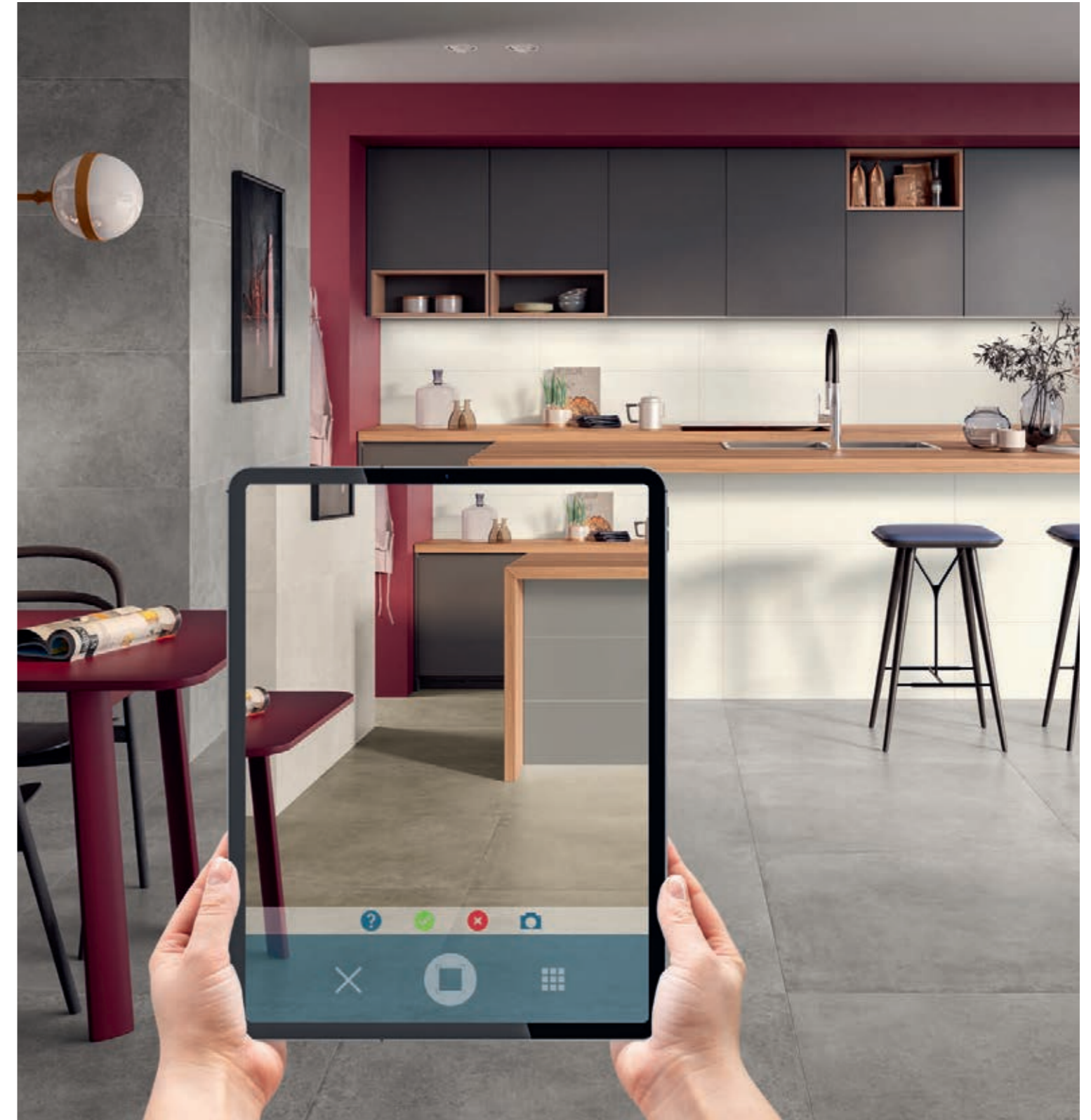

Planta do espaço _ House plan
Plan de l'espace _ Planta del espacio



Ambiente 3D _ 3D environments
Environnement 3D _ Ambiente 3D



Relatório de quantidades _ Quantity maps
Rapport des quantités _ Informe de cantidades



Ecotiles

A nossa cerâmica é verde

Na natureza, nada se perde, tudo se transforma.

Reduzir o impacto ambiental das nossas escolhas, no planeta - e, consequentemente, melhorar a nossa Pegada Ecológica - sem abdicar do conforto e saúde, do design e da qualidade é uma tendência que ganha força todos os dias.

Na Revigrés, assumimos como nossas estas preocupações, integrando-as nos nossos valores institucionais e materializando-as numa Política Ambiental estruturada, apoiada no investimento em inovação e na adoção de um comportamento eco-eficiente, nomeadamente:

- A valorização de 98% dos resíduos do processo, incorporados diretamente na produção e outros processos fabris;
- O privilegiar a valorização em detrimento da deposição;
- A opção pelo ECODESIGN: um plano e processo produtivo mais eficiente que permite uma redução nos impactos ambientais;
- A reutilização da totalidade das águas residuais industriais;
- A gestão das emissões de CO2 e implementação de medidas para a sua redução;
- A utilização de matérias-primas inertes e consequente redução de resíduos perigosos;
- A implementação de um plano de racionalização energética dos processos e equipamentos;
- A utilização de embalagens recicladas na sua totalidade e paletes tratadas;
- A produção de energia elétrica através de painéis fotovoltaicos com vista à utilização de energia limpa.

A Revigrés é certificada na Gestão Ambiental, o que inclui a sistematização e controlo dos processos, em conformidade com o referencial normativo NP EN ISO 14001:2015.

Our tiles are green

In nature, nothing is lost, everything is transformed.

Being able to reduce the environmental impact of our choices on the planet - and subsequently improving our carbon footprint - without giving up the comfort and health, design and quality, is a trend gaining strength every day.

Here at Revigrés we assume these concerns as our own, incorporating them into our institutional values and transforming them into a structured Environmental Policy, backed by investment in innovation and the adoption of eco-efficient behaviour, namely:

- Recovering 98% of all waste that results from the process and using it in production and other manufacturing processes;
- Prioritising recovery over disposal always;
- Choosing ECODESIGN: a more efficient production plan and process that reduces the environmental impact;
- Reusing all industrial wastewater;
- Managing CO2 emissions and implementing reduction measures;
- Using inert matter and subsequently reducing hazardous waste;
- Implementing an energy efficiency plan for procedures and equipment;
- Using fully recycled packaging and processed pallets;
- Power produced by photovoltaic cells for the use of clean energy.

Revigrés has Certification in Environmental Management, which includes process systematisation and monitoring, in accordance with the reference standard NP EN ISO 14001:2015.

Notre céramique est verte

Dans la nature, rien ne se perd, tout se transforme.

Réduire l'impact environnemental de nos choix sur la planète, et, par conséquent, améliorer notre empreinte écologique sans renoncer au confort et à la santé, au design et à la qualité est une tendance qui s'impose de jour en jour.

Chez Revigrés, nous assumons comme nôtres ces préoccupations, en les intégrant dans nos valeurs institutionnelles et en les matérialisant dans une Politique Environnementale structurée, soutenue par des investissements dans l'innovation et l'adoption de comportements éco-efficaces, à savoir :

- La valorisation de 98% des déchets du processus et leur incorporation dans la production et d'autres procédés de fabrication;
- Privilégier la valorisation au détriment du dépôt;
- Le choix de l'ECODESIGN: un plan et un processus de production plus efficace qui permet une réduction de l'impact sur l'environnement ;
- La réutilisation de la totalité des eaux usées industrielles ;
- La gestion des émissions de CO2 et la mise en œuvre de mesures pour les réduire ;
- L'utilisation de matériaux inertes et, donc, une réduction des déchets dangereux ;
- La mise en œuvre d'un plan de rationalisation énergétique des procédés et des équipements ;
- L'utilisation d'emballages recyclés dans leur intégralité et de palettes transformées ;
- La production d'électricité par des panneaux photovoltaïques en vue d'une utilisation d'énergie propre.

Revigrés est certifiée en Management de l'Environnement, ce qui comprend la systématisation et le contrôle des procédés, conformément au référentiel normatif NP EN ISO 14001: 2015.

Nuestra cerámica es verde

En la naturaleza, nada se pierde, todo se transforma.

Reducir el impacto medioambiental de nuestras elecciones en el planeta —y, por tanto, mejorar nuestra huella ecológica—, sin renunciar al confort y a la salud, al diseño y a la calidad, es una tendencia que cobra fuerza cada día.

En Revigrés, asumimos como propias estas preocupaciones, las integramos en nuestros valores institucionales y las materializamos en una política medioambiental estructurada, apoyada en la inversión en innovación y en la adopción de un comportamiento ecoeficiente, en particular:

- La valorización del 98 % de los residuos del producción y a otros procesos fabriles;
- La primacía de la valorización sobre la deposición;
- La elección del ECODESIGN: un plan y un proceso productivo más eficientes que permiten reducir el impacto medioambiental;
- La reutilización de todas las aguas residuales industriales;
- La gestión de las emisiones de CO2 y la implementación de medidas para su reducción;
- La utilización de materias primas inertes y la consecuente reducción de residuos peligrosos;
- La implementación de un plan de racionalización energética de los procesos y equipamientos;
- La utilización de embalajes reciclados en su totalidad y palets tratados;
- La producción de energía eléctrica utilizando paneles fotovoltaicos con vistas a utilizar una energía limpia.

Revigrés está certificada en gestión medioambiental, que incluye la sistematización y el control de procesos, de conformidad con la norma de referencia NP EN ISO 14001:2015.



DECLARAÇÕES AMBIENTAIS DE PRODUTO (EPD's) COMPATÍVEIS COM OS SISTEMAS DE CERTIFICAÇÃO BREEAM E LEED

A sustentabilidade da construção assenta, cada vez mais, na utilização de materiais ecoeficientes.

As coleções de produtos Porcelanato, Revigrés Tech e Ecotiles são certificadas com Declarações Ambientais de Produto (EPD's), segundo a Norma ISO 14025 (tipo III), compatíveis com os Sistemas de Certificação da Construção Sustentável BREEAM e LEED, que quantificam o seu impacto ambiental. Para o efeito, foram sujeitas a um processo de análise do Ciclo de Vida (pré-produção, produção, e pós-produção) e devidamente validadas por uma entidade independente e internacional: o sistema IBU da organização alemã The Institut Bauen und Umwelt e.V.

Os produtos destas coleções são um contributo significativo para a obtenção das certificações ambientais de edifícios e, consequentemente, para a sustentabilidade da construção.

EPD's E AS CERTIFICAÇÕES LEED E BREEAM

Destacamos os contributos das EPD's para duas das certificações de construção sustentável:



• LEED (U.S. Green Building Council) - fornecem informação para duas categorias: Materiais e Recursos e Qualidade do Ambiente Interior.

• BREEAM (Building Research Establishment Environmental Assessment Method) - fornecem informação para duas categorias: Saúde e Bem-estar (qualidade do ar) e Materiais (impacto no ciclo de vida, durabilidade, responsabilidade das matérias primas e desempenho/eficiência).

ENVIRONMENTAL PRODUCT DECLARATIONS (EPDs) COMPATIBLE WITH THE BREEAM AND LEED CERTIFICATION SYSTEMS

Building sustainability is increasingly based on the use of eco-efficient materials.

The Ecotiles, Revigrés Tech and Porcelanato product collections are certified by Environmental Product Declarations (EPDs), pursuant to standards ISO 14025 (type III), compatible with BREEAM and LEED Sustainable Construction Certification Systems that quantify their environmental impact. For this purpose, they have been submitted to a Life Cycle Assessment (LCA) process (pre-production, production and post production) and were certified by an independent and international entity: the IBU system of the German organisation Institut Bauen und Umwelt e.V.

These product collections help buildings obtain environmental and sustainability building certification.

EPDs AND LEED AND BREEAM CERTIFICATIONS

The following are EPDs contributions to two sustainable building certifications:



• LEED (U.S. Green Building Council) - provide information for two categories: Materials and Resources and Quality of the Indoor Environment.

• BREEAM (Building Research Establishment Environmental Assessment Method) - provide information for two categories: Health and Well-being (air quality) and Materials (life cycle impact, durability, the responsibility of raw materials and performance/efficiency).

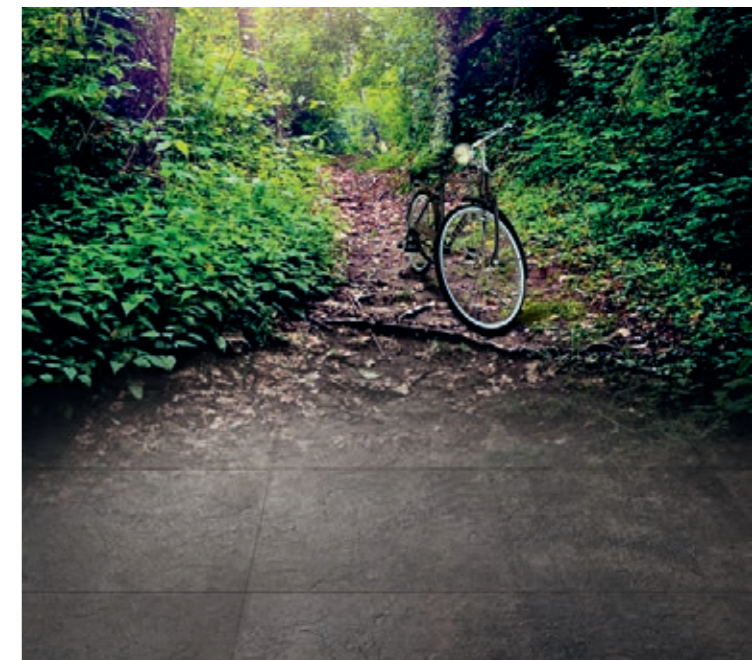

DÉCLARATIONS ENVIRONNEMENTALES PRODUIT (DEPs) COMPATIBLES AVEC LES SYSTÈMES DE CERTIFICATION BREEAM ET LEED

La durabilité de la construction repose, de plus en plus, sur l'utilisation de matériaux éco-efficaces.

Les collections de produits Porcelanato, Revigrés Tech et Ecotiles sont certifiées à travers des Déclarations Environnementales Produit (DEPs), selon la Norme ISO 14025 (type III), compatibles avec les Systèmes de Certification de Construction Durable BREEAM et LEED, qui quantifient leur impact environnemental. A cet effet, elles ont été soumises à un processus d'analyse du Cycle de Vie (préproduction, production et post-production) et dûment validées par une entité indépendante et internationale: le système IBU de l'organisation allemande The Institut Bauen und Umwelt e.V.

Les produits de ces collections sont une contribution significative pour l'obtention des certifications environnementales des édifices et, par conséquent, pour la durabilité de la construction.

DEPs ET LES CERTIFICATIONS LEED ET BREEAM

Nous mettons en exergue les contributions des DEPs pour deux des certifications de construction durable:



• LEED (U.S. Green Building Council) – fournissent l'information pour deux catégories : Matériaux et Ressources et Qualité de l'Environnement Intérieur.

• BREEAM (Building Research Establishment Environmental Assessment Method) – fournissent l'information pour deux catégories : Santé et Bien-être (qualité de l'air) et Matériaux (impact dans le cycle de vie, durabilité, responsabilité des matières premières et performance/efficacité).

DECLARACIONES AMBIENTALES DE PRODUCTO (DAPs) COMPATIBLES CON LOS SISTEMAS DE CERTIFICACIÓN BREEAM Y LEED

La sostenibilidad de la construcción se basa, cada vez más, en la utilización de materiales ecoeficientes.

Las colecciones de productos Porcelanato, Revigrés Tech y Ecotiles están certificadas con Declaraciones Ambientales de Producto (DAPs), según la norma ISO 14025 (tipo III), compatibles con los sistemas de certificación de construcción sostenible BREEAM y LEED, que cuantifican su impacto medioambiental. Para tal efecto, se han sometido a un proceso de análisis del ciclo de vida (preproducción, producción y posproducción) y han sido debidamente validadas por una entidad independiente e internacional: el sistema IBU de la organización alemana The Institut Bauen und Umwelt e.V.

Los productos de estas colecciones contribuyen significativamente a la obtención de los certificados ambientales de edificios y, por consiguiente, a la sostenibilidad de la construcción.

DAPs Y LOS CERTIFICADOS LEED Y BREEAM

Destacamos la contribución de las DAPs a los dos certificados de construcción sostenible:



• LEED (U.S. Green Building Council): proporcionan información sobre dos categorías: materiales y recursos, y calidad del ambiente interior.

• BREEAM (Building Research Establishment Environmental Assessment Method): proporcionan información sobre dos categorías: salud y bienestar (calidad del aire) y materiales (impacto en el ciclo de vida, durabilidad, responsabilidad de las materias primas y rendimiento/eficacia).

Revigrés Products

Tipologia

Typology _ Tipologie _ Tipologia



Grés Porcelânico Técnico
Full-Body Porcelain
Grès Cérame Pleine Masse
Gres Porcelânico Técnico

Soluções de cerâmica para revestimentos e pavimentos, interiores e exteriores, espaços públicos e residenciais, com características técnicas e estéticas uniformes em toda a espessura da peça, conferindo-lhes elevada resistência.

Ceramic wall and floor tiles, for indoor and outdoor use in residential and public spaces, with uniform technical and aesthetic characteristics throughout, ensuring high resistance.

Solutions en céramique pour revêtements muraux et de sols, intérieurs et extérieurs, espaces publics et résidentiels, avec des caractéristiques techniques et esthétiques uniformes sur toute l'épaisseur du carreau, ce qui leur confère une grande résistance.

Soluciones de cerámica para revestimientos y pavimentos, interiores y exteriores, espacios públicos y residenciales, con características técnicas y estéticas uniformes en todo el grosor de la pieza, aportándoles una elevada resistencia.



Grés Porcelânico Esmaltado
Glazed Porcelain
Grès Cérame Emailé
Gres Porcelânico Esmaltado

Soluções de cerâmica para revestimentos e pavimentos, interiores e exteriores, espaços públicos e residenciais, que combinam as características técnicas do grés porcelânico com diversos efeitos estéticos.

Ceramic wall and floor tiles, for indoor and outdoor use in residential and public spaces, that combine the technical characteristics of porcelain with a variety of aesthetic effects.

Des solutions en céramique pour revêtements muraux et de sols, intérieurs et extérieurs, espaces publics et résidentiels, alliant les caractéristiques techniques du grés cérame à divers effets esthétiques.

Soluciones de cerámica para revestimientos y pavimentos, interiores y exteriores, espacios públicos y residenciales, que combinan las características técnicas del gres porcelánico con diversos efectos estéticos.



Revestimentos Cerâmicos Vidrados
Glazed Ceramic Wall Tiles
Faïence Pâte Blanche
Revestimientos Cerâmicos Vidriados

Soluções de cerâmica para revestimentos interiores com uma vasta gama de cores, diversos formatos e superfície em mate, brilho ou estruturada.

Indoor ceramic wall tiles with a broad colour range, a variety of formats and surfaces with matt, gloss and structured finish.

Solutions en céramique pour revêtements muraux intérieurs avec une large gamme de couleurs, plusieurs formats et une surface mate, brillante ou structurée.

Soluciones de cerámica para revestimientos interiores con una amplia gama de colores, diversos formatos y superficie mate, brillante o estructurada.

A multiplicidade de efeitos estéticos da cerâmica da Revigrés – madeira, pedra, cimento, mármore, metálico, entre outros – permite infindáveis combinações para a criação de ambientes modernos e atuais, em linha com as últimas tendências na arquitetura e no design de interiores. Com todas as vantagens da cerâmica: inalterabilidade das características, elevada durabilidade e fácil limpeza e manutenção.

The multiple aesthetic effects of Revigrés ceramic tiles – wood, stone, cement, marble, metal, etc. – can be combined in an infinite number of ways to create modern and fashionable environments, in line with the latest trends of architecture and interior design. With all of the advantages of ceramics: its unalterable features, high durability and easy cleaning and maintenance.

La multitude d'effets esthétiques du cérame de Revigrés – bois, pierre, ciment, marbre, métal, parmi d'autres – permet une kyrielle de combinaisons pour créer des atmosphères modernes et actuelles, en suivant les dernières tendances de l'architecture et du design d'intérieurs. Avec tous les avantages du cérame : l'inaltérabilité des caractéristiques, une grande durabilité et un nettoyage et un entretien faciles.

Los múltiples efectos estéticos del cerámica de Revigrés – madera, piedra, cemento, mármol, metálico, etc. – permiten una infinidad de combinaciones para la creación de ambientes modernos y actuales, en línea con las últimas tendencias de la arquitectura y del diseño de interiores. Con todas las ventajas de la cerámica: inalterabilidad de las características, gran durabilidad y fácil limpieza y mantenimiento.



Vantagens _ Advantages _ **Avantages** _ Ventajas:



RESISTÊNCIA ÀS MANCHAS E A QUÍMICOS
RESISTANCE TO STAINING AND CHEMICALS
RÉSISTANCE AUX TACHES ET AUX SUBSTANCES CHIMIQUES
RESISTENCIA A LAS MANCHAS Y A LOS PRODUCTOS QUÍMICOS



RESISTÊNCIA AO DESGASTE / ABRASÃO
RESISTANCE TO WEAR / ABRASION
RÉSISTANCE À L'USURE ET À L'ABRASION
RESISTENCIA AL DESGASTE / ABRASIÓN



ECO SUSTENTÁVEL: NÃO LIBERTA SUBSTÂNCIAS TÓXICAS (RADÃO, COV)
ECO-SUSTAINABLE: IT DOES NOT RELEASE TOXIC SUBSTANCES (RADON, VOC)
ECO DURABLE : NE LIBÈRE PAS DE SUBSTANCES TOXIQUES (RADON, COV)
RESPECTO POR EL MEDIO AMBIENTE: SIN LIBERACIÓN DE SUSTANCIAS TÓXICAS (RADÓN, COV)



RESISTÊNCIA MECÂNICA
MECHANICAL RESISTANCE
RÉSISTANCE MÉCANIQUE
RESISTENCIA MECÁNICA



BOM ISOLAMENTO ELÉTRICO
GOOD ELECTRICAL INSULATION
BONNE ISOLATION ÉLECTRIQUE
BUEN AISLAMIENTO ELÉCTRICO



RESISTÊNCIA AO FOGO
RESISTANCE TO FIRE
RÉSISTANCE AU FEU
RESISTENCIA AL FUEGO



FÁCIL LIMPEZA E MANUTENÇÃO
EASY CLEANING AND MAINTENANCE
NETTOYAGE ET ENTRETIEN FACILE
FÁCIL LIMPIEZA Y MANTENIMIENTO

Legenda de produto _ Product Key _ **Légende du produit** _ Leyenda del producto:

NOME DO PRODUTO PRODUCT NAME NOM DU PRODUIT NOMBRE DEL PRODUCTO		PREÇO (GRUPO P) PRICE (GROUP P) PRIX (GROUPE P) PRECIO (GRUPO P)		VARIACÃO DE TONALIDADE COLOUR VARIATION VARIATIONS DE TONALITÉ VARIACIONES DE TONALIDAD (V1, V2, V3, V4)		RESISTÊNCIA AO ESCORREGAMENTO ANTISLIP RESISTANCE RÉSISTANCE À LA GLISSANCE RESISTENCIA ANTIDESLIZAMIENTO (BS 7976-2 (PTV))		RESISTÊNCIA AO ESCORREGAMENTO ANTISLIP RESISTANCE RÉSISTANCE À LA GLISSANCE RESISTENCIA ANTIDESLIZAMIENTO (ANSI A137.1 - DCOF)		
CROMÁTICA CITRUS										
10x10	SOFT	[9,6x9,6x0,85 cm]	P143	V1	5	—	—	—	—	U4P4E3C2
	MATT RECT	[29,6x29,6x0,85 cm]	P123	V1	5	class 2	A	R10	36* ≥0,42	U4P4E3C2
30x30	SOFT	[29,6x29,6x0,85 cm]	P123	V1	5	—	—	—	—	U4P4E3C2
	POL	[29,6x29,6x0,80 cm]	P137	V1	3	—	—	—	—	U3P3E3C2
30x60	MATT RECT	[29,6x59,2x0,85 cm]	P123	V1	5	class 2	A	R10	36* ≥0,42	U4P3E3C2
	SOFT	[29,6x59,2x0,85 cm]	P123	V1	5	—	—	—	—	U4P3E3C2
60x60	POL	[29,6x59,2x0,80 cm]	P137	V1	3	—	—	—	—	U3P3E3C2
	MATT RECT	[59,2x59,2x0,85 cm]	P123	V1	5	class 2	A	R10	36* ≥0,42	U4P4E3C2
60x60	SOFT	[59,2x59,2x0,85 cm]	P123	V1	5	—	—	—	—	U4P4E3C2
	POL	[59,2x59,2x0,80 cm]	P137	V1	3	—	—	—	—	U3P3E3C2
FORMATO FORMAT FORMAT FORMATO		CALIBRE e ESPESSURA CALIBRE and THICKNESS CALIBRE et ÉPAISSEUR CALIBRE y ESPESOR		RESISTÊNCIA AO ESCORREGAMENTO ANTISLIP RESISTANCE RÉSISTANCE À LA GLISSANCE RESISTENCIA ANTIDESLIZAMIENTO (DIN 51130)		RESISTÊNCIA AO ESCORREGAMENTO ANTISLIP RESISTANCE RÉSISTANCE À LA GLISSANCE RESISTENCIA ANTIDESLIZAMIENTO (DIN 51097)		RESISTÊNCIA AO ESCORREGAMENTO (MÉTODO DO PÊNDULO) ANTISLIP RESISTANCE (PENDULUM METHOD) RÉSISTANCE À LA GLISSANCE (MÉTHODE DU PENDULE) RESISTENCIA ANTIDESLIZAMIENTO (MÉTODO DEL PÊNDULO) (ENV 12633)		
ACABAMENTO FINISH FINITION ACABADO		TIPOS DE APLICAÇÃO TYPES OF USE TYPES D'APPLICATION TIPOS DE APLICACIÓN		TIPOS DE APLICAÇÃO TYPES OF USE TYPES D'APPLICATION TIPOS DE APLICACIÓN (1, 2, 3, 4, 5)		PAG 398				

Revigrés Tech

Eco inovação para um futuro sustentável

A REVIGRÉS aposta no desenvolvimento de projetos criativos e multifuncionais que conjugam funções técnicas e estéticas.

Eco-innovation for a sustainable future

REVIGRÉS is committed to the development of creative and multifunctional projects which combine aesthetic and technical functions.



Eco-innovation pour un futur durable

REVIGRÉS parie sur le développement de projets créatifs et multifonctionnels, qui conjuguent les fonctions esthétiques et techniques.

Ecoinnovación para un futuro sostenible

REVIGRÉS apuesta por la ejecución de proyectos creativos y multifuncionales que combinan funciones estéticas y técnicas.

Revicomfort pag. 364

Pavimento em grés porcelânico amovível e reutilizável.
Removable and reusable full body porcelain floor tiles.
Sol en grés cérame portable et reutilisable.
Pavimento en grés porcelânico portátil y reutilizable.



Revicare pag. 370

Revestimento e pavimento antibacteriano.
Antibacterial wall and floor tile.
Muraux et revêtements de sol antibactérien.
Revestimiento y pavimento antibacteriano.



Táteis _ Tactile pag. 052

Design inclusivo.
Inclusive design.
Design inclusif.
Diseño inclusivo.



Revisilent pag. 366

Pavimento com isolamento acústico. Cerâmica & cortiça.
Soundproof floor tile. Ceramics & cork.
Revêtement de sol avec isolation acoustique. Céramique & liège.
Pavimento con aislamiento acústico. Cerámica y corcho.

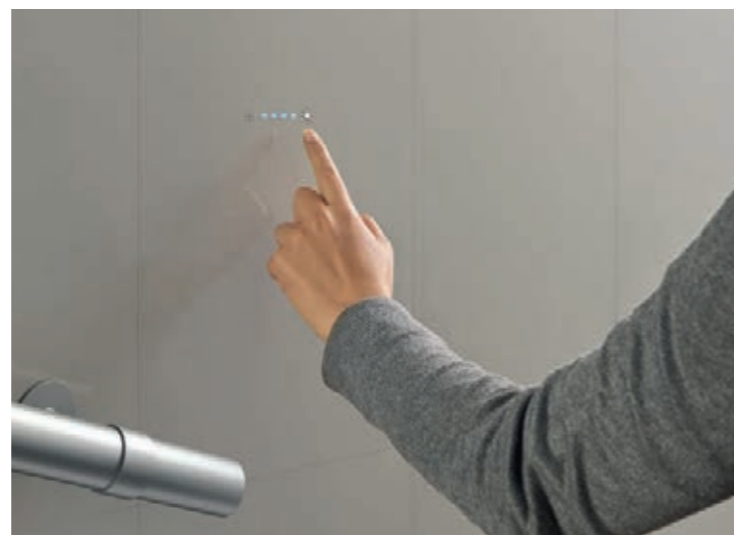

Revisense pag. 368

Cerâmica sensítiva: sem botões, sem teclas
Sensitive ceramics: no buttons, no keys
Céramique sensitive: pas de boutons, pas de touches
Cerámica sensible: sin botones, sin teclas



Deck Smart pag. 372

Deck cerâmico em pavimento sobrelevado.
Ceramic deck on raised floor.
Deck céramique en plancher surélevé.
Deck cerâmico en suelos elevados.



Fachadas ventiladas _ Ventilated façades pag. 374

Solução para maior eficiência energética dos edifícios
Solution for improved building's energy efficiency
Solution pour une amélioration de l'efficacité énergétique des bâtiments
Solución para una mayor eficiencia energética de los edificios

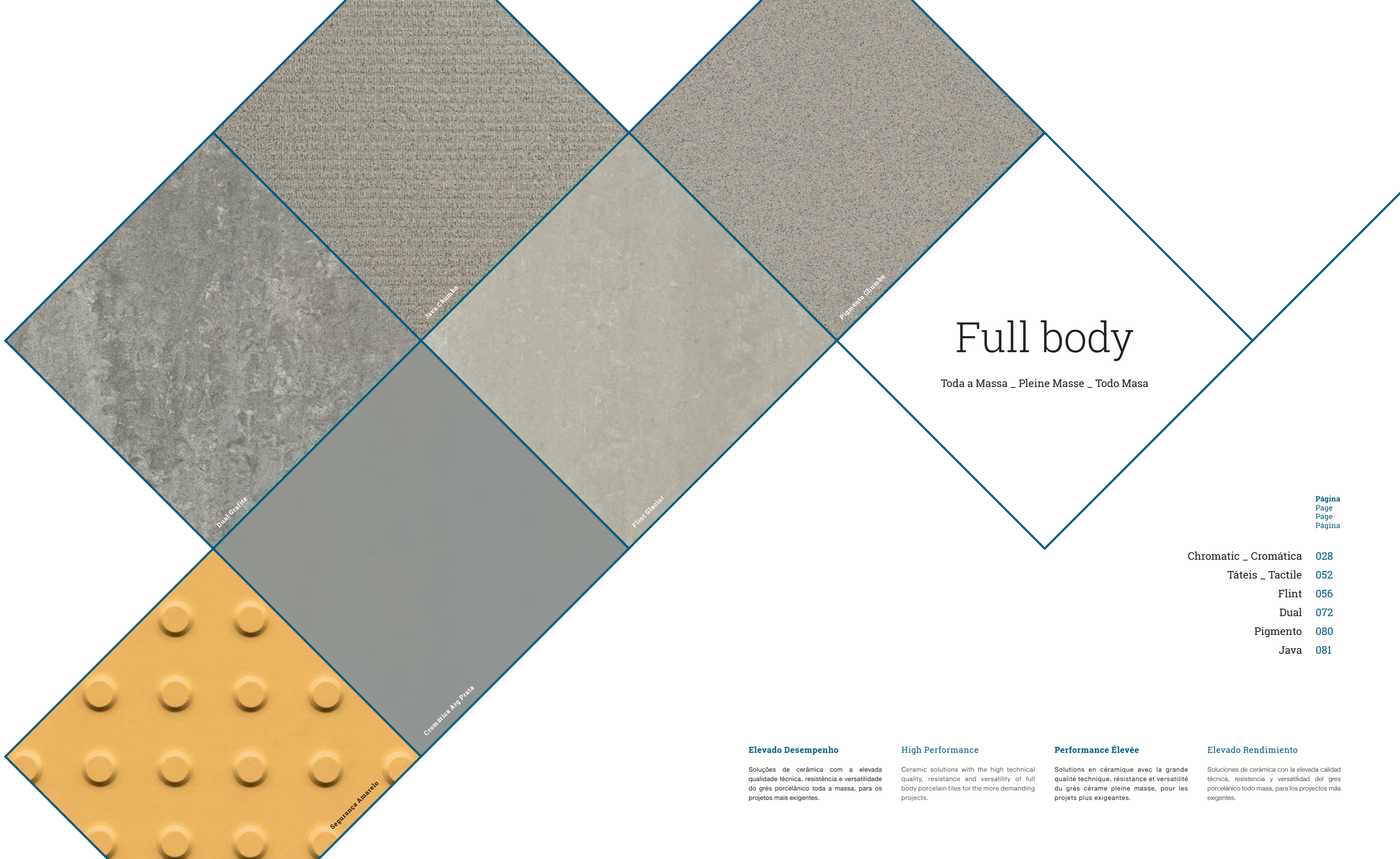

Java Chuambo

Pigmento Chuambo

Dual Grafite

Flint Glaciar

Cromática Arg Prata

Segurança Amarelo

Full body

Toda a Massa _ Pleine Masse _ Todo Masa

Página
Page
Page
Página

Chromatic _ Cromática	028
Táteis _ Tactile	052
Flint	056
Dual	072
Pigmento	080
Java	081

Elevado Desempenho

Soluções de cerâmica com a elevada qualidade técnica, resistência e versatilidade do grés porcelânico toda a massa, para os projetos mais exigentes.

High Performance

Ceramic solutions with the high technical quality, resistance and versatility of full body porcelain tiles for the more demanding projects.

Performance Élevée

Solutions en céramique avec la grande qualité technique, résistance et versatilité du grès cérame pleine masse, pour les projets plus exigeantes.

Elevado Rendimiento

Soluciones de cerámica con la elevada calidad técnica, resistencia y versatilidad del grés porcelánico todo masa, para los proyectos más exigentes.

Uma coleção com elevada qualidade técnica que permite criar novos padrões para ambientes personalizados.
A high technical quality collection that allows you to design new patterns for customised environments.
Une collection avec une grande qualité technique qui permet de créer de nouveaux motifs pour des ambiances personnalisées.
Una colección con gran calidad técnica que permite crear nuevos estándares para ambientes personalizados.

Cromática _ Chromatic

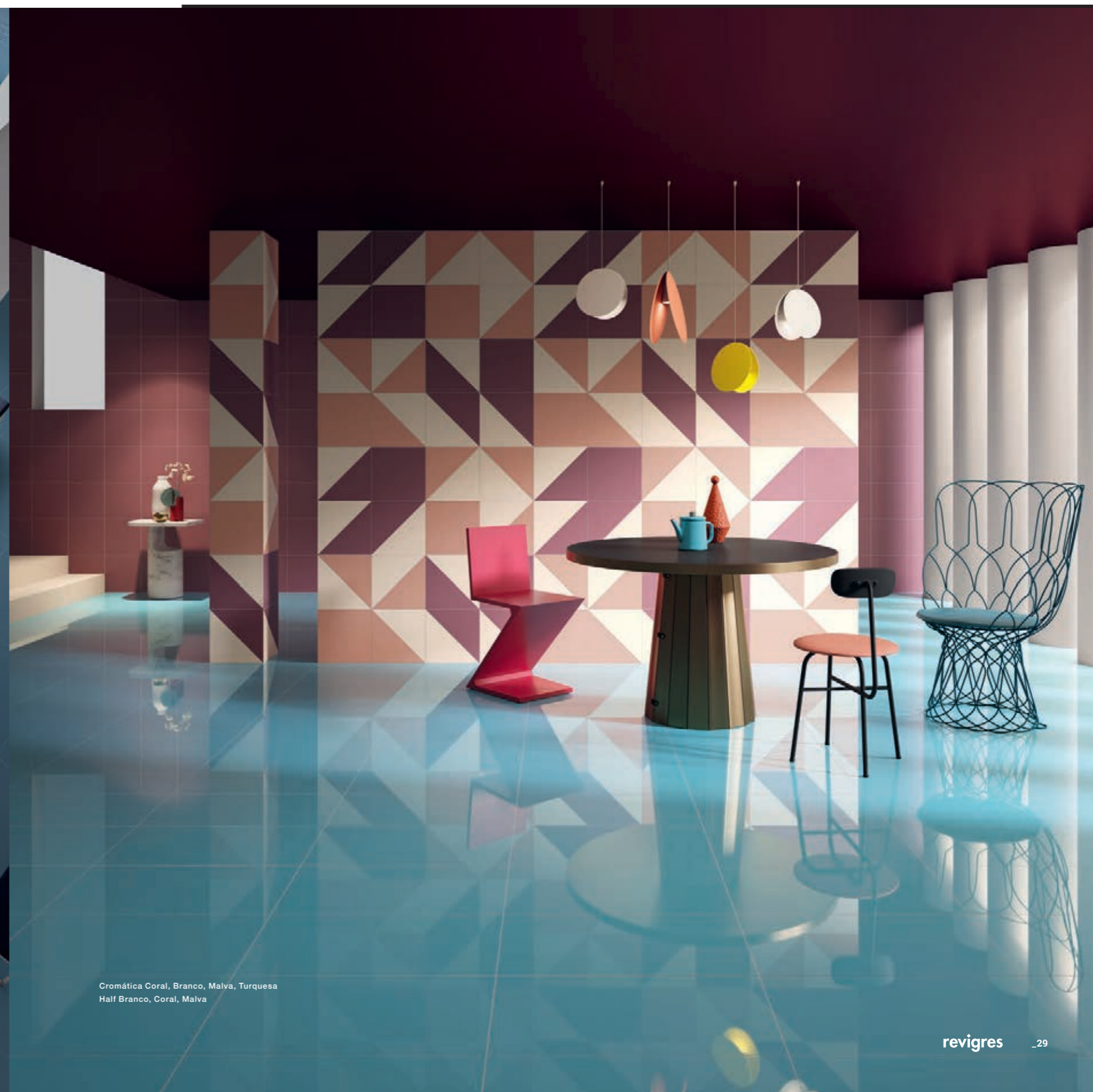

Cromática Coral, Branco, Malva, Turquesa
Half Branco, Coral, Malva

Cromática _ Chromatic Remix & Cuts

40 cores
colors
couleurs
colores

10 formatos
formats
formats
formatos

03 acabamentos
finishes
finitions
acabados

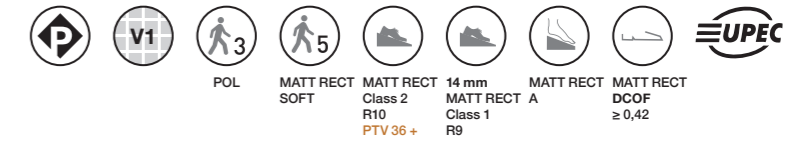

30x30 (12"x12")
[29,6x29,6 cm]

MATT NAT ± 0,77 cm
MATT RECT ± 0,85 cm
SOFT ± 0,85 cm
POL ± 0,80 cm



30x60 (12"x24")
[29,6x59,2 cm]

MATT RECT ± 0,85 cm
SOFT ± 0,85 cm
POL ± 0,80 cm



60x60 (24"x24")
[59,2x59,2 cm]

MATT RECT ± 0,85 cm
MATT RECT ± 1,40 cm
SOFT ± 0,85 cm
POL ± 0,80 cm

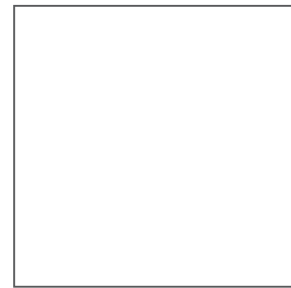

90x90 (35"x35")
[89,0x89,0 cm]

MATT RECT ± 1,05 cm
SOFT ± 1,05 cm
POL ± 0,98 cm



60x120 (24"x47")
[59,2x118,4 cm]

MATT RECT ± 0,98 cm
SOFT ± 0,98 cm
POL ± 0,93 cm

Cube



(*) 10x10 (4"x4")
[9,6x9,6 cm]

SOFT ± 0,85 cm

Chevron

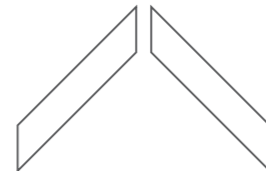

(*) 10x60 (4"x24")
[9,6x59,2 cm]

SOFT ± 0,85 cm



(*) 10x30 (4"x12")
[9,6x29,6 cm]

SOFT ± 0,85 cm

Half

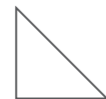

(*) 30x30x42 (12"x12"x16")
[29,6x29,6x41,7 cm]

SOFT ± 0,85 cm

Trio



20x22 (8"x9")

SOFT ± 0,85 cm

60x120	90x90	MATT NAT	MATT RECT ± 1,40 cm	MATT RECT PVT 36+	CHEVRON (€/m²)	HALF (€/m²)	TRIO (€/peça - piece)
Grafite Preto Superbranco	Antracite Ice Iron Platina Preto Quartz Superbranco	Branco Ice Platina Preto Superbranco	Arg Prata Astral Branco Grafite Preto Superbranco	Alloy Anis Arg Prata Bege Bone Branco Brick Café Citrus Clorofila Cobalto Coral Duna	Grafite Ice Iron Jade Lava Luna Ocre Oliva Opala Pistachio Platina Quartz Superbranco Titanium Turquesa	Antracite Branco Grafite Ice Jet Platina Preto Quartz Superbranco	Alloy Arg Prata Branco Grafite Malva Ocre Oliva Teal
							Aurora (Grafite + Titanium + Malva) Cosy Autumn (Lava + Branco + Luna) Deep Ocean (Teal + Bone + Jade) Moonlight (Antracite + Grafite + Alloy) Spring Spirit (Citrus + Branco + Oliva) Starry Sky (Antracite + Lava + Opala) Sunset Breeze (Ocre + Malva + Coral) Winter Fall (Grafite + Luna + Titanium)

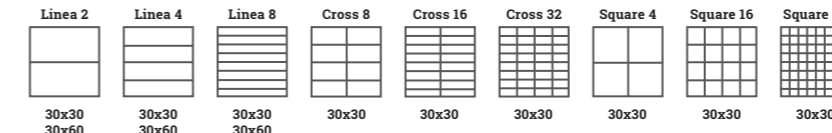

Pág. 50

		Peças / Pieces	Espeçura (mm) Thickness (mm)	Caixa / Box		Europaleta / Europallet			
		Nº Peças No Pieces		M² Aprox. No of Sq. M. Approx.	Peso (Kg) Weight Kg	Nº Caixas No Boxes	M² Aprox. No of Sq. M. Approx.	Peso (Kg) Weight (Kg)	
10x10 cm	Soft	CUBE (*)	± 8,5 ±5%	32	0,32	5,8	180	57,60	1 065
10x30 cm	Soft	CHEVRON (*)	± 8,5 ±5%	36	0,69	15,4	36	24,84	575
10x60 cm	Soft	CHEVRON (*)	± 8,5 ±5%	15	0,71	14,2	50	35,50	731
20x22 cm	Soft	TRIO	± 8,5 ±5%	10	-	10,0	36	-	381
30x30x42 cm	Soft	HALF (*)	± 8,5 ±5%	22	1,00	19,1	36	36,00	708
30x30 cm	Matt Nat / Nat	CROMÁTICA	± 7,7 ±5%	10	0,90	17,5	64	57,60	1 141
	Matt Rect / Soft	CROMÁTICA	± 8,5 ±5%	10	0,90	18,0	64	57,60	1 173
	Matt Rect / Soft	CROMÁTICA ICE	± 9,0 ±5%	10	0,90	21,0	64	57,60	1 365
	Matt Rect / Soft	CROSS, LINEA, SQUARE	± 8,5 ±5%	11	1,00	16,5	45	45,00	763
	Pol	CROMÁTICA	± 8,0 ±5%	10	0,90	16,0	64	57,60	1 045
30x60 cm	Pol	CROMÁTICA ICE	± 8,5 ±5%	10	0,90	18,8	64	57,60	1 224
	Pol	CROSS, LINEA, SQUARE	± 8,0 ±5%	11	1,00	16,0	45	45,00	741
	Matt Rect / Soft	CROMÁTICA	± 8,5 ±5%	5	0,90	18,0	60	54,00	1 101
	Matt Rect / Soft	CROMÁTICA ICE	± 9,0 ±5%	5	0,90	21,0	60	54,00	1 281
	Matt Rect / Soft	LINEA	± 8,5 ±5%	7	1,25	26,5	24	30,00	657
60x60 cm	Pol	CROMÁTICA	± 8,0 ±5%	5	0,90	16,0	60	54,00	981
	Pol	CROMÁTICA ICE	± 8,5 ±5%	5	0,90	18,8	60	54,00	1 149
	Pol	LINEA	± 8,0 ±5%	7	1,25	26,5	24	30,00	657
	Matt Rect / Soft	CROMÁTICA	± 8,5 ±5%	4	1,44	28,7	36	51,84	1 053
60x120 cm	Matt Rect / Soft	CROMÁTICA ICE	± 9,0 ±5%	4	1,44	33,5	36	51,84	1 227
	Matt Rect	CROMÁTICA 14 mm	± 14,0 ±0,5 mm	3	1,08	34,2	32	34,56	1 117
	Pol	CROMÁTICA	± 8,0 ±5%	4	1,44	26,7	36	51,84	981
	Pol	CROMÁTICA ICE	± 8,5 ±5%	4	1,44	30,0	36	51,84	1 101
87x87 cm	Matt Rect / Soft	CROMÁTICA	± 9,8 ±5%	2	1,44	33,0	30	43,20	1 011
	Pol	CROMÁTICA ICE	± 9,3 ±5%	2	1,44	30,0	30	43,20	951
90x90 cm	Matt Rect / Soft	CROMÁTICA ICE	± 10,5 ±0,5 mm	2	1,50	39,0	24	36,00	959
	Pol	CROMÁTICA ICE	± 9,8 ±5%	2	1,50	37,0	24	36,00	911
90x90 cm	Matt Rect / Soft	CROMÁTICA	± 10,5 ±0,5 mm	2	1,62	39,0	24	38,88	991
	Pol	CROMÁTICA	± 9,8 ±5%	2	1,62	37,0	24	38,88	943

De modo a proteger a superfície das peças, os produtos no acabamento polido têm uma fina camada de impermeabilizante, que apenas deve ser removida após a conclusão da obra.
Tiles with polished finish are protected with waterproof coating that must be removed only after the works are concluded.

En vue de protéger la surface des pièces, les produits à la finition polie ont une fine couche d'imperméabilisant qui ne devrait être éliminée qu'après l'achèvement des travaux.
Con el fin de proteger la superficie de las piezas, los productos con acabado pulido tienen una fina capa de impermeabilizante, que solo debe eliminarse una vez terminado el trabajo.

(*) Peças produzidas de acordo com quantidades mínimas de 5m².

(*) Pieces produced in minimum quantities of 5m².

(*) Pièces produites selon des quantités minimales de 5m².

(*) Piezas producidas en cantidades mínimas de 5m².

40 cores
colors
couleurs
colores

10 formatos
formats
formats
formats

03 acabamentos
finishes
finitions
acabados

Full body

Ice	Superbranco	Branco	Bone
Platina	Arg prata	Iron	Carbon
Alloy	Titanium	Grafite	Antracite
Quartz	Luna	Lava	Astral
Café	Cacau	Preto	Jet

Bege	Duna	Citrus	Ocre
Coral	Brick	Terracotta	Malva
Opala	Cobalto	Indigo	Lazúli
Anis	Jade	Teal	Turquesa
Pistachio	Oliva	Palm	Clorofila

Full body

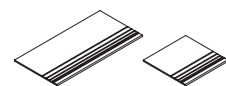

PEÇA _ PIECE

DG		Matt Nat	Matt Rect Soft	Pol
30x30 [29,6x29,6 cm]	Geral / General / Général / Standard / General	P08	P10	P10
	Cromática Alloy, Cromática Anis, Cromática Cacau, Cromática Citrus, Cromática Jade, Cromática Jet, Cromática Malva, Cromática Opala, Cromática Superbranco, Cromática Terracotta	P09	P13	P13
	Cromática Cobalto, Cromática Coral, Cromática Ice, Cromática Palm, Cromática Pistachio, Cromática Teal	P16	P20	P20
	Cromática Brick, Cromática Clorofila, Cromática Turquesa	-	P22	P22
	Cromática Indigo, Cromática Lazúli	-	P32	P32
30x60 [29,6x59,2 cm]	Geral / General / Général / Standard / General	P12	P18	P18
	Cromática Alloy, Cromática Anis, Cromática Cacau, Cromática Citrus, Cromática Jade, Cromática Jet, Cromática Malva, Cromática Opala, Cromática Superbranco, Cromática Terracotta	-	P24	P24
	Cromática Cobalto, Cromática Coral, Cromática Ice, Cromática Palm, Cromática Pistachio, Cromática Teal	-	P36	P36
	Cromática Brick, Cromática Clorofila, Cromática Turquesa	-	P42	P42
	Cromática Indigo, Cromática Lazúli	-	P97	P97
30x60x1,4 [29,6x59,2x1,4 cm]	Cromática Arg Prata, Cromática Astral, Cromática Branco, Cromática Grafite, Cromática Preto	-	P26	-
	Cromática Superbranco	-	P32	-
60x60 [59,2x59,2 cm]	Geral / General / Général / Standard / General	-	P36	P36
	Cromática Alloy, Cromática Anis, Cromática Cacau, Cromática Citrus, Cromática Jade, Cromática Jet, Cromática Malva, Cromática Opala, Cromática Superbranco, Cromática Terracotta	-	P46	P46
	Cromática Cobalto, Cromática Coral, Cromática Ice, Cromática Palm, Cromática Pistachio, Cromática Teal	-	P106	P106
	Cromática Brick, Cromática Clorofila, Cromática Turquesa	-	P118	P118
	Cromática Indigo, Cromática Lazúli	-	P157	P157
60x60x1,4 [59,2x59,2x1,4 cm]	Cromática Arg Prata, Cromática Astral, Cromática Branco, Cromática Grafite, Cromática Preto	-	P48	-
	Cromática Superbranco	-	P91	-
43,5x87 [43,5x87,0 cm]	Cromática Ice	-	P127	P127
45x90 [44,5x89,0 cm]	Cromática Antracite, Cromática Iron, Cromática Jet, Cromática Quartz, Cromática Superbranco	-	P97	P97
30x120 [29,6x118,4 cm]	Cromática Grafite, Cromática Preto, Cromática Superbranco	-	P97	P97
60x120 [59,2x118,4 cm]	Cromática Grafite, Cromática Preto, Cromática Superbranco	-	P167	P167

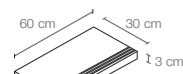

PEÇA _ PIECE

DG CF		Matt Rect Soft	Pol
30x60 [29,6x59,2 cm]	Geral / General / Général / Standard / General	P157	P157
	Cromática Brick, Cromática Clorofila, Cromática Turquesa	P197	P197
	Cromática Indigo, Cromática Lazúli	P237	P237

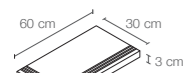

PEÇA _ PIECE

DG CF CANTO		Matt Rect Soft	Pol
30x60 [29,6x59,2 cm]	Geral / General / Général / Standard / General	P207	P207
	Cromática Brick, Cromática Clorofila, Cromática Turquesa	P247	P247
	Cromática Indigo, Cromática Lazúli	P287	P287

DG CF / DG CF Canto: Peças produzidas sob encomenda.
 DG CF / DG CF Canto: Pieces produced on order.
 DG CF / DG CF Canto: Pièces produites sur commande.
 DG CF / DG CF Canto: Piezas producidas por encargo.

DG CF Canto: Disponível em canto esquerdo e direito.
 DG CF Canto: Available in left and right corner.
 DG CF Canto: Disponible en angle gauche et droit.
 DG CF Canto: Canto izquierdo y derecho disponibles.

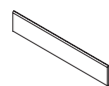

PEÇA _ PIECE

RB		Matt Nat	Matt Rect Soft	Pol
9,5x30 [9,5x29,6 cm]	Geral / General / Général / Standard / General	P07	P08	P08
	Cromática Brick, Cromática Cobalto, Cromática Clorofila, Cromática Coral, Cromática Ice, Cromática Palm, Cromática Pistachio, Cromática Teal, Cromática Turquesa	P08	P10	P10
	Cromática Indigo, Cromática Lazúli	-	P14	P14
8x43,5 [8x43,5 cm]	Cromática Ice	-	P20	P20
8x45 [8x44,5 cm]	Cromática Antracite, Cromática Iron, Cromática Jet, Cromática Quartz, Cromática Superbranco	-	P16	P16
8x60 [8x59,2 cm]	Geral / General / Général / Standard / General	-	P12	P12
	Cromática Brick, Cromática Cobalto, Cromática Clorofila, Cromática Coral, Cromática Ice, Cromática Palm, Cromática Pistachio, Cromática Teal, Cromática Turquesa	-	P20	P20
8x87 [8x87,0 cm]	Cromática Indigo, Cromática Lazúli	-	P28	P28
8x87 [8x87,0 cm]	Cromática Ice	-	P36	P36
8x90 [8x89,0 cm]	Cromática Antracite, Cromática Iron, Cromática Jet, Cromática Quartz, Cromática Superbranco	-	P28	P28
8x120 [8x118,4 cm]	Cromática Grafite, Cromática Preto, Cromática Superbranco	-	P28	P28



PEÇA _ PIECE

BR		Matt Nat	Matt Rect Soft	Pol
7x30 [7x29,6 cm]	Geral / General / Général / Standard / General	P05	P06	P06
	Cromática Brick, Cromática Clorofila, Cromática Ice, Cromática Turquesa	P06	P08	P08
	Cromática Indigo, Cromática Lazúli	-	P10	P10
7x60 [7x59,2 cm]	Geral / General / Général / Standard / General	-	P09	P09
	Cromática Cobalto, Cromática Coral, Cromática Ice, Cromática Palm, Cromática Pistachio, Cromática Teal	-	P12	P12
	Cromática Brick, Cromática Clorofila, Cromática Turquesa	-	P15	P15
	Cromática Indigo, Cromática Lazúli	-	P21	P21



PEÇA _ PIECE

TC		Matt Rect Soft	Pol
7x7 [7x7 cm]	Geral / General / Général / Standard / General	P01	P02
	Cromática Cobalto, Cromática Coral, Cromática Ice, Cromática Palm, Cromática Pistachio, Cromática Teal	P02	P04
	Cromática Brick, Cromática Clorofila, Cromática Indigo, Cromática Lazúli, Cromática Turquesa	P04	P05

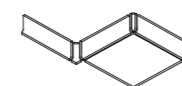

PEÇA _ PIECE

		Matt Nat
10x30	RBBC / RRBC	P09
	Cromática Branco, Cromática Platina, Cromática Preto, Cromática Superbranco	
03x10	AEBBC / AIBBC / AERBC / AIRBC	P09
	Cromática Branco, Cromática Platina, Cromática Preto, Cromática Superbranco	

Estas peças são produzidas de acordo com quantidades mínimas.
 These tiles are produced in minimum quantities.
 La fabrication de ces pièces est soumise à des quantités minimales.
 Estas piezas se producen en cantidades mínimas.



Cromática Jet
 Cromática Branco
 Cube Oliva
 Trio Spring Spirit

Cromática _ Chromatic

Full body

CROMÁTICA ICE

(*) 10x10	SOFT	[9,6x9,6x0,90 cm]	P183	V1	5	—	—	—	—	—	U4P4E3C2
30x30	MATT NAT	[...x0,77 cm]	P122	V1	5	class 2	A	R10	36*	≥0,42	U4P4E3C2
	MATT RECT	[29,6x29,6x0,90 cm]	P163	V1	5	class 2	A	R10	36*	≥0,42	U4P4E3C2
	SOFT	[29,6x29,6x0,90 cm]	P163	V1	5	—	—	—	—	—	U4P4E3C2
	POL	[29,6x29,6x0,85 cm]	P177	V1	3	—	—	—	—	—	U3P3E3C2
30x60	MATT RECT	[29,6x59,2x0,90 cm]	P163	V1	5	class 2	A	R10	36*	≥0,42	U4P3E3C2
	SOFT	[29,6x59,2x0,90 cm]	P163	V1	5	—	—	—	—	—	U4P3E3C2
	POL	[29,6x59,2x0,85 cm]	P177	V1	3	—	—	—	—	—	U3P3E3C2
60x60	MATT RECT	[59,2x59,2x0,90 cm]	P163	V1	5	class 2	A	R10	36*	≥0,42	U4P4E3C2
	SOFT	[59,2x59,2x0,90 cm]	P163	V1	5	—	—	—	—	—	U4P4E3C2
	POL	[59,2x59,2x0,85 cm]	P177	V1	3	—	—	—	—	—	U3P3E3C2
	MATT RECT	[87,0x87,0x1,05 cm]	P191	V1	5	class 2	A	R10	36*	≥0,42	U4P3E3C2
87x87	SOFT	[87,0x87,0x1,05 cm]	P191	V1	5	—	—	—	—	—	U4P3E3C2
	POL	[87,0x87,0x0,98 cm]	P211	V1	3	—	—	—	—	—	U3P3E3C2

CROMÁTICA SUPERBRANCO

(*) 10x10	SOFT	[9,6x9,6x0,85 cm]	P143	V1	5	—	—	—	—	—	U4P4E3C2
30x30	MATT NAT	[...x0,77 cm]	P92	V1	5	class 2	A	R10	36*	≥0,42	U4P4E3C2
	MATT RECT	[29,6x29,6x0,85 cm]	P123	V1	5	class 2	A	R10	36*	≥0,42	U4P4E3C2
	SOFT	[29,6x29,6x0,85 cm]	P123	V1	5	—	—	—	—	—	U4P4E3C2
	POL	[29,6x29,6x0,80 cm]	P137	V1	3	—	—	—	—	—	U3P3E3C2
30x60	MATT RECT	[29,6x59,2x0,85 cm]	P123	V1	5	class 2	A	R10	36*	≥0,42	U4P3E3C2
	SOFT	[29,6x59,2x0,85 cm]	P123	V1	5	—	—	—	—	—	U4P3E3C2
	POL	[29,6x59,2x0,80 cm]	P137	V1	3	—	—	—	—	—	U3P3E3C2
60x60	MATT RECT	[59,2x59,2x0,85 cm]	P123	V1	5	class 2	A	R10	36*	≥0,42	U4P4E3C2
	SOFT	[59,2x59,2x0,85 cm]	P123	V1	5	—	—	—	—	—	U4P4E3C2
	POL	[59,2x59,2x0,80 cm]	P137	V1	3	—	—	—	—	—	U3P3E3C2
60x120	MATT RECT	[59,2x118,4x0,98 cm]	P155	V1	5	class 2	A	R10	36*	≥0,42	U4P3E3C2
	SOFT	[59,2x118,4x0,98 cm]	P155	V1	5	—	—	—	—	—	U4P3E3C2
	POL	[59,2x118,4x0,93 cm]	P175	V1	3	—	—	—	—	—	U3P3E3C2
90x90	MATT RECT	[89,0x89,0x1,05 cm]	P151	V1	5	class 2	A	R10	36*	≥0,42	U4P3E3C2
	SOFT	[89,0x89,0x1,05 cm]	P151	V1	5	—	—	—	—	—	U4P3E3C2
	POL	[89,0x89,0x0,98 cm]	P171	V1	3	—	—	—	—	—	U3P3E3C2

CROMÁTICA SUPERBRANCO 14mm

60x60	MATT RECT	[59,2x59,2x1,40 cm]	P147	V1	5	class 1	—	R9	—	≥0,42	U4P4E3C2
-------	-----------	---------------------	------	----	---	---------	---	----	---	-------	----------

CROMÁTICA BRANCO

(*) 10x10	SOFT	[9,6x9,6x0,85 cm]	P119	V1	5	—	—	—	—	—	U4P4E3C2
30x30	MATT NAT	[...x0,77 cm]	P68	V1	5	class 2	A	R10	36*	≥0,42	U4P4E3C2
	MATT RECT	[29,6x29,6x0,85 cm]	P99	V1	5	class 2	A	R10	36*	≥0,42	U4P4E3C2
	SOFT	[29,6x29,6x0,85 cm]	P99	V1	5	—	—	—	—	—	U4P4E3C2
	POL	[29,6x29,6x0,80 cm]	P113	V1	3	—	—	—	—	—	U3P3E3C2
30x60	MATT RECT	[29,6x59,2x0,85 cm]	P99	V1	5	class 2	A	R10	36*	≥0,42	U4P3E3C2
	SOFT	[29,6x59,2x0,85 cm]	P99	V1	5	—	—	—	—	—	U4P3E3C2
	POL	[29,6x59,2x0,80 cm]	P113	V1	3	—	—	—	—	—	U3P3E3C2
60x60	MATT RECT	[59,2x59,2x0,90 cm]	P99	V1	5	class 2	A	R10	36*	≥0,42	U4P4E3C2
	SOFT	[59,2x59,2x0,90 cm]	P99	V1	5	—	—	—	—	—	U4P4E3C2
	POL	[59,2x59,2x0,80 cm]	P113	V1	3	—	—	—	—	—	U3P3E3C2

CROMÁTICA BRANCO 14mm

60x60	MATT RECT	[59,2x59,2x1,40 cm]	P123	V1	5	class 1	—	R9	—	≥0,42	U4P4E3C2
-------	-----------	---------------------	------	----	---	---------	---	----	---	-------	----------

CROMÁTICA BONE

(*) 10x10	SOFT	[9,6x9,6x0,85 cm]	P119	V1	5	—	—	—	—	—	U4P4E3C2
30x30	MATT RECT	[29,6x29,6x0,85 cm]	P99	V1	5	class 2	A	R10	36*	≥0,42	U4P4E3C2
	SOFT	[29,6x29,6x0,85 cm]	P99	V1	5	—	—	—	—	—	U4P4E3C2
	POL	[29,6x29,6x0,80 cm]	P113	V1	3	—	—	—	—	—	U3P3E3C2
30x60	MATT RECT	[29,6x59,2x0,85 cm]	P99	V1	5	class 2	A	R10	36*	≥0,42	U4P3E3C2
	SOFT	[29,6x59,2x0,85 cm]	P99	V1	5	—	—	—	—	—	U4P3E3C2
	POL	[29,6x59,2x0,80 cm]	P113	V1	3	—	—	—	—	—	U3P3E3C2
60x60	MATT RECT	[59,2x59,2x0,85 cm]	P99	V1	5	class 2	A	R10	36*	≥0,42	U4P4E3C2
	SOFT	[59,2x59,2x0,85 cm]	P99	V1	5	—	—	—	—	—	U4P4E3C2
	POL	[59,2x59,2x0,80 cm]	P113	V1	3	—	—	—	—	—	U3P3E3C2

(*) Peças produzidas de acordo com quantidades mínimas de 5m².

(*) Pieces produced in minimum quantities of 5m².

(*) Pièces produites selon des quantités minimales de 5m².

(*) Piezas producidas en cantidades mínimas de 5m².

Cromática _ Chromatic

Full body

CROMÁTICA PLATINA

(*) 10x10	SOFT	[9,6x9,6x0,85 cm]	P119	V1	5	—	—	—	—	—	U4P4E3C2
30x30	MATT NAT	[...x0,77 cm]	P68	V1	5	class 2	A	R10	36*	≥0,42	U4P4E3C2
	MATT RECT	[29,6x29,6x0,85 cm]	P99	V1	5	class 2	A	R10	36*	≥0,42	U4P4E3C2
	SOFT	[29,6x29,6x0,85 cm]	P99	V1	5	—	—	—	—	—	U4P4E3C2
	POL	[29,6x29,6x0,80 cm]	P113	V1	3	—	—	—	—	—	U3P3E3C2
30x60	MATT RECT	[29,6x59,2x0,85 cm]	P99	V1	5	class 2	A	R10	36*	≥0,42	U4P3E3C2
	SOFT	[29,6x59,2x0,85 cm]	P99	V1	5	—	—	—	—	—	U4P3E3C2
	POL	[29,6x59,2x0,80 cm]	P113	V1	3	—	—	—	—	—	U3P3E3C2
60x60	MATT RECT	[59,2x59,2x0,85 cm]	P99	V1	5	class 2	A	R10	36*	≥0,42	U4P3E3C2
	SOFT	[59,2x59,2x0,85 cm]	P99	V1	5	—	—	—	—	—	U4P3E3C2
	POL	[59,2x59,2x0,80 cm]	P113	V1	3	—	—	—	—	—	U3P3E3C2

CROMÁTICA ARG PRATA

(*) 10x10	SOFT	[9,6x9,6x0,85 cm]	P119	V1	5	—	—	—	—	—	U4P4E3C2
30x30	MATT RECT	[29,6x29,6x0,85 cm]	P99	V1	5	class 2	A	R10	36*	≥0,42	U4P4E3C2
	SOFT	[29,6x29,6x0,85 cm]	P99	V1	5	—	—	—	—	—	U4P4E3C2
	POL	[29,6x29,6x0,80 cm]	P113	V1	3	—	—	—	—	—	U3P3E3C2
	MATT RECT	[29,6x59,2x0,85 cm]	P99	V1	5	class 2	A	R10	36*	≥0,42	U4P3E3C2
30x60	SOFT	[29,6x59,2x0,85 cm]	P99	V1	5	—	—	—	—	—	U4P3E3C2
	POL	[29,6x59,2x0,80 cm]	P113	V1	3	—	—	—	—	—	U3P3E3C2
	MATT RECT	[59,2x59,2x0,85 cm]	P99	V1	5	class 2	A	R10	36*	≥0,42	U4P3E3C2
60x60	SOFT	[59,2x59,2x0,85 cm]	P99	V1	5	—	—	—	—	—	U4P3E3C2
	POL	[59,2x59,2x0,80 cm]	P113	V1	3	—	—	—	—	—	U3P3E3C2

CROMÁTICA ARG PRATA 14mm

60x60	MATT RECT	[59,2x59,2x1,40 cm]	P123	V1	5	class 1	—	R9	—	≥0,42	U4P4E3C2
-------	-----------	---------------------	------	----	---	---------	---	----	---	-------	----------

CROMÁTICA IRON

(*) 10x10	SOFT	[9,6x9,6x0,85 cm]	P119	V1	5	—	—	—	—	—	U4P4E3C2
30x30	MATT RECT	[29,6x29,6x0,85 cm]	P99	V1	5	class 2	A	R10	36*	≥0,42	U4P4E3C2
	SOFT	[29,6x29,6x0,85 cm]	P99	V1	5	—	—	—	—	—	U4P4E3C2
	POL	[29,6x29,6x0,80 cm]	P113	V1	3	—	—	—	—	—	U3P3E3C2
	MATT RECT	[29,6x59,2x0,85 cm]	P99	V1	5	class 2	A	R10	36*	≥0,42	U4P3E3C2
30x60	SOFT	[29,6x59,2x0,85 cm]	P99	V1	5	—	—	—	—	—	U4P3E3C2
	POL	[29,6x59,2x0,80 cm]	P113	V1	3	—	—	—	—	—	U3P3E3C2
	MATT RECT	[59,2x59,2x0,85 cm]	P99	V1	5	class 2	A	R10	36*	≥0,42	U4P4E3C2
60x60	SOFT	[59,2x59,2x0,85 cm]	P99	V1	5	—	—	—	—	—	U4P4E3C2
	POL	[59,2x59,2x0,80 cm]	P113	V1	3	—	—	—	—	—	U3P3E3C2
	MATT RECT	[89,0x89,0x1,05 cm]	P127	V1	5	class 2	A	R10	36*	≥0,42	U4P3E3C2
90x90	SOFT	[89,0x89,0x1,05 cm]	P127	V1	5	—	—	—	—	—	U4P3E3C2
	POL	[89,0x89,0x0,98 cm]	P147	V1	3	—	—	—	—	—	U3P3E3C2

CROMÁTICA CARBON

(*) 10x10	SOFT	[9,6x9,6x0,85 cm]	P119	V1	5	—	—	—	—	—	U4P4E3C2
30x30	SOFT	[29,6x29,6x0,85 cm]	P99	V1	5	—	—	—	—	—	U4P4E3C2
	POL	[29,6x29,6x0,80 cm]	P113	V1	3	—	—	—	—	—	U3P3E3C2
	SOFT	[29,6x59,2x0,85 cm]	P99	V1	5	—	—	—	—	—	U4P3E3C2
30x60	POL	[29,6x59,2x0,80 cm]	P113	V1	3	—	—	—	—	—	U3P3E3C2
	SOFT	[59,2x59,2x0,85 cm]	P99	V1	5	—	—	—	—	—	U4P4E3C2
60x60	POL	[59,2x59,2x0,80 cm]</									

CROMÁTICA ALLOY

(*) 10x10	SOFT	[9,6x9,6x0,85 cm]	P143	V1	5	—	—	—	—	—	U4P4E3C2
30x30	MATT RECT	[29,6x29,6x0,85 cm]	P123	V1	5	class 2	A	R10	36*	≥0,42	U4P4E3C2
	SOFT	[29,6x29,6x0,85 cm]	P123	V1	5	—	—	—	—	—	U4P4E3C2
	POL	[29,6x29,6x0,80 cm]	P137	V1	3	—	—	—	—	—	U3P3E3C2
30x60	MATT RECT	[29,6x59,2x0,85 cm]	P123	V1	5	class 2	A	R10	36*	≥0,42	U4P3E3C2
	SOFT	[29,6x59,2x0,85 cm]	P123	V1	5	—	—	—	—	—	U4P3E3C2
	POL	[29,6x59,2x0,80 cm]	P137	V1	3	—	—	—	—	—	U3P3E3C2
60x60	MATT RECT	[59,2x59,2x0,85 cm]	P123	V1	5	class 2	A	R10	36*	≥0,42	U4P4E3C2
	SOFT	[59,2x59,2x0,85 cm]	P123	V1	5	—	—	—	—	—	U4P4E3C2
	POL	[59,2x59,2x0,80 cm]	P137	V1	3	—	—	—	—	—	U3P3E3C2

CROMÁTICA TITANIUM

(*) 10x10	SOFT	[9,6x9,6x0,85 cm]	P119	V1	5	—	—	—	—	—	U4P4E3C2
30x30	MATT RECT	[29,6x29,6x0,85 cm]	P99	V1	5	class 2	A	R10	36*	≥0,42	U4P4E3C2
	SOFT	[29,6x29,6x0,85 cm]	P99	V1	5	—	—	—	—	—	U4P4E3C2
	POL	[29,6x29,6x0,80 cm]	P113	V1	3	—	—	—	—	—	U3P3E3C2
30x60	MATT RECT	[29,6x59,2x0,85 cm]	P99	V1	5	class 2	A	R10	36*	≥0,42	U4P3E3C2
	SOFT	[29,6x59,2x0,85 cm]	P99	V1	5	—	—	—	—	—	U4P3E3C2
	POL	[29,6x59,2x0,80 cm]	P113	V1	3	—	—	—	—	—	U3P3E3C2
60x60	MATT RECT	[59,2x59,2x0,85 cm]	P99	V1	5	class 2	A	R10	36*	≥0,42	U4P4E3C2
	SOFT	[59,2x59,2x0,85 cm]	P99	V1	5	—	—	—	—	—	U4P4E3C2
	POL	[59,2x59,2x0,80 cm]	P113	V1	3	—	—	—	—	—	U3P3E3C2

CROMÁTICA GRAFITE

(*) 10x10	SOFT	[9,6x9,6x0,85 cm]	P119	V1	5	—	—	—	—	—	U4P4E3C2
30x30	MATT RECT	[29,6x29,6x0,85 cm]	P99	V1	5	class 2	A	R10	36*	≥0,42	U4P4E3C2
	SOFT	[29,6x29,6x0,85 cm]	P99	V1	5	—	—	—	—	—	U4P4E3C2
	POL	[29,6x29,6x0,80 cm]	P113	V1	3	—	—	—	—	—	U3P3E3C2
30x60	MATT RECT	[29,6x59,2x0,85 cm]	P99	V1	5	class 2	A	R10	36*	≥0,42	U4P3E3C2
	SOFT	[29,6x59,2x0,85 cm]	P99	V1	5	—	—	—	—	—	U4P3E3C2
	POL	[29,6x59,2x0,80 cm]	P113	V1	3	—	—	—	—	—	U3P3E3C2
60x60	MATT RECT	[59,2x59,2x0,85 cm]	P99	V1	5	class 2	A	R10	36*	≥0,42	U4P4E3C2
	SOFT	[59,2x59,2x0,85 cm]	P99	V1	5	—	—	—	—	—	U4P4E3C2
	POL	[59,2x59,2x0,80 cm]	P113	V1	3	—	—	—	—	—	U3P3E3C2
60x120	MATT RECT	[59,2x118,4x0,98 cm]	P131	V1	5	class 2	A	R10	36*	≥0,42	U4P3E3C2
	SOFT	[59,2x118,4x0,98 cm]	P131	V1	5	—	—	—	—	—	U4P3E3C2
	POL	[59,2x118,4x0,93 cm]	P151	V1	3	—	—	—	—	—	U3P3E3C2

CROMÁTICA GRAFITE 14mm

60x60	MATT RECT	[59,2x59,2x1,40 cm]	P123	V1	5	class 1	—	R9	—	≥0,42	U4P4E3C2
-------	-----------	---------------------	------	----	---	---------	---	----	---	-------	----------

CROMÁTICA ANTRACITE

(*) 10x10	SOFT	[9,6x9,6x0,85 cm]	P119	V1	5	U4P4E3C2
30x30	SOFT	[29,6x29,6x0,85 cm]	P99	V1	5	U4P4E3C2
	POL	[29,6x29,6x0,80 cm]	P113	V1	3	U3P3E3C2
	SOFT	[29,6x59,2x0,85 cm]	P99	V1	5	U4P3E3C2
30x60	POL	[29,6x59,2x0,80 cm]	P113	V1	3	U3P3E3C2
	SOFT	[59,2x59,2x0,85 cm]	P99	V1	5	U4P4E3C2
	POL	[59,2x59,2x0,80 cm]	P113	V1	3	U3P3E3C2
60x60	SOFT	[89,0x89,0x1,05 cm]	P127	V1	5	U4P3E3C2
	POL	[89,0x89,0x0,98 cm]	P147	V1	3	U3P3E3C2

(*) Peças produzidas de acordo com quantidades mínimas de 5m².
 (*) Pieces produced in minimum quantities of 5m².
 (*) Pièces produites selon des quantités minimales de 5m².
 (*) Piezas producidas en cantidades mínimas de 5m².

CROMÁTICA QUARTZ

(*) 10x10	SOFT	[9,6x9,6x0,85 cm]	P119	V1	5	—	—	—	—	—	U4P4E3C2
30x30	MATT RECT	[29,6x29,6x0,85 cm]	P99	V1	5	class 2	A	R10	36*	≥0,42	U4P4E3C2
	SOFT	[29,6x29,6x0,85 cm]	P99	V1	5	—	—	—	—	—	U4P4E3C2
	POL	[29,6x29,6x0,80 cm]	P113	V1	3	—	—	—	—	—	U3P3E3C2
30x60	MATT RECT	[29,6x59,2x0,85 cm]	P99	V1	5	class 2	A	R10	36*	≥0,42	U4P3E3C2
	SOFT	[29,6x59,2x0,85 cm]	P99	V1	5	—	—	—	—	—	U4P3E3C2
	POL	[29,6x59,2x0,80 cm]	P113	V1	3	—	—	—	—	—	U3P3E3C2
60x60	MATT RECT	[59,2x59,2x0,85 cm]	P99	V1	5	class 2	A	R10	36*	≥0,42	U4P4E3C2
	SOFT	[59,2x59,2x0,85 cm]	P99	V1	5	—	—	—	—	—	U4P4E3C2
	POL	[59,2x59,2x0,80 cm]	P113	V1	3	—	—	—	—	—	U3P3E3C2
90x90	MATT RECT	[89,0x89,0x1,05 cm]	P127	V1	5	class 2	A	R10	36*	≥0,42	U4P3E3C2
	SOFT	[89,0x89,0x1,05 cm]	P127	V1	5	—	—	—	—	—	U4P3E3C2
	POL	[89,0x89,0x0,98 cm]	P147	V1	3	—	—	—	—	—	U3P3E3C2

CROMÁTICA LUNA

(*) 10x10	SOFT	[9,6x9,6x0,85 cm]	P119	V1	5	—	—	—	—	—	U4P4E3C2
30x30	MATT RECT	[29,6x29,6x0,85 cm]	P99	V1	5	class 2	A	R10	36*	≥0,42	U4P4E3C2
	SOFT	[29,6x29,6x0,85 cm]	P99	V1	5	—	—	—	—	—	U4P4E3C2
	POL	[29,6x29,6x0,80 cm]	P113	V1	3	—	—	—	—	—	U3P3E3C2
30x60	MATT RECT	[29,6x59,2x0,85 cm]	P99	V1	5	class 2	A	R10	36*	≥0,42	U4P3E3C2
	SOFT	[29,6x59,2x0,85 cm]	P99	V1	5	—	—	—	—	—	U4P3E3C2
	POL	[29,6x59,2x0,80 cm]	P113	V1	3	—	—	—	—	—	U3P3E3C2
60x60	MATT RECT	[59,2x59,2x0,85 cm]	P99	V1	5	class 2	A	R10	36*	≥0,42	U4P4E3C2
	SOFT	[59,2x59,2x0,85 cm]	P99	V1	5	—	—	—	—	—	U4P4E3C2
	POL	[59,2x59,2x0,80 cm]	P113	V1	3	—	—	—	—	—	U3P3E3C2

CROMÁTICA LAVA

(*) 10x10	SOFT	[9,6x9,6x0,85 cm]	P119	V1	5	—	—	—	—	—	U4P4E3C2
30x30	MATT RECT	[29,6x29,6x0,85 cm]	P99	V1	5	class 2	A	R10	36*	≥0,42	U4P4E3C2
	SOFT	[29,6x29,6x0,85 cm]	P99	V1	5	—	—	—	—	—	U4P4E3C2
	POL	[29,6x29,6x0,80 cm]	P113	V1	3	—	—	—	—	—	U3P3E3C2
30x60	MATT RECT	[29,6x59,2x0,85 cm]	P99	V1	5	class 2	A	R10	36*	≥0,42	U4P3E3C2
	SOFT	[29,6x59,2x0,85 cm]	P99	V1	5	—	—	—	—	—	U4P3E3C2
	POL	[29,6x59,2x0,80 cm]	P113	V1	3	—	—	—	—	—	U3P3E3C2
60x60	MATT RECT	[59,2x59,2x0,85 cm]	P99	V1	5	class 2	A	R10	36*	≥0,42	U4P4E3C2
	SOFT	[59,2x59,2x0,85 cm]	P99	V1	5	—	—	—	—	—	U4P4E3C2
	POL	[59,2x59,2x0,80 cm]	P113	V1	3	—	—	—	—	—	U3P3E3C2

CROMÁTICA ASTRAL

(*) 10x10	SOFT	[9,6x9,6x0,85 cm]	P119	V1	5	U4P4E3C2
30x30	SOFT	[29,6x29,6x0,85 cm]	P99	V1	5	U4P4E3C2
	POL	[29,6x29,6x0,80 cm]	P113	V1	3	U3P3E3C2
	SOFT	[29,6x59,2x0,85 cm]	P99	V1	5	U4P3E3C2
30x60	POL	[29,6x59,2x0,80 cm]	P113	V1	3	U3P3E3C2
	SOFT	[59,2x59,2x0,85 cm]	P99	V1	5	U4P4E3C2
	POL	[59,2x59,2x0,80 cm]	P113	V1	3	U3P3E3C2

CROMÁTICA ASTRAL 14mm

60x60	MATT RECT	[59,2x59,2x1,40 cm]	P123	V1	5	class 1	—	R9	—	≥0,42	U4P4E3C2
-------	-----------	---------------------	------	----	---	---------	---	----	---	-------	----------

(*) Peças produzidas de acordo com quantidades mínimas de 5m².
 (*) Pieces produced in minimum quantities of 5m².
 (*) Pièces produites selon des quantités minimales de 5m².
 (*) Piezas producidas en cantidades mínimas de 5m².

Cromática _ Chromatic

Full body

CROMÁTICA CAFÉ

(*) 10x10	SOFT	[9,6x9,6x0,85 cm]	P119	V1	5	—	—	—	—	U4P4E3C2	
30x30	MATT RECT	[29,6x29,6x0,85 cm]	P99	V1	5	class 2	A	R10	36*	≥0,42	U4P4E3C2
	SOFT	[29,6x29,6x0,85 cm]	P99	V1	5	—	—	—	—	—	U4P4E3C2
	POL	[29,6x29,6x0,80 cm]	P113	V1	3	—	—	—	—	—	U3P3E3C2
30x60	MATT RECT	[29,6x59,2x0,85 cm]	P99	V1	5	class 2	A	R10	36*	≥0,42	U4P3E3C2
	SOFT	[29,6x59,2x0,85 cm]	P99	V1	5	—	—	—	—	—	U4P3E3C2
	POL	[29,6x59,2x0,80 cm]	P113	V1	3	—	—	—	—	—	U3P3E3C2
60x60	MATT RECT	[59,2x59,2x0,85 cm]	P99	V1	5	class 2	A	R10	36*	≥0,42	U4P4E3C2
	SOFT	[59,2x59,2x0,85 cm]	P99	V1	5	—	—	—	—	—	U4P4E3C2
	POL	[59,2x59,2x0,80 cm]	P113	V1	3	—	—	—	—	—	U3P3E3C2

CROMÁTICA CACAU

(*) 10x10	SOFT	[9,6x9,6x0,85 cm]	P143	V1	5	—	—	—	—	U4P4E3C2	
30x30	SOFT	[29,6x29,6x0,85 cm]	P123	V1	5	—	—	—	—	—	U4P4E3C2
	POL	[29,6x29,6x0,80 cm]	P137	V1	3	—	—	—	—	—	U3P3E3C2
	30x60	SOFT	[29,6x59,2x0,85 cm]	P123	V1	5	—	—	—	—	—
POL		[29,6x59,2x0,80 cm]	P137	V1	3	—	—	—	—	—	U3P3E3C2
60x60		SOFT	[59,2x59,2x0,85 cm]	P123	V1	5	—	—	—	—	—
	POL	[59,2x59,2x0,80 cm]	P137	V1	3	—	—	—	—	—	U3P3E3C2

CROMÁTICA PRETO

(*) 10x10	SOFT	[9,6x9,6x0,85 cm]	P119	V1	5	—	—	—	—	U4P4E3C2	
30x30	NAT	[...x0,77 cm]	P68	V1	5	—	—	—	—	—	U4P4E3C2
	SOFT	[29,6x29,6x0,85 cm]	P99	V1	5	—	—	—	—	—	U4P4E3C2
	POL	[29,6x29,6x0,80 cm]	P113	V1	3	—	—	—	—	—	U3P3E3C2
30x60	SOFT	[29,6x59,2x0,85 cm]	P99	V1	5	—	—	—	—	—	U4P3E3C2
	POL	[29,6x59,2x0,80 cm]	P113	V1	3	—	—	—	—	—	U3P3E3C2
	60x60	SOFT	[59,2x59,2x0,85 cm]	P99	V1	5	—	—	—	—	—
POL		[59,2x59,2x0,80 cm]	P113	V1	3	—	—	—	—	—	U3P3E3C2
60x120		SOFT	[59,2x118,4x0,93 cm]	P131	V1	5	—	—	—	—	—
	POL	[59,2x118,4x0,93 cm]	P151	V1	3	—	—	—	—	—	U3P3E3C2

CROMÁTICA PRETO 14mm

60x60	MATT RECT	[59,2x59,2x1,40 cm]	P123	V1	5	class 1	—	R9	—	≥0,42	U4P4E3C2
-------	-----------	---------------------	------	----	---	---------	---	----	---	-------	----------

CROMÁTICA JET

(*) 10x10	SOFT	[9,6x9,6x0,85 cm]	P143	V1	5	—	—	—	—	U4P4E3C2	
30x30	SOFT	[29,6x29,6x0,85 cm]	P123	V1	5	—	—	—	—	—	U4P4E3C2
	POL	[29,6x29,6x0,80 cm]	P137	V1	3	—	—	—	—	—	U3P3E3C2
	30x60	SOFT	[29,6x59,2x0,85 cm]	P123	V1	5	—	—	—	—	—
POL		[29,6x59,2x0,80 cm]	P137	V1	3	—	—	—	—	—	U3P3E3C2
60x60		SOFT	[59,2x59,2x0,85 cm]	P123	V1	5	—	—	—	—	—
	POL	[59,2x59,2x0,80 cm]	P137	V1	3	—	—	—	—	—	U3P3E3C2
	90x90	SOFT	[89,0x89,0x1,05 cm]	P151	V1	5	—	—	—	—	—
POL		[89,0x89,0x0,98 cm]	P171	V1	3	—	—	—	—	—	U3P3E3C2

(*) Peças produzidas de acordo com quantidades mínimas de 5m².

(*) Pieces produced in minimum quantities of 5m².

(*) Pièces produites selon des quantités minimales de 5m².

(*) Piezas producidas en cantidades mínimas de 5m².

Cromática _ Chromatic

Full body

CROMÁTICA BEGE

(*) 10x10	SOFT	[9,6x9,6x0,85 cm]	P119	V1	5	—	—	—	—	—	U4P4E3C2
30x30	MATT RECT	[29,6x29,6x0,85 cm]	P99	V1	5	class 2	A	R10	36*	≥0,42	U4P4E3C2
	SOFT	[29,6x29,6x0,85 cm]	P99	V1	5	—	—	—	—	—	U4P4E3C2
	POL	[29,6x29,6x0,80 cm]	P113	V1	3	—	—	—	—	—	U3P3E3C2
30x60	MATT RECT	[29,6x59,2x0,85 cm]	P99	V1	5	class 2	A	R10	36*	≥0,42	U4P3E3C2
	SOFT	[29,6x59,2x0,85 cm]	P99	V1	5	—	—	—	—	—	U4P3E3C2
	POL	[29,6x59,2x0,80 cm]	P113	V1	3	—	—	—	—	—	U3P3E3C2
60x60	MATT RECT	[59,2x59,2x0,85 cm]	P99	V1	5	class 2	A	R10	36*	≥0,42	U4P4E3C2
	SOFT	[59,2x59,2x0,85 cm]	P99	V1	5	—	—	—	—	—	U4P4E3C2
	POL	[59,2x59,2x0,80 cm]	P113	V1	3	—	—	—	—	—	U3P3E3C2

CROMÁTICA DUNA

(*) 10x10	SOFT	[9,6x9,6x0,85 cm]	P119	V1	5	—	—	—	—	—	U4P4E3C2
30x30	MATT RECT	[29,6x29,6x0,85 cm]	P99	V1	5	class 2	A	R10	36*	≥0,42	U4P4E3C2
	SOFT	[29,6x29,6x0,85 cm]	P99	V1	5	—	—	—	—	—	U4P4E3C2
	POL	[29,6x29,6x0,80 cm]	P113	V1	3	—	—	—	—	—	U3P3E3C2
30x60	MATT RECT	[29,6x59,2x0,85 cm]	P99	V1	5	class 2	A	R10	36*	≥0,42	U4P3E3C2
	SOFT	[29,6x59,2x0,85 cm]	P99	V1	5	—	—	—	—	—	U4P3E3C2
	POL	[29,6x59,2x0,80 cm]	P113	V1	3	—	—	—	—	—	U3P3E3C2
60x60	MATT RECT	[59,2x59,2x0,85 cm]	P99	V1	5	class 2	A	R10	36*	≥0,42	U4P4E3C2
	SOFT	[59,2x59,2x0,85 cm]	P99	V1	5	—	—	—	—	—	U4P4E3C2
	POL	[59,2x59,2x0,80 cm]	P113	V1	3	—	—	—	—	—	U3P3E3C2

CROMÁTICA CITRUS

(*) 10x10	SOFT	[9,6x9,6x0,85 cm]	P143	V1	5	—	—	—	—	—	U4P4E3C2
30x30	MATT RECT	[29,6x29,6x0,85 cm]	P123	V1	5	class 2	A	R10	36*	≥0,42	U4P4E3C2
	SOFT	[29,6x29,6x0,85 cm]	P123	V1	5	—	—	—	—	—	U4P4E3C2
	POL	[29,6x29,6x0,80 cm]	P137	V1	3	—	—	—	—	—	U3P3E3C2
30x60	MATT RECT	[29,6x59,2x0,85 cm]	P123	V1	5	class 2	A	R10	36*	≥0,42	U4P3E3C2
	SOFT	[29,6x59,2x0,85 cm]	P123	V1	5	—	—	—	—	—	U4P3E3C2
	POL	[29,6x59,2x0,80 cm]	P137	V1	3	—	—	—	—	—	U3P3E3C2
60x60	MATT RECT	[59,2x59,2x0,85 cm]	P123	V1	5	class 2	A	R10	36*	≥0,42	U4P4E3C2
	SOFT	[59,2x59,2x0,85 cm]	P123	V1	5	—	—	—	—	—	U4P4E3C2
	POL	[59,2x59,2x0,80 cm]	P137	V1	3	—	—	—	—	—	U3P3E3C2

CROMÁTICA OCRE

(*) 10x10	SOFT	[9,6x9,6x0,85 cm]	P119	V1	5	—	—	—	—	—	U4P4E3C2
30x30	MATT RECT	[29,6x29,6x0,85 cm]	P99	V1	5	class 2	A	R10	36*	≥0,42	U4P4E3C2
	SOFT	[29,6x29,6x0,85 cm]	P99	V1	5	—	—	—	—	—	U4P4E3C2
	POL	[29,6x29,6x0,80 cm]	P113	V1	3	—	—	—	—	—	U3P3E3C2
30x60	MATT RECT	[29,6x59,2x0,85 cm]	P99	V1	5	class 2	A	R10	36*	≥0,42	U4P3E3C2
	SOFT	[29,6x59,2x0,85 cm]	P99	V1	5	—	—	—	—	—	U4P3E3C2
	POL	[29,6x59,2x0,80 cm]	P113	V1	3	—	—	—	—	—	U3P3E3C2
60x60	MATT RECT	[59,2x59,2x0,85 cm]	P99	V1	5	class 2	A	R10	36*	≥0,42	U4P4E3C2
	SOFT	[59,2x59,2x0,85 cm]	P99	V1	5	—	—	—	—	—	U4P4E3C2
	POL	[59,2x59,2x0,80 cm]	P113	V1	3	—	—	—	—	—	U3P3E3C2

(*) Peças produzidas de acordo com quantidades mínimas de 5m².

(*) Pieces produced in minimum quantities of 5m².

(*) Pièces produites selon des quantités minimales de 5m².

(*) Piezas producidas en cantidades mínimas de 5m².

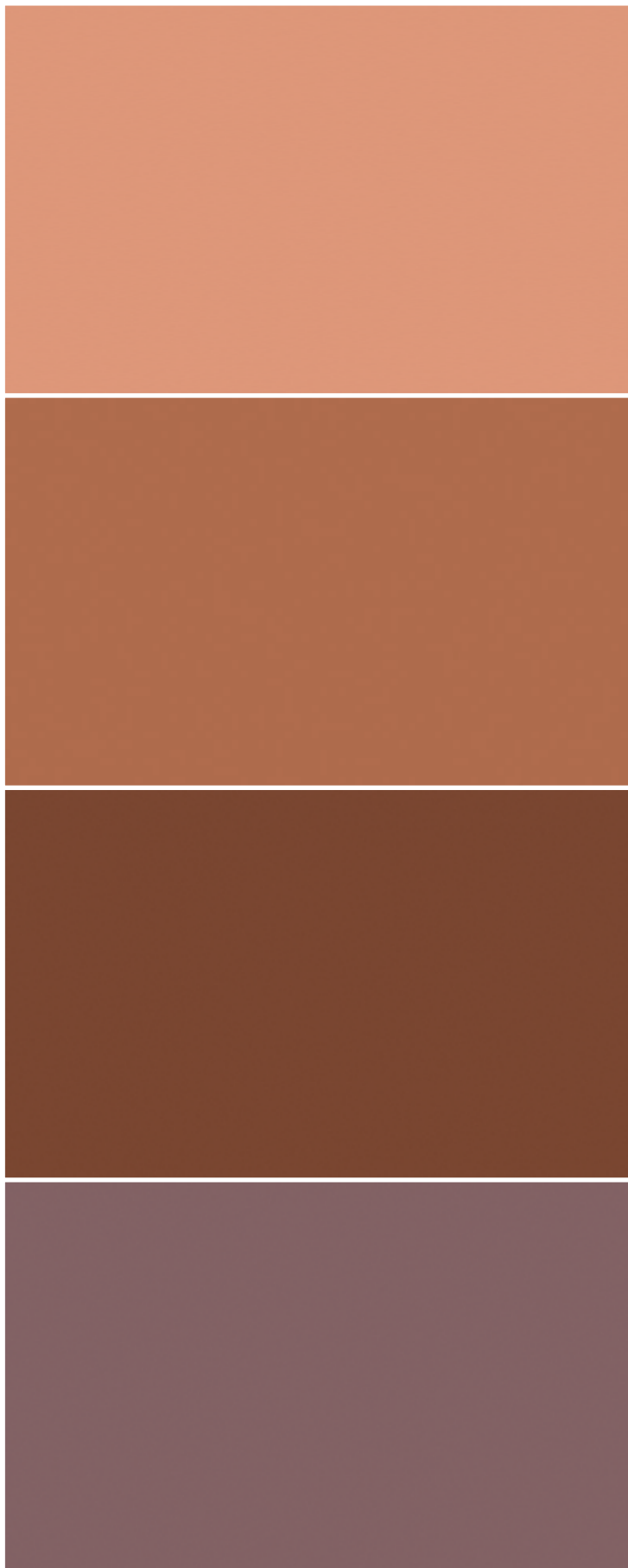

CROMÁTICA CORAL

(*) 10x10	SOFT	[9,6x9,6x0,85 cm]	P183	V1	5	—	—	—	—	—	U4P4E3C2
30x30	MATT RECT	[29,6x29,6x0,85 cm]	P163	V1	5	class 2	A	R10	36*	≥0,42	U4P4E3C2
	SOFT	[29,6x29,6x0,85 cm]	P163	V1	5	—	—	—	—	—	U4P4E3C2
	POL	[29,6x29,6x0,80 cm]	P177	V1	3	—	—	—	—	—	U3P3E3C2
30x60	MATT RECT	[29,6x59,2x0,85 cm]	P163	V1	5	class 2	A	R10	36*	≥0,42	U4P4E3C2
	SOFT	[29,6x59,2x0,85 cm]	P163	V1	5	—	—	—	—	—	U4P4E3C2
	POL	[29,6x59,2x0,80 cm]	P177	V1	3	—	—	—	—	—	U3P3E3C2
60x60	MATT RECT	[59,2x59,2x0,85 cm]	P163	V1	5	class 2	A	R10	36*	≥0,42	U4P4E3C2
	SOFT	[59,2x59,2x0,85 cm]	P163	V1	5	—	—	—	—	—	U4P4E3C2
	POL	[59,2x59,2x0,80 cm]	P177	V1	3	—	—	—	—	—	U3P3E3C2

CROMÁTICA BRICK

(*) 10x10	SOFT	[9,6x9,6x0,85 cm]	P237	V1	5	—	—	—	—	—	U4P4E3C2
30x30	MATT RECT	[29,6x29,6x0,85 cm]	P217	V1	5	class 2	A	R10	36*	≥0,42	U4P4E3C2
	SOFT	[29,6x29,6x0,85 cm]	P217	V1	5	—	—	—	—	—	U4P4E3C2
	POL	[29,6x29,6x0,80 cm]	P231	V1	3	—	—	—	—	—	U3P3E3C2
30x60	MATT RECT	[29,6x59,2x0,85 cm]	P217	V1	5	class 2	A	R10	36*	≥0,42	U4P4E3C2
	SOFT	[29,6x59,2x0,85 cm]	P217	V1	5	—	—	—	—	—	U4P4E3C2
	POL	[29,6x59,2x0,80 cm]	P231	V1	3	—	—	—	—	—	U3P3E3C2
60x60	MATT RECT	[59,2x59,2x0,85 cm]	P217	V1	5	class 2	A	R10	36*	≥0,42	U4P4E3C2
	SOFT	[59,2x59,2x0,85 cm]	P217	V1	5	—	—	—	—	—	U4P4E3C2
	POL	[59,2x59,2x0,80 cm]	P231	V1	3	—	—	—	—	—	U3P3E3C2

CROMÁTICA TERRACOTTA

(*) 10x10	SOFT	[9,6x9,6x0,85 cm]	P143	V1	5	U4P4E3C2
30x30	SOFT	[29,6x29,6x0,85 cm]	P123	V1	5	U4P4E3C2
	POL	[29,6x29,6x0,80 cm]	P137	V1	3	U3P3E3C2
	SOFT	[29,6x59,2x0,85 cm]	P123	V1	5	U4P4E3C2
30x60	POL	[29,6x59,2x0,80 cm]	P137	V1	3	U3P3E3C2
	SOFT	[59,2x59,2x0,85 cm]	P123	V1	5	U4P4E3C2
60x60	POL	[59,2x59,2x0,80 cm]	P137	V1	3	U3P3E3C2

CROMÁTICA MALVA

(*) 10x10	SOFT	[9,6x9,6x0,85 cm]	P143	V1	5	U4P4E3C2
30x30	SOFT	[29,6x29,6x0,85 cm]	P123	V1	5	U4P4E3C2
	POL	[29,6x29,6x0,80 cm]	P137	V1	3	U3P3E3C2
	SOFT	[29,6x59,2x0,85 cm]	P123	V1	5	U4P4E3C2
30x60	POL	[29,6x59,2x0,80 cm]	P137	V1	3	U3P3E3C2
	SOFT	[59,2x59,2x0,85 cm]	P123	V1	5	U4P4E3C2
60x60	POL	[59,2x59,2x0,80 cm]	P137	V1	3	U3P3E3C2

(*) Peças produzidas de acordo com quantidades mínimas de 5m².
 (*) Pieces produced in minimum quantities of 5m².
 (*) Pièces produites selon des quantités minimales de 5m².
 (*) Piezas producidas en cantidades mínimas de 5m².

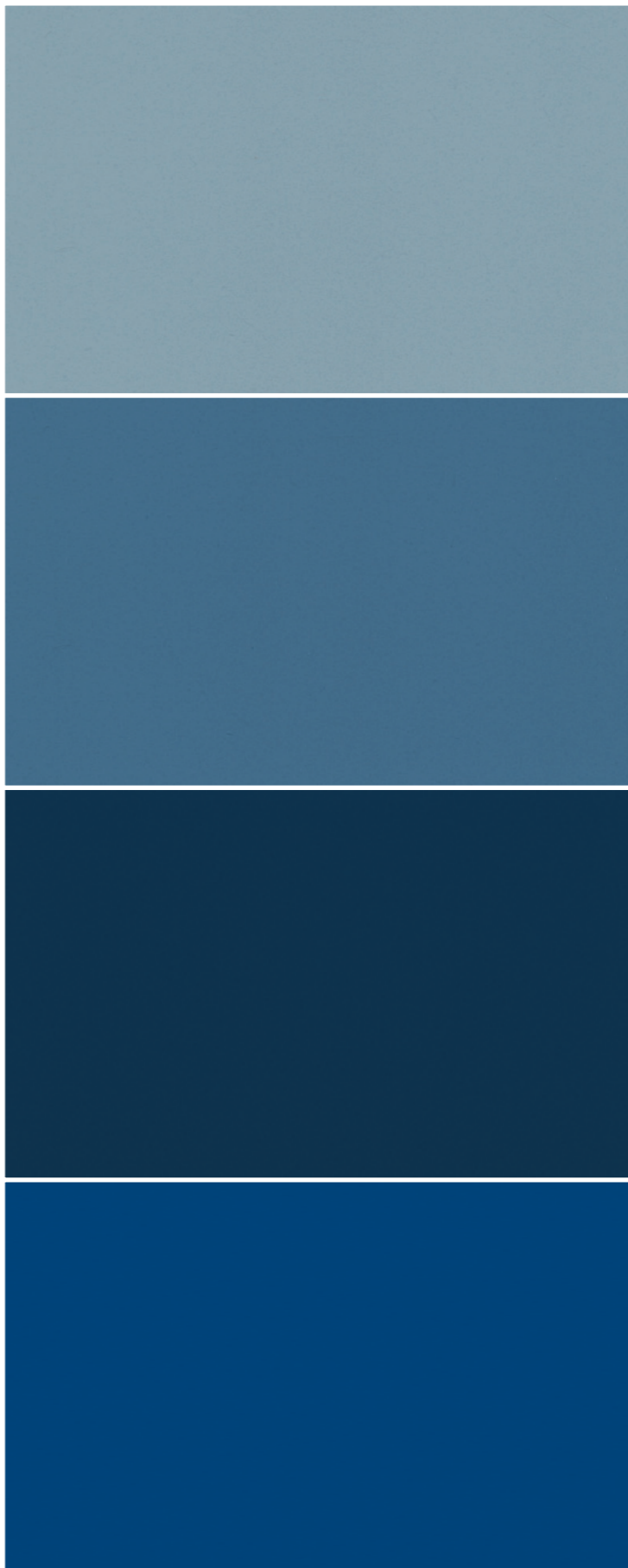

CROMÁTICA OPALA

(*) 10x10	SOFT	[9,6x9,6x0,85 cm]	P143	V1	5	—	—	—	—	—	U4P4E3C2
30x30	MATT RECT	[29,6x29,6x0,85 cm]	P123	V1	5	class 2	A	R10	36*	≥0,42	U4P4E3C2
	SOFT	[29,6x29,6x0,85 cm]	P123	V1	5	—	—	—	—	—	U4P4E3C2
	POL	[29,6x29,6x0,80 cm]	P137	V1	3	—	—	—	—	—	U3P3E3C2
30x60	MATT RECT	[29,6x59,2x0,85 cm]	P123	V1	5	class 2	A	R10	36*	≥0,42	U4P4E3C2
	SOFT	[29,6x59,2x0,85 cm]	P123	V1	5	—	—	—	—	—	U4P4E3C2
	POL	[29,6x59,2x0,80 cm]	P137	V1	3	—	—	—	—	—	U3P3E3C2
60x60	MATT RECT	[59,2x59,2x0,85 cm]	P123	V1	5	class 2	A	R10	36*	≥0,42	U4P4E3C2
	SOFT	[59,2x59,2x0,85 cm]	P123	V1	5	—	—	—	—	—	U4P4E3C2
	POL	[59,2x59,2x0,80 cm]	P137	V1	3	—	—	—	—	—	U3P3E3C2

CROMÁTICA COBALTO

(*) 10x10	SOFT	[9,6x9,6x0,85 cm]	P183	V1	5	—	—	—	—	—	U4P4E3C2
30x30	MATT RECT	[29,6x29,6x0,85 cm]	P163	V1	5	class 2	A	R10	36*	≥0,42	U4P4E3C2
	SOFT	[29,6x29,6x0,85 cm]	P163	V1	5	—	—	—	—	—	U4P4E3C2
	POL	[29,6x29,6x0,80 cm]	P177	V1	3	—	—	—	—	—	U3P3E3C2
30x60	MATT RECT	[29,6x59,2x0,85 cm]	P163	V1	5	class 2	A	R10	36*	≥0,42	U4P4E3C2
	SOFT	[29,6x59,2x0,85 cm]	P163	V1	5	—	—	—	—	—	U4P4E3C2
	POL	[29,6x59,2x0,80 cm]	P177	V1	3	—	—	—	—	—	U3P3E3C2
60x60	MATT RECT	[59,2x59,2x0,85 cm]	P163	V1	5	class 2	A	R10	36*	≥0,42	U4P4E3C2
	SOFT	[59,2x59,2x0,85 cm]	P163	V1	5	—	—	—	—	—	U4P4E3C2
	POL	[59,2x59,2x0,80 cm]	P177	V1	3	—	—	—	—	—	U3P3E3C2

CROMÁTICA INDIGO

(*) 10x10	SOFT	[9,6x9,6x0,85 cm]	P337	V1	5	U4P4E3C2
30x30	SOFT	[29,6x29,6x0,85 cm]	P317	V1	5	U4P4E3C2
	POL	[29,6x29,6x0,80 cm]	P331	V1	3	U3P3E3C2
	SOFT	[29,6x59,2x0,85 cm]	P317	V1	5	U4P4E3C2
30x60	POL	[29,6x59,2x0,80 cm]	P331	V1	3	U3P3E3C2
	SOFT	[59,2x59,2x0,85 cm]	P317	V1	5	U4P4E3C2
60x60	POL	[59,2x59,2x0,80 cm]	P331	V1	3	U3P3E3C2

CROMÁTICA LAZÚLI

(*) 10x10	SOFT	[9,6x9,6x0,85 cm]	P337	V1	5	U4P4E3C2
30x30	SOFT	[29,6x29,6x0,85 cm]	P317	V1	5	U4P4E3C2
	POL	[29,6x29,6x0,80 cm]	P331	V1	3	U3P3E3C2
	SOFT	[29,6x59,2x0,85 cm]	P317	V1	5	U4P4E3C2
30x60	POL	[29,6x59,2x0,80 cm]	P331	V1	3	U3P3E3C2
	SOFT	[59,2x59,2x0,85 cm]	P317	V1	5	U4P4E3C2
60x60	POL	[59,2x59,2x0,80 cm]	P331	V1	3	U3P3E3C2

(*) Peças produzidas de acordo com quantidades mínimas de 5m².
 (*) Pieces produced in minimum quantities of 5m².
 (*) Pièces produites selon des quantités minimales de 5m².
 (*) Piezas producidas en cantidades mínimas de 5m².



CROMÁTICA ANIS

(*) 10x10	SOFT	[9,6x9,6x0,85 cm]	P143	V1	A	5	—	—	—	—	—	—	U4P4E3C2
30x30	MATT RECT	[29,6x29,6x0,85 cm]	P123	V1	A <td>5</td> <td>class 2</td> <td>A</td> <td>R10</td> <td>36*</td> <td>≥0,42</td> <td>U4P4E3C2</td>	5	class 2	A	R10	36*	≥0,42	U4P4E3C2	
	SOFT	[29,6x29,6x0,85 cm]	P123	V1	A <td>5</td> <td>—</td> <td>—</td> <td>—</td> <td>—</td> <td>—</td> <td>U4P4E3C2</td>	5	—	—	—	—	—	U4P4E3C2	
	POL	[29,6x29,6x0,80 cm]	P137	V1	A <td>3</td> <td>—</td> <td>—</td> <td>—</td> <td>—</td> <td>—</td> <td>U3P3E3C2</td>	3	—	—	—	—	—	U3P3E3C2	
30x60	MATT RECT	[29,6x59,2x0,85 cm]	P123	V1	A <td>5</td> <td>class 2</td> <td>A</td> <td>R10</td> <td>36*</td> <td>≥0,42</td> <td>U4P4E3C2</td>	5	class 2	A	R10	36*	≥0,42	U4P4E3C2	
	SOFT	[29,6x59,2x0,85 cm]	P123	V1	A <td>5</td> <td>—</td> <td>—</td> <td>—</td> <td>—</td> <td>—</td> <td>U4P4E3C2</td>	5	—	—	—	—	—	U4P4E3C2	
	POL	[29,6x59,2x0,80 cm]	P137	V1	A <td>3</td> <td>—</td> <td>—</td> <td>—</td> <td>—</td> <td>—</td> <td>U3P3E3C2</td>	3	—	—	—	—	—	U3P3E3C2	
60x60	MATT RECT	[59,2x59,2x0,85 cm]	P123	V1	A <td>5</td> <td>class 2</td> <td>A</td> <td>R10</td> <td>36*</td> <td>≥0,42</td> <td>U4P4E3C2</td>	5	class 2	A	R10	36*	≥0,42	U4P4E3C2	
	SOFT	[59,2x59,2x0,85 cm]	P123	V1	A <td>5</td> <td>—</td> <td>—</td> <td>—</td> <td>—</td> <td>—</td> <td>U4P4E3C2</td>	5	—	—	—	—	—	U4P4E3C2	
	POL	[59,2x59,2x0,80 cm]	P137	V1	A <td>3</td> <td>—</td> <td>—</td> <td>—</td> <td>—</td> <td>—</td> <td>U3P3E3C2</td>	3	—	—	—	—	—	U3P3E3C2	

CROMÁTICA JADE

(*) 10x10	SOFT	[9,6x9,6x0,85 cm]	P143	V1	A	5	—	—	—	—	—	—	U4P4E3C2
30x30	MATT RECT	[29,6x29,6x0,85 cm]	P123	V1	A <td>5</td> <td>class 2</td> <td>A</td> <td>R10</td> <td>36*</td> <td>≥0,42</td> <td>U4P4E3C2</td>	5	class 2	A	R10	36*	≥0,42	U4P4E3C2	
	SOFT	[29,6x29,6x0,85 cm]	P123	V1	A <td>5</td> <td>—</td> <td>—</td> <td>—</td> <td>—</td> <td>—</td> <td>U4P4E3C2</td>	5	—	—	—	—	—	U4P4E3C2	
	POL	[29,6x29,6x0,80 cm]	P137	V1	A <td>3</td> <td>—</td> <td>—</td> <td>—</td> <td>—</td> <td>—</td> <td>U3P3E3C2</td>	3	—	—	—	—	—	U3P3E3C2	
30x60	MATT RECT	[29,6x59,2x0,85 cm]	P123	V1	A <td>5</td> <td>class 2</td> <td>A</td> <td>R10</td> <td>36*</td> <td>≥0,42</td> <td>U4P4E3C2</td>	5	class 2	A	R10	36*	≥0,42	U4P4E3C2	
	SOFT	[29,6x59,2x0,85 cm]	P123	V1	A <td>5</td> <td>—</td> <td>—</td> <td>—</td> <td>—</td> <td>—</td> <td>U4P4E3C2</td>	5	—	—	—	—	—	U4P4E3C2	
	POL	[29,6x59,2x0,80 cm]	P137	V1	A <td>3</td> <td>—</td> <td>—</td> <td>—</td> <td>—</td> <td>—</td> <td>U3P3E3C2</td>	3	—	—	—	—	—	U3P3E3C2	
60x60	MATT RECT	[59,2x59,2x0,85 cm]	P123	V1	A <td>5</td> <td>class 2</td> <td>A</td> <td>R10</td> <td>36*</td> <td>≥0,42</td> <td>U4P4E3C2</td>	5	class 2	A	R10	36*	≥0,42	U4P4E3C2	
	SOFT	[59,2x59,2x0,85 cm]	P123	V1	A <td>5</td> <td>—</td> <td>—</td> <td>—</td> <td>—</td> <td>—</td> <td>U4P4E3C2</td>	5	—	—	—	—	—	U4P4E3C2	
	POL	[59,2x59,2x0,80 cm]	P137	V1	A <td>3</td> <td>—</td> <td>—</td> <td>—</td> <td>—</td> <td>—</td> <td>U3P3E3C2</td>	3	—	—	—	—	—	U3P3E3C2	

CROMÁTICA TEAL

(*) 10x10	SOFT	[9,6x9,6x0,85 cm]	P183	V1	A	5	U4P4E3C2
30x30	SOFT	[29,6x29,6x0,85 cm]	P163	V1	A	5	U4P4E3C2
	POL	[29,6x29,6x0,80 cm]	P177	V1	A	3	U3P3E3C2
	SOFT	[29,6x59,2x0,85 cm]	P163	V1	A	5	U4P4E3C2
30x60	POL	[29,6x59,2x0,80 cm]	P177	V1	A	3	U3P3E3C2
	SOFT	[59,2x59,2x0,85 cm]	P163	V1	A	5	U4P4E3C2
	POL	[59,2x59,2x0,80 cm]	P177	V1	A	3	U3P3E3C2

CROMÁTICA TURQUESA

(*) 10x10	SOFT	[9,6x9,6x0,85 cm]	P237	V1	A	5	—	—	—	—	—	—	U4P4E3C2
30x30	MATT RECT	[29,6x29,6x0,85 cm]	P217	V1	A <td>5</td> <td>class 2</td> <td>A</td> <td>R10</td> <td>36*</td> <td>≥0,42</td> <td>U4P4E3C2</td>	5	class 2	A	R10	36*	≥0,42	U4P4E3C2	
	SOFT	[29,6x29,6x0,85 cm]	P217	V1	A <td>5</td> <td>—</td> <td>—</td> <td>—</td> <td>—</td> <td>—</td> <td>U4P4E3C2</td>	5	—	—	—	—	—	U4P4E3C2	
	POL	[29,6x29,6x0,80 cm]	P231	V1	A <td>3</td> <td>—</td> <td>—</td> <td>—</td> <td>—</td> <td>—</td> <td>U3P3E3C2</td>	3	—	—	—	—	—	U3P3E3C2	
30x60	MATT RECT	[29,6x59,2x0,85 cm]	P217	V1	A <td>5</td> <td>class 2</td> <td>A</td> <td>R10</td> <td>36*</td> <td>≥0,42</td> <td>U4P4E3C2</td>	5	class 2	A	R10	36*	≥0,42	U4P4E3C2	
	SOFT	[29,6x59,2x0,85 cm]	P217	V1	A <td>5</td> <td>—</td> <td>—</td> <td>—</td> <td>—</td> <td>—</td> <td>U4P4E3C2</td>	5	—	—	—	—	—	U4P4E3C2	
	POL	[29,6x59,2x0,80 cm]	P231	V1	A <td>3</td> <td>—</td> <td>—</td> <td>—</td> <td>—</td> <td>—</td> <td>U3P3E3C2</td>	3	—	—	—	—	—	U3P3E3C2	
60x60	MATT RECT	[59,2x59,2x0,85 cm]	P217	V1	A <td>5</td> <td>class 2</td> <td>A</td> <td>R10</td> <td>36*</td> <td>≥0,42</td> <td>U4P4E3C2</td>	5	class 2	A	R10	36*	≥0,42	U4P4E3C2	
	SOFT	[59,2x59,2x0,85 cm]	P217	V1	A <td>5</td> <td>—</td> <td>—</td> <td>—</td> <td>—</td> <td>—</td> <td>U4P4E3C2</td>	5	—	—	—	—	—	U4P4E3C2	
	POL	[59,2x59,2x0,80 cm]	P231	V1	A <td>3</td> <td>—</td> <td>—</td> <td>—</td> <td>—</td> <td>—</td> <td>U3P3E3C2</td>	3	—	—	—	—	—	U3P3E3C2	

(*) Peças produzidas de acordo com quantidades mínimas de 5m².
 (*) Pieces produced in minimum quantities of 5m².
 (*) Pièces produites selon des quantités minimales de 5m².
 (*) Piezas producidas en cantidades mínimas de 5m².



CROMÁTICA PISTACHIO

(*) 10x10	SOFT	[9,6x9,6x0,85 cm]	P183	V1	A	5	—	—	—	—	—	—	U4P4E3C2
30x30	MATT RECT	[29,6x29,6x0,85 cm]	P163	V1	A <td>5</td> <td>class 2</td> <td>A</td> <td>R10</td> <td>36*</td> <td>≥0,42</td> <td>U4P4E3C2</td>	5	class 2	A	R10	36*	≥0,42	U4P4E3C2	
	SOFT	[29,6x29,6x0,85 cm]	P163	V1	A <td>5</td> <td>—</td> <td>—</td> <td>—</td> <td>—</td> <td>—</td> <td>U4P4E3C2</td>	5	—	—	—	—	—	U4P4E3C2	
	POL	[29,6x29,6x0,80 cm]	P177	V1	A <td>3</td> <td>—</td> <td>—</td> <td>—</td> <td>—</td> <td>—</td> <td>U3P3E3C2</td>	3	—	—	—	—	—	U3P3E3C2	
30x60	MATT RECT	[29,6x59,2x0,85 cm]	P163	V1	A <td>5</td> <td>class 2</td> <td>A</td> <td>R10</td> <td>36*</td> <td>≥0,42</td> <td>U4P4E3C2</td>	5	class 2	A	R10	36*	≥0,42	U4P4E3C2	
	SOFT	[29,6x59,2x0,85 cm]	P163	V1	A <td>5</td> <td>—</td> <td>—</td> <td>—</td> <td>—</td> <td>—</td> <td>U4P4E3C2</td>	5	—	—	—	—	—	U4P4E3C2	
	POL	[29,6x59,2x0,80 cm]	P177	V1	A <td>3</td> <td>—</td> <td>—</td> <td>—</td> <td>—</td> <td>—</td> <td>U3P3E3C2</td>	3	—	—	—	—	—	U3P3E3C2	
60x60	MATT RECT	[59,2x59,2x0,85 cm]	P163	V1	A <td>5</td> <td>class 2</td> <td>A</td> <td>R10</td> <td>36*</td> <td>≥0,42</td> <td>U4P4E3C2</td>	5	class 2	A	R10	36*	≥0,42	U4P4E3C2	
	SOFT	[59,2x59,2x0,85 cm]	P163	V1	A <td>5</td> <td>—</td> <td>—</td> <td>—</td> <td>—</td> <td>—</td> <td>U4P4E3C2</td>	5	—	—	—	—	—	U4P4E3C2	
	POL	[59,2x59,2x0,80 cm]	P177	V1	A <td>3</td> <td>—</td> <td>—</td> <td>—</td> <td>—</td> <td>—</td> <td>U3P3E3C2</td>	3	—	—	—	—	—	U3P3E3C2	

CROMÁTICA OLIVA

(*) 10x10	SOFT	[9,6x9,6x0,85 cm]	P119	V1	A	5	—	—	—	—	—	—	U4P4E3C2
30x30	MATT RECT	[29,6x29,6x0,85 cm]	P99	V1	A <td>5</td> <td>class 2</td> <td>A</td> <td>R10</td> <td>36*</td> <td>≥0,42</td> <td>U4P4E3C2</td>	5	class 2	A	R10	36*	≥0,42	U4P4E3C2	
	SOFT	[29,6x29,6x0,85 cm]	P99	V1	A <td>5</td> <td>—</td> <td>—</td> <td>—</td> <td>—</td> <td>—</td> <td>U4P4E3C2</td>	5	—	—	—	—	—	U4P4E3C2	
	POL	[29,6x29,6x0,80 cm]	P113	V1	A <td>3</td> <td>—</td> <td>—</td> <td>—</td> <td>—</td> <td>—</td> <td>U3P3E3C2</td>	3	—	—	—	—	—	U3P3E3C2	
30x60	MATT RECT	[29,6x59,2x0,85 cm]	P99	V1	A <td>5</td> <td>class 2</td> <td>A</td> <td>R10</td> <td>36*</td> <td>≥0,42</td> <td>U4P4E3C2</td>	5	class 2	A	R10	36*	≥0,42	U4P4E3C2	
	SOFT	[29,6x59,2x0,85 cm]	P99	V1	A <td>5</td> <td>—</td> <td>—</td> <td>—</td> <td>—</td> <td>—</td> <td>U4P4E3C2</td>	5	—	—	—	—	—	U4P4E3C2	
	POL	[29,6x59,2x0,80 cm]	P113	V1	A <td>3</td> <td>—</td> <td>—</td> <td>—</td> <td>—</td> <td>—</td> <td>U3P3E3C2</td>	3	—	—	—	—	—	U3P3E3C2	
60x60	MATT RECT	[59,2x59,2x0,85 cm]	P99	V1	A <td>5</td> <td>class 2</td> <td>A</td> <td>R10</td> <td>36*</td> <td>≥0,42</td> <td>U4P4E3C2</td>	5	class 2	A	R10	36*	≥0,42	U4P4E3C2	
	SOFT	[59,2x59,2x0,85 cm]	P99	V1	A <td>5</td> <td>—</td> <td>—</td> <td>—</td> <td>—</td> <td>—</td> <td>U4P4E3C2</td>	5	—	—	—	—	—	U4P4E3C2	
	POL	[59,2x59,2x0,80 cm]	P113	V1	A <td>3</td> <td>—</td> <td>—</td> <td>—</td> <td>—</td> <td>—</td> <td>U3P3E3C2</td>	3	—	—	—	—	—	U3P3E3C2	

CROMÁTICA PALM

(*) 10x10	SOFT	[9,6x9,6x0,85 cm]	P183	V1	A	5	U4P4E3C2
30x30	SOFT	[29,6x29,6x0,85 cm]	P163	V1	A	5	U4P4E3C2
	POL	[29,6x29,6x0,80 cm]	P177	V1	A	3	U3P3E3C2
	SOFT	[29,6x59,2x0,85 cm]	P163	V1	A	5	U4P4E3C2
30x60	POL	[29,6x59,2x0,80 cm]	P177	V1	A	3	U3P3E3C2
	SOFT	[59,2x59,2x0,85 cm]	P163	V1	A	5	U4P4E3C2
	POL	[59,2x59,2x0,80 cm]	P177	V1	A	3	U3P3E3C2

CROMÁTICA CLOROFILA

(*) 10x10	SOFT	[9,6x9,6x0,85 cm]	P237	V1	A	5	—	—	—	—	—	—	U4P4E3C2
30x30	MATT RECT	[29,6x29,6x0,85 cm]	P217	V1	A <td>5</td> <td>class 2</td> <td>A</td> <td>R10</td> <td>36*</td> <td>≥0,42</td> <td>U4P4E3C2</td>	5	class 2	A	R10	36*	≥0,42	U4P4E3C2	
	SOFT	[29,6x29,6x0,85 cm]	P217	V1	A <td>5</td> <td>—</td> <td>—</td> <td>—</td> <td>—</td> <td>—</td> <td>U4P4E3C2</td>	5	—	—	—	—	—	U4P4E3C2	
	POL	[29,6x29,6x0,80 cm]	P231	V1	A <td>3</td> <td>—</td> <td>—</td> <td>—</td> <td>—</td> <td>—</td> <td>U3P3E3C2</td>	3	—	—	—	—	—	U3P3E3C2	
30x60	MATT RECT	[29,6x59,2x0,85 cm]	P217	V1	A <td>5</td> <td>class 2</td> <td>A</td> <td>R10</td> <td>36*</td> <td>≥0,42</td> <td>U4P4E3C2</td>	5	class 2	A	R10	36*	≥0,42	U4P4E3C2	
	SOFT	[29,6x59,2x0,85 cm]	P217	V1	A <td>5</td> <td>—</td> <td>—</td> <td>—</td> <td>—</td> <td>—</td> <td>U4P4E3C2</td>	5	—	—	—	—	—	U4P4E3C2	
	POL	[29,6x59,2x0,80 cm]	P231	V1	A <td>3</td> <td>—</td> <td>—</td> <td>—</td> <td>—</td> <td>—</td> <td>U3P3E3C2</td>	3	—	—	—	—	—	U3P3E3C2	
60x60	MATT RECT	[59,2x59,2x0,85 cm]	P217	V1	A <td>5</td> <td>class 2</td> <td>A</td> <td>R10</td> <td>36*</td> <td>≥0,42</td> <td>U4P4E3C2</td>	5	class 2	A	R10	36*	≥0,42	U4P4E3C2	
	SOFT	[59,2x59,2x0,85 cm]	P217	V1	A <td>5</td> <td>—</td> <td>—</td> <td>—</td> <td>—</td> <td>—</td> <td>U4P4E3C2</td>	5	—	—	—	—	—	U4P4E3C2	
	POL	[59,2x59,2x0,80 cm]	P231	V1	A <td>3</td> <td>—</td> <td>—</td> <td>—</td> <td>—</td> <td>—</td> <td>U3P3E3C2</td>	3	—	—	—	—	—	U3P3E3C2	

(*) Peças produzidas de acordo com quantidades mínimas de 5m².
 (*) Pieces produced in minimum quantities of 5m².
 (*) Pièces produites selon des quantités minimales de 5m².
 (*) Piezas producidas en cantidades mínimas de 5m².

Cromática _ Chromatic Remix & Cuts Chevron

Cromática _ Chromatic Remix & Cuts Half

Full body

Full body



CHEVRON LEFT CROMÁTICA ICE

10x30	SOFT	[9,6x29,6x0,90 cm]	P469
10x60	SOFT	[9,6x59,2x0,90 cm]	P395

CHEVRON LEFT CROMÁTICA SUPERBRANCO

10x30	SOFT	[9,6x29,6x0,85 cm]	P341
10x60	SOFT	[9,6x59,2x0,85 cm]	P289

CHEVRON LEFT CROMÁTICA BRANCO

10x30	SOFT	[9,6x29,6x0,85 cm]	P293
10x60	SOFT	[9,6x59,2x0,85 cm]	P249

CHEVRON LEFT CROMÁTICA QUARTZ

10x30	SOFT	[9,6x29,6x0,85 cm]	P293
10x60	SOFT	[9,6x59,2x0,85 cm]	P249

CHEVRON LEFT CROMÁTICA PLATINA

10x30	SOFT	[9,6x29,6x0,85 cm]	P293
10x60	SOFT	[9,6x59,2x0,85 cm]	P249

CHEVRON LEFT CROMÁTICA GRAFITE

10x30	SOFT	[9,6x29,6x0,85 cm]	P293
10x60	SOFT	[9,6x59,2x0,85 cm]	P249

CHEVRON LEFT CROMÁTICA ANTRACITE

10x30	SOFT	[9,6x29,6x0,85 cm]	P293
10x60	SOFT	[9,6x59,2x0,85 cm]	P249

CHEVRON LEFT CROMÁTICA PRETO

10x30	SOFT	[9,6x29,6x0,85 cm]	P293
10x60	SOFT	[9,6x59,2x0,85 cm]	P249

CHEVRON LEFT CROMÁTICA JET

10x30	SOFT	[9,6x29,6x0,85 cm]	P341
10x60	SOFT	[9,6x59,2x0,85 cm]	P289

CHEVRON RIGHT CROMÁTICA ICE

10x30	SOFT	[9,6x29,6x0,90 cm]	P469
10x60	SOFT	[9,6x59,2x0,90 cm]	P395

CHEVRON RIGHT CROMÁTICA SUPERBRANCO

10x30	SOFT	[9,6x29,6x0,85 cm]	P341
10x60	SOFT	[9,6x59,2x0,85 cm]	P289

CHEVRON RIGHT CROMÁTICA BRANCO

10x30	SOFT	[9,6x29,6x0,85 cm]	P293
10x60	SOFT	[9,6x59,2x0,85 cm]	P249

CHEVRON RIGHT CROMÁTICA QUARTZ

10x30	SOFT	[9,6x29,6x0,85 cm]	P293
10x60	SOFT	[9,6x59,2x0,85 cm]	P249

CHEVRON RIGHT CROMÁTICA PLATINA

10x30	SOFT	[9,6x29,6x0,85 cm]	P293
10x60	SOFT	[9,6x59,2x0,85 cm]	P249

CHEVRON RIGHT CROMÁTICA GRAFITE

10x30	SOFT	[9,6x29,6x0,85 cm]	P293
10x60	SOFT	[9,6x59,2x0,85 cm]	P249

CHEVRON RIGHT CROMÁTICA ANTRACITE

10x30	SOFT	[9,6x29,6x0,85 cm]	P293
10x60	SOFT	[9,6x59,2x0,85 cm]	P249

CHEVRON RIGHT CROMÁTICA PRETO

10x30	SOFT	[9,6x29,6x0,85 cm]	P293
10x60	SOFT	[9,6x59,2x0,85 cm]	P249

CHEVRON RIGHT CROMÁTICA JET

10x30	SOFT	[9,6x29,6x0,85 cm]	P341
10x60	SOFT	[9,6x59,2x0,85 cm]	P289

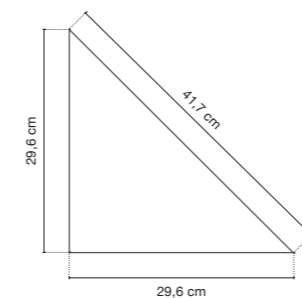

30x30x42 [29,6x29,6x41,7x0,85 cm]
[1m² = 21 peças_pieces]



HALF CROMÁTICA ARG PRATA
30x30x42 SOFT [29,6x29,6x41,7x0,85 cm] P197



HALF CROMÁTICA OCRE
30x30x42 SOFT [29,6x29,6x41,7x0,85 cm] P197



HALF CROMÁTICA BRANCO
30x30x42 SOFT [29,6x29,6x41,7x0,85 cm] P197



HALF CROMÁTICA GRAFITE
30x30x42 SOFT [29,6x29,6x41,7x0,85 cm] P197



HALF CROMÁTICA OLIVA
30x30x42 SOFT [29,6x29,6x41,7x0,85 cm] P197



HALF CROMÁTICA ALLOY
30x30x42 SOFT [29,6x29,6x41,7x0,85 cm] P243



HALF CROMÁTICA TEAL
30x30x42 SOFT [29,6x29,6x41,7x0,85 cm] P277



HALF CROMÁTICA MALVA
30x30x42 SOFT [29,6x29,6x41,7x0,85 cm] P243

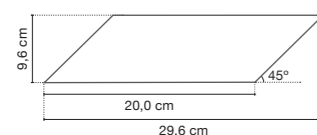

10x30 [9,6x29,6x0,85 cm]
[1m² = 52 peças_pieces]

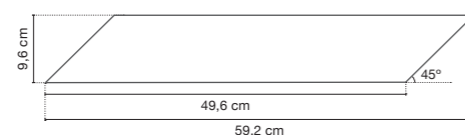

10x60 [9,6x59,2x0,85 cm]
[1m² = 21 peças_pieces]

Chevron: Peças produzidas de acordo com quantidades mínimas de 5m².
Chevron: Pieces produced in minimum quantities of 5m².
Chevron: Pièces produites selon des quantités minimales de 5m².
Chevron: Piezas producidas en cantidades mínimas de 5m².

Half: Peças produzidas de acordo com quantidades mínimas de 5m².
Half: Pieces produced in minimum quantities of 5m².
Half: Pièces produites selon des quantités minimales de 5m².
Half: Piezas producidas en cantidades mínimas de 5m².

Cromática _ Chromatic Remix & Cuts Trio

Target

Designer
Joana Ferreira

Full body

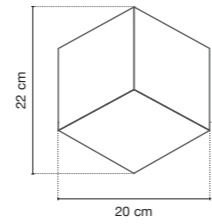

20x22 [...x0,85 cm]
[1m² = 32 peças_pieces]



TRIO COSY AUTUMN
Cromática: Lava + Branco + Luna
20x22x0,85 cm SOFT P18 /peça_piece



TRIO MOONLIGHT
Cromática: Antracite + Grafite + Alloy
20x22x0,85 cm SOFT P20 /peça_piece

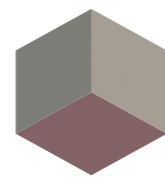

TRIO AURORA
Cromática: Grafite + Titanium + Malva
20x22x0,85 cm SOFT P20 /peça_piece



TRIO SPRING SPIRIT
Cromática: Citrus + Branco + Oliva
20x22x0,85 cm SOFT P20 /peça_piece

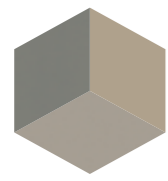

TRIO WINTER FALL
Cromática: Grafite + Luna + Titanium
20x22x0,85 cm SOFT P18 /peça_piece



TRIO STARRY SKY
Cromática: Antracite + Lava + Opala
20x22x0,85 cm SOFT P20 /peça_piece



TRIO DEEP OCEAN
Cromática: Teal + Bone + Jade
20x22x0,85 cm SOFT P22 /peça_piece



TRIO SUNSET BREEZE
Cromática: Ocre + Malva + Coral
20x22x0,85 cm SOFT P22 /peça_piece



CROMÁTICA CLOROFILA
30x30 MATT RECT [29,6x29,6x0,85 cm] P217

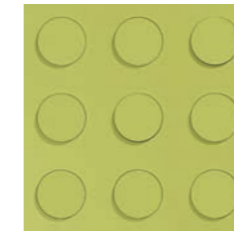

TARGET CLOROFILA
30x30 RECT [29,6x29,6x0,85 cm] P124 /peça_piece



CROMÁTICA COBALTO
30x30 MATT RECT [29,6x29,6x0,85 cm] P163



TARGET COBALTO
30x30 RECT [29,6x29,6x0,85 cm] P114 /peça_piece



CROMÁTICA SUPERBRANCO
30x30 MATT RECT [29,6x29,6x0,85 cm] P123



TARGET SUPERBRANCO
30x30 RECT [29,6x29,6x0,85 cm] P106 /peça_piece



Full body

Cromática Clorofila
Cromática Cobalto
Cromática Superbranco
Target

Centro Comercial Alegro Alfragide - Portugal _ Alegro Alfragide Shopping Center - Portugal

			Caixa Box			Europalette Europalet		
30x30 cm	Thickness (mm)	Cromática	Nº Peças No Pieces	M² Aprox. No of Sq. M. Approx.	Peso (Kg) Weight Kg	Nº Caixas No Boxes	M² Aprox. No of Sq. M. Approx.	Peso (Kg) Weight (Kg)
30x30 cm	8,5 ±5%	Cromática	10	0,9	18,0	64	57,60	1 173
30x30 cm	8,5 ±5%	Target	5	-	8,3	30	-	270

Cromática _ Chromatic Cross _ Linea _ Square

Cromática _ Chromatic

Full body



CROSS 8

30x30	MATT RECT	[29,6x29,6x0,85 cm]	P (base) + P75
	SOFT	[29,6x29,6x0,85 cm]	P (base) + P75
	POL	[29,6x29,6x0,80 cm]	P (base) + P75

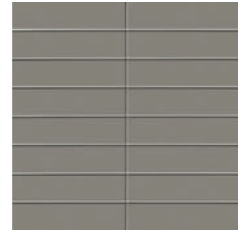

CROSS 16

30x30	MATT RECT	[29,6x29,6x0,85 cm]	P (base) + P81
	SOFT	[29,6x29,6x0,85 cm]	P (base) + P81
	POL	[29,6x29,6x0,80 cm]	P (base) + P81



CROSS 32

30x30	MATT RECT	[29,6x29,6x0,85 cm]	P (base) + P89
	SOFT	[29,6x29,6x0,85 cm]	P (base) + P89
	POL	[29,6x29,6x0,80 cm]	P (base) + P89



LINEA 2

30x30	MATT RECT	[29,6x29,6x0,85 cm]	P (base) + P63
	SOFT	[29,6x29,6x0,85 cm]	P (base) + P63
	POL	[29,6x29,6x0,80 cm]	P (base) + P63
30x60	MATT RECT	[29,6x59,2x0,85 cm]	P (base) + P68
	SOFT	[29,6x59,2x0,85 cm]	P (base) + P68
	POL	[29,6x59,2x0,80 cm]	P (base) + P68

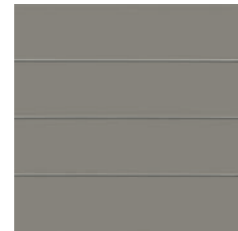

LINEA 4

30x30	MATT RECT	[29,6x29,6x0,85 cm]	P (base) + P67
	SOFT	[29,6x29,6x0,85 cm]	P (base) + P67
	POL	[29,6x29,6x0,80 cm]	P (base) + P67
30x60	MATT RECT	[29,6x59,2x0,85 cm]	P (base) + P72
	SOFT	[29,6x59,2x0,85 cm]	P (base) + P72
	POL	[29,6x59,2x0,80 cm]	P (base) + P72

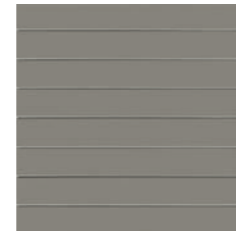

LINEA 8

30x30	MATT RECT	[29,6x29,6x0,85 cm]	P (base) + P73
	SOFT	[29,6x29,6x0,85 cm]	P (base) + P73
	POL	[29,6x29,6x0,80 cm]	P (base) + P73
30x60	MATT RECT	[29,6x59,2x0,85 cm]	P (base) + P78
	SOFT	[29,6x59,2x0,85 cm]	P (base) + P78
	POL	[29,6x59,2x0,80 cm]	P (base) + P78



SQUARE 4

30x30	MATT RECT	[29,6x29,6x0,85 cm]	P (base) + P73
	SOFT	[29,6x29,6x0,85 cm]	P (base) + P73
	POL	[29,6x29,6x0,80 cm]	P (base) + P73



SQUARE 16

30x30	MATT RECT	[29,6x29,6x0,85 cm]	P (base) + P77
	SOFT	[29,6x29,6x0,85 cm]	P (base) + P77
	POL	[29,6x29,6x0,80 cm]	P (base) + P77

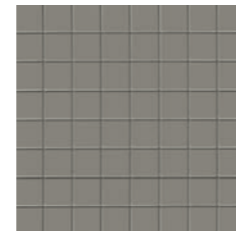

SQUARE 64

30x30	MATT RECT	[29,6x29,6x0,85 cm]	P (base) + P89
	SOFT	[29,6x29,6x0,85 cm]	P (base) + P89
	POL	[29,6x29,6x0,80 cm]	P (base) + P89

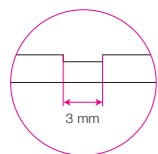

Estes efeitos – cross, linea e square – podem ser realizados, sob encomenda, para outras Coleções.
O cálculo do preço total de cada efeito por m² obtém-se, adicionando ao preço da base, o preço ("P") respetivo de cada efeito, ajustado ao escalão da Tabela de Grupos (P's).
Exemplo: o preço de Linea 2 Cromática Iron 30x30 cm Polido é: **P113+P63 = P139**.

The Linea, Cross and Square effects are available, upon order, for other collections.
The total price for each effect per m² is the sum of the base price plus the respective price ("P") for each effect, adjusted to the category of the Groups Price List (P's).
For example: the price for Linea 2 Cromática Iron 30x30 cm Polido is **P113+P63 = P139**.

Ces effets – cross, linea, square – peuvent être réalisés sur commande pour d'autres collections.
Le calcul du prix total de chaque effet au m² s'obtient en additionnant au prix de base, le prix ("P") de chaque effet, ajusté selon l'échelon du Tableau de Groupes (P's).
Exemple: Le prix de Linea 2 Cromática Iron 30x30 cm poli est le suivant: **P113+P63 = P139**.

Estos efectos – cross, linea y square – pueden realizarse en otras colecciones bajo petición.
El cálculo del precio total de cada efecto por m² se obtiene añadiendo al precio base el precio ("P") respectivo de cada efecto, según la Tabla de Grupos (P's).
Ejemplo: el precio de la Linea 2 Cromática Iron 30x30 cm Pulido sería: **P113+P63 = P139**.

Full body



Square 64 Cromática Anis
Square 64 Cromática Turquesa
Linea 8 Cromática Indigo

Design inclusivo para a melhoria da mobilidade, designadamente de pessoas invisuais e amblíopes.
Inclusive design for an improvement in mobility, namely of people who are blind or partially sighted.
Design inclusif pour l'amélioration de la mobilité, notamment celle des personnes aveugles et amblyopes.
Diseño inclusivo para una mayor movilidad, especialmente a personas invidentes o con deficiencias visuales.

Táteis _ Tactile

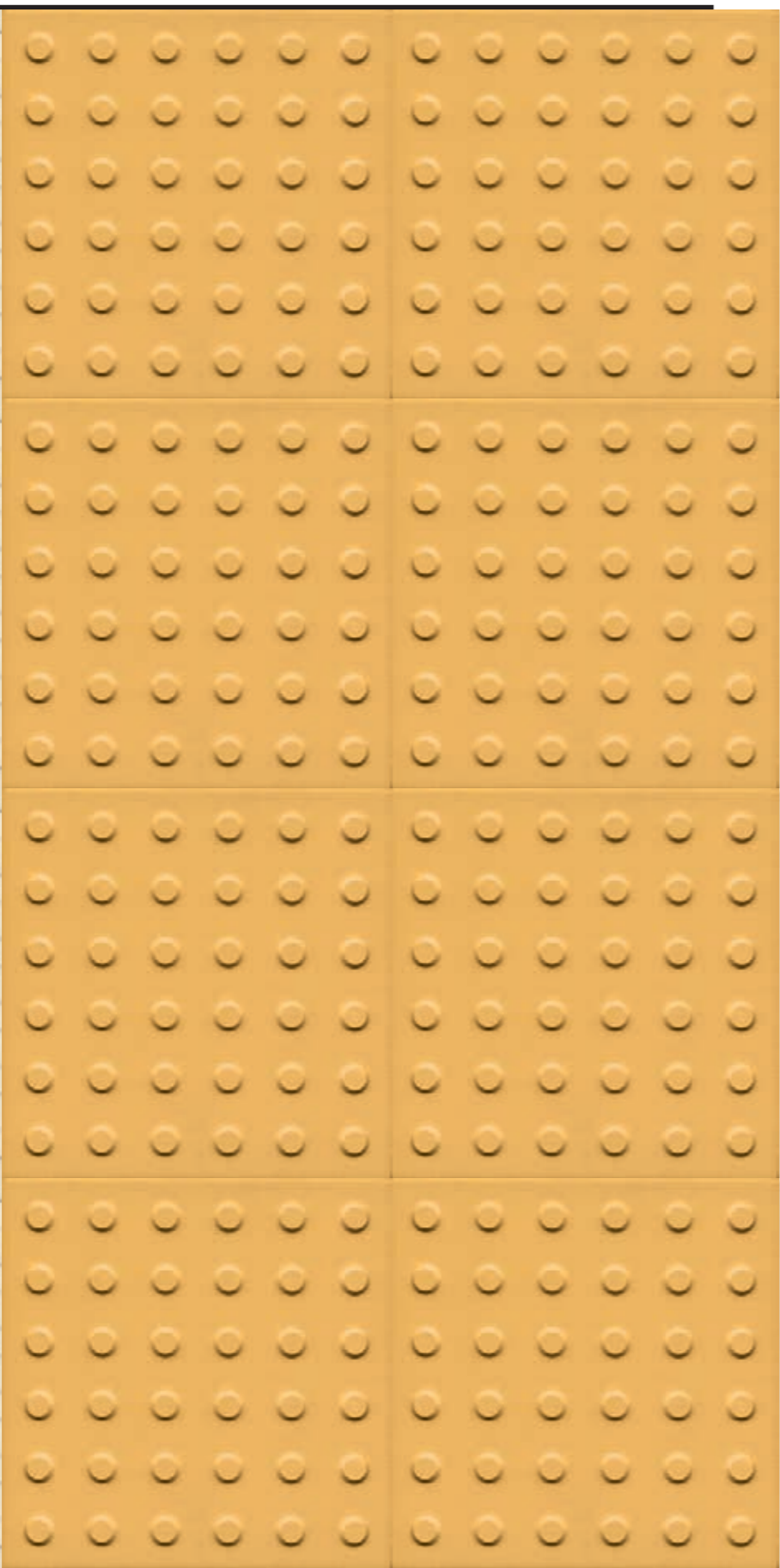
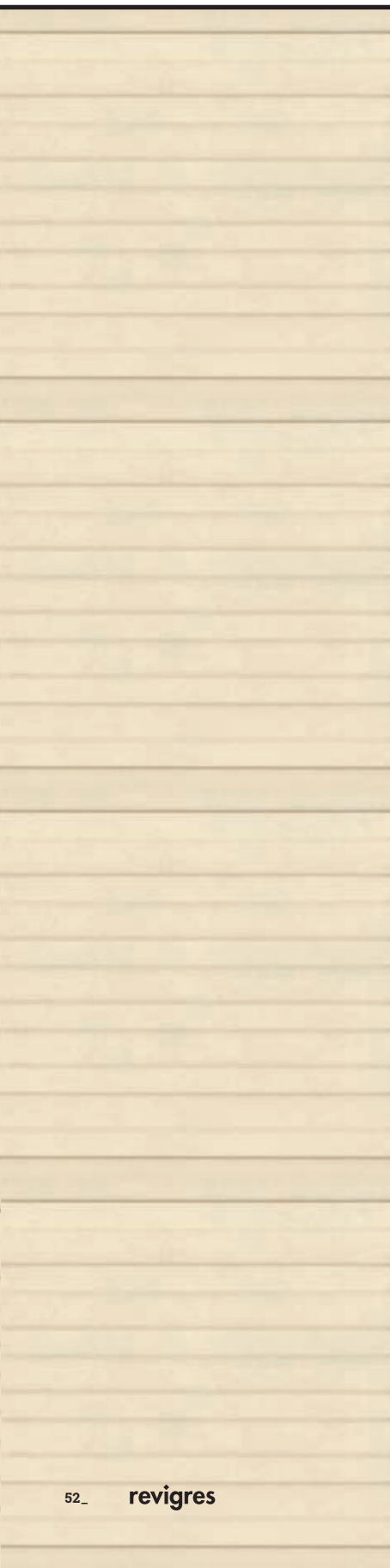

Cautela
Segurança
Estação De Metro "Plaza Elíptica" - Madrid, Espanha
Plaza Elíptica - Underground Station - Madrid, Spain

- 02** cores
colors
couleurs
colores
- 01** formato
format
format
formato
- 01** acabamento
finish
 finition
 acabado



Design inclusivo

Inclusive design

Design inclusif

Diseño inclusivo

Norma _ Standard _ Norme _ Norma

**ISO/TC 173
UNE 12 70 29**

Sistema técnico e auxiliar que respeita normas de acessibilidades.
Auxiliary technical system that respects accessibility norms.
Système technique et auxiliaire qui respecte les normes d'accessibilités.
Sistema técnico y auxiliar que respeta las normativas de accesibilidad.

Guia



29x29 (11"x11")
[29,0x29,0 cm]

RECT \pm 1,45 cm

Segurança

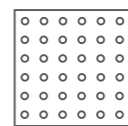

29x29 (11"x11")
[29,0x29,0 cm]

RECT \pm 1,45 cm

Os pavimentos táteis foram especialmente desenvolvidos pela Revigrés, de acordo com o Sistema Técnico e Auxiliar que respeita normas de acessibilidades, para facilitar a orientação e aumentar a segurança dos utilizadores. Com os pavimentos táteis é possível transmitir informações – através do contraste de cores e do relevo das superfícies – sobre mudanças de direção, proximidade de situações que exigem maior cautela e áreas seguras. Os pavimentos táteis asseguram uma melhoria da mobilidade em geral, designadamente das pessoas invisuais e amblíopes.

Tactile floors were especially developed by Revigrés in accordance with the Auxiliary and Technical System which respects accessibility standards to facilitate orientation and increase the safety of users. With tactile floors it is possible to transmit information – by contrasting colours and the relief of surfaces – about changes in direction, the proximity of situations requiring greater care and safe areas. Tactile floors ensure an improvement in general mobility, namely of people who are blind or partially sighted.

Les sols tactiles ont spécialement été développés par Revigrés, conformément aux Système Technique et Auxiliaire respectant les normes d'accessibilités, afin de faciliter l'orientation et d'augmenter la sécurité des utilisateurs. Avec les sols tactiles, il est possible de transmettre des informations – grâce au contraste de couleurs et au relief des surfaces – quant aux changements de direction, à la proximité de situations exigeant une plus grande prudence – et des zones sécurisées. Les sols tactiles assurent une amélioration de la mobilité en général, notamment celle des personnes aveugles et amblyopes.

Los pavimentos táctiles han sido especialmente desarrollados por Revigrés, de acuerdo con el Sistema Técnico y Auxiliar, respetando las normas sobre accesibilidad con el fin de facilitar la orientación y aumentar la seguridad de los usuarios. A través del contraste de los colores y del relieve de las superficies, los pavimentos táctiles permiten transmitir información sobre cambios de dirección, proximidad de situaciones que exigen una mayor atención, además de áreas seguras.

Los pavimentos táctiles permiten una mayor movilidad en general, especialmente en personas invidentes o con deficiencias visuales.

Cautela

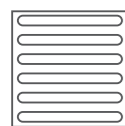

29x29 (11"x11")
[29,0x29,0 cm]

RECT \pm 1,45 cm

Mudança de direção



29x29 (11"x11")
[29,0x29,0 cm]

RECT \pm 1,45 cm



Peças / Pieces		Caixa / Box			Europaleta / Europallet		
Espeçura (mm) Thickness (mm)	Nº Peças No Pieces	M² Aprox. No of Sq. M. Approx.	Peso (Kg) Weight Kg	Nº Caixas No Boxes	M² Aprox. No of Sq. M. Approx.	Peso (Kg) Weight (Kg)	
29x29 cm Rect.	\pm 14,5 \pm 0,5 mm	7	0,59	17	50	29,5	871

GUIA BRANCO

29x29 RECT [29,0x29,0x1,45 cm] **P109** V1



SEGURANÇA AMARELO

29x29 RECT [29,0x29,0x1,45 cm] **P109** V1

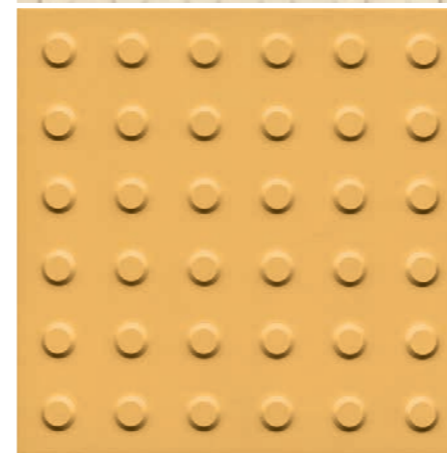

CAUTELA BRANCO

29x29 RECT [29,0x29,0x1,45 cm] **P109** V1



MUDANÇA DE DIREÇÃO BRANCO

29x29 RECT [29,0x29,0x1,45 cm] **P109** V1

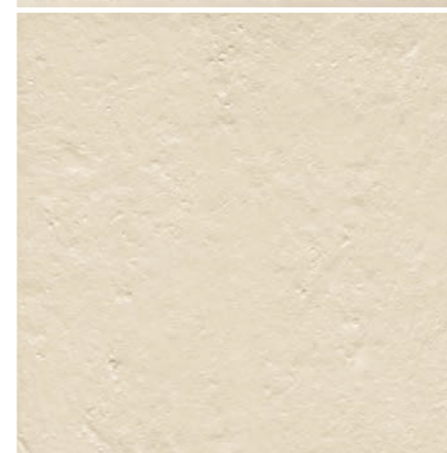

Estas peças são produzidas de acordo com quantidades mínimas exigidas.
These pieces are produced according to minimum quantities requirements.
La fabrication de ces pièces est soumise à des quantités minimales.
Estas piezas se producen de acuerdo con las cantidades mínimas exigidas.

A versatilidade e elevada durabilidade do grés porcelânico toda a massa.
The versatility and high durability of full-body porcelain tiles.
La versatilité et la haute durabilité du grés cérame pleine masse.
La versatilidad y elevada durabilidad del gres porcelánico todo masa.

Flint



Flint Glaciar
Flint Glaciar Estruturado / Structured



Flint Marfim
Flint Marfim Estruturado / Structured

08 cores
couleurs
colores

08 formatos
formats
formatos

04 acabamentos
finishes
finitions
acabados



60x120 (24"x47")
[59,2x118,4 cm]

RECT ± 0,98 cm
SOFT ± 0,98 cm
POL ± 0,93 cm



60x60 (24"x24")
[59,2x59,2 cm]

RECT ± 0,85 cm
SOFT ± 0,85 cm
POL ± 0,80 cm
ESTR ± 0,85 cm



30x60 (12"x24")
[29,6x59,2 cm]

RECT ± 0,85 cm
SOFT ± 0,85 cm
POL ± 0,80 cm
ESTR ± 0,85 cm



15x60 (6"x24")
[14,7x59,2 cm]

RECT ± 0,85 cm
SOFT ± 0,85 cm

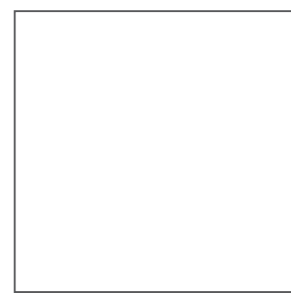

90x90 (35"x35")
[89,0x89,0 cm]

RECT ± 1,05 cm
SOFT ± 1,05 cm
POL ± 0,98 cm



45x90 (18"x35")
[44,5x89,0 cm]

RECT ± 1,05 cm
SOFT ± 1,05 cm
POL ± 0,98 cm



45x45 (18"x18")
[44,4x44,4 cm]

RECT ± 0,82 cm
SOFT ± 0,82 cm
POL ± 0,77 cm

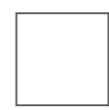

30x30 (12"x12")
[29,6x29,6 cm]

RECT ± 0,85 cm
SOFT ± 0,85 cm
POL ± 0,80 cm

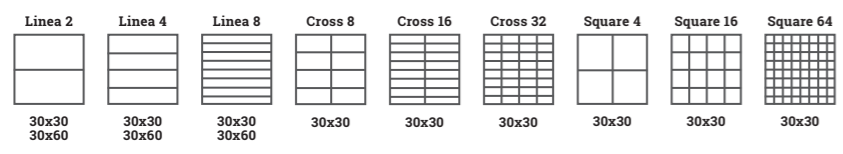

Pág. 50

	Peças / Pieces			Caixa / Box			Europaleta / Europallet		
	Formato	Espeçura (mm) / Thickness (mm)	Nº Peças / No Pieces	M² Aprox. / No of Sq. M. Approx.	Peso (Kg) / Weight Kg	Nº Caixas / No Boxes	M² Aprox. / No of Sq. M. Approx.	Peso (Kg) / Weight (Kg)	
30x30 cm	Rect. / Soft	± 8,5 ±5%	10	0.90	18.0	64	57.60	1 173	
	Pol.	± 8,0 ±5%	10	0.90	16.0	64	57.60	1 045	
15x60 cm	Rect. / Soft	± 8,5 ±5%	10	0.90	19.0	64	57.60	1 237	
30x60 cm	Rect. / Soft	± 8,5 ±5%	5	0.90	18.0	60	54.00	1 101	
	Pol.	± 8,0 ±5%	5	0.90	16.0	60	54.00	981	
60x60 cm	Rect. / Soft	± 8,5 ±5%	4	1.44	28.7	36	51.84	1 053	
	Pol.	± 8,0 ±5%	4	1.44	26.7	36	51.84	981	
60x120 cm	Rect. / Soft	± 9,8 ±5%	2	1.44	33.0	30	43.20	1 011	
	Pol.	± 9,3 ±5%	2	1.44	31.0	30	43.20	951	
45x45 cm	Rect. / Soft	± 8,2 ±5%	6	1.22	24.0	34	41.48	837	
	Pol.	± 7,7 ±5%	6	1.22	21.6	34	41.48	755	
45x90 cm	Rect. / Soft	± 10,5 ±0,5 mm	4	1.62	39.0	27	43.74	1 074	
	Pol.	± 9,8 ±5%	4	1.62	37.0	27	43.74	1 020	
90x90 cm	Rect. / Soft	± 10,5 ±0,5 mm	2	1.62	39.0	24	38.88	991	
	Pol.	± 9,8 ±5%	2	1.62	37.0	24	38.88	943	

De modo a proteger a superfície das peças, os produtos no acabamento polido têm uma fina camada de impermeabilizante, que apenas deve ser removida após a conclusão da obra.
 Tiles with polished finish are protected with waterproof coating that must be removed only after the works are concluded.
 En vue de protéger la surface des pièces, les produits à la finition polie ont une fine couche d'imperméabilisant qui ne devrait être éliminée qu'après l'achèvement des travaux.
 Con el fin de proteger la superficie de las piezas, los productos con acabado pulido tienen una fina capa de impermeabilizante, que solo debe eliminarse una vez terminado el trabajo.

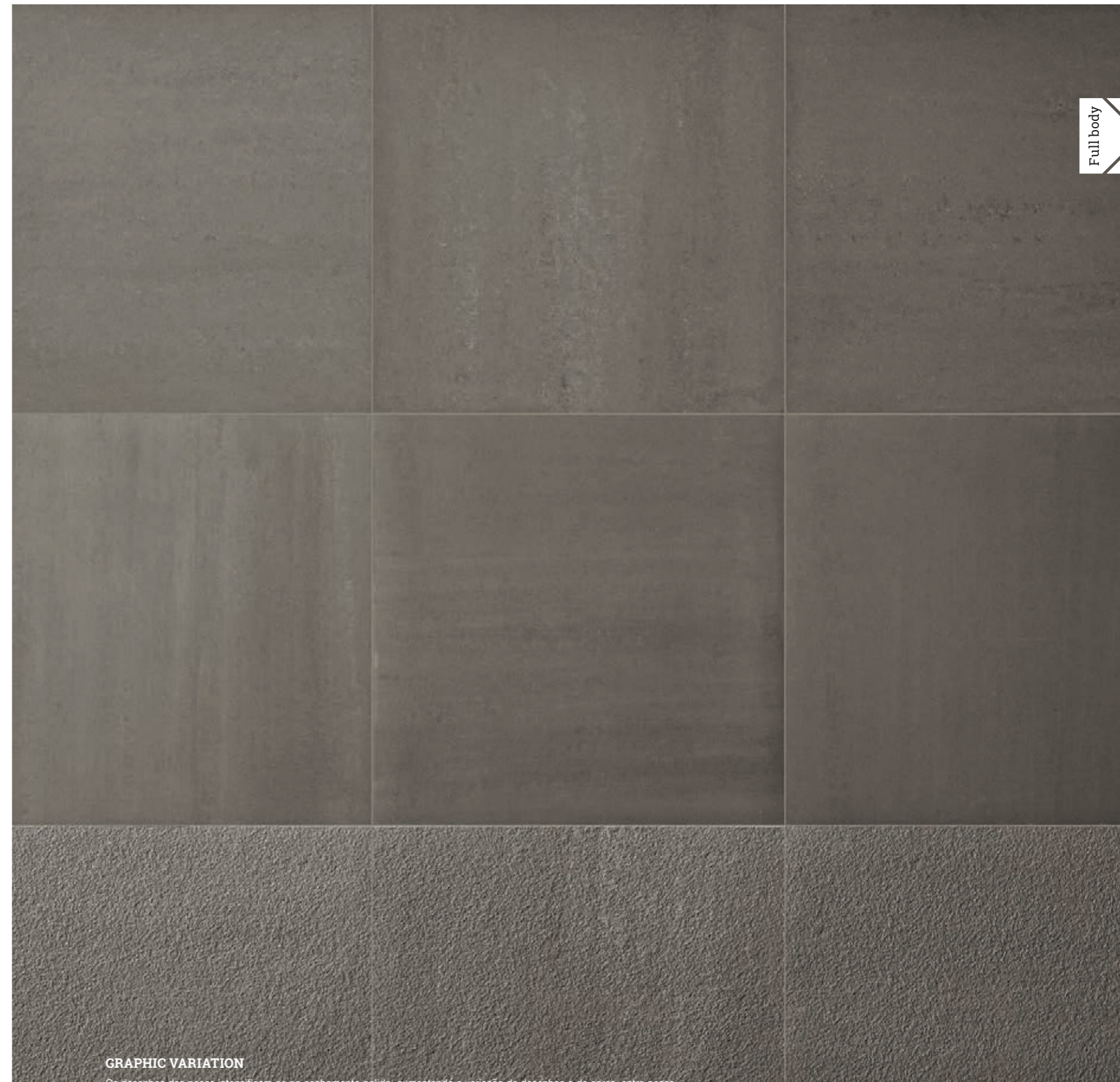

GRAPHIC VARIATION

Os desenhos das peças intensificam-se no acabamento polido, aumentando a variação de desenhos e de cores, entre peças.
 The designs of the pieces are more intense in the polished finish, enhancing design and colour variation across pieces.
 Les dessins des pièces s'intensifient avec la finition polie, augmentant la variation des dessins et des couleurs entre les pièces.
 Los diseños de las piezas se intensifican con el acabado pulido, aumentando la variación de diseños y colores entre las piezas.

Flint

08

cores
colors
couleurs
colores

08

formatos
formats
formats
formatos

04

acabamentos
finishes
finitions
acabados

Full body

Rect	Flint Marfim	Flint Platina	Flint Arg Prata	Flint Ice
Soft	Flint Marfim	Flint Platina	Flint Arg Prata	Flint Ice
Pol	Flint Marfim	Flint Platina	Flint Arg Prata	Flint Ice
Estr	Flint Marfim	Flint Platina	Flint Arg Prata	Flint Ice

Flint

Rect	Flint Glaciar	Flint Fog	Flint Gris	Flint Preto
Soft	Flint Glaciar	Flint Fog	Flint Gris	Flint Preto
Pol	Flint Glaciar	Flint Fog	Flint Gris	Flint Preto
Estr	Flint Glaciar	Flint Fog	Flint Gris	Flint Preto

Full body



FLINT MARFIM

Size	Shape	Dimensions	Code	Material	Class	Area	Weight	Thickness	Surface
30x30	RECT	[29,6x29,6x0,85 cm]	P95	V2	A	class 2	A	R10	36* ≥0,42
	SOFT	[29,6x29,6x0,85 cm]	P95	V2	A	class 2	A	R10	36* ≥0,42
	POL	[29,6x29,6x0,80 cm]	P109	V3	A	class 2	A	R10	36* ≥0,42
15x60	RECT	[14,7x59,2x0,85 cm]	P101	V2	A	class 2	A	R10	36* ≥0,42
	SOFT	[14,7x59,2x0,85 cm]	P101	V2	A	class 2	A	R10	36* ≥0,42
30x60	RECT	[29,6x59,2x0,85 cm]	P91	V2	A	class 2	A	R10	36* ≥0,42
	SOFT	[29,6x59,2x0,85 cm]	P91	V2	A	class 2	A	R10	36* ≥0,42
	POL	[29,6x59,2x0,80 cm]	P105	V3	A	class 2	A	R10	36* ≥0,42
60x60	RECT	[59,2x59,2x0,85 cm]	P101	V2	A	class 2	A	R10	36* ≥0,42
	SOFT	[59,2x59,2x0,85 cm]	P101	V2	A	class 2	A	R10	36* ≥0,42
	POL	[59,2x59,2x0,80 cm]	P115	V3	A	class 2	A	R10	36* ≥0,42
60x120	RECT	[59,2x118,4x0,98 cm]	P133	V2	A	class 2	A	R10	36* ≥0,42
	SOFT	[59,2x118,4x0,98 cm]	P133	V2	A	class 2	A	R10	36* ≥0,42
	POL	[59,2x118,4x0,93 cm]	P153	V3	A	class 2	A	R10	36* ≥0,42
45x45	RECT	[44,4x44,4x0,82 cm]	P91	V2	A	class 2	A	R10	36* ≥0,42
	SOFT	[44,4x44,4x0,82 cm]	P91	V2	A	class 2	A	R10	36* ≥0,42
	POL	[44,4x44,4x0,77 cm]	P105	V3	A	class 2	A	R10	36* ≥0,42
45x90	RECT	[44,5x89,0x1,05 cm]	P129	V2	A	class 2	A	R10	36* ≥0,42
	SOFT	[44,5x89,0x1,05 cm]	P129	V2	A	class 2	A	R10	36* ≥0,42
	POL	[44,5x89,0x0,98 cm]	P149	V3	A	class 2	A	R10	36* ≥0,42
90x90	RECT	[89,0x89,0x1,05 cm]	P129	V2	A	class 2	A	R10	36* ≥0,42
	SOFT	[89,0x89,0x1,05 cm]	P129	V2	A	class 2	A	R10	36* ≥0,42
	POL	[89,0x89,0x0,98 cm]	P149	V3	A	class 2	A	R10	36* ≥0,42

FLINT MARFIM ESTRUTURADO _ STRUCTURED

30x60	RECT	[29,6x59,2x0,85 cm]	P91	V2	A	class 3	B	R11	36* ≥0,42	U4P3E3C2
60x60	RECT	[59,2x59,2x0,85 cm]	P101	V2	A	class 3	B	R11	36* ≥0,42	U4P4E3C2

FLINT 3D MARFIM

60x120	RECT	[59,2x118,4x0,98 cm]	P143	V2						
--------	------	----------------------	------	----	--	--	--	--	--	--

Estruturado _ Structured: Produtos que minimizam o risco de deslizamento.
 Estruturado _ Structured: Products that minimize the risk of slipping.
 Estruturado _ Structured: Produits qui réduisent le risque de glissement.
 Estruturado _ Structured: Productos que minimizan el riesgo de deslizamiento.

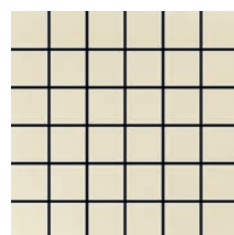

STRATUS 36
 FLINT MARFIM (a) (f)
 30x30 P19/peça_pieza

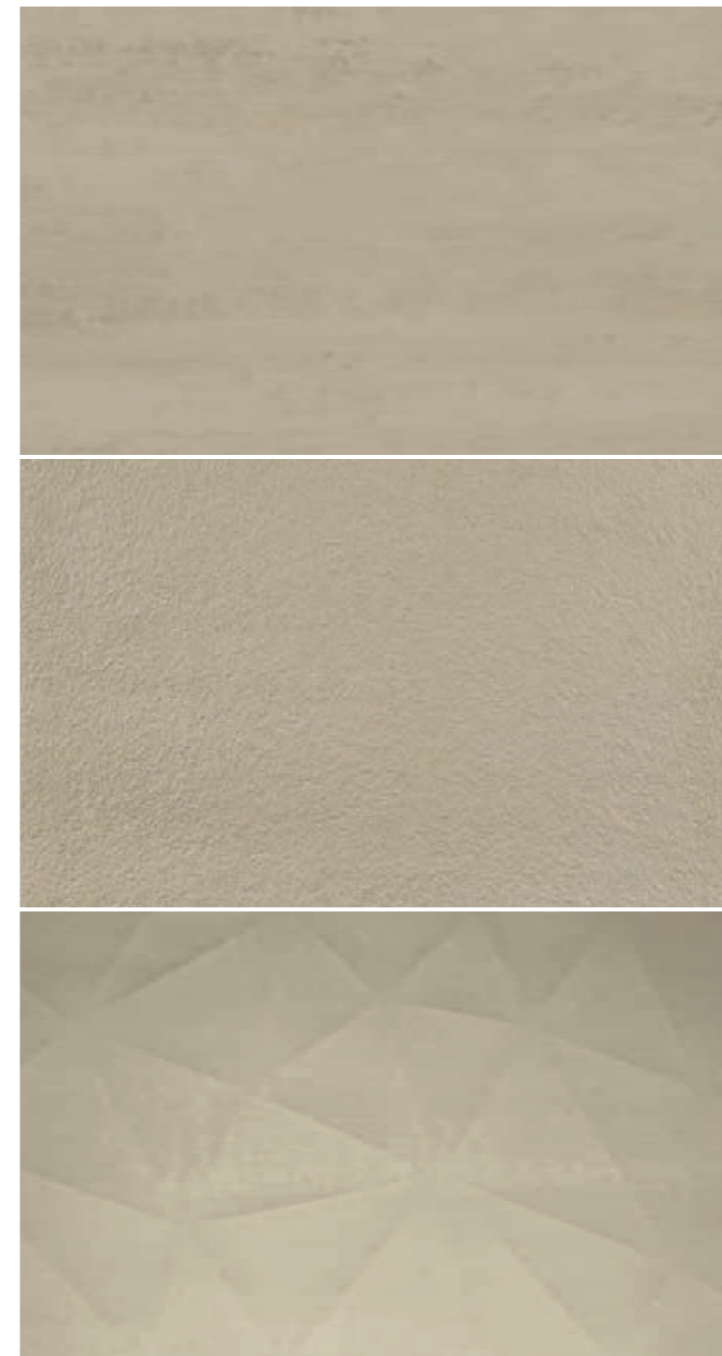

FLINT PLATINA

Size	Shape	Dimensions	Code	Material	Class	Area	Weight	Thickness	Surface
30x30	RECT	[29,6x29,6x0,85 cm]	P89	V2	A	class 2	A	R10	36* ≥0,42
	SOFT	[29,6x29,6x0,85 cm]	P89	V2	A	class 2	A	R10	36* ≥0,42
	POL	[29,6x29,6x0,80 cm]	P103	V3	A	class 2	A	R10	36* ≥0,42
15x60	RECT	[14,7x59,2x0,85 cm]	P95	V2	A	class 2	A	R10	36* ≥0,42
	SOFT	[14,7x59,2x0,85 cm]	P95	V2	A	class 2	A	R10	36* ≥0,42
30x60	RECT	[29,6x59,2x0,85 cm]	P85	V2	A	class 2	A	R10	36* ≥0,42
	SOFT	[29,6x59,2x0,85 cm]	P85	V2	A	class 2	A	R10	36* ≥0,42
	POL	[29,6x59,2x0,80 cm]	P99	V3	A	class 2	A	R10	36* ≥0,42
60x60	RECT	[59,2x59,2x0,85 cm]	P95	V2	A	class 2	A	R10	36* ≥0,42
	SOFT	[59,2x59,2x0,85 cm]	P95	V2	A	class 2	A	R10	36* ≥0,42
	POL	[59,2x59,2x0,80 cm]	P109	V3	A	class 2	A	R10	36* ≥0,42
60x120	RECT	[59,2x118,4x0,98 cm]	P127	V2	A	class 2	A	R10	36* ≥0,42
	SOFT	[59,2x118,4x0,98 cm]	P127	V2	A	class 2	A	R10	36* ≥0,42
	POL	[59,2x118,4x0,93 cm]	P147	V3	A	class 2	A	R10	36* ≥0,42
45x45	RECT	[44,4x44,4x0,82 cm]	P85	V2	A	class 2	A	R10	36* ≥0,42
	SOFT	[44,4x44,4x0,82 cm]	P85	V2	A	class 2	A	R10	36* ≥0,42
	POL	[44,4x44,4x0,77 cm]	P99	V3	A	class 2	A	R10	36* ≥0,42
45x90	RECT	[44,5x89,0x1,05 cm]	P123	V2	A	class 2	A	R10	36* ≥0,42
	SOFT	[44,5x89,0x1,05 cm]	P123	V2	A	class 2	A	R10	36* ≥0,42
	POL	[44,5x89,0x0,98 cm]	P143	V3	A	class 2	A	R10	36* ≥0,42
90x90	RECT	[89,0x89,0x1,05 cm]	P123	V2	A	class 2	A	R10	36* ≥0,42
	SOFT	[89,0x89,0x1,05 cm]	P123	V2	A	class 2	A	R10	36* ≥0,42
	POL	[89,0x89,0x0,98 cm]	P143	V3	A	class 2	A	R10	36* ≥0,42

FLINT PLATINA ESTRUTURADO _ STRUCTURED

30x60	RECT	[29,6x59,2x0,85 cm]	P85	V2	A	class 3	B	R11	36* ≥0,42	U4P3E3C2
60x60	RECT	[59,2x59,2x0,85 cm]	P95	V2	A	class 3	B	R11	36* ≥0,42	U4P4E3C2

FLINT 3D PLATINA

60x120	RECT	[59,2x118,4x0,98 cm]	P137	V2						
--------	------	----------------------	------	----	--	--	--	--	--	--

Estruturado _ Structured: Produtos que minimizam o risco de deslizamento.
 Estruturado _ Structured: Products that minimize the risk of slipping.
 Estruturado _ Structured: Produits qui réduisent le risque de glissement.
 Estruturado _ Structured: Productos que minimizan el riesgo de deslizamiento.

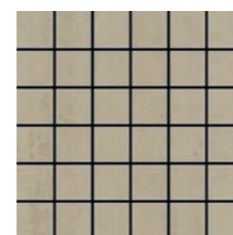

STRATUS 36
 FLINT PLATINA (a) (f)
 30x30 P19/peça_pieza



FLINT ARG PRATA

30x30	RECT	[29,6x29,6x0,85 cm]	P89	V2	5	class 2	A	R10	36*	≥0,42	U4P4E3C2
	SOFT	[29,6x29,6x0,85 cm]	P89	V2	5						
	POL	[29,6x29,6x0,80 cm]	P103	V3	3						U3P3E3C2
15x60	RECT	[14,7x59,2x0,85 cm]	P95	V2	5	class 2	A	R10	36*	≥0,42	
	SOFT	[14,7x59,2x0,85 cm]	P95	V2	5						
30x60	RECT	[29,6x59,2x0,85 cm]	P85	V2	5	class 2	A	R10	36*	≥0,42	U4P4E3C2
	SOFT	[29,6x59,2x0,85 cm]	P85	V2	5						
	POL	[29,6x59,2x0,80 cm]	P99	V3	3						U3P3E3C2
60x60	RECT	[59,2x59,2x0,85 cm]	P95	V2	5	class 2	A	R10	36*	≥0,42	U4P4E3C2
	SOFT	[59,2x59,2x0,85 cm]	P95	V2	5						
	POL	[59,2x59,2x0,80 cm]	P109	V3	3						U3P3E3C2
60x120	RECT	[59,2x118,4x0,98 cm]	P127	V2	5	class 2	A	R10	36*	≥0,42	U4P4E3C2
	SOFT	[59,2x118,4x0,98 cm]	P127	V2	5						
	POL	[59,2x118,4x0,93 cm]	P147	V3	3						U3P3E3C2
45x45	RECT	[44,4x44,4x0,82 cm]	P85	V2	5	class 2	A	R10	36*	≥0,42	U4P4E3C2
	SOFT	[44,4x44,4x0,82 cm]	P85	V2	5						
	POL	[44,4x44,4x0,77 cm]	P99	V3	3						U3P3E3C2
45x90	RECT	[44,5x89,0x1,05 cm]	P123	V2	5	class 2	A	R10	36*	≥0,42	U4P4E3C2
	SOFT	[44,5x89,0x1,05 cm]	P123	V2	5						
	POL	[44,5x89,0x0,98 cm]	P143	V3	3						U3P3E3C2
90x90	RECT	[89,0x89,0x1,05 cm]	P123	V2	5	class 2	A	R10	36*	≥0,42	U4P4E3C2
	SOFT	[89,0x89,0x1,05 cm]	P123	V2	5						
	POL	[89,0x89,0x0,98 cm]	P143	V3	3						U3P3E3C2

FLINT ARG PRATA ESTRUTURADO _ STRUCTURED

30x60	RECT	[29,6x59,2x0,85 cm]	P85	V2	5	class 3	B	R11	36*	≥0,42	U4P4E3C2
60x60	RECT	[59,2x59,2x0,85 cm]	P95	V2	5	class 3	B	R11	36*	≥0,42	U4P4E3C2

FLINT 3D ARG PRATA

60x120	RECT	[59,2x118,4x0,98 cm]	P137	V2							
--------	------	----------------------	------	----	--	--	--	--	--	--	--

Estruturado _ Structured: Produtos que minimizam o risco de deslizamento.
Estruturado _ Structured: Products that minimize the risk of slipping.
Estruturado _ Structured: Produits qui réduisent le risque de glissement.
Estruturado _ Structured: Productos que minimizan el riesgo de deslizamiento.



STRATUS 36
FLINT ARG PRATA (a) (f)
30x30 P19/peça_pieza



FLINT ICE

30x30	RECT	[29,6x29,6x0,85 cm]	P99	V2	5	class 2	A	R10	36*	≥0,42	U4P4E3C2
	SOFT	[29,6x29,6x0,85 cm]	P99	V2	5						
	POL	[29,6x29,6x0,80 cm]	P113	V3	3						U3P3E3C2
15x60	RECT	[14,7x59,2x0,85 cm]	P105	V2	5	class 2	A	R10	36*	≥0,42	
	SOFT	[14,7x59,2x0,85 cm]	P105	V2	5						
30x60	RECT	[29,6x59,2x0,85 cm]	P95	V2	5	class 2	A	R10	36*	≥0,42	U4P4E3C2
	SOFT	[29,6x59,2x0,85 cm]	P95	V2	5						
	POL	[29,6x59,2x0,80 cm]	P109	V3	3						U3P3E3C2
60x60	RECT	[59,2x59,2x0,85 cm]	P105	V2	5	class 2	A	R10	36*	≥0,42	U4P4E3C2
	SOFT	[59,2x59,2x0,85 cm]	P105	V2	5						
	POL	[59,2x59,2x0,80 cm]	P119	V3	3						U3P3E3C2
60x120	RECT	[59,2x118,4x0,98 cm]	P137	V2	5	class 2	A	R10	36*	≥0,42	
	SOFT	[59,2x118,4x0,98 cm]	P137	V2	5						
	POL	[59,2x118,4x0,93 cm]	P157	V3	3						
45x45	RECT	[44,4x44,4x0,82 cm]	P95	V2	5	class 2	A	R10	36*	≥0,42	U4P4E3C2
	SOFT	[44,4x44,4x0,82 cm]	P95	V2	5						
	POL	[44,4x44,4x0,77 cm]	P109	V3	3						U3P3E3C2
45x90	RECT	[44,5x89,0x1,05 cm]	P133	V2	5	class 2	A	R10	36*	≥0,42	
	SOFT	[44,5x89,0x1,05 cm]	P133	V2	5						
	POL	[44,5x89,0x0,98 cm]	P153	V3	3						
90x90	RECT	[89,0x89,0x1,05 cm]	P133	V2	5	class 2	A	R10	36*	≥0,42	
	SOFT	[89,0x89,0x1,05 cm]	P133	V2	5						
	POL	[89,0x89,0x0,98 cm]	P153	V3	3						

FLINT ICE ESTRUTURADO _ STRUCTURED

30x60	RECT	[29,6x59,2x0,85 cm]	P95	V2	5	class 3	B	R11	36*	≥0,42	U4P4E3C2
60x60	RECT	[59,2x59,2x0,85 cm]	P105	V2	5	class 3	B	R11	36*	≥0,42	U4P4E3C2

FLINT 3D ICE

60x120	RECT	[59,2x118,4x0,98 cm]	P147	V2							
--------	------	----------------------	------	----	--	--	--	--	--	--	--

Estruturado _ Structured: Produtos que minimizam o risco de deslizamento.
Estruturado _ Structured: Products that minimize the risk of slipping.
Estruturado _ Structured: Produits qui réduisent le risque de glissement.
Estruturado _ Structured: Productos que minimizan el riesgo de deslizamiento.

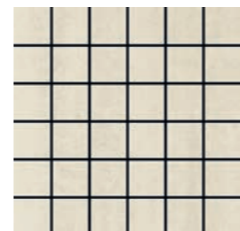

STRATUS 36
FLINT ICE (a) (f)
30x30 P19/peça_pieza

Full body



FLINT GLACIAR

Size	Finish	Dimensions	Product Code	Profile	Height	Class	Grade	Water Absorption	Wear Resistance
30x30	RECT	[29,6x29,6x0,85 cm]	P99	V2	5	class 2	A	R10	36+ ≥0,42
	SOFT	[29,6x29,6x0,85 cm]	P99	V2	5	—	—	—	—
	POL	[29,6x29,6x0,80 cm]	P113	V3	3	—	—	—	U3P3E3C2
15x60	RECT	[14,7x59,2x0,85 cm]	P105	V2	5	class 2	A	R10	36+ ≥0,42
	SOFT	[14,7x59,2x0,85 cm]	P105	V2	5	—	—	—	—
30x60	RECT	[29,6x59,2x0,85 cm]	P95	V2	5	class 2	A	R10	36+ ≥0,42
	SOFT	[29,6x59,2x0,85 cm]	P95	V2	5	—	—	—	—
	POL	[29,6x59,2x0,80 cm]	P109	V3	3	—	—	—	U3P3E3C2
60x60	RECT	[59,2x59,2x0,85 cm]	P105	V2	5	class 2	A	R10	36+ ≥0,42
	SOFT	[59,2x59,2x0,85 cm]	P105	V2	5	—	—	—	—
	POL	[59,2x59,2x0,80 cm]	P119	V3	3	—	—	—	U3P3E3C2
60x120	RECT	[59,2x118,4x0,98 cm]	P137	V2	5	class 2	A	R10	36+ ≥0,42
	SOFT	[59,2x118,4x0,98 cm]	P137	V2	5	—	—	—	—
	POL	[59,2x118,4x0,93 cm]	P157	V3	3	—	—	—	—
45x45	RECT	[44,4x44,4x0,82 cm]	P95	V2	5	class 2	A	R10	36+ ≥0,42
	SOFT	[44,4x44,4x0,82 cm]	P95	V2	5	—	—	—	—
	POL	[44,4x44,4x0,77 cm]	P109	V3	3	—	—	—	U3P3E3C2
45x90	RECT	[44,5x89,0x1,05 cm]	P133	V2	5	class 2	A	R10	36+ ≥0,42
	SOFT	[44,5x89,0x1,05 cm]	P133	V2	5	—	—	—	—
	POL	[44,5x89,0x0,98 cm]	P153	V3	3	—	—	—	U3P3E3C2
90x90	RECT	[89,0x89,0x1,05 cm]	P133	V2	5	class 2	A	R10	36+ ≥0,42
	SOFT	[89,0x89,0x1,05 cm]	P133	V2	5	—	—	—	—
	POL	[89,0x89,0x0,98 cm]	P153	V3	3	—	—	—	U3P3E3C2

FLINT GLACIAR ESTRUTURADO _ STRUCTURED

30x60	RECT	[29,6x59,2x0,85 cm]	P95	V2	5	class 3	B	R11	36+ ≥0,42	U4P3E3C2
60x60	RECT	[59,2x59,2x0,85 cm]	P105	V2	5	class 3	B	R11	36+ ≥0,42	U4P3E3C2

FLINT 3D GLACIAR

60x120	RECT	[59,2x118,4x0,98 cm]	P147	V2						
--------	------	------------------------	------	----	--	--	--	--	--	--

Estruturado _ Structured: Produtos que minimizam o risco de deslizamento.
 Estruturado _ Structured: Products that minimize the risk of slipping.
 Estruturado _ Structured: Produits qui réduisent le risque de glissement.
 Estruturado _ Structured: Productos que minimizan el riesgo de deslizamiento.

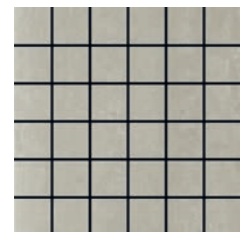

STRATUS 36
FLINT GLACIAR (a) (f)
30x30 P19/peça_pieza

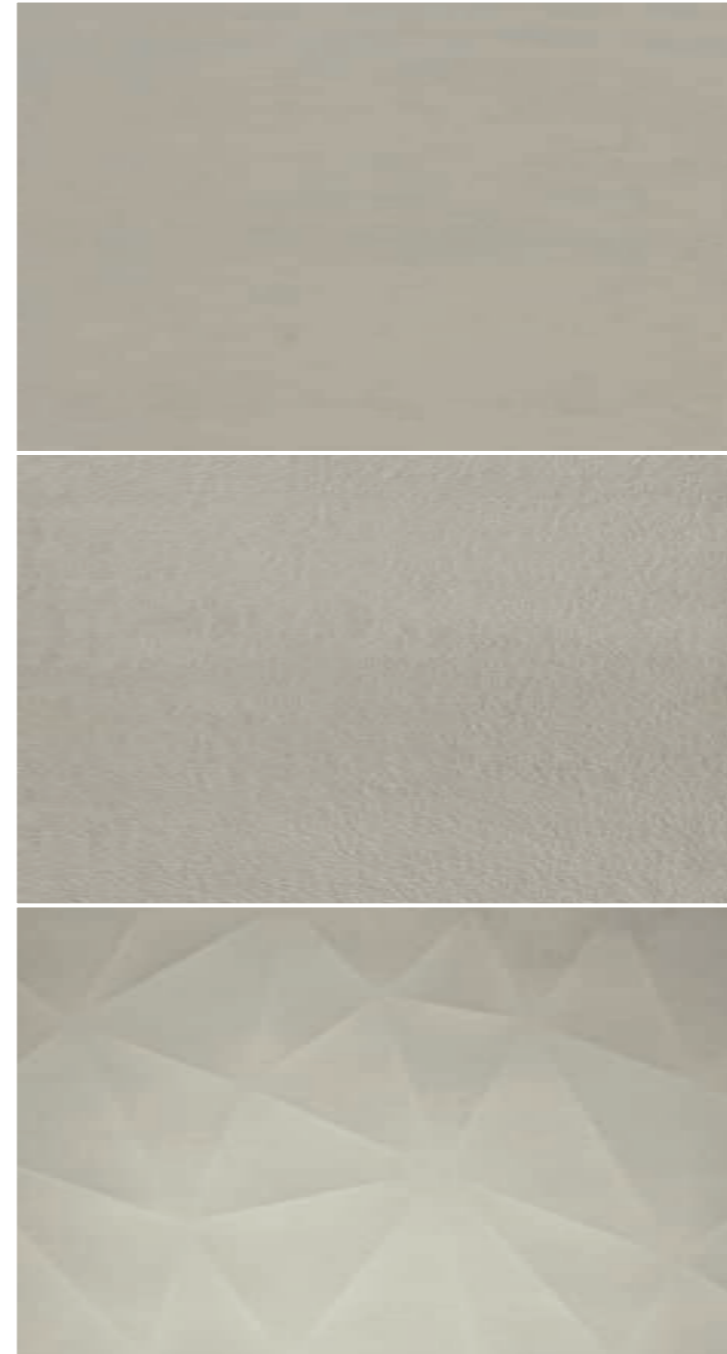

FLINT FOG

Size	Finish	Dimensions	Product Code	Profile	Height	Class	Grade	Water Absorption	Wear Resistance
30x30	RECT	[29,6x29,6x0,85 cm]	P89	V2	5	class 2	A	R10	36+ ≥0,42
	SOFT	[29,6x29,6x0,85 cm]	P89	V2	5	—	—	—	—
	POL	[29,6x29,6x0,80 cm]	P103	V3	3	—	—	—	U3P3E3C2
15x60	RECT	[14,7x59,2x0,85 cm]	P95	V2	5	class 2	A	R10	36+ ≥0,42
	SOFT	[14,7x59,2x0,85 cm]	P95	V2	5	—	—	—	—
30x60	RECT	[29,6x59,2x0,85 cm]	P85	V2	5	class 2	A	R10	36+ ≥0,42
	SOFT	[29,6x59,2x0,85 cm]	P85	V2	5	—	—	—	—
	POL	[29,6x59,2x0,80 cm]	P99	V3	3	—	—	—	U3P3E3C2
60x60	RECT	[59,2x59,2x0,85 cm]	P95	V2	5	class 2	A	R10	36+ ≥0,42
	SOFT	[59,2x59,2x0,85 cm]	P95	V2	5	—	—	—	—
	POL	[59,2x59,2x0,80 cm]	P109	V3	3	—	—	—	U3P3E3C2
60x120	RECT	[59,2x118,4x0,98 cm]	P127	V2	5	class 2	A	R10	36+ ≥0,42
	SOFT	[59,2x118,4x0,98 cm]	P127	V2	5	—	—	—	—
	POL	[59,2x118,4x0,93 cm]	P147	V3	3	—	—	—	—
45x45	RECT	[44,4x44,4x0,82 cm]	P85	V2	5	class 2	A	R10	36+ ≥0,42
	SOFT	[44,4x44,4x0,82 cm]	P85	V2	5	—	—	—	—
	POL	[44,4x44,4x0,77 cm]	P99	V3	3	—	—	—	U3P3E3C2
45x90	RECT	[44,5x89,0x1,05 cm]	P123	V2	5	class 2	A	R10	36+ ≥0,42
	SOFT	[44,5x89,0x1,05 cm]	P123	V2	5	—	—	—	—
	POL	[44,5x89,0x0,98 cm]	P143	V3	3	—	—	—	—
90x90	RECT	[89,0x89,0x1,05 cm]	P123	V2	5	class 2	A	R10	36+ ≥0,42
	SOFT	[89,0x89,0x1,05 cm]	P123	V2	5	—	—	—	—
	POL	[89,0x89,0x0,98 cm]	P143	V3	3	—	—	—	—

FLINT FOG ESTRUTURADO _ STRUCTURED

30x60	RECT	[29,6x59,2x0,85 cm]	P95	V2	5	class 3	B	R11	36+ ≥0,42	U4P3E3C2
60x60	RECT	[59,2x59,2x0,85 cm]	P95	V2	5	class 3	B	R11	36+ ≥0,42	U4P3E3C2

FLINT 3D FOG

60x120	RECT	[59,2x118,4x0,98 cm]	P137	V2						
--------	------	------------------------	------	----	--	--	--	--	--	--

Estruturado _ Structured: Produtos que minimizam o risco de deslizamento.
 Estruturado _ Structured: Products that minimize the risk of slipping.
 Estruturado _ Structured: Produits qui réduisent le risque de glissement.
 Estruturado _ Structured: Productos que minimizan el riesgo de deslizamiento.

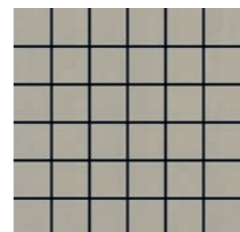

STRATUS 36
FLINT FOG (a) (f)
30x30 P19/peça_pieza

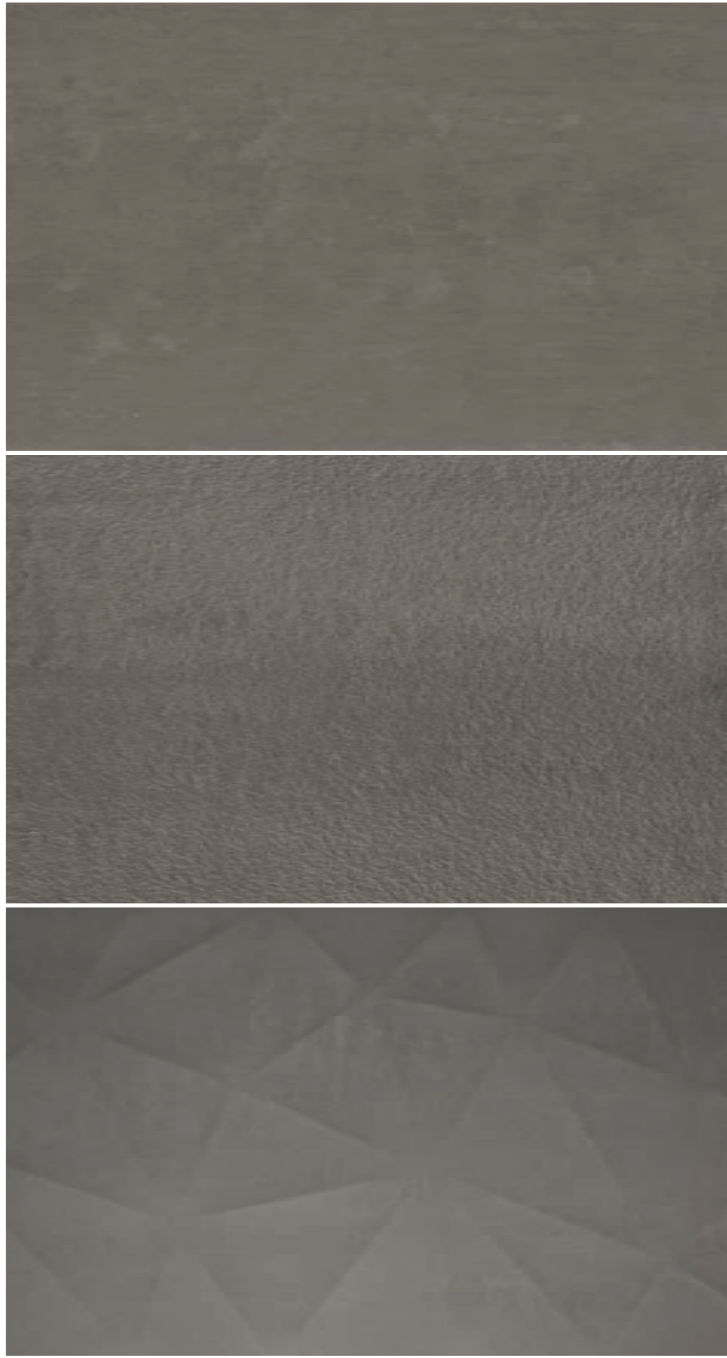

FLINT GRIS

30x30	RECT	[29,6x29,6x0,85 cm]	P89	V2	5	class 2	A	R10	36*	≥0,42	U4P3E3C2
	SOFT	[29,6x29,6x0,85 cm]	P89	V2	5	—	—	—	—	—	—
	POL	[29,6x29,6x0,80 cm]	P103	V3	3	—	—	—	—	—	U3P3E3C2
15x60	RECT	[14,7x59,2x0,85 cm]	P95	V2	5	class 2	A	R10	36*	≥0,42	—
	SOFT	[14,7x59,2x0,85 cm]	P95	V2	5	—	—	—	—	—	—
30x60	RECT	[29,6x59,2x0,85 cm]	P85	V2	5	class 2	A	R10	36*	≥0,42	U4P3E3C2
	SOFT	[29,6x59,2x0,85 cm]	P85	V2	5	—	—	—	—	—	—
	POL	[29,6x59,2x0,80 cm]	P99	V3	3	—	—	—	—	—	U3P3E3C2
60x60	RECT	[59,2x59,2x0,85 cm]	P95	V2	5	class 2	A	R10	36*	≥0,42	U4P3E3C2
	SOFT	[59,2x59,2x0,85 cm]	P95	V2	5	—	—	—	—	—	—
	POL	[59,2x59,2x0,80 cm]	P109	V3	3	—	—	—	—	—	U3P3E3C2
60x120	RECT	[59,2x118,4x0,98 cm]	P127	V2	5	class 2	A	R10	36*	≥0,42	—
	SOFT	[59,2x118,4x0,98 cm]	P127	V2	5	—	—	—	—	—	—
	POL	[59,2x118,4x0,93 cm]	P147	V3	3	—	—	—	—	—	U3P3E3C2
45x45	RECT	[44,4x44,4x0,82 cm]	P85	V2	5	class 2	A	R10	36*	≥0,42	U4P3E3C2
	SOFT	[44,4x44,4x0,82 cm]	P85	V2	5	—	—	—	—	—	—
	POL	[44,4x44,4x0,77 cm]	P99	V3	3	—	—	—	—	—	U3P3E3C2
45x90	RECT	[44,5x89,0x1,05 cm]	P123	V2	5	class 2	A	R10	36*	≥0,42	U4P3E3C2
	SOFT	[44,5x89,0x1,05 cm]	P123	V2	5	—	—	—	—	—	—
	POL	[44,5x89,0x0,98 cm]	P143	V3	3	—	—	—	—	—	U3P3E3C2
90x90	RECT	[89,0x89,0x1,05 cm]	P123	V2	5	class 2	A	R10	36*	≥0,42	U4P3E3C2
	SOFT	[89,0x89,0x1,05 cm]	P123	V2	5	—	—	—	—	—	—
	POL	[89,0x89,0x0,98 cm]	P143	V3	3	—	—	—	—	—	U3P3E3C2

FLINT GRIS ESTRUTURADO_STRUCTURED

30x60	RECT	[29,6x59,2x0,85 cm]	P85	V2	5	class 3	B	R11	36*	≥0,42	U4P3E3C2
60x60	RECT	[59,2x59,2x0,85 cm]	P95	V2	5	class 3	B	R11	36*	≥0,42	U4P3E3C2

FLINT 3D GRIS

60x120	RECT	[59,2x118,4x0,98 cm]	P137	V2
--------	------	----------------------	------	----

Estruturado_Structured: Produtos que minimizam o risco de deslizamento.
 Estruturado_Structured: Products that minimize the risk of slipping.
 Estruturado_Structured: Produits qui réduisent le risque de glissement.
 Estruturado_Structured: Productos que minimizan el riesgo de deslizamiento.



FLINT PRETO

30x30	RECT	[29,6x29,6x0,85 cm]	P89	V2	5	class 2	A	R10	36*	≥0,42	U4P3E3C2
	SOFT	[29,6x29,6x0,85 cm]	P89	V2	5	—	—	—	—	—	—
	POL	[29,6x29,6x0,80 cm]	P103	V3	3	—	—	—	—	—	U3P3E3C2
15x60	RECT	[14,7x59,2x0,85 cm]	P95	V2	5	class 2	A	R10	36*	≥0,42	—
	SOFT	[14,7x59,2x0,85 cm]	P95	V2	5	—	—	—	—	—	—
30x60	RECT	[29,6x59,2x0,85 cm]	P85	V2	5	class 2	A	R10	36*	≥0,42	U4P3E3C2
	SOFT	[29,6x59,2x0,85 cm]	P85	V2	5	—	—	—	—	—	—
	POL	[29,6x59,2x0,80 cm]	P99	V3	3	—	—	—	—	—	U3P3E3C2
60x60	RECT	[59,2x59,2x0,85 cm]	P95	V2	5	class 2	A	R10	36*	≥0,42	U4P3E3C2
	SOFT	[59,2x59,2x0,85 cm]	P95	V2	5	—	—	—	—	—	—
	POL	[59,2x59,2x0,80 cm]	P109	V3	3	—	—	—	—	—	U3P3E3C2
60x120	RECT	[59,2x118,4x0,98 cm]	P127	V2	5	class 2	A	R10	36*	≥0,42	U4P3E3C2
	SOFT	[59,2x118,4x0,98 cm]	P127	V2	5	—	—	—	—	—	—
	POL	[59,2x118,4x0,93 cm]	P147	V3	3	—	—	—	—	—	U3P3E3C2
45x45	RECT	[44,4x44,4x0,82 cm]	P85	V2	5	class 2	A	R10	36*	≥0,42	U4P3E3C2
	SOFT	[44,4x44,4x0,82 cm]	P85	V2	5	—	—	—	—	—	—
	POL	[44,4x44,4x0,77 cm]	P99	V3	3	—	—	—	—	—	U3P3E3C2
45x90	RECT	[44,5x89,0x1,05 cm]	P123	V2	5	class 2	A	R10	36*	≥0,42	—
	SOFT	[44,5x89,0x1,05 cm]	P123	V2	5	—	—	—	—	—	—
	POL	[44,5x89,0x0,98 cm]	P143	V3	3	—	—	—	—	—	U3P3E3C2
90x90	RECT	[89,0x89,0x1,05 cm]	P123	V2	5	class 2	A	R10	36*	≥0,42	—
	SOFT	[89,0x89,0x1,05 cm]	P123	V2	5	—	—	—	—	—	—
	POL	[89,0x89,0x0,98 cm]	P143	V3	3	—	—	—	—	—	U3P3E3C2

FLINT PRETO ESTRUTURADO_STRUCTURED

30x60	RECT	[29,6x59,2x0,85 cm]	P85	V2	5	class 3	B	R11	36*	≥0,42	U4P3E3C2
60x60	RECT	[59,2x59,2x0,85 cm]	P95	V2	5	class 3	B	R11	36*	≥0,42	U4P3E3C2

FLINT 3D PRETO

60x120	RECT	[59,2x118,4x0,98 cm]	P137	V2
--------	------	----------------------	------	----

Estruturado_Structured: Produtos que minimizam o risco de deslizamento.
 Estruturado_Structured: Products that minimize the risk of slipping.
 Estruturado_Structured: Produits qui réduisent le risque de glissement.
 Estruturado_Structured: Productos que minimizan el riesgo de deslizamiento.



STRATUS 36
FLINT GRIS (a) (f)
30x30 P19/peça_pieza



STRATUS 36
FLINT PRETO (a) (f)
30x30 P19/peça_pieza

Full body

Full body



Flint 3D Ice

ZOOM

PEÇA_PIECE			PEÇA_PIECE			PEÇA_PIECE			PEÇA_PIECE		
DG	Rect / Soft	Pol	RB	Rect / Soft	Pol	BR	Rect / Soft	Pol	TC	Rect / Soft	Pol
30x30 cm	P10	P10	9,5x30 cm	P08	P08	7x30 cm	P06	P06	7x7 cm	P01	P02
30x60 cm	P18	P18	8x45 cm	P08	P08	7x45 cm	P08	P08			
45x45 cm	P18	P18	8x60 cm	P12	P12	7x60 cm	P09	P09			
60x60 cm	P36	P36	8x90 cm	P28	P28						
45x90 cm	P97	P97	8x120 cm	P28	P28						
30x120 cm	P97	P97									
60x120 cm	P167	P167									



PEÇA_PIECE			PEÇA_PIECE		
DG CF	Rect / Soft	Pol	DG CF CANTO	Rect / Soft	Pol
30x60 cm	P157	P157	30x60 cm	P207	P207

DG CF / DG CF Canto: Peças produzidas sob encomenda.
 DG CF / DG CF Canto: Pieces produced on order.
 DG CF / DG CF Canto: Pièces produites sur commande.
 DG CF / DG CF Canto: Piezas producidas por encargo.

DG CF Canto: Disponível em canto esquerdo e direito.
 DG CF Canto: Available in left and right corner.
 DG CF Canto: Disponible en angle gauche et droit.
 DG CF Canto: Canto izquierdo y derecho disponibles.



Flint Gris

Revestimentos e pavimentos para interior com elevada resistência.
High-resistance wall and floor tiles for indoor use.
Revêtements muraux et revêtements sol intérieurs avec une grande résistance.
Revestimientos y pavimentos para interior con una elevada resistencia.

Dual



Dual Marfim
Hotéis Do Grupo Vila Galé - Portugal _ Vila Galé Group Hotels - Portugal



Dual Superpreto
Hotéis Do Grupo Vila Galé - Portugal _ Vila Galé Group Hotels - Portugal

06

cores
couleurs
colores

03

formatos
formats
formatos

02

acabamentos
finishes
finitions
acabados



Full body



Marfim



30x30 (12"x12")
[29,6x29,6 cm]
RECT \pm 0,85 cm
POL \pm 0,80 cm



Platina



30x60 (12"x24")
[29,6x59,2 cm]
RECT \pm 0,85 cm
POL \pm 0,80 cm



Arg Prata



60x60 (24"x24")
[59,2x59,2 cm]
RECT \pm 0,85 cm
POL \pm 0,80 cm



Grafite



Preto

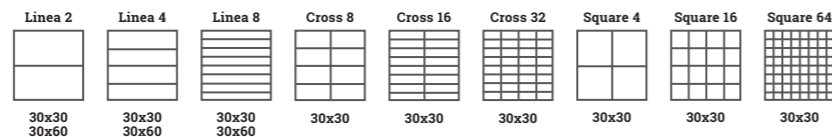

Pág. 50

Superpreto

	Peças / Pieces	Espessura (mm) / Thickness (mm)	Caixas / Box		Europalets / Europallet		Peso (Kg) / Weight (Kg)
			Nº Peças / No Pieces	M² Aprox. / No of Sq. M. Approx.	Nº Caixas / No Boxes	M² Aprox. / No of Sq. M. Approx.	
30x30 cm	Rect	\pm 8,5 ±5%	10	0.90	64	57.60	1 173
	Pol	\pm 8,0 ±5%	10	0.90	64	57.60	1 045
30x60 cm	Rect	\pm 8,5 ±5%	5	0.90	60	54.00	1 101
	Pol	\pm 8,0 ±5%	5	0.90	60	54.00	981
60x60 cm	Rect	\pm 8,5 ±5%	4	1.44	36	51.84	1 053
	Pol	\pm 8,0 ±5%	4	1.44	36	51.84	981

De modo a proteger a superfície das peças, os produtos no acabamento polido têm uma fina camada de impermeabilizante, que apenas deve ser removida após a conclusão da obra.
Tiles with polished finish are protected with waterproof coating that must be removed only after the works are concluded.
En vue de protéger la surface des pièces, les produits à la finition polie ont une fine couche d'imperméabilisant qui ne devrait être enlevée qu'après l'achèvement des travaux.
Con el fin de proteger la superficie de las piezas, los productos con acabado pulido tienen una fina capa de impermeabilizante, que solo debe eliminarse una vez terminado el trabajo.



Dual Preto

Full body



GRAPHIC VARIATION

Os desenhos das peças intensificam-se no acabamento polido, aumentando a variação de desenhos e de cores, entre peças.
The designs of the pieces are more intense in the polished finish, enhancing design and colour variation across pieces.
Les dessins des pièces s'intensifient avec la finition polie, augmentant la variation des dessins et des couleurs entre les pièces.
Los diseños de las piezas se intensifican con el acabado pulido, aumentando la variación de diseños y colores entre las piezas.

Full body



DUAL MARFIM

Size	Finish	Dimensions	Code	Class	A	R10	36*	≥0,42	U4P4E3C2
30x30	RECT	[29,6x29,6x0,85 cm]	P95	V3	class 2	A	R10	36*	≥0,42
	POL	[29,6x29,6x0,80 cm]	P109	V3	—	—	—	—	U3P3E3C2
30x60	RECT	[29,6x59,2x0,85 cm]	P91	V3	class 2	A	R10	36*	≥0,42
	POL	[29,6x59,2x0,80 cm]	P105	V3	—	—	—	—	U3P3E3C2
60x60	RECT	[59,2x59,2x0,85 cm]	P101	V3	class 2	A	R10	36*	≥0,42
	POL	[59,2x59,2x0,80 cm]	P115	V3	—	—	—	—	U3P3E3C2

DUAL PLATINA

Size	Finish	Dimensions	Code	Class	A	R10	36*	≥0,42	U4P4E3C2
30x30	RECT	[29,6x29,6x0,85 cm]	P95	V3	class 2	A	R10	36*	≥0,42
	POL	[29,6x29,6x0,80 cm]	P109	V3	—	—	—	—	U3P3E3C2
30x60	RECT	[29,6x59,2x0,85 cm]	P91	V3	class 2	A	R10	36*	≥0,42
	POL	[29,6x59,2x0,80 cm]	P105	V3	—	—	—	—	U3P3E3C2
60x60	RECT	[59,2x59,2x0,85 cm]	P101	V3	class 2	A	R10	36*	≥0,42
	POL	[59,2x59,2x0,80 cm]	P115	V3	—	—	—	—	U3P3E3C2

DUAL ARG PRATA

Size	Finish	Dimensions	Code	Class	A	R10	36*	≥0,42	U4P4E3C2
30x30	RECT	[29,6x29,6x0,85 cm]	P89	V3	class 2	A	R10	36*	≥0,42
	POL	[29,6x29,6x0,80 cm]	P103	V3	—	—	—	—	U3P3E3C2
30x60	RECT	[29,6x59,2x0,85 cm]	P85	V3	class 2	A	R10	36*	≥0,42
	POL	[29,6x59,2x0,80 cm]	P99	V3	—	—	—	—	U3P3E3C2
60x60	RECT	[59,2x59,2x0,85 cm]	P95	V3	class 2	A	R10	36*	≥0,42
	POL	[59,2x59,2x0,80 cm]	P109	V3	—	—	—	—	U3P3E3C2

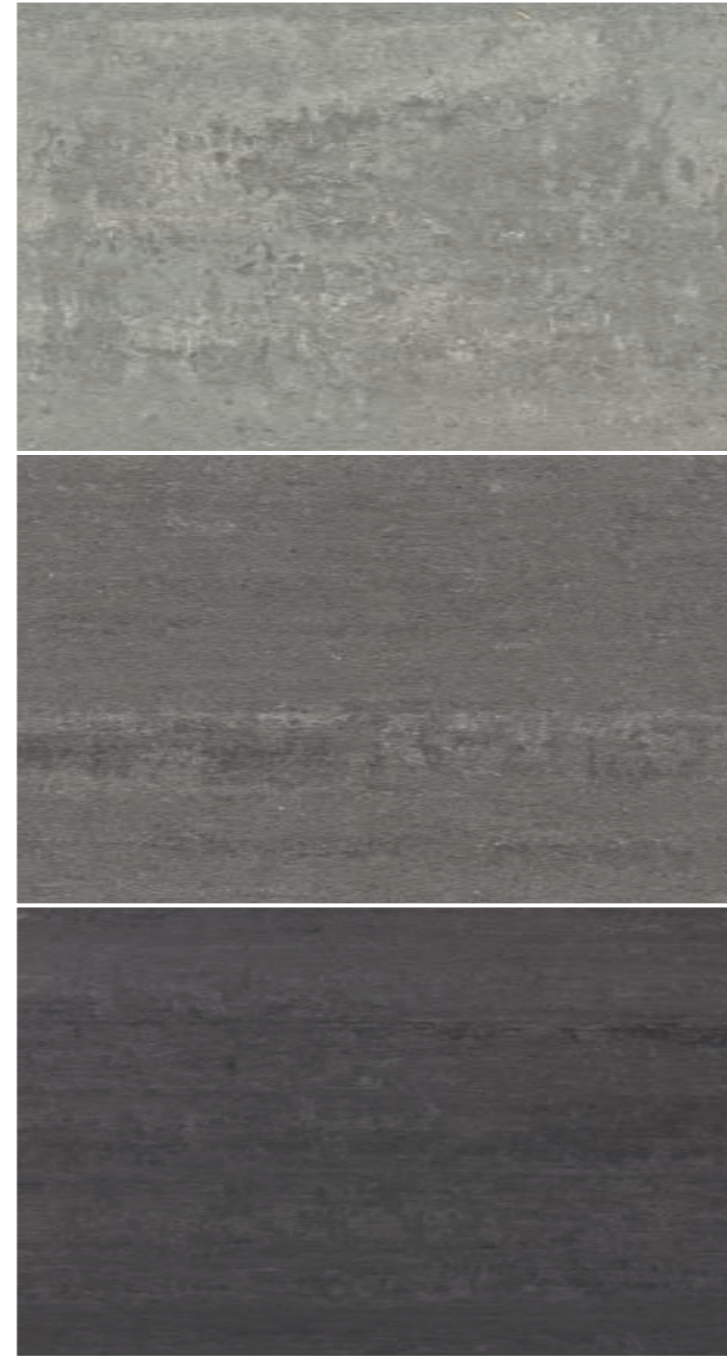

DUAL GRAFITE

Size	Finish	Dimensions	Code	Class	A	R10	36*	≥0,42	U4P4E3C2
30x30	RECT	[29,6x29,6x0,85 cm]	P89	V3	class 2	A	R10	36*	≥0,42
	POL	[29,6x29,6x0,80 cm]	P103	V3	—	—	—	—	U3P3E3C2
30x60	RECT	[29,6x59,2x0,85 cm]	P85	V3	class 2	A	R10	36*	≥0,42
	POL	[29,6x59,2x0,80 cm]	P99	V3	—	—	—	—	U3P3E3C2
60x60	RECT	[59,2x59,2x0,85 cm]	P95	V3	class 2	A	R10	36*	≥0,42
	POL	[59,2x59,2x0,80 cm]	P109	V3	—	—	—	—	U3P3E3C2

DUAL PRETO

Size	Finish	Dimensions	Code	Class	A	R10	36*	≥0,42	U4P4E3C2
30x30	RECT	[29,6x29,6x0,85 cm]	P89	V3	class 2	A	R10	36*	≥0,42
	POL	[29,6x29,6x0,80 cm]	P103	V3	—	—	—	—	U3P3E3C2
30x60	RECT	[29,6x59,2x0,85 cm]	P85	V3	class 2	A	R10	36*	≥0,42
	POL	[29,6x59,2x0,80 cm]	P99	V3	—	—	—	—	U3P3E3C2
60x60	RECT	[59,2x59,2x0,85 cm]	P95	V3	class 2	A	R10	36*	≥0,42
	POL	[59,2x59,2x0,80 cm]	P109	V3	—	—	—	—	U3P3E3C2

DUAL SUPERPRETO

Size	Finish	Dimensions	Code	Class	A	R10	36*	≥0,42	U4P4E3C2
30x30	RECT	[29,6x29,6x0,85 cm]	P89	V3	class 2	A	R10	36*	≥0,42
	POL	[29,6x29,6x0,80 cm]	P103	V3	—	—	—	—	U3P3E3C2
30x60	RECT	[29,6x59,2x0,85 cm]	P85	V3	class 2	A	R10	36*	≥0,42
	POL	[29,6x59,2x0,80 cm]	P99	V3	—	—	—	—	U3P3E3C2
60x60	RECT	[59,2x59,2x0,85 cm]	P95	V3	class 2	A	R10	36*	≥0,42
	POL	[59,2x59,2x0,80 cm]	P109	V3	—	—	—	—	U3P3E3C2

Full body

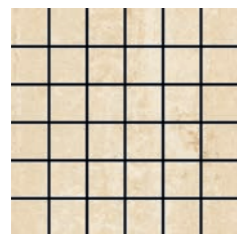

STRATUS 36
DUAL MARFIM (a) (f)
30x30 P19 /peça_pieça



STRATUS 36
DUAL PLATINA (a) (f)
30x30 P19 /peça_pieça



STRATUS 36
DUAL ARG PRATA (a) (f)
30x30 P19 /peça_pieça



STRATUS 36
DUAL GRAFITE (a) (f)
30x30 P19 /peça_pieça



STRATUS 36
DUAL PRETO (a) (f)
30x30 P19 /peça_pieça

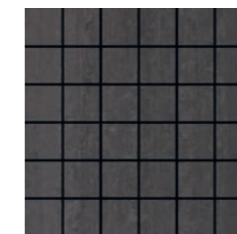

STRATUS 36
DUAL SUPERPRETO (a) (f)
30x30 P19 /peça_pieça

Full body



Dual Grafite
Centro Comercial - Khabarovsk, Rússia _ Shopping Center - Khabarovsk, Russia

PEÇA _ PIECE			PEÇA _ PIECE			PEÇA _ PIECE			PEÇA _ PIECE		
DG	Rect	Pol	RB	Rect	Pol	BR	Rect	Pol	TC	Rect	Pol
30x30 cm	P10	P10	9,5x30 cm	P08	P08	7x30 cm	P06	P06	7x7 cm	P02	P02
30x60 cm	P18	P18	8x60 cm	P12	P12	7x60cm	P09	P09			
60x60 cm	P36	P36									

PEÇA _ PIECE			PEÇA _ PIECE		
DG CF	Rect	Pol	DG CF CANTO	Rect	Pol
30x60 cm	P157	P157	30x60 cm	P207	P207

DG CF / DG CF Canto: Peças produzidas sob encomenda.
DG CF / DG CF Canto: Pieces produced on order.
DG CF / DG CF Canto: Pièces produites sur commande.
DG CF / DG CF Canto: Piezas producidas por encargo.

DG CF Canto: Disponível em canto esquerdo e direito.
DG CF Canto: Available in left and right corner.
DG CF Canto: Disponible en angle gauche et droit.
DG CF Canto: Canto izquierdo y derecho disponibles.

Full body



Dual Platina
Dual Preto
Hotéis Do Grupo Vila Galé - Portugal _ Vila Galé Group Hotels - Portugal

Soluções com elevada qualidade técnica e resistência para espaços públicos com tráfego elevado.
High technical quality and resistance solutions for heavy-duty public spaces.
Des solutions à la qualité technique élevée et qui présente une haute résistance pour les espaces publics au trafic intense.
Soluciones con gran calidad técnica y resistencia para espacios públicos con mucho tráfico.

Pigmento Java



Pigmento Grafite

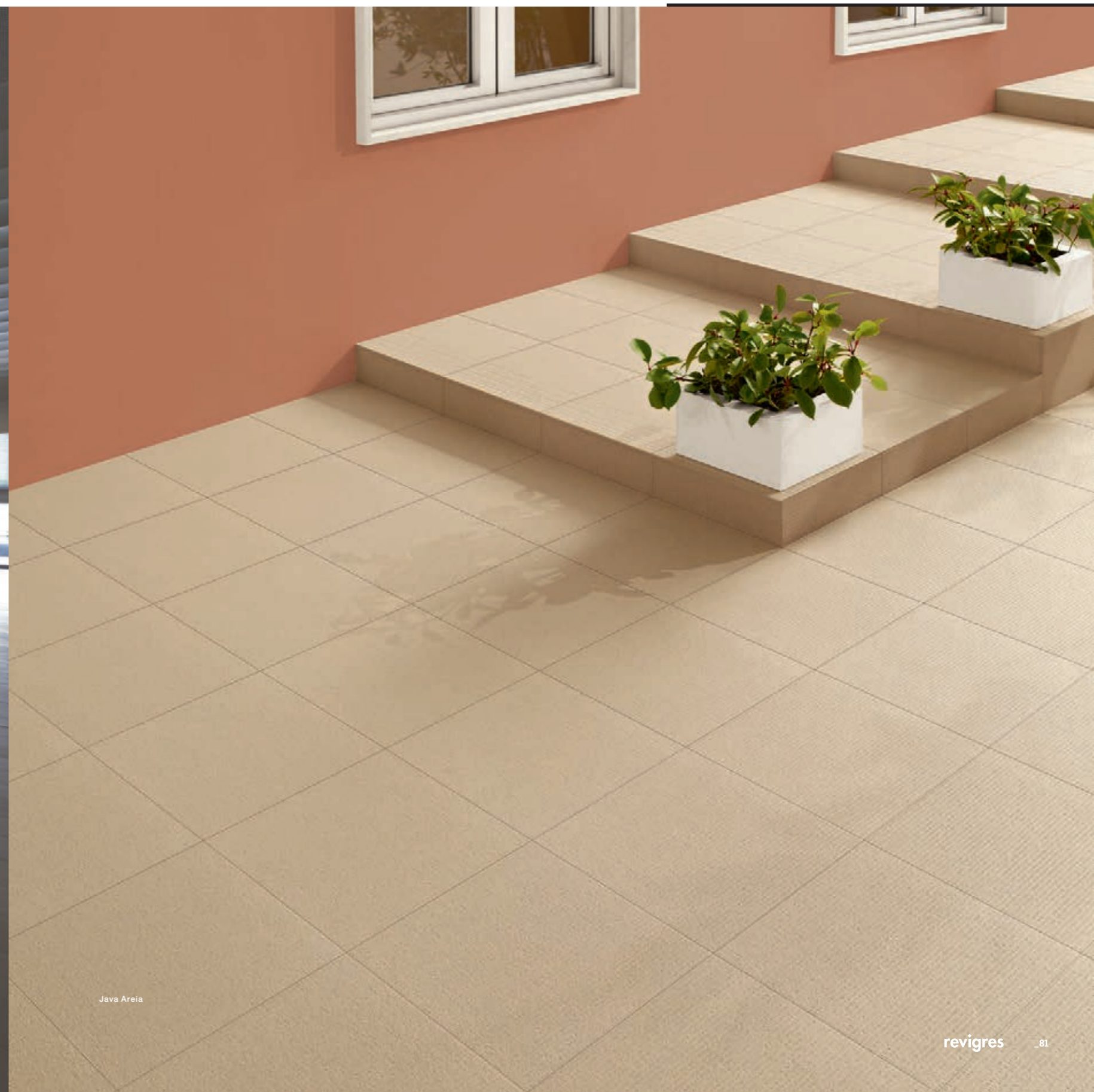

Java Areia

Pigmento

- 04** cores colors couleurs
- 01** formato format format
- 02** acabamentos finishes finitions acabados

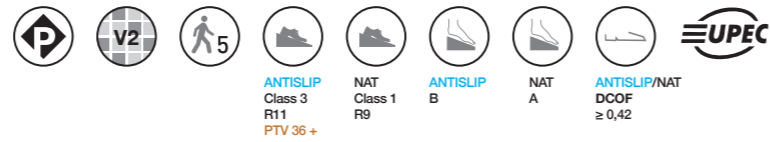

30x30 (12"x12")
NAT ± 0,70 cm



Pigmento Grafite

Areia

Luna

Chumbo

Grafite

PEÇA_PIECE		PEÇA_PIECE		PEÇA_PIECE		
DG	NAT	RB	NAT	NAT		
30x30 cm	P07	9,5x30 cm	P04	03x10	AEBBC / AIBBC / AERBC / AIRBC	P09
				10x30	RBBC / RRBC	P09

Estas peças são produzidas de acordo com quantidades mínimas.
These tiles are produced in minimum quantities.
La fabrication de ces pièces est soumise à des quantités minimales.
Estas piezas se producen en cantidades mínimas.

Peças_Pieces		Caixa_Box			Europaleta_Europallet			
30x30 cm	Nat	Espesura (mm) Thickness (mm)	Nº Peças No Pieces	M² Aprox. No of Sq. M. Approx.	Peso (Kg) Weight Kg	Nº Caixas No Boxes	M² Aprox. No of Sq. M. Approx.	Peso (Kg) Weight (Kg)
30x30 cm	Nat	± 7,0 ±5%	10	0.9	15	68	61.2	1 041

Pigmento

PIGMENTO AREIA

30x30	NAT	[...x0,70 cm]	P60	V2	5	class 1	A	R9	—	≥0,42	U4P3E3C2
-------	-----	---------------	-----	----	---	---------	---	----	---	-------	----------

PIGMENTO AREIA

30x30	ANTI SLIP NAT	[...x0,70 cm]	P63	V2	5	class 3	B	R11	36*	≥0,42	U4P3E3C2
-------	---------------	---------------	-----	----	---	---------	---	-----	-----	-------	----------

PIGMENTO LUNA

30x30	NAT	[...x0,70 cm]	P60	V2	5	class 1	A	R9	—	≥0,42	U4P3E3C2
-------	-----	---------------	-----	----	---	---------	---	----	---	-------	----------

PIGMENTO LUNA

30x30	ANTI SLIP NAT	[...x0,70 cm]	P63	V2	5	class 3	B	R11	36*	≥0,42	U4P3E3C2
-------	---------------	---------------	-----	----	---	---------	---	-----	-----	-------	----------

PIGMENTO CHUMBO

30x30	NAT	[...x0,70 cm]	P60	V2	5	class 1	A	R9	—	≥0,42	U4P3E3C2
-------	-----	---------------	-----	----	---	---------	---	----	---	-------	----------

PIGMENTO CHUMBO

30x30	ANTI SLIP NAT	[...x0,70 cm]	P63	V2	5	class 3	B	R11	36*	≥0,42	U4P3E3C2
-------	---------------	---------------	-----	----	---	---------	---	-----	-----	-------	----------

PIGMENTO GRAFITE

30x30	NAT	[...x0,70 cm]	P63	V2	5	class 1	A	R9	—	≥0,42	U4P3E3C2
-------	-----	---------------	-----	----	---	---------	---	----	---	-------	----------

PIGMENTO GRAFITE

30x30	ANTI SLIP NAT	[...x0,70 cm]	P66	V2	5	class 3	B	R11	36*	≥0,42	U4P3E3C2
-------	---------------	---------------	-----	----	---	---------	---	-----	-----	-------	----------

AntiSlip: Produtos que minimizam o risco de deslizamento.
AntiSlip: Products that minimize the risk of slipping.
AntiSlip: Produits qui réduisent le risque de glissement.
AntiSlip: Productos que minimizan el riesgo de deslizamiento.

Java

03 cores
colors
couleurs
couleurs

01 formato
format
format
formato

01 acabamento
finish
finition
acabado

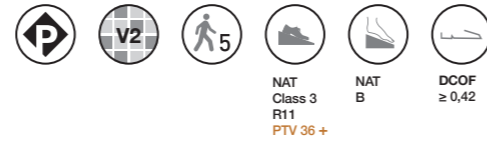

30x30 (12"x12")
NAT $\pm 0,77$ cm

Areia



Java Areia

Luna



JAVA AREIA

30x30	NAT	[...x0,77 cm]	P63	V2	5	class 3	B	R11	36*	≥0,42
-------	-----	----------------	-----	----	---	---------	---	-----	-----	-------

JAVA LUNA

30x30	NAT	[...x0,77 cm]	P63	V2	5	class 3	B	R11	36*	≥0,42
-------	-----	----------------	-----	----	---	---------	---	-----	-----	-------

Chumbo

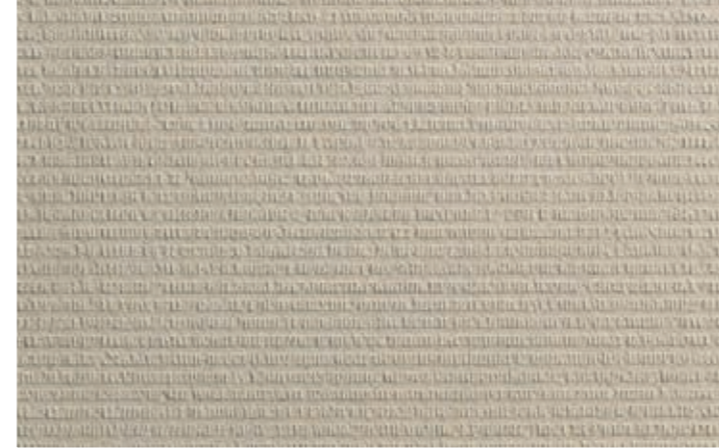

JAVA CHUMBO

30x30	NAT	[...x0,77 cm]	P63	V2	5	class 3	B	R11	36*	≥0,42
-------	-----	----------------	-----	----	---	---------	---	-----	-----	-------



	PEÇA _ PIECE		PEÇA _ PIECE	
DG	NAT	RB	NAT	
30x30 cm	P07	9,5x30 cm	P04	

Peças _ Pieces		Caixa _ Box			Europaleta _ Europallet			
30x30 cm	Nat	Espeçura (mm) Thickness (mm)	Nº Peças No Pieces	M² Aprox. No of Sq. M. Approx.	Peso (Kg) Weight Kg	Nº Caixas No Boxes	M² Aprox. No of Sq. M. Approx.	Peso (Kg) Weight (Kg)
30x30 cm	Nat	$\pm 7,7 \pm 5\%$	10	0.9	17.5	64	57.6	1 141

Java: Produtos que minimizam o risco de deslizamento.
Java: Products that minimize the risk of slipping.
Java: Produits qui réduisent le risque de glissement.
Java: Productos que minimizan el riesgo de deslizamiento.



Ecotiles

Página
Page
Page
Página

Ecotech 088

Saturno 092

A Nossa Cerâmica é Verde

Soluções de cerâmica que integram até 90% de materiais reciclados para promover a sustentabilidade ambiental.

Our Tiles Are Green

Ceramic solutions containing up to 90% recycled materials for promoting environmental sustainability.

Notre Céramique Est Verte

Solutions en céramique qui intègrent jusqu'à 90% de matériaux recyclés afin de promouvoir la durabilité environnementale.

Nuestra Cerámica Es Verde

Soluciones de cerámica que incluyen hasta un 90 % de materiales reciclados para favorecer la sostenibilidad medioambiental.

Proteger o ambiente passa por escolher produtos com materiais reciclados.
Selecting products made from recycled materials is essential for protecting the environment.
Protéger l'environnement passe par le choix des produits fabriqués à partir de matériaux recyclés.
Proteger el medioambiente pasa por elegir productos con materiales reciclados.

Ecotech



Ecotech Preto



Ecotech Cinza

- 02** cores
colors
couleurs
colores
- 01** formato
format
format
formato
- 01** acabamento
finish
finition
acabado

NAT
R10
Class 3
FTV 36 +

NAT
B

DCOF
≥ 0,42

ECO TILES
 PRODUTO QUE INTEGRA MATERIAIS RECICLADOS
 PRODUCT THAT INCORPORATES RECYCLED MATERIALS
 PRODUIT INTEGRANT DES MATÉRIEAUX RECYCLÉS
 DAS PRODUKT ENTHÄLT RECYCELTES MATERIAL
 PRODUCTO QUE INCORPORA MATERIALES RECICLADOS

45x45 (18"x18")
 NAT ± 0,82 cm



Cinza



Preto



Declaração de verificação de dados com vista a confirmar a percentagem de materiais reciclados nos produtos cerâmicos.

Statement of verification of data with a view to confirming the percentage of materials recycled in the ceramic products.

Déclaration de vérification de données en vue de confirmer le pourcentage de matériaux recyclés dans les produits céramiques.

Declaración de comprobación de datos con el fin de confirmar el porcentaje de materiales reciclados en nuestros productos cerámicos.

	PEÇA _ PIECE		PEÇA _ PIECE	
DG	NAT	RB	NAT	
45x45 cm	P10	8x45 cm	P07	

Peças _ Pieces		Caixa _ Box			Europaleta _ Europallet			
	Espesura (mm) Thickness (mm)	Nº Peças No of Pieces	M² Aprox. No of Sq. M. Approx.	Peso (Kg) Weight Kg	Nº Caixas No of Boxes	M² Aprox. No of Sq. M. Approx.	Peso (Kg) Weight (Kg)	
45x45 cm	Nat	± 8,2 ±5%	6	1,22	24	34	41,48	837

ECOTECH CINZA

45x45	NAT	[...x0,82 cm]	P64	V3	A4	class 3	B	R10	36+	≥0,42
-------	-----	---------------	-----	----	----	---------	---	-----	-----	-------

ECO TILE
90%



ECOTECH PRETO

45x45	NAT	[...x0,82 cm]	P64	V3	A4	class 3	B	R10	36+	≥0,42
-------	-----	---------------	-----	----	----	---------	---	-----	-----	-------

ECO TILE
90%

Ecotech: Produtos que minimizam o risco de deslizamento.
 Ecotech: Products that minimize the risk of slipping.
 Ecotech: Produits qui réduisent le risque de glissement.
 Ecotech: Productos que minimizan el riesgo de deslizamiento.

Este produto integra uma elevada percentagem de materiais reciclados, pelo que a cor pode variar de produção para produção.
 This product incorporates a high percentage of recycled materials, so colour may vary from production to production.
 Ce produit contient un pourcentage élevé de matériaux recyclés. La couleur peut donc varier d'une production à l'autre.
 Este producto incorpora un alto porcentaje de materiales reciclados, por lo que su color puede variar de una producción a otra.

Pavimentos antiderrapantes garantem a segurança em balneários de espaços desportivos.
Non-slip floor tiles ensure safety in sports changing rooms.
Revêtements de sol antidérapants assurant la sécurité dans les vestiaires des espaces sportifs.
Pavimentos antideslizantes garantizan la seguridad en vestuarios de instalaciones deportivas.

Saturno

Antiderrapante Saturno



Antiderrapante Saturno



Saturno

Este produto integra uma elevada percentagem de materiais reciclados, pelo que a cor pode variar de produção para produção.
This product incorporates a high percentage of recycled materials, so colour may vary from production to production.
Ce produit contient un pourcentage élevé de matériaux recyclés. La couleur peut donc varier d'une production à l'autre.
Este producto incorpora un alto porcentaje de materiales reciclados, por lo que su color puede variar de una producción a otra.

Saturno / Antiderrapante Saturno

- 01** cor color / couleur / color
- 01** formato format / format / formato
- 02** acabamentos finishes / finitions / acabados



ANTIDERRAPANTE R12 Class 3 PTV 36+
 NAT R9 Class 1
 NAT A
 ANTIDERRAPANTE C
 ANTIDERRAPANTE NAT DCOF ≥ 0,42



30x30 (12"x12")
 NAT ± 0,70 cm

ECO TILES
 PRODUTO QUE INTEGRA MATERIAIS RECICLADOS
 PRODUCT THAT INCORPORATES RECYCLED MATERIALS
 PRODUIT INTEGRANT DES MATÉRIEAUX RECYCLÉS
 DAS PRODUKT ENTHÄLT RECYCELTES MATERIAL
 PRODUCTO QUE INCORPORA MATERIALES RECICLADOS



Declaração de verificação de dados com vista a confirmar a percentagem de materiais reciclados nos produtos cerâmicos.
 Statement of verification of data with a view to confirming the percentage of materials recycled in the ceramic products.
 Déclaration de vérification de données en vue de confirmer le pourcentage de matériaux recyclés dans les produits céramiques.
 Declaración de comprobación de datos con el fin de confirmar el porcentaje de materiales reciclados en nuestros productos cerámicos.

	PEÇA _ PIECE	PEÇA _ PIECE
DG	NAT	NAT
30x30 cm	P07	9,5x30 cm P04

Peças _ Pieces	Caixa _ Box			Europalet _ Europallet			
	Espessura (mm) / Thickness (mm)	Nº Peças / No Pieces	M² Aprox. / No of Sq. M. Approx.	Peso (Kg) / Weight Kg	Nº Caixas / No Boxes	M² Aprox. / No of Sq. M. Approx.	Peso (Kg) / Weight (Kg)
30x30 cm Nat	± 7,0 ±5%	10	0,9	15	68	61,2	1 041

Saturno / Antiderrapante Saturno



SATURNO

30x30	NAT	[...x0,70 cm]	P56	V3	5	class 1	A	R9	-	≥0,42
-------	-----	---------------	-----	----	---	---------	---	----	---	-------

ANTIDERRAPANTE SATURNO

30x30	NAT	[...x0,70 cm]	P56	V3	5	class 3	C	R12	36+	≥0,42
-------	-----	---------------	-----	----	---	---------	---	-----	-----	-------

GRAPHIC VARIATION



ANTIDERRAPANTE: Produtos que minimizam o risco de deslizamento.
ANTIDERRAPANTE: Products that minimize the risk of slipping.
ANTIDERRAPANTE: Produits qui réduisent le risque de glissement.
ANTIDERRAPANTE: Productos que minimizan el riesgo de deslizamiento.

Este produto integra uma elevada percentagem de materiais reciclados, pelo que a cor pode variar de produção para produção.
 This product incorporates a high percentage of recycled materials, so colour may vary from production to production.
 Ce produit contient un pourcentage élevé de matériaux recyclés. La couleur peut donc varier d'une production à l'autre.
 Este producto incorpora un alto porcentaje de materiales reciclados, por lo que su color puede variar de una producción a otra.

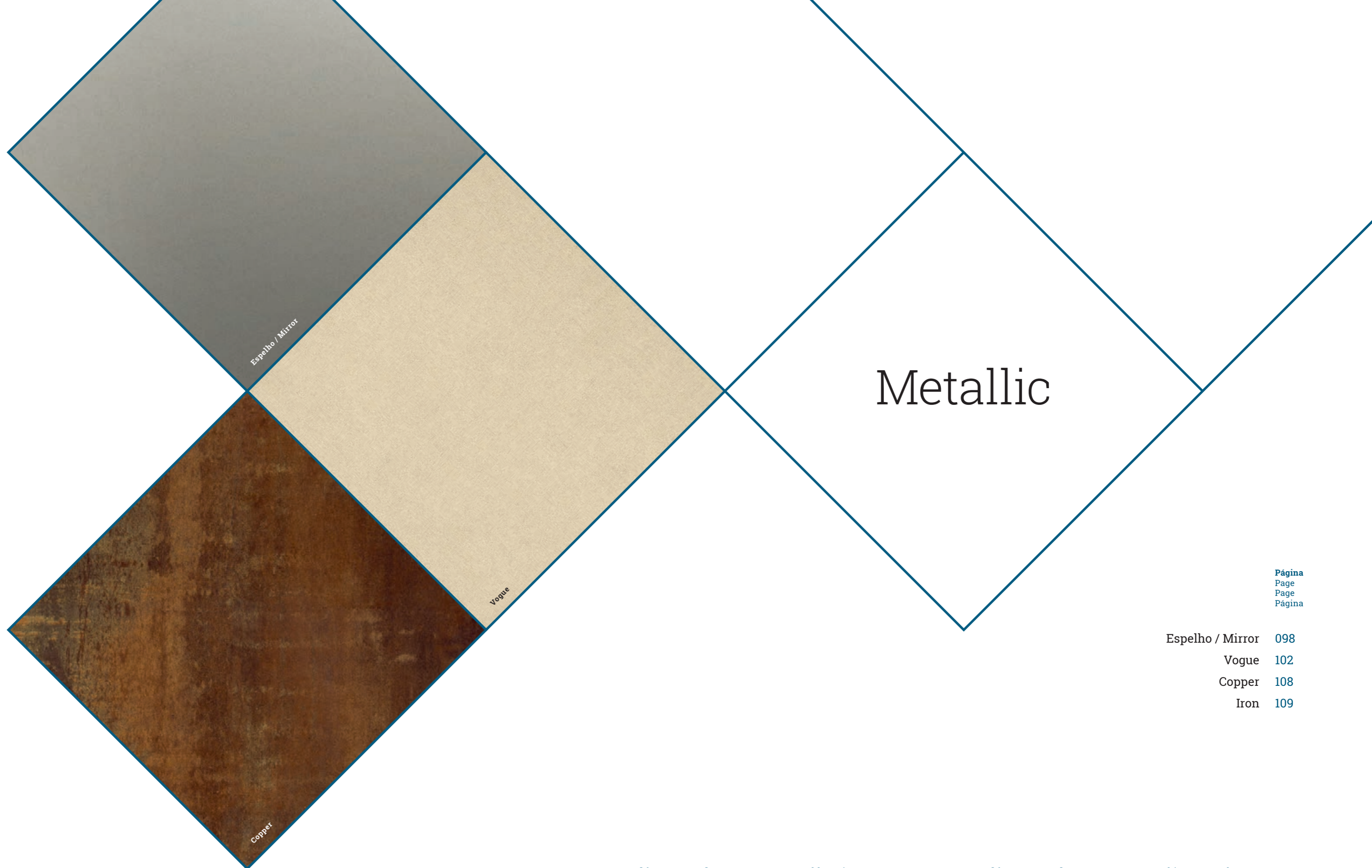

Página
Page
Page
Página

Espelho / Mirror	098
Vogue	102
Copper	108
Iron	109

Ambientes Ousados

Cerâmica com efeitos metálicos que permite criar ambientes modernos e quebrar a monotonia.

Bold Environments

Ceramics with metallic effects for modern and surprising environments.

Ambiences Branchés

Céramique aux effets métallisés qui permet de créer des atmosphères modernes et d'en finir avec la monotonie.

Ambientes Osados

Cerámica con efectos metalizados que permite crear ambientes modernos y romper con la monotonia.

O efeito do espelho para otimizar o espaço e criar profundidade.
Mirror effects that create depth and optimise space.
L'effet miroir pour optimiser l'espace et créer de la profondeur.
El efecto de espejo para optimizar el espacio y crear profundidad.

Espelho / Mirror



Gold Espelho / Mirror
Cromática Superbranco
Barra Stiletto Ouro



Mixstep White
Gold Espelho / Mirror
Cromática Jet

Espelho / Mirror

- 02** cores
colors
couleurs
colores
- 02** formatos
formats
formats
formatos
- 01** acabamento
finish
finition
acabado



Metallic

Espelho / Mirror

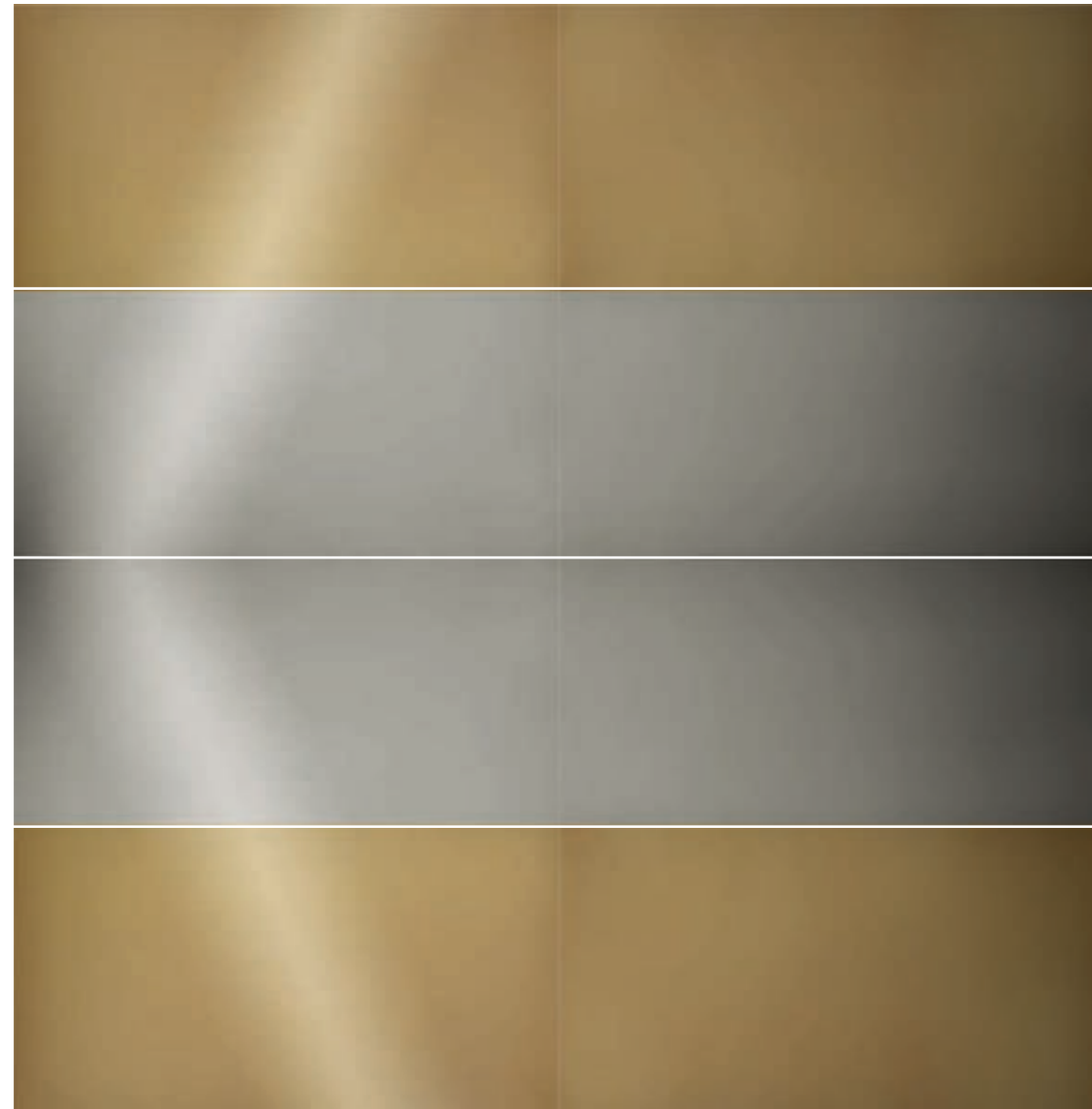

GRAPHIC VARIATION

Gold Espelho / Mirror

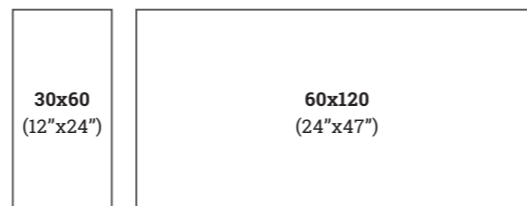

Peças - Pieces		Caixa - Box			Europaleta - Europallet			
	Espessura (mm) Thickness (mm)	Nº Peças No Pieces	M² Aprox. No of Sq. M. Approx.	Peso (Kg) Weight Kg	Nº Caixas No Boxes	M² Aprox. No of Sq. M. Approx.	Peso (Kg) Weight (Kg)	
30x60 cm	Rect.	± 8,0 ±5%	7	1.25	26.5	24	30.0	657
60x120 cm	Rect.	± 9,3 ±5%	1	0.72	16.9	40	28.8	697

Espelho / Mirror

ESPELHO / MIRROR

30x60	RECT	[29,6x59,2x0,80 cm]	P474	V2
60x120	RECT	[59,2x118,4x0,93 cm]	P494	V2

GOLD ESPELHO / MIRROR

30x60	RECT	[29,6x59,2x0,80 cm]	P474	V2
60x120	RECT	[59,2x118,4x0,93 cm]	P494	V2

Metallic

Produto para aplicação em revestimentos. Não pode ser aplicado em pavimento. Dado o efeito de espelho deste produto, não devem ser utilizados utensílios ou produtos de limpeza ácidos ou abrasivos, os quais poderão danificar a decoração metálica.

Product applicable on walls only; it cannot be used on floors. Avoid using acid or abrasive cleaning products or utensils that may damage the metal finish of the product.

Produit destiné au revêtement mural, à ne pas poser au sol. Pour préserver l'effet brillant miroir de ce produit, nous recommandons de ne pas utiliser des instruments ou des nettoyeurs acides ou abrasifs car ils peuvent endommager l'aspect métal.

Producto para aplicar en revestimientos. No se puede aplicar en el pavimento. Debido al efecto espejo de este producto, no se deben utilizar utensilios ni productos de limpieza ácidos o abrasivos, ya que podrían dañar la decoración metálica.



Reflexos dos metais mais nobres numa elegância discreta que permite criar ambientes requintados.
 Reflexes of the most noble metals in discrete elegance for creating refined environments.
Les reflets des métaux les plus nobles dans une élégance discrète qui permet de créer des ambiances raffinées.
 Reflejos de los metales más nobles en una elegancia discreta que permite crear ambientes refinados.



Vogue



Vogue Tabac

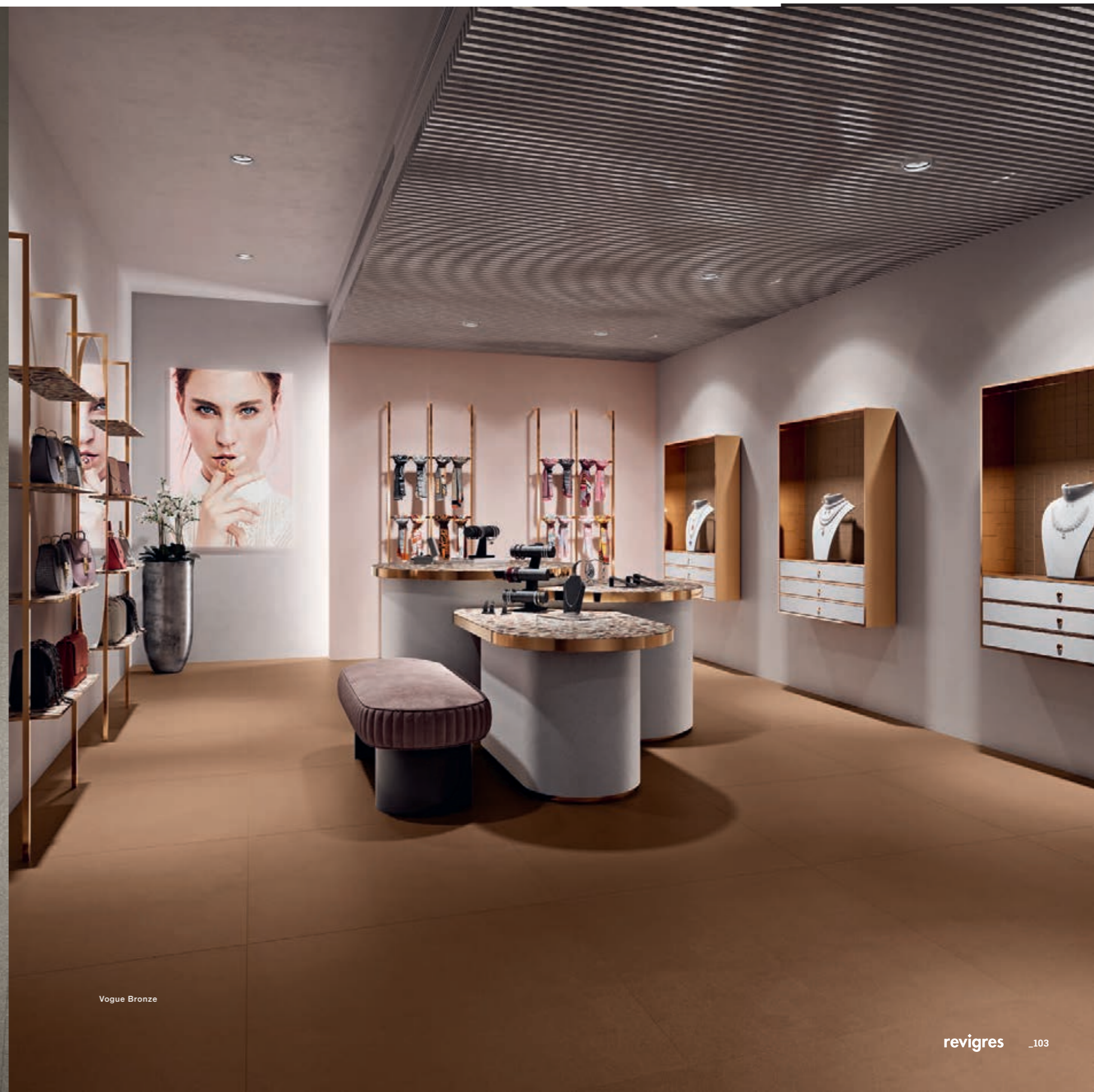

Vogue Bronze

NEW

Vogue

06 cores
couleurs
colores

04 formatos
formats
formatos

01 acabamento
finish
finition
acabado

- P
- V2
- 3
BLACK
BRONZE
TABAC
- 4
PERLA
SILVER
WHITE
- MATT RECT
Class 1
R10
- MATT RECT
A
- MATT RECT
DCOF
≥ 0,42

Metallic



ZOOM

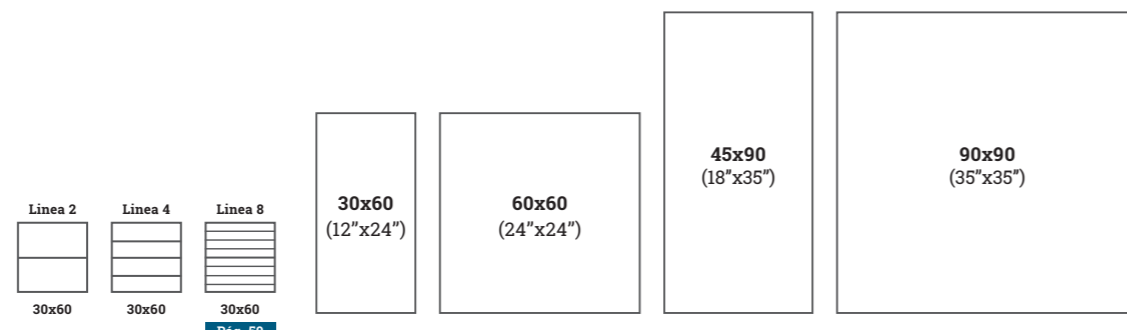

Tamanho	Acabamento	Espessura (mm) Thickness (mm)	Caixa - Box		Europaleta - Europallet			
			Nº Peças No Pieces	M² Aprox. No of Sq. M. Approx.	Peso (Kg) Weight Kg	Nº Caixas No Boxes	M² Aprox. No of Sq. M. Approx.	Peso (Kg) Weight (Kg)
30x60 cm	Matt Rect	± 8,5 ±5%	5	0.90	18.0	60	54.00	1101
60x60 cm	Matt Rect	± 8,5 ±5%	4	1.44	28.7	36	51.84	1 053
90x90 cm	Matt Rect	± 10,5 ±0,5 mm	2	1.62	39.0	24	38.88	991
45x90 cm	Matt Rect	± 10,5 ±0,5 mm	4	1.62	39.0	27	43.74	1 074

Vogue



Metallic

Vogue Silver
Vogue Perla



Metallic

Metallic

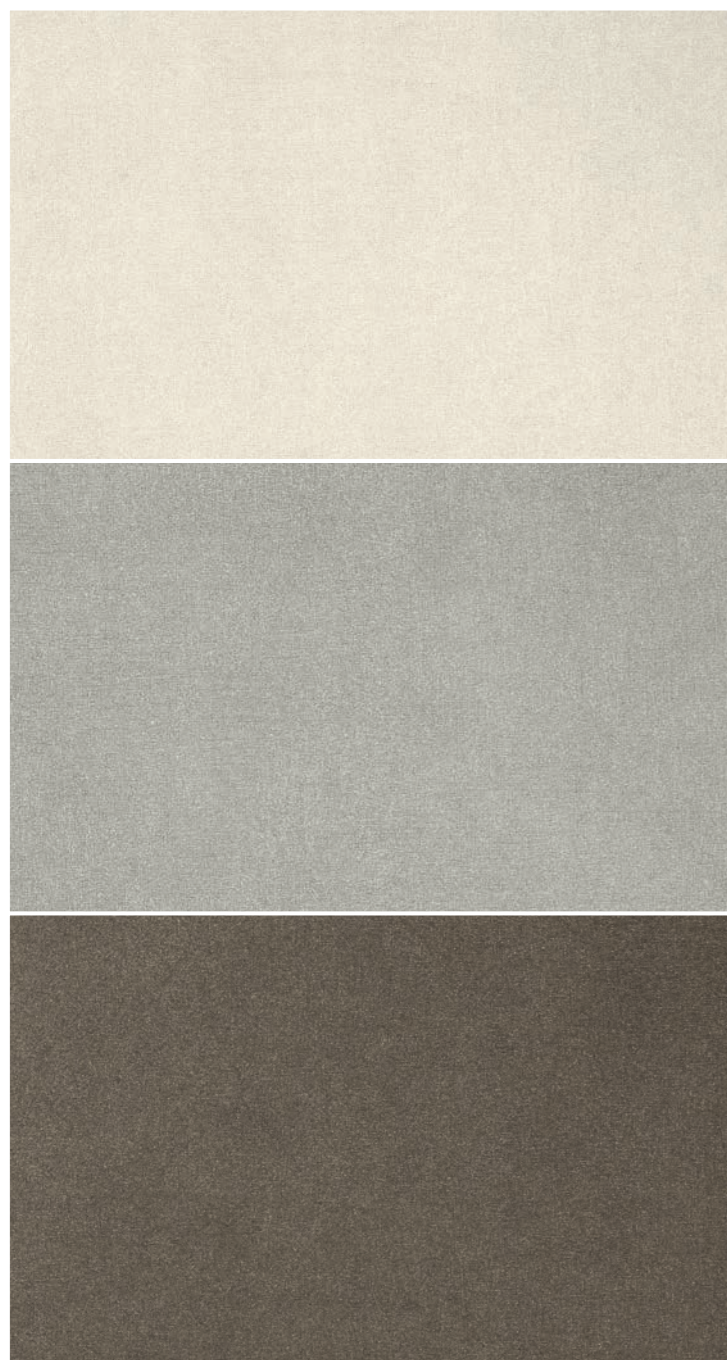

VOGUE WHITE

30x60	MATT RECT	[29,6x59,2x0,85 cm]	P103	V2	4	class 1	A	R10	≥0,42
60x60	MATT RECT	[59,2x59,2x0,85 cm]	P103	V2	4	class 1	A	R10	≥0,42
45x90	MATT RECT	[44,5x89,0x1,05 cm]	P123	V2	4	class 1	A	R10	≥0,42
90x90	MATT RECT	[89,0x89,0x1,05 cm]	P123	V2	4	class 1	A	R10	≥0,42

VOGUE SILVER

30x60	MATT RECT	[29,6x59,2x0,85 cm]	P103	V2	4	class 1	A	R10	≥0,42
60x60	MATT RECT	[59,2x59,2x0,85 cm]	P103	V2	4	class 1	A	R10	≥0,42
45x90	MATT RECT	[44,5x89,0x1,05 cm]	P123	V2	4	class 1	A	R10	≥0,42
90x90	MATT RECT	[89,0x89,0x1,05 cm]	P123	V2	4	class 1	A	R10	≥0,42

VOGUE TABAC

30x60	MATT RECT	[29,6x59,2x0,85 cm]	P103	V2	3	class 1	A	R10	≥0,42
60x60	MATT RECT	[59,2x59,2x0,85 cm]	P103	V2	3	class 1	A	R10	≥0,42
45x90	MATT RECT	[44,5x89,0x1,05 cm]	P123	V2	3	class 1	A	R10	≥0,42
90x90	MATT RECT	[89,0x89,0x1,05 cm]	P123	V2	3	class 1	A	R10	≥0,42

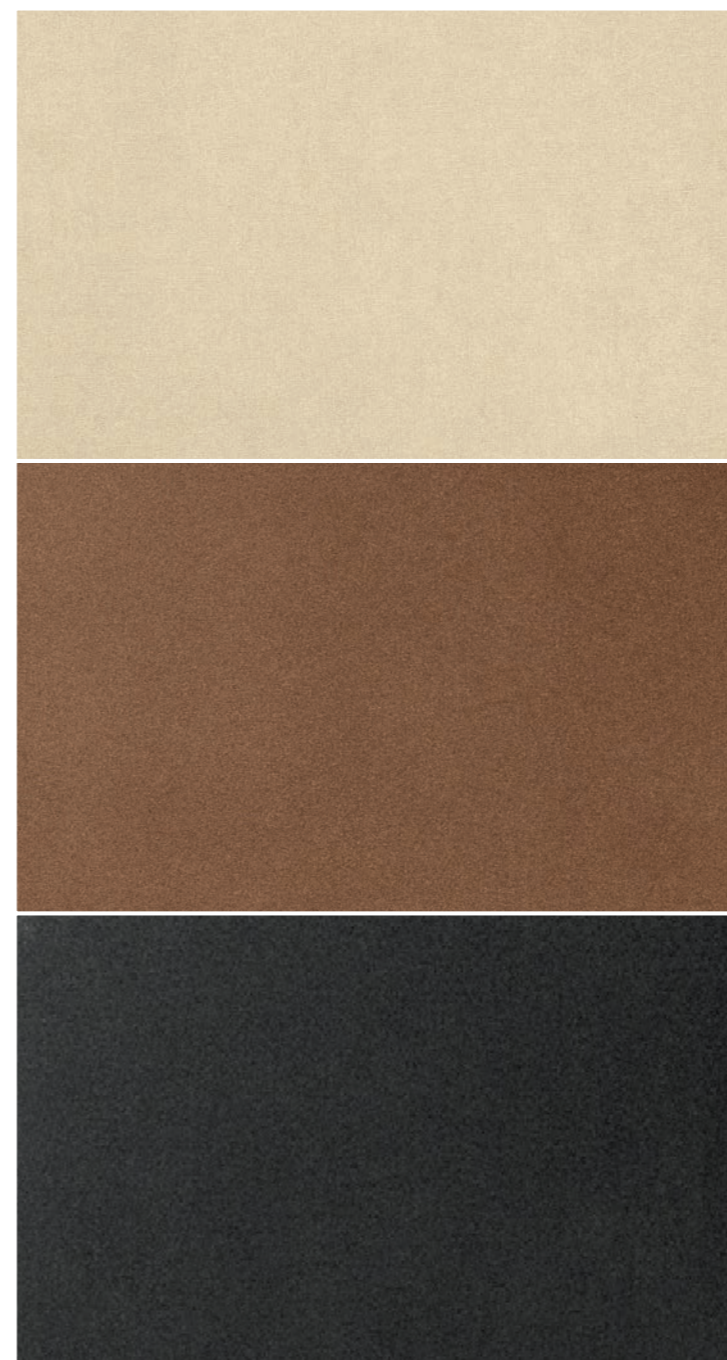

VOGUE PERLA

30x60	MATT RECT	[29,6x59,2x0,85 cm]	P103	V2	4	class 1	A	R10	≥0,42
60x60	MATT RECT	[59,2x59,2x0,85 cm]	P103	V2	4	class 1	A	R10	≥0,42
45x90	MATT RECT	[44,5x89,0x1,05 cm]	P123	V2	4	class 1	A	R10	≥0,42
90x90	MATT RECT	[89,0x89,0x1,05 cm]	P123	V2	4	class 1	A	R10	≥0,42

VOGUE BRONZE

30x60	MATT RECT	[29,6x59,2x0,85 cm]	P103	V2	3	class 1	A	R10	≥0,42
60x60	MATT RECT	[59,2x59,2x0,85 cm]	P103	V2	3	class 1	A	R10	≥0,42
45x90	MATT RECT	[44,5x89,0x1,05 cm]	P123	V2	3	class 1	A	R10	≥0,42
90x90	MATT RECT	[89,0x89,0x1,05 cm]	P123	V2	3	class 1	A	R10	≥0,42

VOGUE BLACK

30x60	MATT RECT	[29,6x59,2x0,85 cm]	P103	V2	3	class 1	A	R10	≥0,42
60x60	MATT RECT	[59,2x59,2x0,85 cm]	P103	V2	3	class 1	A	R10	≥0,42
45x90	MATT RECT	[44,5x89,0x1,05 cm]	P123	V2	3	class 1	A	R10	≥0,42
90x90	MATT RECT	[89,0x89,0x1,05 cm]	P123	V2	3	class 1	A	R10	≥0,42

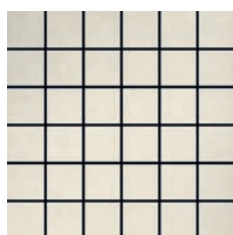

STRATUS 36
VOGUE WHITE (a) (f)
30x30 P19 /peça_piece



STRATUS 36
VOGUE SILVER (a) (f)
30x30 P19 /peça_piece



STRATUS 36
VOGUE TABAC (a) (f)
30x30 P19 /peça_piece

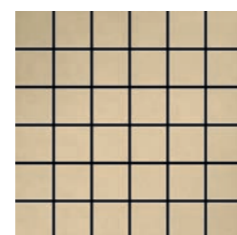

STRATUS 36
VOGUE PERLA (a) (f)
30x30 P19 /peça_piece



STRATUS 36
VOGUE BRONZE (a) (f)
30x30 P19 /peça_piece

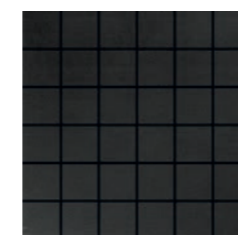

STRATUS 36
VOGUE BLACK (a) (f)
30x30 P19 /peça_piece

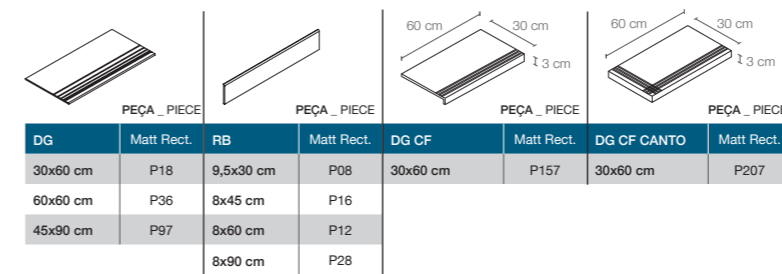

DG CF / DG CF Canto: Peças produzidas sob encomenda.
 DG CF / DG CF Canto: Pieces produced on order.
 DG CF / DG CF Canto: Pièces produites sur commande
 DG CF / DG CF Canto: Piezas producidas por encargo

DG CF Canto: Disponível em canto esquerdo e direito.
 DG CF Canto: Available in left and right corner.
 DG CF Canto: Disponible en angle gauche et droit.
 DG CF Canto: Canto izquierdo y derecho disponibles.

Tons metalizados, para ambientes modernos.
Metallic tint for modern environments.
Des tons métallisés pour des environnements modernes.
Tonos metalizados, para ambientes modernos.

Iron _ Copper



Copper
Step Copper
Exotic Âmbar



Iron
Step Iron

Iron _ Copper

- 02** cores
colors
couleurs
colores
- 03** formatos
formats
formats
formatos
- 01** acabamento
finish
finition
acabado



Iron



GRAPHIC VARIATION

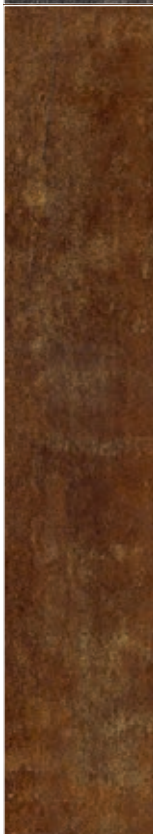

Copper

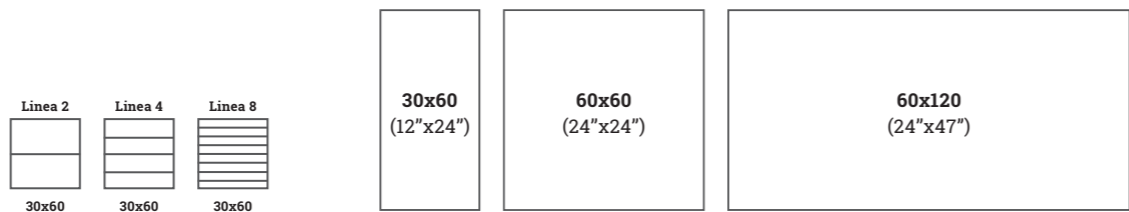

Peças / Pieces	Espessura (mm) / Thickness (mm)	Caixa / Box			Europalet / Europallet		
		Nº Peças / No Pieces	M² Aprox. / No of Sq. M. Approx.	Peso (Kg) / Weight Kg	Nº Caixas / No Boxes	M² Aprox. / No of Sq. M. Approx.	Peso (Kg) / Weight (Kg)
30x60 cm	Nat.	5	0.90	18.0	48	43.20	885
	Rect.	5	0.90	18.0	60	54.00	1 101
60x60 cm	Rect.	4	1.44	28.7	36	51.84	1 053
60x120 cm	Rect.	2	1.44	33.0	30	43.20	1 011

Iron _ Copper





IRON

60x120	RECT	[59,2x118,4x0,98 cm]	P139	V3	↕ 3
30x60	NAT	[...x0,85 cm]	P85	V3	↕ 3
30x60	RECT	[29,6x59,2x0,85 cm]	P95	V3	↕ 3



IRON

60x60	RECT	[59,2x59,2x0,85 cm]	P111	V3	↕ 3
-------	------	-----------------------	------	----	-----



STEP IRON (a)
30x30 P29 /peça_pieza



STEP SILVER (a)
30x30 P97 /peça_pieza



TALISMAN IRON (a)
30x30 P47 /peça_pieza



METALIST IRON (a)
30x60 RECT [29,6x59,2 cm] P91 /peça_pieza



COPPER

60x120	RECT	[59,2x118,4x0,98 cm]	P139	V3	↕ 3
30x60	NAT	[...x0,85 cm]	P85	V3	↕ 3
30x60	RECT	[29,6x59,2x0,85 cm]	P95	V3	↕ 3



COPPER

60x60	RECT	[59,2x59,2x0,85 cm]	P111	V3	↕ 3
-------	------	-----------------------	------	----	-----



STEP COPPER (a)
30x30 P29 /peça_pieza

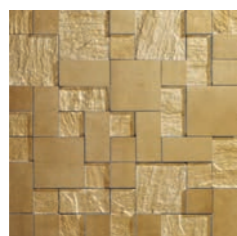

STEP GOLD (a)
30x30 P97 /peça_pieza



COLUNATTA 3 COPPER (a)
30x30 P48 /peça_pieza



METALIST COPPER (a)
30x60 RECT [29,6x59,2 cm] P91 /peça_pieza



Iron

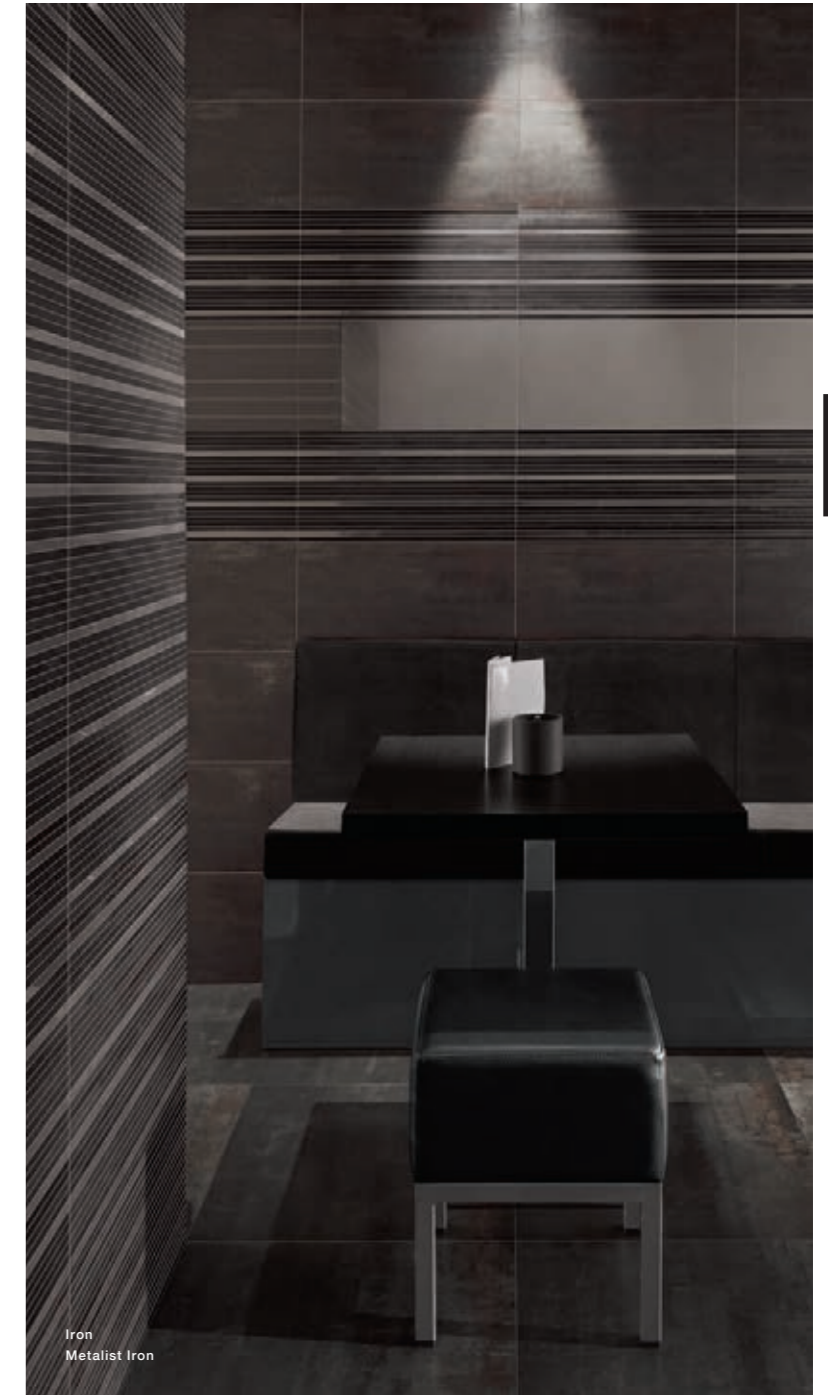

Iron
Metalist Iron

PEÇA _ PIECE		PEÇA _ PIECE		PEÇA _ PIECE		PEÇA _ PIECE	
DG	Nat	Rect	RB	Nat	Rect	DG CF	Rect.
30x30 cm	P08	P10	9,5x30 cm	P07	P08	30x60 cm	P157
30x60 cm	P12	P18	8x60 cm	P10	P12		
60x60 cm	-	P36	8x120 cm	-	P28		
30x120 cm	-	P97					
60x120 cm	-	P167					

DG CF / DG CF Canto: Peças produzidas sob encomenda.
 DG CF / DG CF Canto: Pieces produced on order.
 DG CF / DG CF Canto: Pièces produites sur commande
 DG CF / DG CF Canto: Piezas producidas por encargo

DG CF Canto: Disponível em canto esquerdo e direito.
 DG CF Canto: Available in left and right corner.
 DG CF Canto: Disponible en angle gauche et droit.
 DG CF Canto: Canto izquierdo y derecho disponibles.

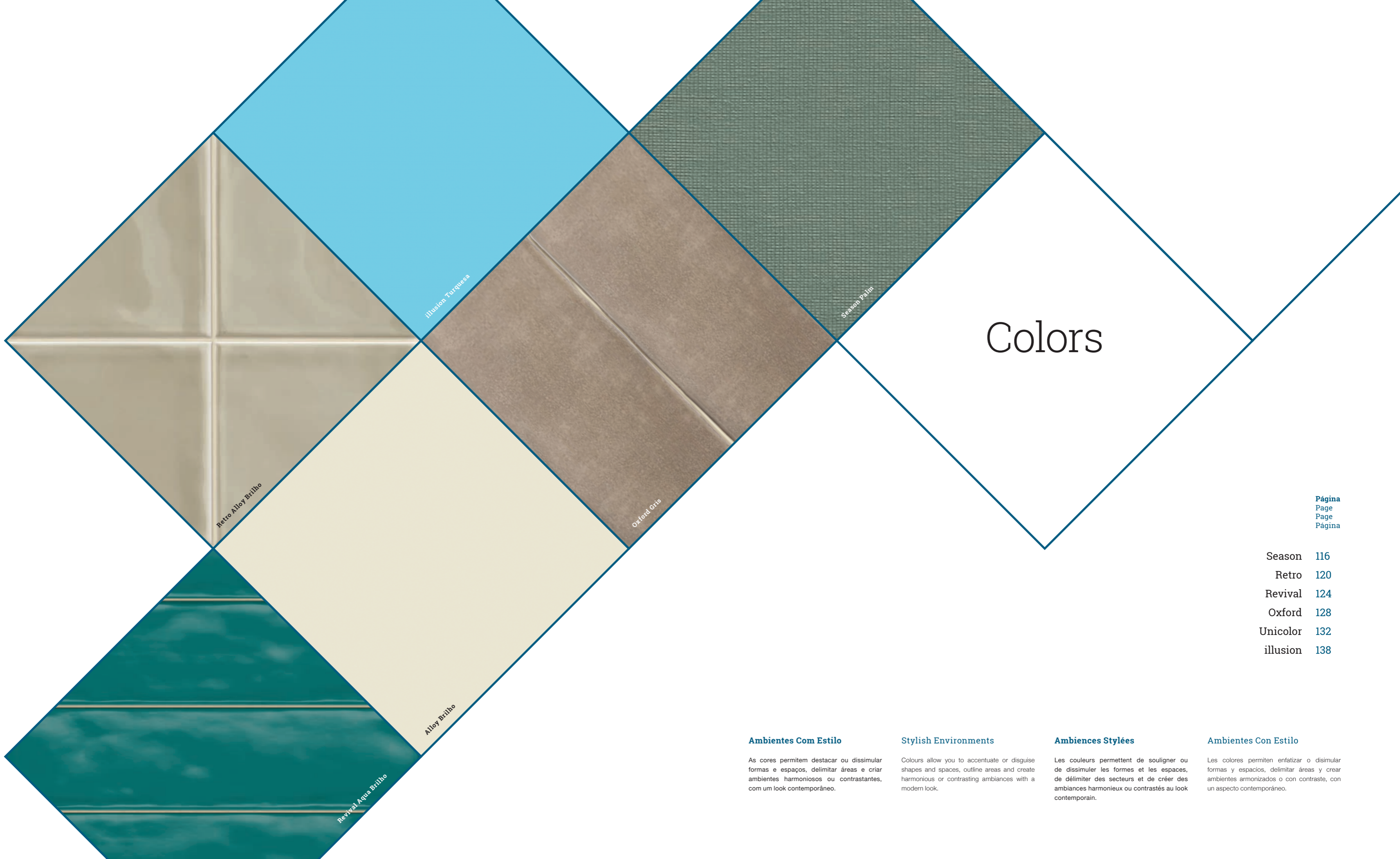

Colors

Página
Page
Page
Página

Season	116
Retro	120
Revival	124
Oxford	128
Unicolor	132
illusion	138

Ambientes Com Estilo

As cores permitem destacar ou dissimular formas e espaços, delimitar áreas e criar ambientes harmoniosos ou contrastantes, com um look contemporâneo.

Stylish Environments

Colours allow you to accentuate or disguise shapes and spaces, outline areas and create harmonious or contrasting ambiances with a modern look.

Ambientes Stylées

Les couleurs permettent de souligner ou de dissimuler les formes et les espaces, de délimiter des secteurs et de créer des ambiances harmonieuses ou contrastées au look contemporain.

Ambientes Con Estilo

Los colores permiten enfatizar o disimular formas y espacios, delimitar áreas y crear ambientes armonizados o con contraste, con un aspecto contemporáneo.



Cores e texturas que recriam o efeito do têxtil e promovem ambientes envolventes que apelam a novas sensações.
 Colours and textures that recreate the textile effect and foster immersive environments that arouse new sensations.
Des couleurs et des textures qui reproduisent l'effet du textile et promeuvent des ambiances qui invitent à de nouvelles sensations.
 Colores y texturas que recrean el efecto del tejido y crean ambientes envolventes que evocan nuevas sensaciones.



Season



Season Palm
 Season Luna
 Nordik Nut



Season Lava
 Season Quartz
 Midseason Quartz
 Nordik Nut

Season

07 cores
colors
couleurs
colores

01 formato
format
format
formato

01 acabamento
finish
finition
acabado



Season

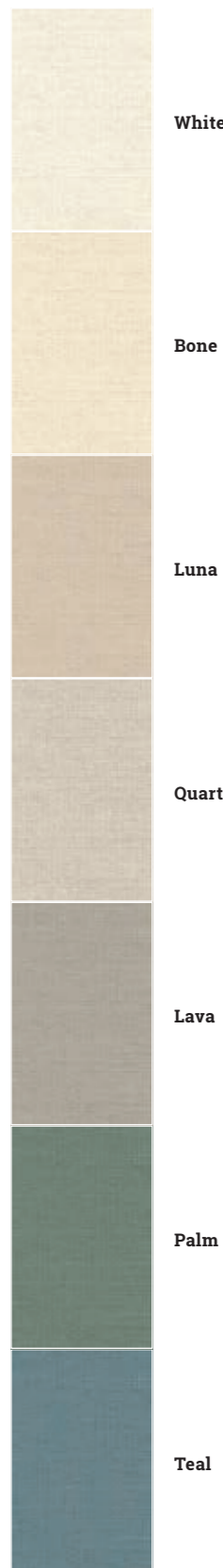
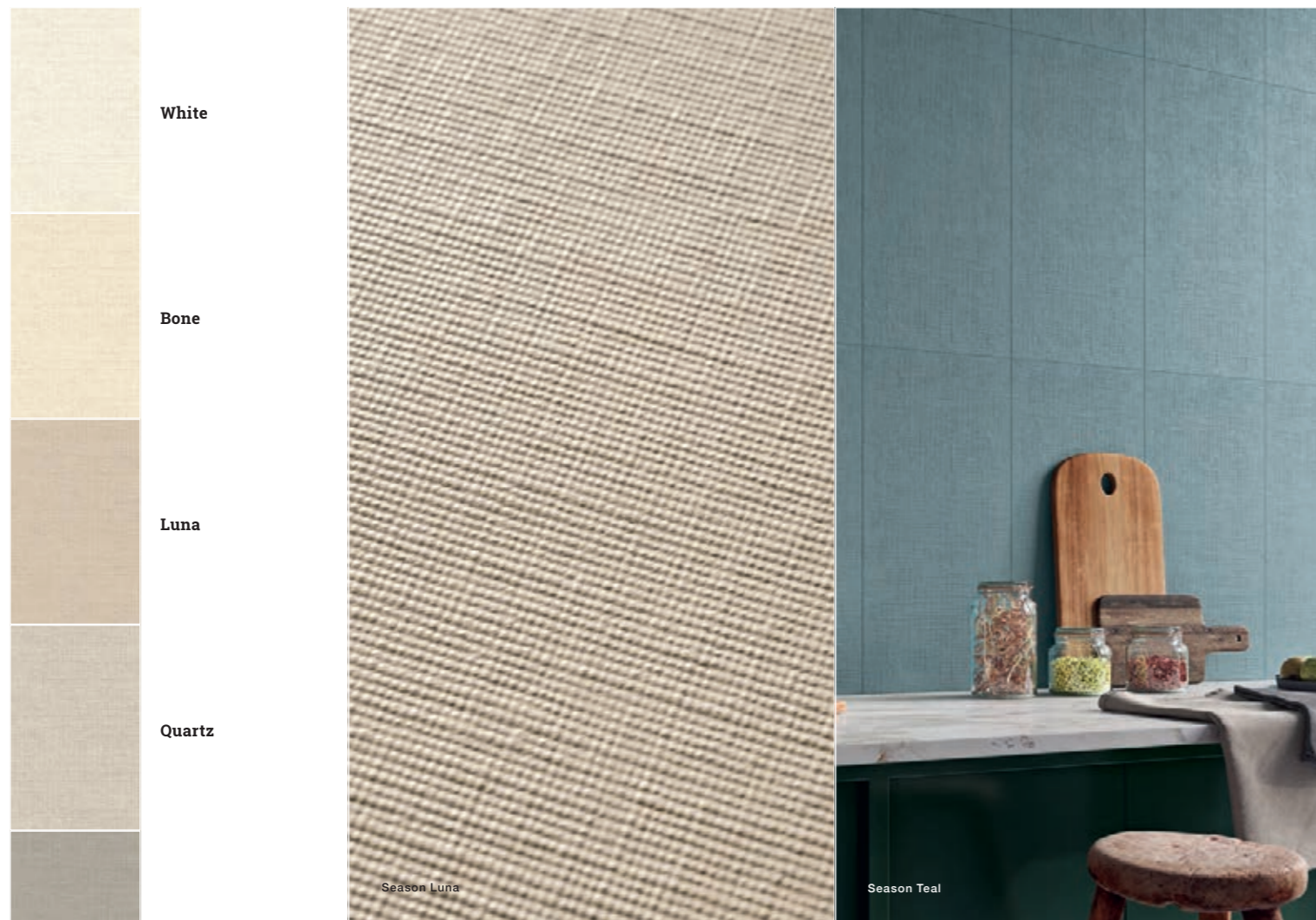

ZOOM

30x60
(12"x24")

Peças / Pieces		Caixa / Box			Europaleta / Europallet			
30x60 cm	Rect.	Espesura (mm) Thickness (mm)	Nº Peças No Pieces	M² Aprox. No of Sq. M. Approx.	Peso (Kg) Weight Kg	Nº Caixas No Boxes	M² Aprox. No of Sq. M. Approx.	Peso (Kg) Weight (Kg)
30x60 cm	Rect.	± 0,0 ± 5 %	5	0.9	14.5	72	64.8	1 065

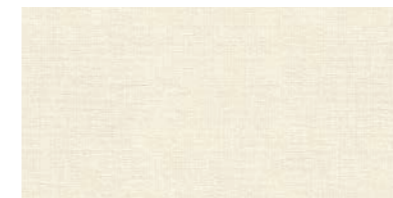

SEASON WHITE
30x60 RECT [29,6x59,2x0,90 cm] P77

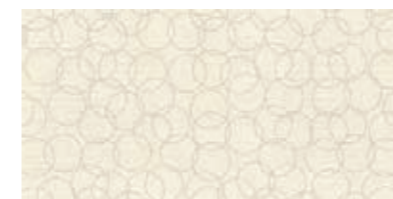

MIDSEASON WHITE
30x60 RECT [29,6x59,2x0,90 cm] P33 /peça_piece

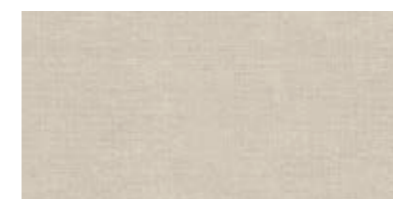

SEASON QUARTZ
30x60 RECT [29,6x59,2x0,90 cm] P77

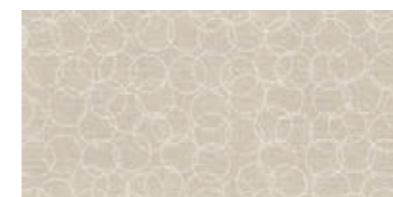

MIDSEASON QUARTZ
30x60 RECT [29,6x59,2x0,90 cm] P33 /peça_piece



SEASON TEAL
30x60 RECT [29,6x59,2x0,90 cm] P77



MIDSEASON TEAL
30x60 RECT [29,6x59,2x0,90 cm] P33 /peça_piece

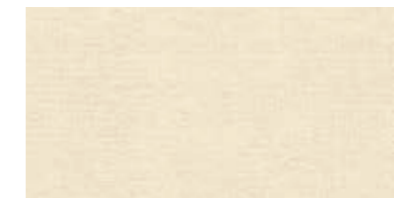

SEASON BONE
30x60 RECT [29,6x59,2x0,90 cm] P77

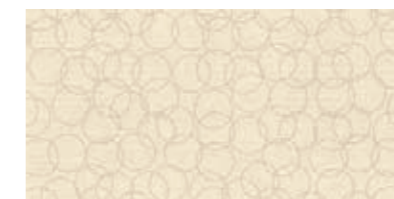

MIDSEASON BONE
30x60 RECT [29,6x59,2x0,90 cm] P33 /peça_piece



SEASON LAVA
30x60 RECT [29,6x59,2x0,90 cm] P77

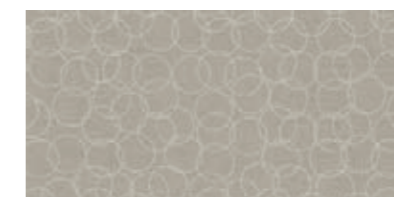

MIDSEASON LAVA
30x60 RECT [29,6x59,2x0,90 cm] P33 /peça_piece

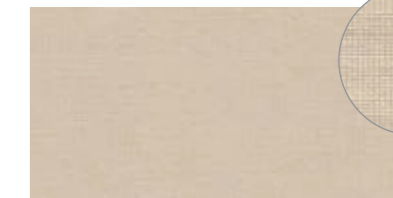

SEASON LUNA
30x60 RECT [29,6x59,2x0,90 cm] P77

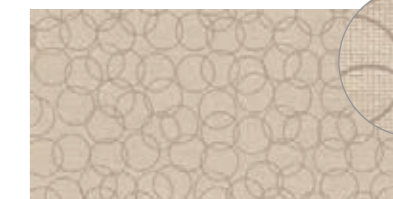

MIDSEASON LUNA
30x60 RECT [29,6x59,2x0,90 cm] P33 /peça_piece



SEASON PALM
30x60 RECT [29,6x59,2x0,90 cm] P77



MIDSEASON PALM
30x60 RECT [29,6x59,2x0,90 cm] P33 /peça_piece



PASSARELLE WHITE (a)
30x30 P21 /peça_piece
Season: White, Bone, Luna, Lava



PASSARELLE PALM (a)
30x30 P21 /peça_piece
Season: Bone, Luna, Palm



PASSARELLE TEAL (a)
30x30 P21 /peça_piece
Season: Quartz, Lava, Teal

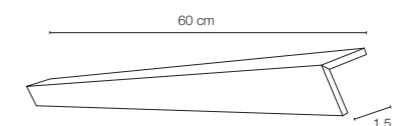

PERFIL SEASON
1,5x60 RECT [1,5x59,2x0,90 cm] P32 /peça_piece

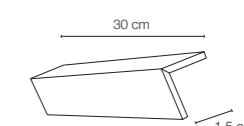

PERFIL SEASON
1,5x30 RECT [1,5x29,6x0,90 cm] P20 /peça_piece

Perfil: Peças produzidas sob encomenda
Perfil: Pieces produced on order.
Perfil: Pièces produites sur commande.
Perfil: Piezas producidas por encargo.



Uma retrospectiva moderna do mosaico em pequeno formato, com brilhos e cores vibrantes.
 A modern revival of the small format tile, with shine and vibrant colours.
 Une rétrospective moderne du carrelage de petit format, aux reflets lumineux et aux couleurs vibrantes.
 Una retrospectiva moderna del mosaico en pequeño formato, con brillos y colores vibrantes.



Retro



Retro Aqua
 Retro White
 Cityzen Carbon



Retro Olive
 Revival Alloy
 Urban Antracite

09 cores
colors
couleurs
colores

01 formato
format
format
formato

01 acabamento
finish
finition
acabado

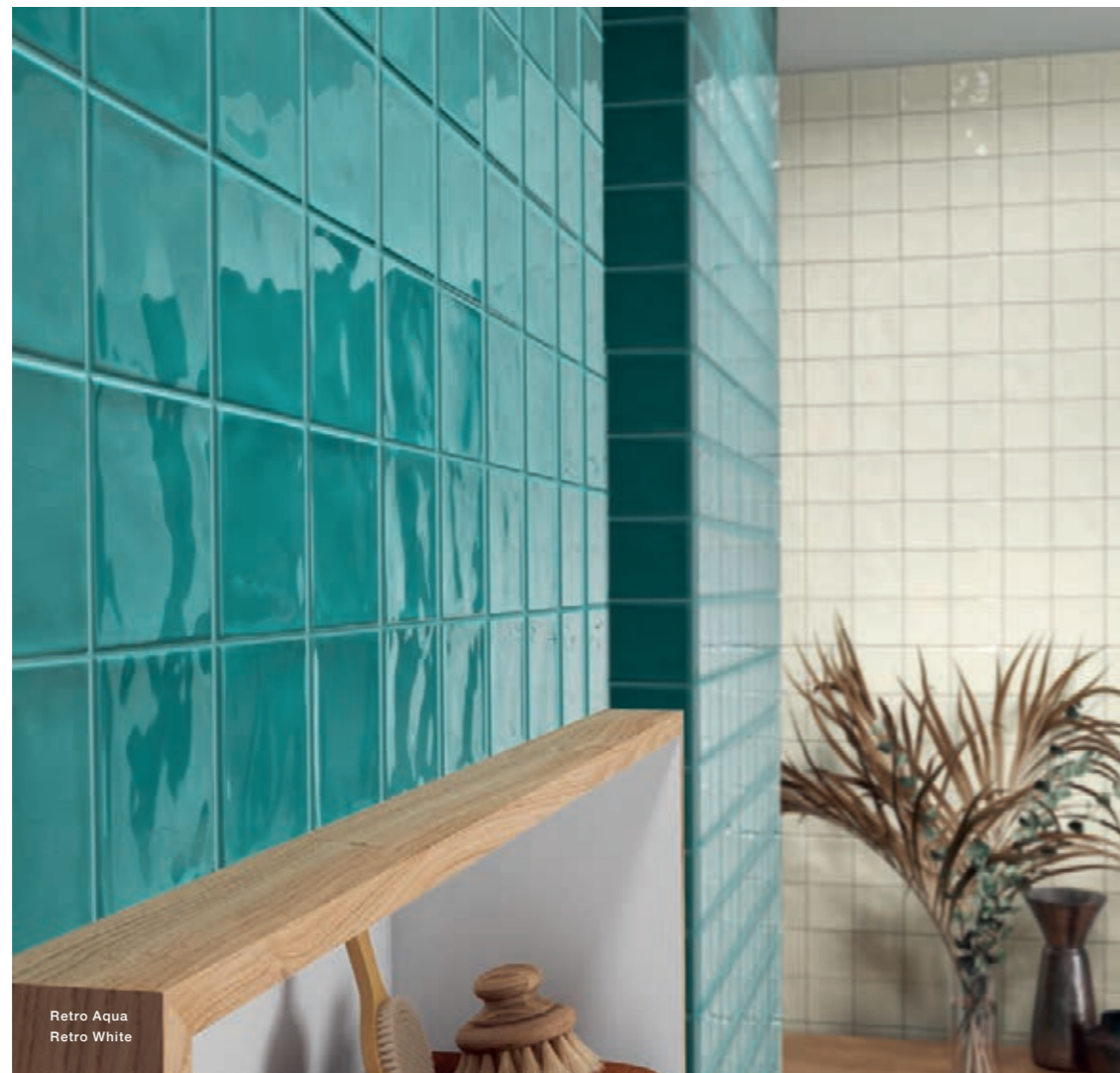

Retro Aqua
Retro White



20x40
(8"x16")

Peças / Pieces		Caixa / Box			Europaleta / Europallet			
20x40 cm	Nat.	Espessura (mm) Thickness (mm)	Nº Peças No Pieces	M² Aprox. No of Sq. M. Approx.	Peso (Kg) Weight Kg	Nº Caixas No Boxes	M² Aprox. No of Sq. M. Approx.	Peso (Kg) Weight (Kg)
		± 9,0 ± 5 %	10	0,8	11,5	96	76,8	1 120



RETRO WHITE BRILHO
20x40 NAT [...x0,90 cm] P72



RETRO ALLOY BRILHO
20x40 NAT [...x0,90 cm] P72



RETRO BEGE BRILHO
20x40 NAT [...x0,90 cm] P72



RETRO ROSE BRILHO
20x40 NAT [...x0,90 cm] P72

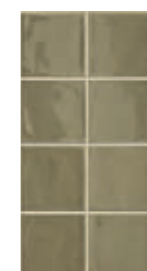

RETRO OLIVE BRILHO
20x40 NAT [...x0,90 cm] P72



RETRO MUSTARD BRILHO
20x40 NAT [...x0,90 cm] P72



RETRO AQUA BRILHO
20x40 NAT [...x0,90 cm] P72



RETRO BLUE BRILHO
20x40 NAT [...x0,90 cm] P72

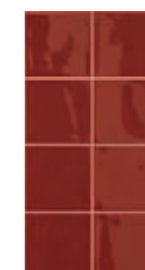

RETRO CARMIM BRILHO
20x40 NAT [...x0,90 cm] P84

Devido às características deste produto, recomenda-se a betumação dos pré-cortes das peças.
Due to the characteristics of the product, grouting of the pre-cut tiles is advisable.
En raison des caractéristiques de ce produit, il est recommandé de sceller les prédécoupes des carreaux.
Debido a las características de este producto, se recomienda el rejuntado de los precortes de las piezas.

Dado o efeito deste produto, as peças devem ser aplicadas sempre no mesmo sentido.
Given the effect of the product, tiles must always be laid out facing same direction.
En raison de l'effet de ce produit, les carreaux doivent toujours être posés dans le même sens.
Dado el efecto de este producto, las piezas deben aplicarse siempre en el mismo sentido.

O regresso do mosaico tradicional com brilho e cores contemporâneas.
The return of the traditional tile with shine and contemporary colours.
Le retour du carreau traditionnel avec luminosité et les couleurs contemporaines.
El regreso del mosaico tradicional con brillos y con colores contemporâneos.

Revival



Revival Olive
Revival Bege
Urban Offwhite
Hydraulik Offwhite



Revival Mustard
Forest Nude

Revival

09 cores
colors
couleurs
colores

01 formato
format
format
formato

01 acabamento
finish
finition
acabado

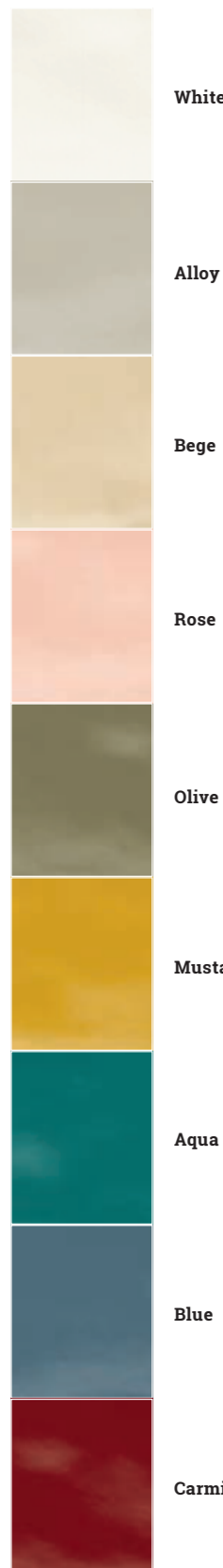

Revival White



30x45
(12"x18")

Peças / Pieces		Caixa / Box			Europaleta / Europallet			
30x45 cm	Nat.	Espessura (mm) Thickness (mm)	Nº Peças No Pieces	M² Aprox. No of Sq. M. Approx.	Peso (Kg) Weight Kg	Nº Caixas No Boxes	M² Aprox. No of Sq. M. Approx.	Peso (Kg) Weight (Kg)
30x45 cm	Nat.	± 9,0 ± 5 %	11	1.5	23.9	48	72	1 166

Revival



REVIVAL WHITE BRILHO
30x45 NAT [...x0,90 cm] P72

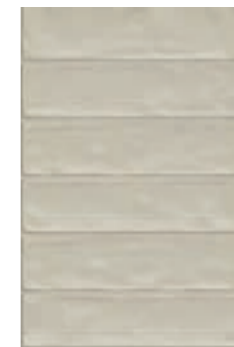

REVIVAL ALLOY BRILHO
30x45 NAT [...x0,90 cm] P72

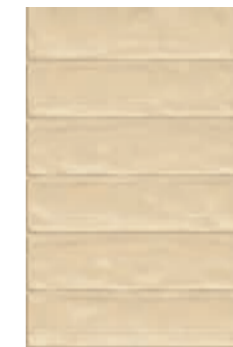

REVIVAL BEGE BRILHO
30x45 NAT [...x0,90 cm] P72

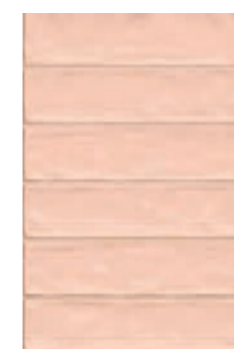

REVIVAL ROSE BRILHO
30x45 NAT [...x0,90 cm] P72



REVIVAL OLIVE BRILHO
30x45 NAT [...x0,90 cm] P72



REVIVAL MUSTARD BRILHO
30x45 NAT [...x0,90 cm] P72



REVIVAL AQUA BRILHO
30x45 NAT [...x0,90 cm] P72



REVIVAL BLUE BRILHO
30x45 NAT [...x0,90 cm] P72



REVIVAL CARMIM BRILHO
30x45 NAT [...x0,90 cm] P84

Devido às características deste produto, recomenda-se a betumação dos pré-cortes das peças.
Due to the characteristics of the product, grouting of the pre-cut tiles is advisable.
En raison des caractéristiques de ce produit, il est recommandé de sceller les prédécoupes des carreaux.
Debido a las características de este producto, se recomienda el rejuntado de los precortes de las piezas.

Dado o efeito deste produto, as peças devem ser aplicadas sempre no mesmo sentido.
Given the effect of the product, tiles must always be laid out facing same direction.
En raison de l'effet de ce produit, les carreaux doivent toujours être posés dans le même sens.
Dado el efecto de este producto, las piezas deben aplicarse siempre en el mismo sentido.

Revestimentos com reflexos do azulejo tradicional.
Wall tiles with traditional tile reflections.
Revêtements murales avec les reflets du carreau traditionnel.
Revestimientos que recuerdan al azulejo tradicional.

Oxford



Oxford Carmim
Oxford Offwhite
Oxford Black

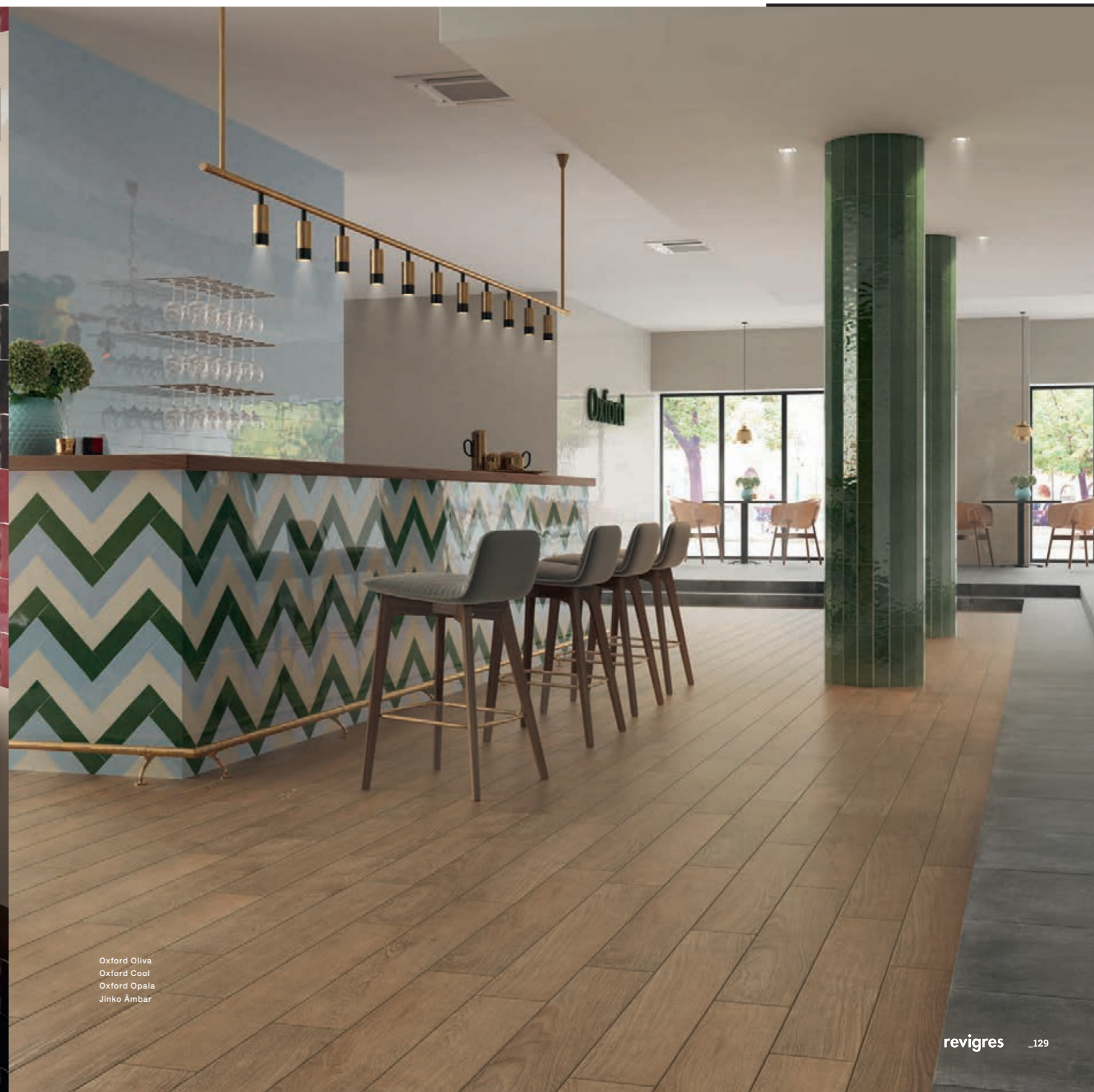

Oxford Oliva
Oxford Cool
Oxford Opala
Jinko Âmbar

09 cores
couleurs
colores

01 formato
format
formato

01 acabamento
finish
finition
acabado

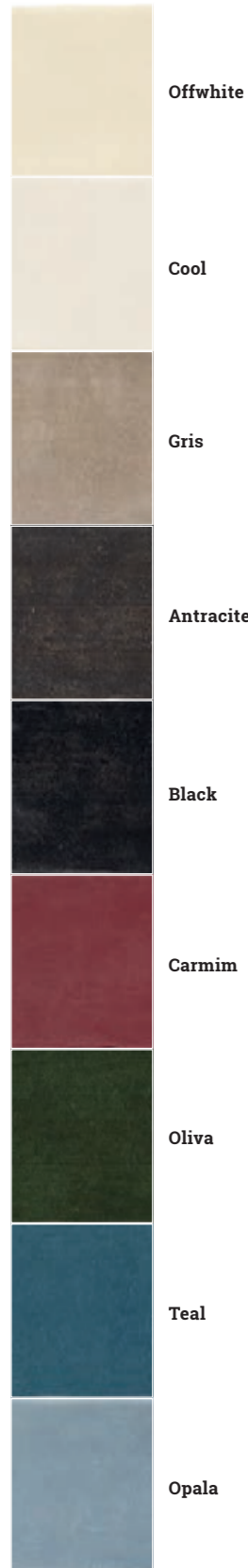

Oxford Cool

7,5x30
(3"x12")

Pecas / Pieces		Caixa / Box			Europaleta / Europallet			
Espessura (mm) Thickness (mm)	Nº Peças No Pieces	M² Aprox. No of Sq. M. Approx.	Peso (Kg) Weight Kg	Nº Caixas No Boxes	M² Aprox. No of Sq. M. Approx.	Peso (Kg) Weight (Kg)		
7,5x30 cm	Nat.	± 9,0 ± 5 %	40	0,9	14	66	59,4	945

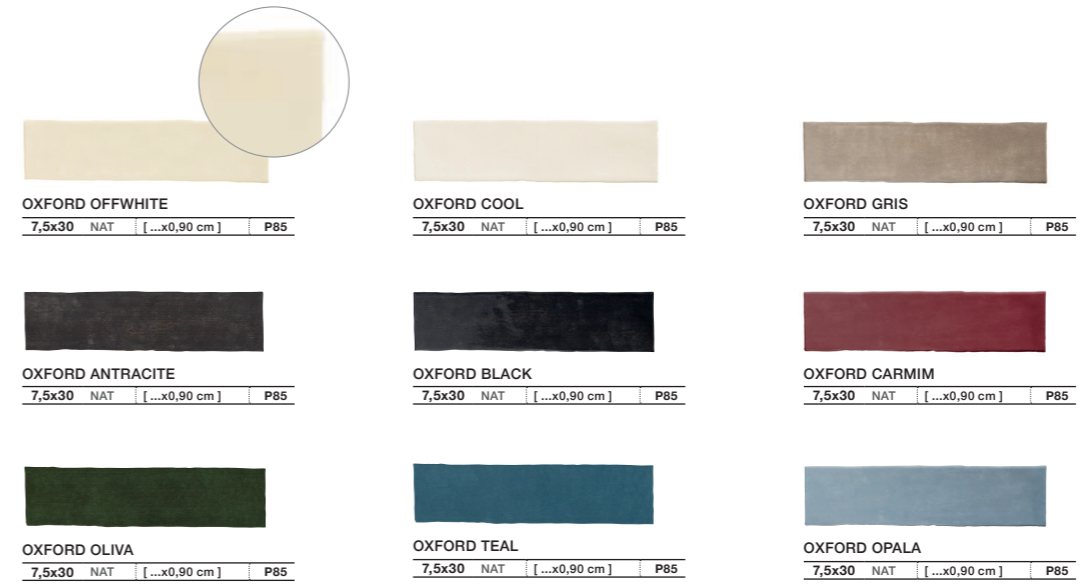

Oxford Cool
Oxford Gris
Oxford Antracite
Oxford Black

Mil e uma cores. Para ambientes arrojadados ou espaços mais neutros.
Thousand and one colours. For bold environments or more neutral spaces.
Mille et une couleurs. Pour les ambiances audacieuses ou les espaces plus neutres.
Mil y un colores. Para ambientes atrevidos o espacios más neutros.

Unicolor



Branco Oriente
Chess Vermelho
Urban Gris



Branco Mate
Urban Gris

06 cores
colors
couleurs
colores

04 formatos
formats
formats
formatos

02 acabamentos
finishes
finitions
acabados



White Cool

Branco Oriente

Branco Mate

Marfim

Marfim Brilho

Alloy Brilho

Iron Brilho

Preto Brilho

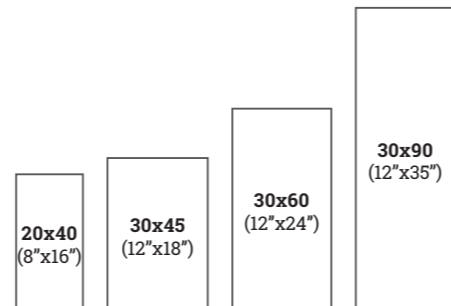

Peças / Pieces		Caixa / Box			Europaleta / Europallet			
		Espessura (mm) Thickness (mm)	Nº Peças No of Pieces	M² Aprox. No of Sq. M. Approx.	Peso (Kg) Weight Kg	Nº Caixas No Boxes	M² Aprox. No of Sq. M. Approx.	Peso (Kg) Weight (Kg)
20x40 cm	Nat.	± 8,4 ± 5 %	10	0.80	11.5	96	76.8	1 120
30x45 cm	Nat.	± 9,0 ± 5 %	11	1.50	23.9	48	72.0	1 166
30x60 cm	Nat.	± 9,0 ± 5 %	5	0.90	15.0	72	64.8	1 101
	Rect.	± 9,0 ± 5 %	5	0.90	14.5	72	64.8	1 065
30x90 cm	Rect.	± 12,3 ± 0,5 mm	4	1.08	22.0	40	43.2	901



BRANCO ORIENTE

30x90	RECT	[29,6x88,8x1,23 cm]	P88
	NAT	[...x0,90 cm]	P64
30x60	RECT	[29,6x59,2x0,90 cm]	P75
30x45	NAT	[...x0,90 cm]	P62
20x40	NAT	[...x0,84 cm]	P60

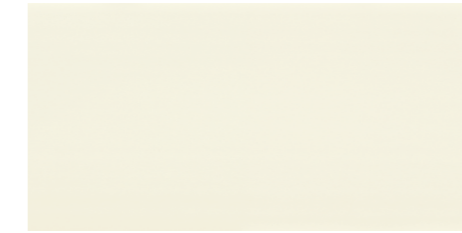

MARFIM BRILHO

30x90	RECT	[29,6x88,8x1,23 cm]	P88
	NAT	[...x0,90 cm]	P64
30x60	RECT	[29,6x59,2x0,90 cm]	P75



ALLOY BRILHO

30x60	NAT	[...x0,90 cm]	P66
	RECT	[29,6x59,2x0,90 cm]	P77



BRANCO MATE

30x90	RECT	[29,6x88,8x1,23 cm]	P88
30x60	NAT	[...x0,90 cm]	P64
	RECT	[29,6x59,2x0,90 cm]	P75
30x45	NAT	[...x0,90 cm]	P62
20x40	NAT	[...x0,84 cm]	P60

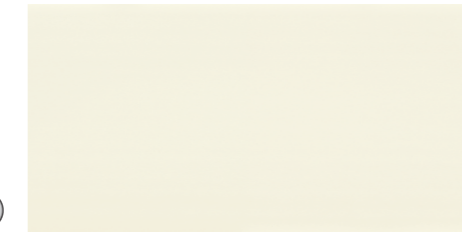

MARFIM

30x90	RECT	[29,6x88,8x1,23 cm]	P88
30x60	NAT	[...x0,90 cm]	P64
	RECT	[29,6x59,2x0,90 cm]	P75



IRON BRILHO

30x60	NAT	[...x0,90 cm]	P66
	RECT	[29,6x59,2x0,90 cm]	P77

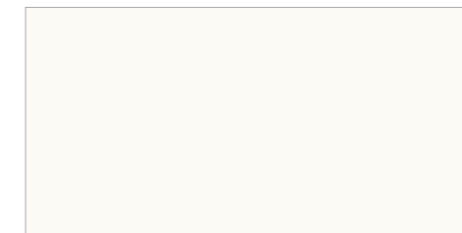

WHITE COOL

30x90	RECT	[29,6x88,8x1,23 cm]	P88
30x60	NAT	[...x0,90 cm]	P64
	RECT	[29,6x59,2x0,90 cm]	P75



PRETO BRILHO

30x60	NAT	[...x0,90 cm]	P66
	RECT	[29,6x59,2x0,90 cm]	P77

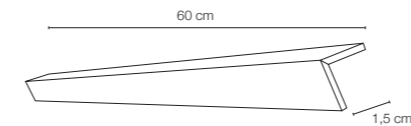

PERFIL

1,5x60	RECT	[1,5x59,2x0,90 cm]	P32 /peça_piece
--------	------	----------------------	-----------------

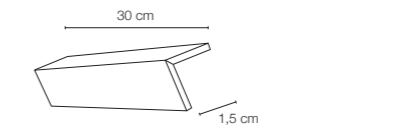

PERFIL

1,5x30	RECT	[1,5x29,6x0,90 cm]	P20 /peça_piece
--------	------	----------------------	-----------------

Perfil: Peças produzidas sob encomenda
 Perfil: Pieces produced on order.
 Perfil: Pièces produites sur commande.
 Perfil: Piezas producidas por encargo.

COORDENADOS · MATCHING · COORDONNÉS · COORDINADOS



BRANCO MATE ****

30x30	NAT	[...x0,81 cm]	P65
	RECT	[29,6x29,6x0,81 cm]	P78



Colors

Colors

Marfim Brilho
Kitsch
Flint Gris

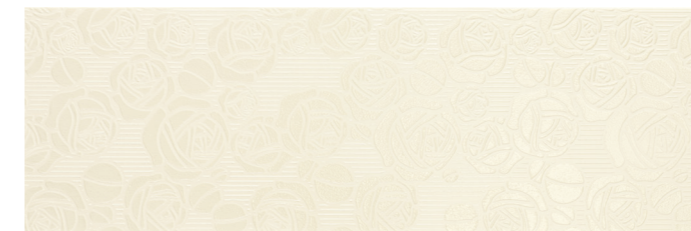

BOUQUET MARFIM
30x90 RECT [29,6x88,8x1,23 cm] P39 /peça_piece

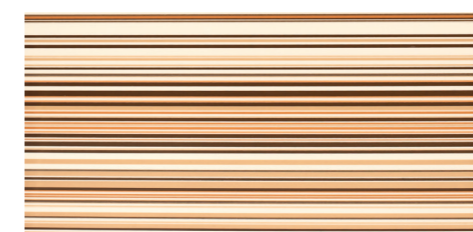

INFINITY CRAFT
30x60 RECT [29,6x59,2x0,90 cm] P15 /peça_piece



INFINITY CHERRY
30x60 RECT [29,6x59,2x0,90 cm] P15 /peça_piece



INTERLOCK
30x45 NAT [...x0,90 cm] P10 /peça_piece

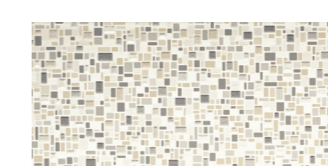

CHESS AREIA
20x40 NAT P08 /peça_piece



POPPY
30x45 NAT [...x0,90 cm] P10 /peça_piece

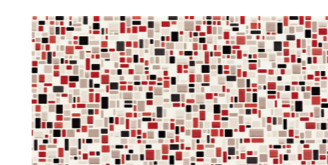

CHESS VERMELHO
20x40 NAT P08 /peça_piece

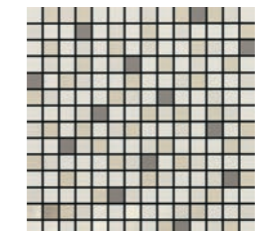

BIT MIX IRON (a)
30x30 P42 /peça_piece



KITSCH (a) (b)
30x30 P28 /peça_piece

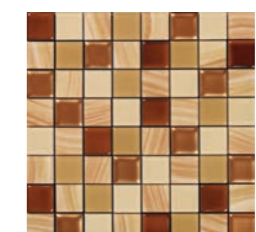

XADREZ BEGE (a)
28x28 P86 /peça_piece

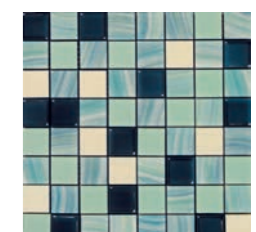

XADREZ AQUA (a)
28x28 P86 /peça_piece

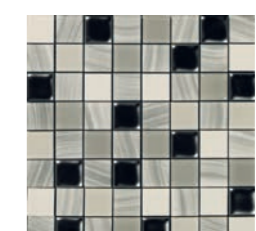

XADREZ CINZA (a)
28x28 P86 /peça_piece

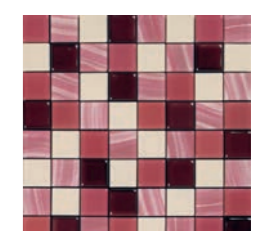

XADREZ CARMIM (a)
28x28 P86 /peça_piece

BARRA GLAM OURO
1x60 RECT [1x59,2x0,9 cm] P25

BARRA STILETTO OURO (c)
0,5x60 RECT [0,5x59,2x0,9 cm] P25

BARRA STILETTO VERMELHO (c)
0,5x60 RECT [0,5x59,2x0,9 cm] P25

BARRA GLAMMY RÚBI
0,5x60 RECT [0,5x59,2x0,9 cm] P25

BARRA STILETTO PRATA (c)
0,5x60 RECT [0,5x59,2x0,9 cm] P25

BARRA GLAM PRATA
1x60 RECT [1x59,2x0,9 cm] P25

BARRA GLAMMY ONIX
0,5x60 RECT [0,5x59,2x0,9 cm] P25

Jogos de cores que animam e delimitam os diferentes ambientes.
Play of colours that brighten and demarcate different spaces.
Jeux de couleurs qui animent et délimitent les différentes ambiances.
Juegos de colores que animan y delimitan diferentes ambientes.

illusion



Illusion Turquesa
Illusion Mix Turquesa
Cromática Jet



Illusion Mix Vermelho
Illusion Mix Preto
New Look
Cromática Jet

New Look
Illusion Mix Branco
Illusion Mix Preto
Illusion Mix Vermelho

10 cores
colors
couleurs
colores

01 formato
format
format
formato

01 acabamento
finish
finition
acabado



illusion
illusion Mix
Branco

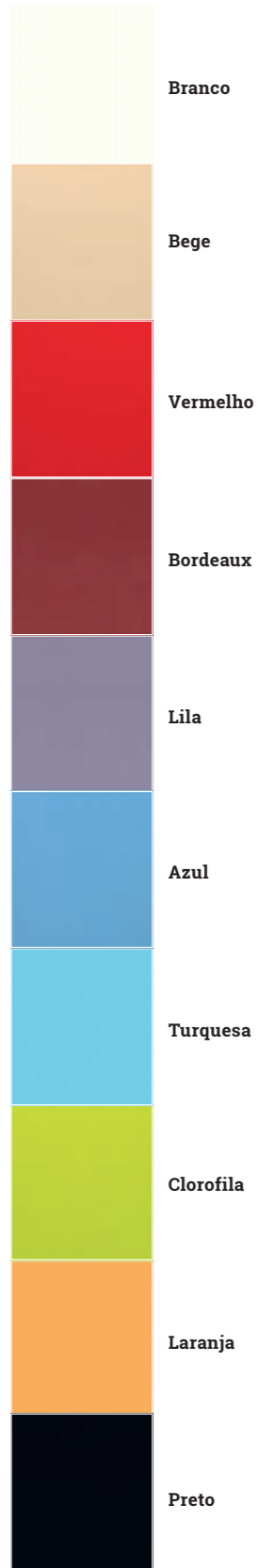

30x45
(12"x18")

Peças / Pieces		Caixa / Box			Europaleta / Europallet			
30x45 cm	Nat.	Espessura (mm) Thickness (mm)	Nº Peças No Pieces	M² Aprox. No of Sq. M. Approx.	Peso (Kg) Weight Kg	Nº Caixas No Boxes	M² Aprox. No of Sq. M. Approx.	Peso (Kg) Weight (Kg)
		± 9,0 ± 5 %	11	1,5	23,9	48	72	1 166



Illusion Mix Preto



BRANCO ORIENTE			
30x90	RECT	[29,6x88,8x1,23 cm]	P88
30x60	NAT	[...x0,90 cm]	P64
30x60	RECT	[29,6x59,2x0,90 cm]	P75
30x45	NAT	[...x0,90 cm]	P62
20x40	NAT	[...x0,84 cm]	P60



illusion
illusion Mix
Branco

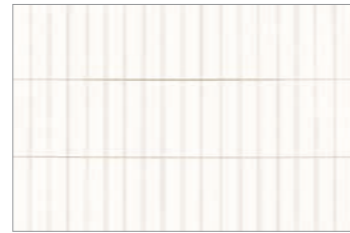

ILLUSION MIX BRANCO (*)			
30x45	NAT	[...x0,90 cm]	P69

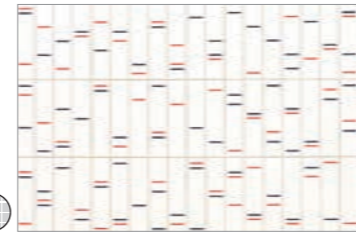

NEW LOOK (*)			
30x45	NAT	[...x0,90 cm]	P77



ILLUSION AZUL			
30x45	NAT	[...x0,90 cm]	P66

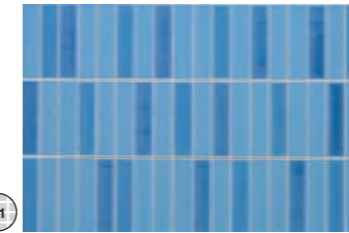

ILLUSION MIX AZUL (*)			
30x45	NAT	[...x0,90 cm]	P72



ILLUSION TURQUESA			
30x45	NAT	[...x0,90 cm]	P66

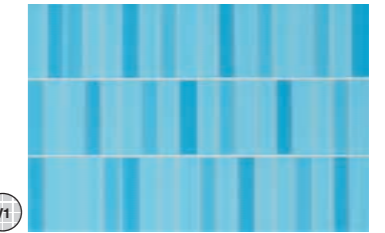

ILLUSION MIX TURQUESA (*)			
30x45	NAT	[...x0,90 cm]	P72



ILLUSION VERMELHO			
30x45	NAT	[...x0,90 cm]	P84

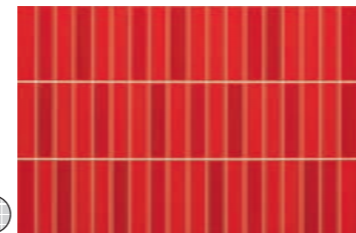

ILLUSION MIX VERMELHO (*)			
30x45	NAT	[...x0,90 cm]	P84



ILLUSION CLOROFILA			
30x45	NAT	[...x0,90 cm]	P66



ILLUSION MIX CLOROFILA (*)			
30x45	NAT	[...x0,90 cm]	P72



ILLUSION LARANJA			
30x45	NAT	[...x0,90 cm]	P66

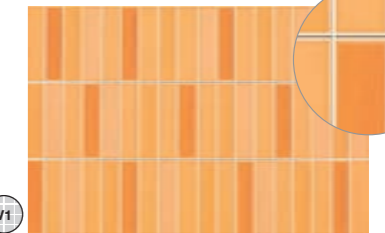

ILLUSION MIX LARANJA (*)			
30x45	NAT	[...x0,90 cm]	P72

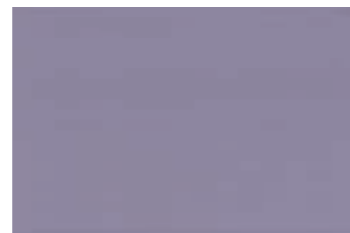

ILLUSION LILA			
30x45	NAT	[...x0,90 cm]	P66



ILLUSION MIX LILA (*)			
30x45	NAT	[...x0,90 cm]	P72



ILLUSION PRETO			
30x45	NAT	[...x0,90 cm]	P66



ILLUSION MIX PRETO (*)			
30x45	NAT	[...x0,90 cm]	P72



ILLUSION BEGE			
30x45	NAT	[...x0,90 cm]	P64



ILLUSION MIX BEGE (*)			
30x45	NAT	[...x0,90 cm]	P74



ILLUSION BORDEAUX			
30x45	NAT	[...x0,90 cm]	P84

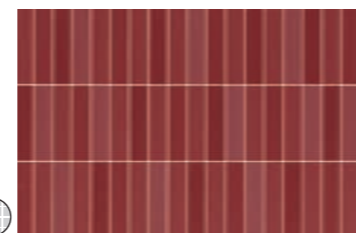

ILLUSION MIX BORDEAUX (*)			
30x45	NAT	[...x0,90 cm]	P84

(*) Devido às características deste produto, recomenda-se a betumação dos pré-cortes das peças. Dado o efeito deste produto, as peças devem ser aplicadas sempre no mesmo sentido.

(*) Due to the characteristics of the product, grouting of the pre-cut tiles is advisable. Given the effect of the product, tiles must always be laid out facing same direction.

(*) En raison des caractéristiques de ce produit, nous recommandons de sceller les prédécoupes des carreaux. En raison de l'effet de ce produit, les carreaux doivent toujours être posés dans le même sens.

(*) Debido a las características de este producto, se recomienda rejuntar los precortes de las piezas. Dado el efecto de este producto, las piezas deben aplicarse siempre en el mismo sentido.



Flick

MixPeak

Wave

Traffic Branco

Flash

MixForms

MixStep

Tetris Branco

Reliefs

Página
Page
Page
Página

MixForms	146
MixPeak	147
MixStep	148
Flash	150
Wave	150
Flick	150
Tetris	152
Traffic	158

Dinâmica e Movimento

Para criar ambientes com personalidade, a tendência é utilizar jogos de padrões, linhas e relevos que promovem dinâmica e movimento.

Dynamics and Movement

To create environments with personality, the trend is to play with patterns, lines and reliefs that foster dynamics and movement.

Dynamique et Mouvement

Pour créer des ambiances avec de la personnalité, la tendance est d'utiliser des jeux de motifs, des lignes et des reliefs qui apportent de la dynamique et du mouvement.

Dinámica y Movimiento

Para crear ambientes con personalidad, la tendencia es utilizar juegos de patrones, líneas y relevos que aportan dinámica y movimiento.



Uma mistura de linhas, volumes e texturas, com jogos de luz e sombras, que cria movimento e dá vida própria aos ambientes.
 A mix of lines, volumes and textures, with play of light and shadow, creating movement and bringing environments to life.
 Un mélange de lignes, de volumes et de textures, avec des jeux d'ombres et de lumières, qui crée du mouvement et donne vie aux ambiances.
 Una mezcla de líneas, volúmenes y texturas, con juegos de luz y sombras, que crea movimiento y da vida propia a los ambientes.



Mix Reliefs



MixForms White
 Nordik Taupe
 Loki Taupe



MixPeak White
 White Cool
 Baltic Grey

Mix Reliefs

01 cor
color
couleur
color

02 formatos
formats
formats
formatos

01 acabamento
finish
finition
acabado



Mix Reliefs

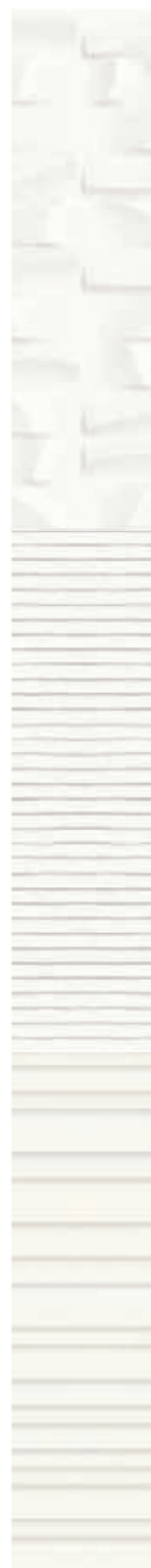

MixForms

MixPeak

MixStep



Perfil Mixstep White



Mixstep White

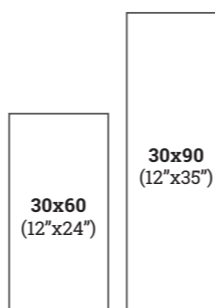

Peças - Pieces		Caixa - Box			Europaleta - Europallet			
		Espessura (mm) Thickness (mm)	Nº Peças No Pieces	MF Aprox. No of Sq. M. Approx.	Peso (Kg) Weight Kg	Nº Caixas No Boxes	MF Aprox. No of Sq. M. Approx.	Peso (Kg) Weight (Kg)
30x60 cm	Rect.	± 9,0 ± 5 %	5	0.90	14.5	72	64.8	1 065
30x90 cm	Rect.	± 12,3 ± 0,5 mm	4	1.08	22.0	40	43.2	901

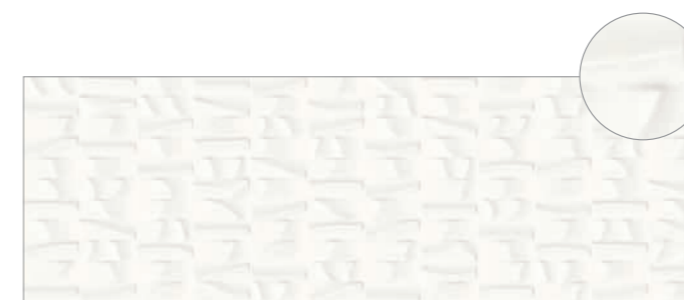

MIXFORMS WHITE (*)
30x90 RECT [29,6x88,8x1,23 cm] P88

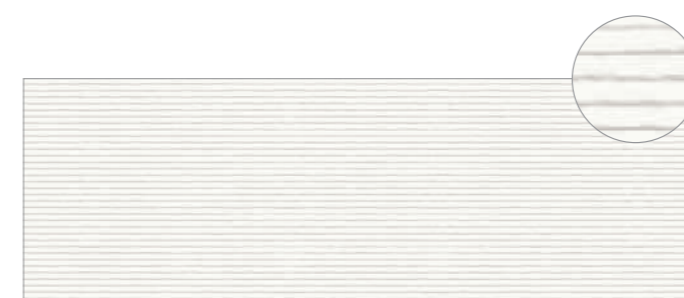

MIXPEAK WHITE (*)
30x90 RECT [29,6x88,8x1,23 cm] P88
30x60 RECT [29,6x59,2x0,90 cm] P80

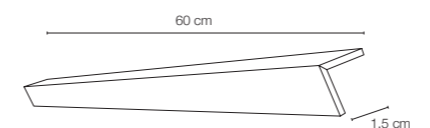

PERFIL
1,5x60 RECT [1,5x59,2x0,90 cm] P32 /peça_piece

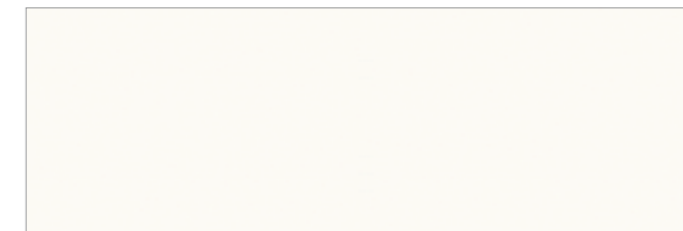

WHITE COOL
30x90 RECT [29,6x88,8x1,23 cm] P88
30x60 NAT [...x0,90 cm] P64
30x60 RECT [29,6x59,2x0,90 cm] P75



MIXSTEP WHITE (*)
30x60 RECT [29,6x59,2x0,90 cm] P80

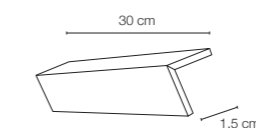

PERFIL
1,5x30 RECT [1,5x29,6x0,90 cm] P20 /peça_piece

Perfil: Peças produzidas sob encomenda.
Perfil: Pieces produced on order.
Perfil: Pièces produites sur commande.
Perfil: Piezas producidas por encargo.

(*) Dado o efeito deste produto, as peças devem ser aplicadas sempre no mesmo sentido, seguindo a orientação do dardo.

(*) Given the effect of the product, tiles must always be laid out facing same direction, following the orientation of the back.

(*) En raison de l'effet de ce produit, les carreaux doivent toujours être posés dans le même sens, en suivant l'orientation de sa face interne.

(*) Dado el efecto de este producto, las piezas deben aplicarse siempre en el mismo sentido, siguiendo la orientación del dorso.

Reliefs

01 cor
color
couleur
colore

01 formato
format
format
formato

02 acabamentos
finishes
finitions
acabados



Flash



Flick



Wave



Flash Branco Mate



Flick Branco Mate

30x90
(12"x35")

Peças / Pieces		Caixa / Box			Europaleta / Europallet			
30x90 cm	Rect.	Espessura (mm) Thickness (mm)	Nº Peças No Pieces	M² Aprox. No of Sq. M. Approx.	Peso (Kg) Weight Kg	Nº Caixas No Boxes	M² Aprox. No of Sq. M. Approx.	Peso (Kg) Weight (Kg)
30x90 cm	Rect.	12,3 ± 0,5 mm	4	1,08	22,0	40	43,2	901

Reliefs



BRANCO MATE			
30x90	RECT	[29,6x88,8x1,23 cm]	P88
30x60	NAT	[...x0,90 cm]	P64
30x60	RECT	[29,6x59,2x0,90 cm]	P75
30x45	NAT	[...x0,90 cm]	P62
20x40	NAT	[...x0,84 cm]	P60



BRANCO ORIENTE			
30x90	RECT	[29,6x88,8x1,23 cm]	P88
30x60	NAT	[...x0,90 cm]	P64
30x60	RECT	[29,6x59,2x0,90 cm]	P75
30x45	NAT	[...x0,90 cm]	P62
20x40	NAT	[...x0,84 cm]	P60

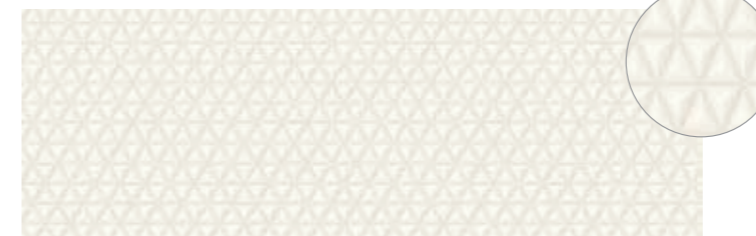

FLASH BRANCO MATE (*)			
30x90	RECT	[29,6x88,8x1,23 cm]	P88



WAVE BRANCO BRILHO (*)			
30x90	RECT	[29,6x88,8x1,23 cm]	P88



FLICK BRANCO MATE (*)			
30x90	RECT	[29,6x88,8x1,23 cm]	P88

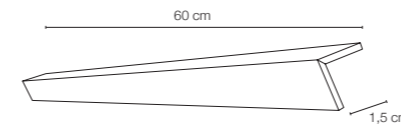

PERFIL			
1,5x60	RECT	[1,5x59,2x0,90 cm]	P32 /peça_piece

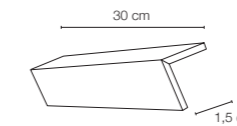

PERFIL			
1,5x30	RECT	[1,5x29,6x0,90 cm]	P20 /peça_piece

Perfil: Peças produzidas sob encomenda.
 Perfil: Pieces produced on order.
 Perfil: Pièces produites sur commande.
 Perfil: Piezas producidas por encargo.

(*) Dado o efeito deste produto, as peças devem ser aplicadas sempre no mesmo sentido, seguindo a orientação do dorso.

(*) Given the effect of the product, tiles must always be laid out facing same direction, following the orientation of the back.

(*) En raison de l'effet de ce produit, les carreaux doivent toujours être posés dans le même sens, en suivant l'orientation de sa face interne.

(*) Dado el efecto de este producto, las piezas deben aplicarse siempre en el mismo sentido, siguiendo la orientación del dorso.

Jogos de padrões, relevos e brilhos em cerâmica.
Games of patterns, reliefs and shine in ceramics.
Jeux des motifs, reliefs et éclats en céramique.
Juegos de patrones, relieves y brillos en cerámica.

Tetris



Tetris Gold
Globe Antracite



Tetris Branco
Tetris Lila
Tetris Clorofila
Tetris Gris
Pixel
Cromática Clorofila
Cromática Ice

Tetris

10 cores
colors
couleurs
colores

01 formato
format
format
formato

01 acabamento
finish
finition
acabado

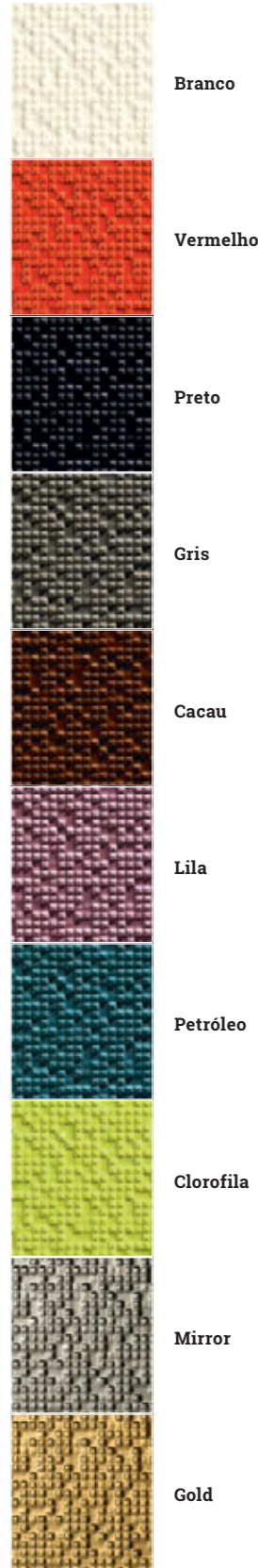

ZOOM

30x60
(12"x24")

30x60 cm	Peças - Pieces		Caixa - Box			Europaleta - Europallet			
	Rect.	Tetris	Espe- sura (mm) Thickness (mm)	Nº Peças No Pieces	M² Aprox. No of Sq. M. Approx.	Peso (Kg) Weight Kg	Nº Caixas No Boxes	M² Aprox. No of Sq. M. Approx.	Peso (Kg) Weight (Kg)
			± 9,0 ± 5 %	5	0.90	14.5	72	64.8	1 065
			± 9,0 ± 5 %	7	1.25	20.0	24	30.0	501

Tetris



Tetris Petróleo
Tetris Branco
Urban Fog
Deck Gris

Tetris

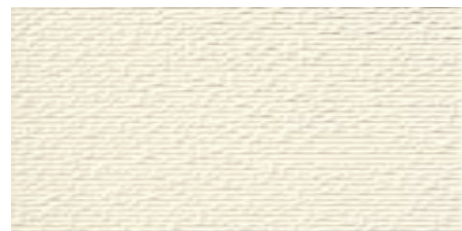

TETRIS BRANCO
30x60 RECT [29,6x59,2x0,90 cm] P80

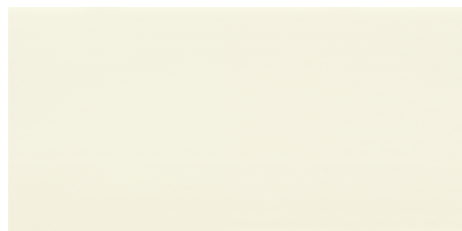

MARFIM BRILHO
30x90 RECT [29,6x88,8x1,23 cm] P88
30x60 NAT [...x0,90 cm] P64
30x60 RECT [29,6x59,2x0,90 cm] P75



TETRIS GRIS
30x60 RECT [29,6x59,2x0,90 cm] P80

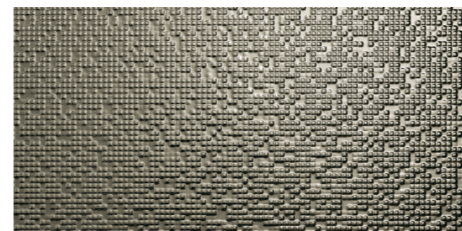

TETRIS MIRROR (*)
30x60 RECT [29,6x59,2x0,90 cm] P373



IRON BRILHO
30x60 NAT [...x0,90 cm] P66
30x60 RECT [29,6x59,2x0,90 cm] P77



BRANCO ORIENTE
30x90 RECT [29,6x88,8x1,23 cm] P88
30x60 NAT [...x0,90 cm] P64
30x60 RECT [29,6x59,2x0,90 cm] P75
30x45 NAT [...x0,90 cm] P62
20x40 NAT [...x0,84 cm] P60

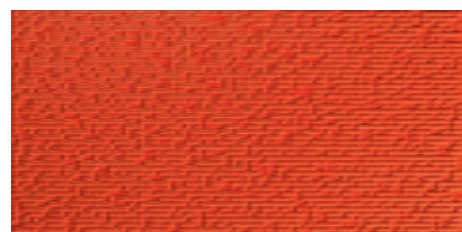

TETRIS VERMELHO
30x60 RECT [29,6x59,2x0,90 cm] P80

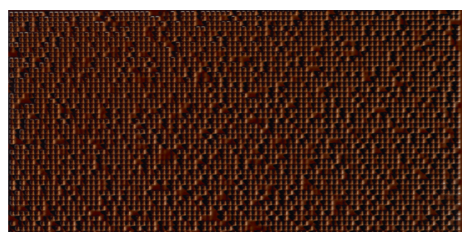

TETRIS CACAU
30x60 RECT [29,6x59,2x0,90 cm] P80



TETRIS CLOROFILA
30x60 RECT [29,6x59,2x0,90 cm] P80

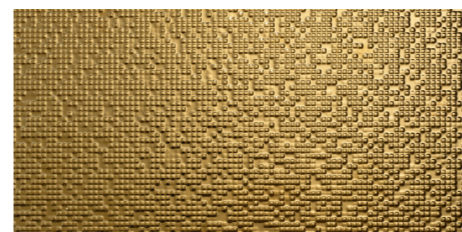

TETRIS GOLD (*)
30x60 RECT [29,6x59,2x0,90 cm] P373



PIXEL
30x60 RECT [29,6x59,2x0,90 cm] P30 / peça_pieça



TETRIS LILA
30x60 RECT [29,6x59,2x0,90 cm] P80



TETRIS PRETO
30x60 RECT [29,6x59,2x0,90 cm] P80



PRETO BRILHO
30x60 NAT [...x0,90 cm] P69
30x60 RECT [29,6x59,2x0,90 cm] P80



TETRIS PETRÓLEO
30x60 RECT [29,6x59,2x0,90 cm] P80



(*) Dado o efeito de espelho deste produto, não devem ser utilizados utensílios ou produtos de limpeza ácidos ou abrasivos, os quais poderão danificar a decoração metálica.
(* Avoid using acid or abrasive cleaning products or utensils that may damage the metal finish and product mirror effect.
(* Pour préserver l'effet brillant miroir de ce produit, nous recommandons de ne pas utiliser la surface avec des instruments ou des nettoyeurs acides ou abrasifs car ils peuvent endommager l'aspect métal.
(* Debido al efecto espejo de este producto, no se deben utilizar utensilios ni productos de limpieza ácidos o abrasivos, ya que podrían dañar la decoración metálica.

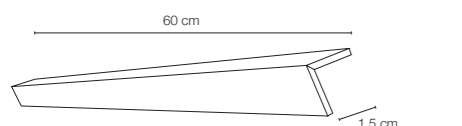

PERFIL
1,5x60 RECT [1,5x59,2x0,90 cm] P32 /peça_pieça

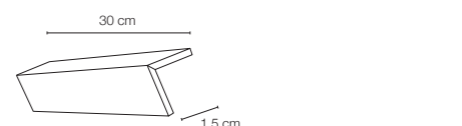

PERFIL
1,5x30 RECT [1,5x29,6x0,90 cm] P20 /peça_pieça

Perfil: Peças produzidas sob encomenda.
Perfil: Pieces produced on order.
Perfil: Pièces produites sur commande.
Perfil: Piezas producidas por encargo.

O efeito mureto dos ambientes citadinos.
The wall effect of city environments.
L'effet de muret des ambiances citadines.
El efecto muro de los ambientes urbanos.

Traffic



Traffic Mix



Traffic Preto
Traffic Branco
Exotic Castanho

03 cores
colors
couleurs
colores

01 formato
format
format
formato

01 acabamento
finish
finition
acabado

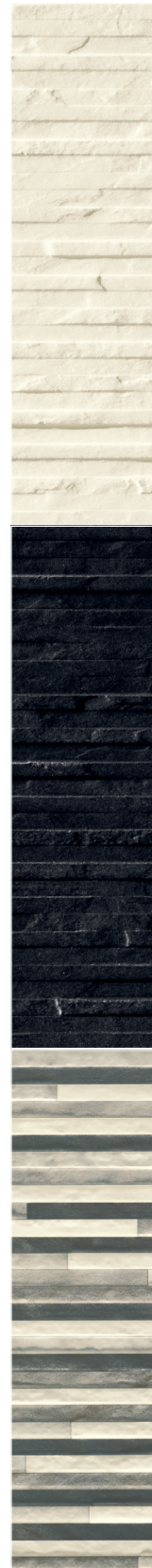

Branco

Preto

Mix



Traffic Branco

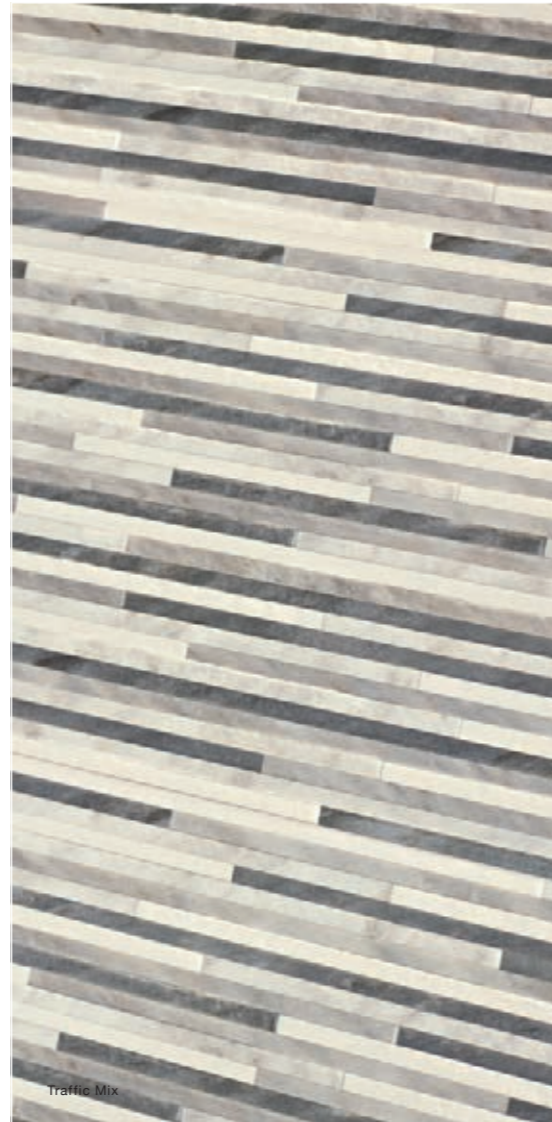

Traffic Mix

ZOOM

30x60
(12"x24")

Peças / Pieces		Caixa / Box			Europaleta / Europallet			
30x60 cm	Rect.	Espessura (mm) Thickness (mm)	Nº Peças No Pieces	M² Aprox. No of Sq. M. Approx.	Peso (Kg) Weight Kg	Nº Caixas No Boxes	M² Aprox. No of Sq. M. Approx.	Peso (Kg) Weight (Kg)
		± 9,0 ± 5 %	5	0,9	14,5	72	64,8	1 065



TRAFFIC BRANCO
30x60 RECT [29,6x59,2x0,90 cm] P80



TRAFFIC MIX
30x60 RECT [29,6x59,2x0,90 cm] P80



TRAFFIC PRETO
30x60 RECT [29,6x59,2x0,90 cm] P80

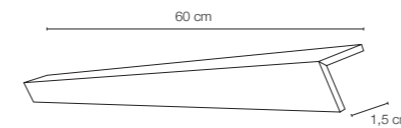

PERFIL
1,5x60 RECT [1,5x59,2x0,90 cm] P32 /peça /piece

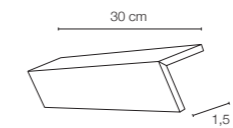

PERFIL
1,5x30 RECT [1,5x29,6x0,90 cm] P20 /peça /piece

Perfil: Peças produzidas sob encomenda.
Perfil: Pieces produced on order.
Perfil: Pièces produites sur commande.
Perfil: Piezas producidas por encargo.

COORDENADOS · MATCHING · COORDONNÉS · COORDINADOS

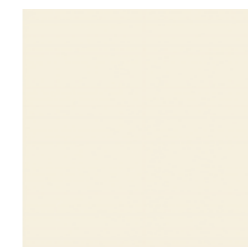

CROMÁTICA ICE
30x30 SOFT [29,6x29,6x0,90 cm] P163



CROMÁTICA JET
30x30 SOFT [29,6x29,6x0,85 cm] P123

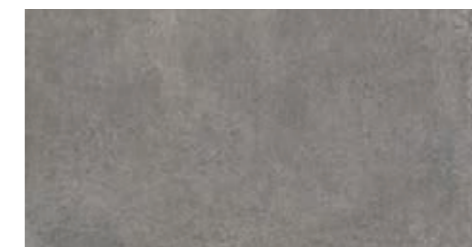

URBAN GRIS
30x60 RECT [29,6x59,2x0,85 cm] P79



Concrete

Página
Page
Page
Página

Cityzen	164
Elements	172
Globe	182
Silken	188
Planet	196
Nimbus	202
Urban	210

Inspiração Industrial

O cimento permite criar espaços com uma inspiração industrial que são, em simultâneo, sofisticados, modernos e contemporâneos. Combine-o com o efeito de outros materiais como a madeira.

Industrial Inspiration

Cement allows you to create space with industrial inspiration, which is simultaneously sophisticated, modern and contemporary. Combine it with the effect of other materials such as wood.

Inspiration Industrielle

Le ciment permet de créer des espaces d'inspiration industrielle à la fois sophistiqués, modernes et contemporains. Combinez-le avec l'effet d'autres matériaux comme le bois.

Inspiración Industrial

El cemento permite crear espacios de inspiración industrial que son, al mismo tiempo, sofisticados, modernos y contemporáneos. Combínelo con el efecto de otros materiales como la madera.

NEW

A subtileza orgânica do cimento, enriquecida com tonalidades e texturas, promove a serenidade em ambientes citadinos.
The organic subtletness of cement, enriched with shades and textures, caters for serenity in city environments.
La subtilité organique du ciment, enrichie des tonalités et des textures, promeuve la sérénité dans les ambiances citadines.
La sutileza orgánica del cemento enriquecida con tonos y texturas que fomentan la serenidad en ambientes urbanos.

Cityzen



Cityzen Carbon
Cityzen Offwhite
MixPeak White



Cityzen Carbon
Cityzen Fog

05 cores
colors
couleurs
colores

05 formatos
formats
formats
formatos

03 acabamentos
finishes
finitions
acabados

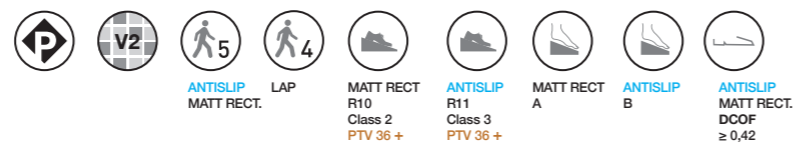

Offwhite

Bone

Fog

Gris

Carbon



GRAPHIC VARIATION

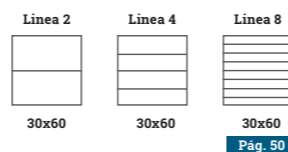
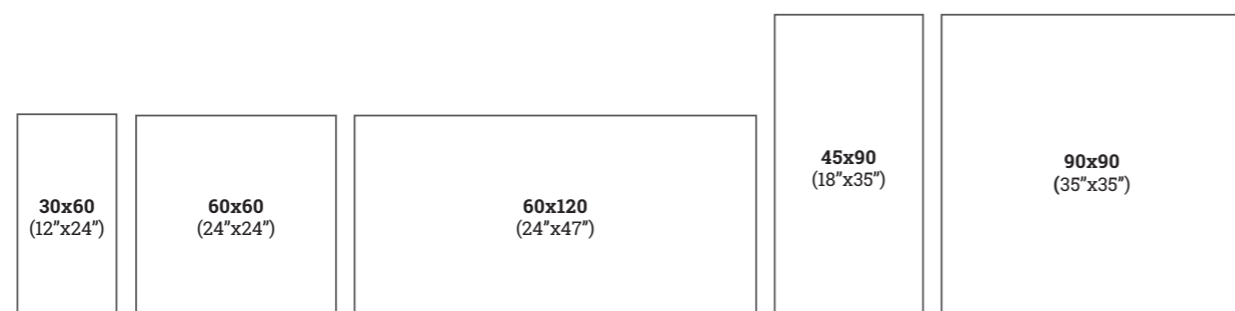

Peças - Pieces		Espessura (mm) Thickness (mm)	Caixa - Box		Peso (Kg) Weight Kg	Europalets - Europallet		Peso (Kg) Weight (Kg)
Formato	Acabamento		Nº Peças No Pieces	M² Aprox. No of Sq. M. Approx.		Nº Caixas No Boxes	M² Aprox. No of Sq. M. Approx.	
30x60 cm	Matt Rect./Lap	± 8,5 ±5%	5	0.90	18.0	60	54.00	1 101
60x60 cm	Antislip Rect. / Matt Rect./Lap	± 8,5 ±5%	4	1.44	28.7	36	51.84	1 053
60x120 cm	Matt Rect./Lap	± 9,8 ±5%	2	1.44	33.0	30	43.20	1 011
45x90 cm	Matt Rect./Lap	± 10,5 ±0,5 mm	4	1.62	39.0	27	43.74	1 074
90x90 cm	Matt Rect./Lap	± 10,5 ±0,5 mm	2	1.62	39.0	24	38.88	991



Cityzen Bone
Cityzen Gris

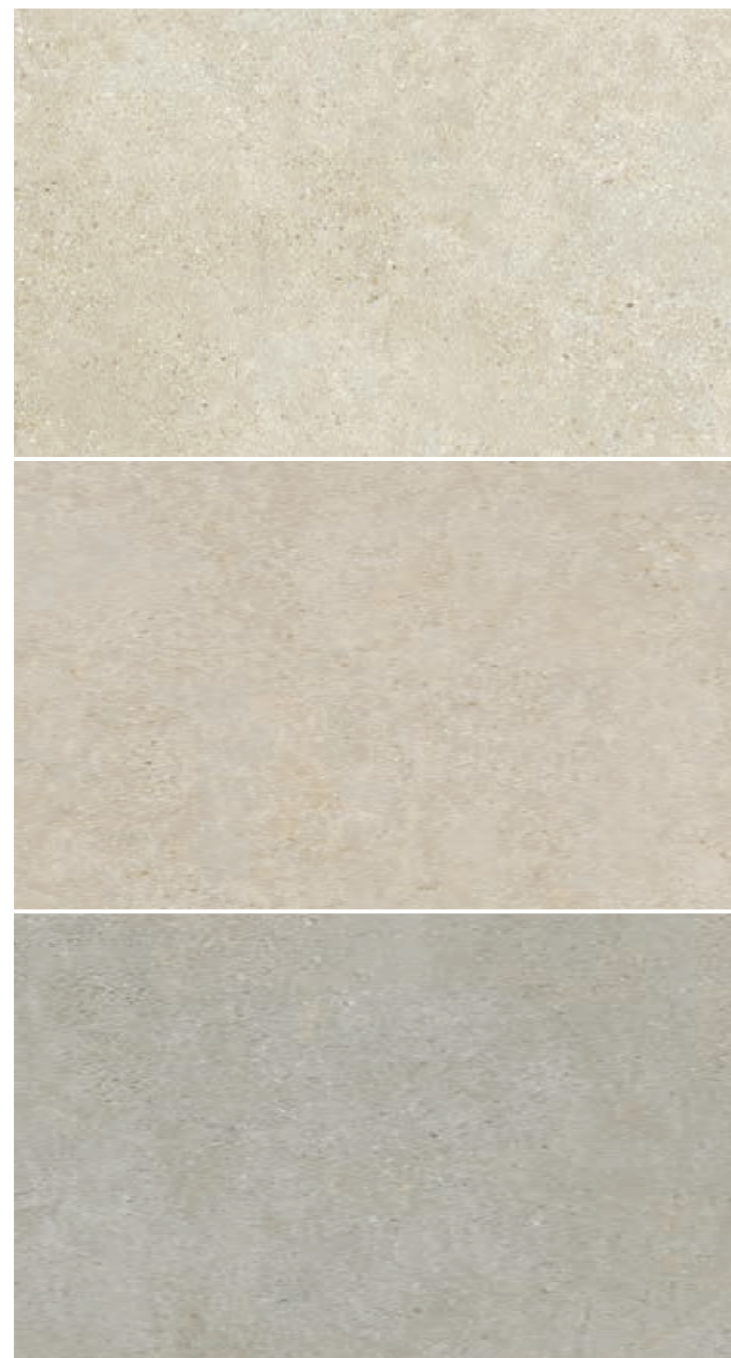

CITYZEN OFFWHITE

90x90	MATT RECT	[89,0x89,0x1,05 cm]	P109	V2	5	class 2	A	R10	36*	≥0,42
	LAP	[89,0x89,0x1,05 cm]	P117	V2	4	—	—	—	—	—
60x60	MATT RECT	[59,2x59,2x0,85 cm]	P87	V2	5	class 2	A	R10	36*	≥0,42
	LAP	[59,2x59,2x0,85 cm]	P95	V2	4	—	—	—	—	—
60x60	ANTISLIP RECT	[59,2x59,2x0,85 cm]	P87	V2	5	class 3	B	R11	36*	≥0,42
	LAP	[59,2x118,4x0,98 cm]	P109	V2	5	class 2	A	R10	36*	≥0,42
60x120	MATT RECT	[59,2x118,4x0,98 cm]	P117	V2	4	—	—	—	—	—
	LAP	[59,2x118,4x0,98 cm]	P117	V2	4	—	—	—	—	—
45x90	MATT RECT	[44,5x89,0x1,05 cm]	P94	V2	5	class 2	A	R10	36*	≥0,42
	LAP	[44,5x89,0x1,05 cm]	P102	V2	4	—	—	—	—	—
30x60	MATT RECT	[29,6x59,2x0,85 cm]	P87	V2	5	class 2	A	R10	36*	≥0,42
	LAP	[29,6x59,2x0,85 cm]	P95	V2	4	—	—	—	—	—

CITYZEN BONE

90x90	MATT RECT	[89,0x89,0x1,05 cm]	P109	V2	5	class 2	A	R10	36*	≥0,42
	LAP	[89,0x89,0x1,05 cm]	P117	V2	4	—	—	—	—	—
60x60	MATT RECT	[59,2x59,2x0,85 cm]	P87	V2	5	class 2	A	R10	36*	≥0,42
	LAP	[59,2x59,2x0,85 cm]	P95	V2	4	—	—	—	—	—
60x60	ANTISLIP RECT	[59,2x59,2x0,85 cm]	P87	V2	5	class 3	B	R11	36*	≥0,42
	LAP	[59,2x118,4x0,98 cm]	P109	V2	5	class 2	A	R10	36*	≥0,42
60x120	MATT RECT	[59,2x118,4x0,98 cm]	P117	V2	4	—	—	—	—	—
	LAP	[59,2x118,4x0,98 cm]	P117	V2	4	—	—	—	—	—
45x90	MATT RECT	[44,5x89,0x1,05 cm]	P94	V2	5	class 2	A	R10	36*	≥0,42
	LAP	[44,5x89,0x1,05 cm]	P102	V2	4	—	—	—	—	—
30x60	MATT RECT	[29,6x59,2x0,85 cm]	P87	V2	5	class 2	A	R10	36*	≥0,42
	LAP	[29,6x59,2x0,85 cm]	P95	V2	4	—	—	—	—	—

CITYZEN FOG

90x90	MATT RECT	[89,0x89,0x1,05 cm]	P109	V2	5	class 2	A	R10	36*	≥0,42
	LAP	[89,0x89,0x1,05 cm]	P117	V2	4	—	—	—	—	—
60x60	MATT RECT	[59,2x59,2x0,85 cm]	P87	V2	5	class 2	A	R10	36*	≥0,42
	LAP	[59,2x59,2x0,85 cm]	P95	V2	4	—	—	—	—	—
60x60	ANTISLIP RECT	[59,2x59,2x0,85 cm]	P87	V2	5	class 3	B	R11	36*	≥0,42
	LAP	[59,2x118,4x0,98 cm]	P109	V2	5	class 2	A	R10	36*	≥0,42
60x120	MATT RECT	[59,2x118,4x0,98 cm]	P117	V2	4	—	—	—	—	—
	LAP	[59,2x118,4x0,98 cm]	P117	V2	4	—	—	—	—	—
45x90	MATT RECT	[44,5x89,0x1,05 cm]	P94	V2	5	class 2	A	R10	36*	≥0,42
	LAP	[44,5x89,0x1,05 cm]	P102	V2	4	—	—	—	—	—
30x60	MATT RECT	[29,6x59,2x0,85 cm]	P87	V2	5	class 2	A	R10	36*	≥0,42
	LAP	[29,6x59,2x0,85 cm]	P95	V2	4	—	—	—	—	—



CITYZEN GRIS

90x90	MATT RECT	[89,0x89,0x1,05 cm]	P109	V2	5	class 2	A	R10	36*	≥0,42
	LAP	[89,0x89,0x1,05 cm]	P117	V2	4	—	—	—	—	—
60x60	MATT RECT	[59,2x59,2x0,85 cm]	P87	V2	5	class 2	A	R10	36*	≥0,42
	LAP	[59,2x59,2x0,85 cm]	P95	V2	4	—	—	—	—	—
60x60	ANTISLIP RECT	[59,2x59,2x0,85 cm]	P87	V2	5	class 3	B	R11	36*	≥0,42
	LAP	[59,2x118,4x0,98 cm]	P109	V2	5	class 2	A	R10	36*	≥0,42
60x120	MATT RECT	[59,2x118,4x0,98 cm]	P117	V2	4	—	—	—	—	—
	LAP	[59,2x118,4x0,98 cm]	P117	V2	4	—	—	—	—	—
45x90	MATT RECT	[44,5x89,0x1,05 cm]	P94	V2	5	class 2	A	R10	36*	≥0,42
	LAP	[44,5x89,0x1,05 cm]	P102	V2	4	—	—	—	—	—
30x60	MATT RECT	[29,6x59,2x0,85 cm]	P87	V2	5	class 2	A	R10	36*	≥0,42
	LAP	[29,6x59,2x0,85 cm]	P95	V2	4	—	—	—	—	—

CITYZEN CARBON

90x90	MATT RECT	[89,0x89,0x1,05 cm]	P109	V2	5	class 2	A	R10	36*	≥0,42
	LAP	[89,0x89,0x1,05 cm]	P117	V2	4	—	—	—	—	—
60x60	MATT RECT	[59,2x59,2x0,85 cm]	P87	V2	5	class 2	A	R10	36*	≥0,42
	LAP	[59,2x59,2x0,85 cm]	P95	V2	4	—	—	—	—	—
60x60	ANTISLIP RECT	[59,2x59,2x0,85 cm]	P87	V2	5	class 3	B	R11	36*	≥0,42
	LAP	[59,2x118,4x0,98 cm]	P109	V2	5	class 2	A	R10	36*	≥0,42
60x120	MATT RECT	[59,2x118,4x0,98 cm]	P117	V2	4	—	—	—	—	—
	LAP	[59,2x118,4x0,98 cm]	P117	V2	4	—	—	—	—	—
45x90	MATT RECT	[44,5x89,0x1,05 cm]	P94	V2	5	class 2	A	R10	36*	≥0,42
	LAP	[44,5x89,0x1,05 cm]	P102	V2	4	—	—	—	—	—
30x60	MATT RECT	[29,6x59,2x0,85 cm]	P87	V2	5	class 2	A	R10	36*	≥0,42
	LAP	[29,6x59,2x0,85 cm]	P95	V2	4	—	—	—	—	—



STRATUS 36
CITYZEN OFFWHITE (a) (f)
30x30 P19 / peça_peice



STRATUS 36
CITYZEN BONE (a) (f)
30x30 P19 / peça_peice

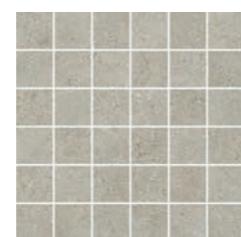

STRATUS 36
CITYZEN FOG (a) (f)
30x30 P19 / peça_peice



STRATUS 36
CITYZEN GRIS (a) (f)
30x30 P19 / peça_peice

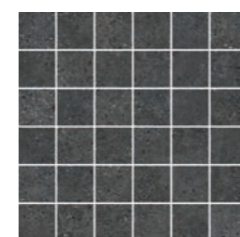

STRATUS 36
CITYZEN CARBON (a) (f)
30x30 P19 / peça_peice

ANTISLIP: Produtos que minimizam o risco de deslizamento.
ANTISLIP: Products that minimize the risk of slipping.
ANTISLIP: Produits qui réduisent le risque de glissement.
ANTISLIP: Productos que minimizan el riesgo de deslizamiento.



Cityzen Bone Lap



Cityzen Offwhite Matt Rect

ZOOM

DG	PEÇA _ PIECE		RB	PEÇA _ PIECE		DG CF	PEÇA _ PIECE		DG CF CANTO	PEÇA _ PIECE	
	Matt Rect	Lap		Matt Rect	Lap		Matt Rect	Lap		Matt Rect	Lap
30x60 cm	P18	P18	9,5x30 cm	P08	P08	30x60 cm	P157	P157	30x60 cm	P207	P207
60x60 cm	P36	P36	8x45 cm	P16	P16						
45x90 cm	P97	P97	8x60 cm	P12	P12						
30x120 cm	P97	P97	8x90 cm	P28	P28						
60x120 cm	P167	P167	8x120 cm	P28	P28						

DG CF / DG CF Canto: Peças produzidas sob encomenda.
 DG CF / DG CF Canto: Pieces produced on order.
 DG CF / DG CF Canto: Pièces produites sur commande
 DG CF / DG CF Canto: Piezas producidas por encargo

DG CF Canto: Disponível em canto esquerdo e direito.
 DG CF Canto: Available in left and right corner.
 DG CF Canto: Disponible en angle gauche et droit.
 DG CF Canto: Canto izquierdo y derecho disponibles.



Cityzen Fog



DG CF / CF CANTO Cityzen Gris



A nobreza das matérias-primas para espaços urbanos e minimalistas.
 The nobleness of the raw materials for urban and minimalist spaces.
 La noblesse des matières premières pour les espaces urbains et minimalistes.
 La nobleza de las materias primas para espacios urbanos y minimalistas.



Elements



Elements Carbon
 Elements Fog



Elements Fog
 Elements Mixmood Fog

NEW

Elements

04 cores
couleurs
colores

04 formatos
formats
formats

02 acabamentos
finishes
finitions
acabados

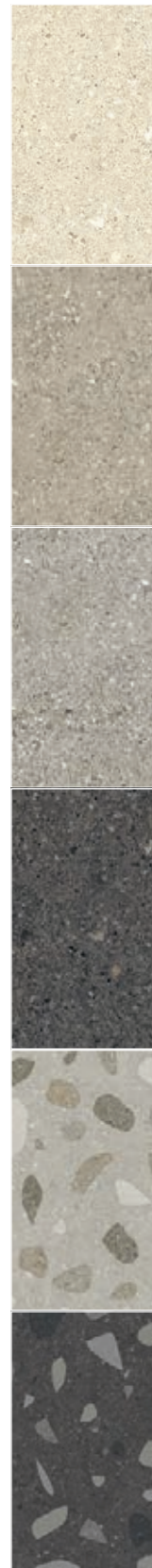
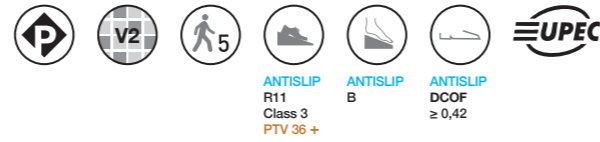

Mist

Smoke

Fog

Carbon

Terrazzo Fog

Terrazzo Carbon



GRAPHIC VARIATION

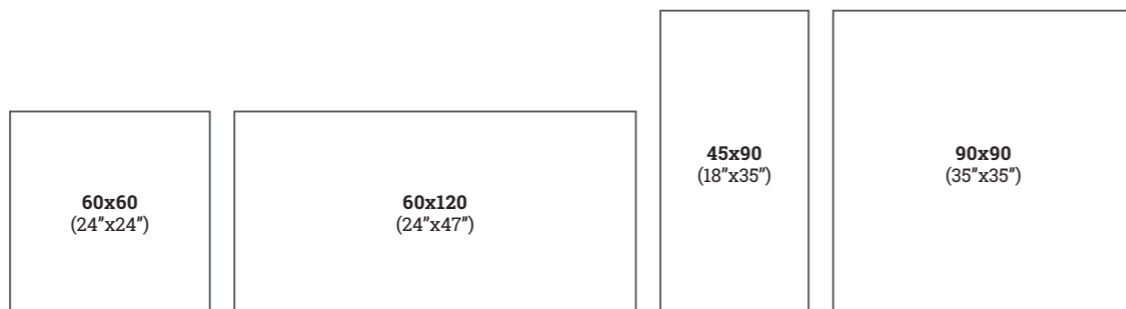

Peças / Pieces		Espessura (mm) Thickness (mm)	Caixa / Box		Europalet / Europallet			
Nº Peças No Pieces	M² Aprox. No of Sq. M. Approx.		Peso (Kg) Weight Kg	Nº Caixas No Boxes	M² Aprox. No of Sq. M. Approx.	Peso (Kg) Weight (Kg)		
60x60 cm	Antislip Rect / Soft	± 8,5 ±5%	4	1.44	28.7	36	51.84	1 053
60x120 cm	Antislip Rect / Soft	± 9,8 ±5%	2	1.44	33.0	30	43.20	1 011
45x90 cm	Antislip Rect / Soft	± 10,5 ±0,5 mm	4	1.62	39.0	27	43.74	1 074
90x90 cm	Antislip Rect / Soft	± 10,5 ±0,5 mm	2	1.62	39.0	24	38.88	991

Elements



Elements Terrazzo Carbon

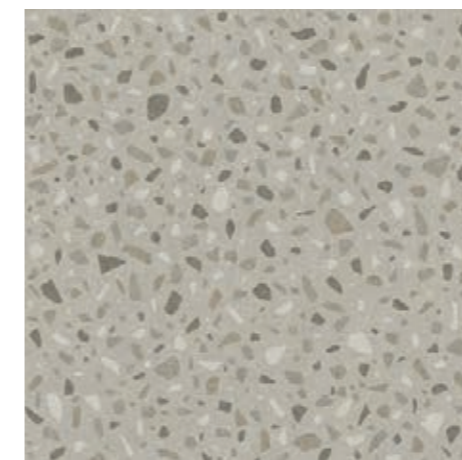

ELEMENTS TERRAZZO FOG

90x90	SOFT	[89,0x89,0x1,05 cm]	P113	V2	5	—	—	—	—	—
	ANTI SLIP RECT	[89,0x89,0x1,05 cm]	P113	V2	5	class 3	B	R11	36+	≥0,42
60x60	SOFT	[59,2x59,2x0,85 cm]	P91	V2	5	—	—	—	—	—
	ANTI SLIP RECT	[59,2x59,2x0,85 cm]	P91	V2	5	class 3	B	R11	36+	≥0,42



ELEMENTS TERRAZZO CARBON

90x90	SOFT	[89,0x89,0x1,05 cm]	P113	V2	5	—	—	—	—	—
	ANTI SLIP RECT	[89,0x89,0x1,05 cm]	P113	V2	5	class 3	B	R11	36+	≥0,42
60x60	SOFT	[59,2x59,2x0,85 cm]	P91	V2	5	—	—	—	—	—
	ANTI SLIP RECT	[59,2x59,2x0,85 cm]	P91	V2	5	class 3	B	R11	36+	≥0,42

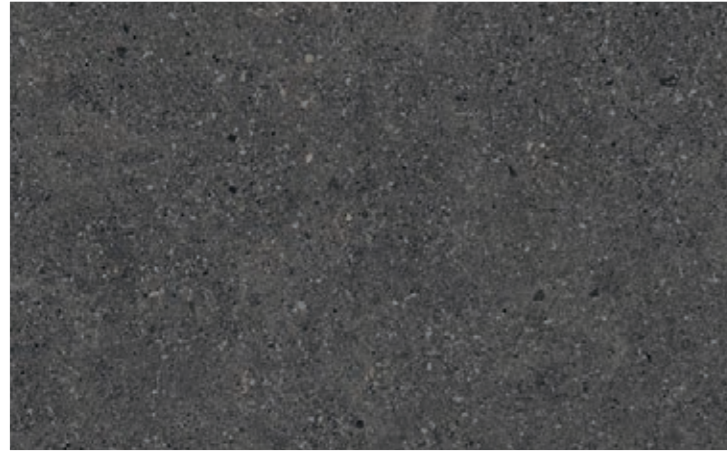

ELEMENTS MIST

Size	Finish	Dimensions	Product Code	Class	Slip	Friction	Impact	Acoustic	U-value
90x90	SOFT	[89,0x89,0x1,05 cm]	P117	V2	5	—	—	—	U4P3E3C2
	ANTISLIP RECT	[89,0x89,0x1,05 cm]	P117	V2	5 class 3	B	R11	36+ ≥0,42	U4P3E3C2
60x60	SOFT	[59,2x59,2x0,85 cm]	P97	V2	5	—	—	—	U4P4E3C2
	ANTISLIP RECT	[59,2x59,2x0,85 cm]	P97	V2	5 class 3	B	R11	36+ ≥0,42	U4P4E3C2
60x120	SOFT	[59,2x118,4x0,98 cm]	P117	V2	5	—	—	—	U4P3E3C2
	ANTISLIP RECT	[59,2x118,4x0,98 cm]	P117	V2	5 class 3	B	R11	36+ ≥0,42	U4P3E3C2
45x90	SOFT	[44,5x89,0x1,05 cm]	P104	V2	5	—	—	—	U4P3E3C2
	ANTISLIP RECT	[44,5x89,0x1,05 cm]	P104	V2	5 class 3	B	R11	36+ ≥0,42	U4P3E3C2

ELEMENTS SMOKE

Size	Finish	Dimensions	Product Code	Class	Slip	Friction	Impact	Acoustic	U-value
90x90	SOFT	[89,0x89,0x1,05 cm]	P109	V2	5	—	—	—	U4P3E3C2
	ANTISLIP RECT	[89,0x89,0x1,05 cm]	P109	V2	5 class 3	B	R11	36+ ≥0,42	U4P3E3C2
60x60	SOFT	[59,2x59,2x0,85 cm]	P87	V2	5	—	—	—	U4P4E3C2
	ANTISLIP RECT	[59,2x59,2x0,85 cm]	P87	V2	5 class 3	B	R11	36+ ≥0,42	U4P4E3C2
60x120	SOFT	[59,2x118,4x0,98 cm]	P109	V2	5	—	—	—	U4P3E3C2
	ANTISLIP RECT	[59,2x118,4x0,98 cm]	P109	V2	5 class 3	B	R11	36+ ≥0,42	U4P3E3C2
45x90	SOFT	[44,5x89,0x1,05 cm]	P94	V2	5	—	—	—	U4P3E3C2
	ANTISLIP RECT	[44,5x89,0x1,05 cm]	P94	V2	5 class 3	B	R11	36+ ≥0,42	U4P3E3C2

ELEMENTS FOG

Size	Finish	Dimensions	Product Code	Class	Slip	Friction	Impact	Acoustic	U-value
90x90	SOFT	[89,0x89,0x1,05 cm]	P109	V2	5	—	—	—	U4P3E3C2
	ANTISLIP RECT	[89,0x89,0x1,05 cm]	P109	V2	5 class 3	B	R11	36+ ≥0,42	U4P3E3C2
60x60	SOFT	[59,2x59,2x0,85 cm]	P87	V2	5	—	—	—	U4P4E3C2
	ANTISLIP RECT	[59,2x59,2x0,85 cm]	P87	V2	5 class 3	B	R11	36+ ≥0,42	U4P4E3C2
60x120	SOFT	[59,2x118,4x0,98 cm]	P109	V2	5	—	—	—	U4P3E3C2
	ANTISLIP RECT	[59,2x118,4x0,98 cm]	P109	V2	5 class 3	B	R11	36+ ≥0,42	U4P3E3C2
45x90	SOFT	[44,5x89,0x1,05 cm]	P94	V2	5	—	—	—	U4P3E3C2
	ANTISLIP RECT	[44,5x89,0x1,05 cm]	P94	V2	5 class 3	B	R11	36+ ≥0,42	U4P3E3C2

ELEMENTS CARBON

Size	Finish	Dimensions	Product Code	Class	Slip	Friction	Impact	Acoustic	U-value
90x90	SOFT	[89,0x89,0x1,05 cm]	P109	V2	5	—	—	—	U4P3E3C2
	ANTISLIP RECT	[89,0x89,0x1,05 cm]	P109	V2	5 class 3	B	R11	36+ ≥0,42	U4P3E3C2
60x60	SOFT	[59,2x59,2x0,85 cm]	P87	V2	5	—	—	—	U4P4E3C2
	ANTISLIP RECT	[59,2x59,2x0,85 cm]	P87	V2	5 class 3	B	R11	36+ ≥0,42	U4P4E3C2
60x120	SOFT	[59,2x118,4x0,98 cm]	P109	V2	5	—	—	—	U4P3E3C2
	ANTISLIP RECT	[59,2x118,4x0,98 cm]	P109	V2	5 class 3	B	R11	36+ ≥0,42	U4P3E3C2
45x90	SOFT	[44,5x89,0x1,05 cm]	P94	V2	5	—	—	—	U4P3E3C2
	ANTISLIP RECT	[44,5x89,0x1,05 cm]	P94	V2	5 class 3	B	R11	36+ ≥0,42	U4P3E3C2

Antislip: Produtos que minimizam o risco de deslizamento.
 Antislip: Products that minimize the risk of slipping.
 Antislip: Produits qui réduisent le risque de glissement.
 Antislip: Productos que minimizan el riesgo de deslizamiento.



ZOOM

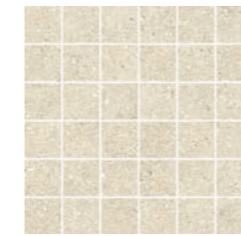

STRATUS 36 ELEMENTS MIST (a) (f)
30x30 SOFT P19 / peça_peice

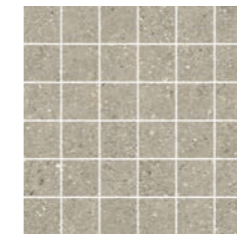

STRATUS 36 ELEMENTS SMOKE (a) (f)
30x30 SOFT P19 / peça_peice

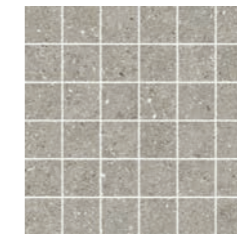

STRATUS 36 ELEMENTS FOG (a) (f)
30x30 SOFT P19 / peça_peice

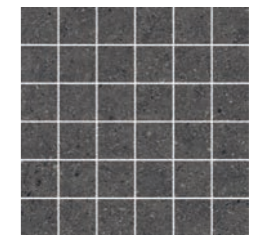

STRATUS 36 ELEMENTS CARBON (a) (f)
30x30 SOFT P19 / peça_peice

DG	Antislip Rect	Soft	RB	Antislip Rect	Soft	DG CF	Antislip Rect	Soft	DG CF CANTO	Antislip Rect	Soft
30x60 cm	P18	P18	8x45 cm	P16	P16	30x60 cm	P157	P157	30x60 cm	P207	P207
60x60 cm	P36	P36	8x60 cm	P12	P12						
45x90 cm	P97	P97	8x90 cm	P28	P28						
30x120 cm	P97	P97	8x120 cm	P28	P28						
60x120 cm	P167	P167									

DG CF / DG CF Canto: Peças produzidas sob encomenda.
 DG CF / DG CF Canto: Pieces produced on order.
 DG CF / DG CF Canto: Pièces produites sur commande
 DG CF / DG CF Canto: Piezas producidas por encargo

DG CF Canto: Disponível em canto esquerdo e direito.
 DG CF Canto: Available in left and right corner.
 DG CF Canto: Disponible en angle gauche et droit.
 DG CF Canto: Canto izquierdo y derecho disponibles.

NEW

Elements

- 04** cores
colors
couleurs
colores
- 02** formatos
formats
formats
formatos
- 01** acabamento
finish
finition
acabado

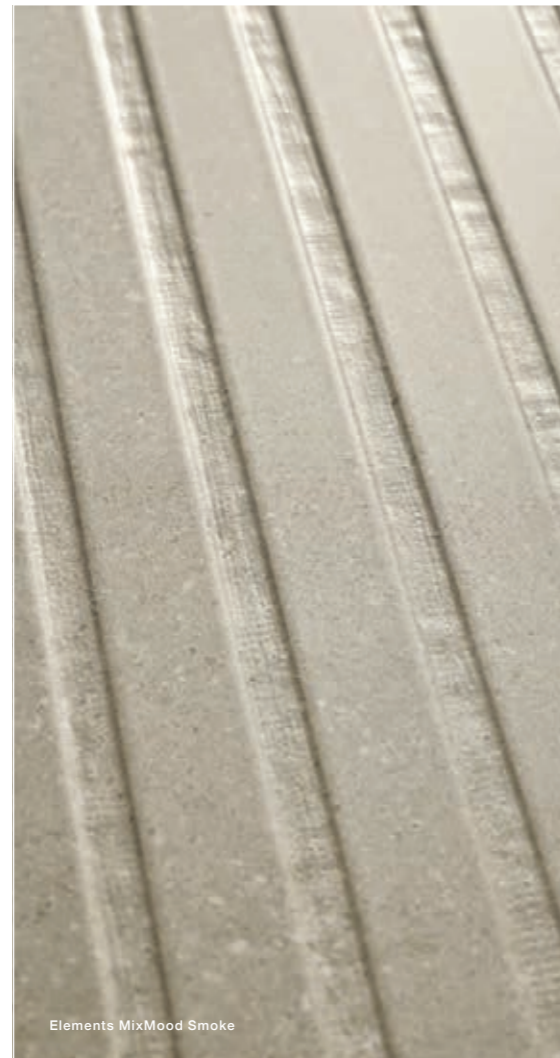

Elements MixMood Smoke



Elements MixPeak Smoke

ZOOM

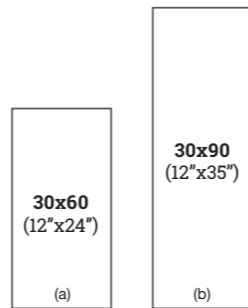

(a) - Elements - Elements MixPeak
(b) - Elements - Elements MixMood - Elements MixPeak

Peças - Pieces		Caixa - Box			Europaleta - Europallet			
		Espessura (mm) Thickness (mm)	Nº Peças No Pieces	M² Aprox. No of Sq. M. Approx.	Peso (Kg) Weight Kg	Nº Caixas No Boxes	M² Aprox. No of Sq. M. Approx.	Peso (Kg) Weight (Kg)
30x60 cm	Rect.	± 9,0 ± 5 %	5	0.90	14.50	72	64.80	1 065
30x90 cm	Rect.	± 12,3 ± 0,5 mm	4	1.08	22.00	40	43.20	901

Elements



Elements Mist
Elements MixPeak Smoke



ELEMENTS MIST
 30x90 RECT [29,6x88,8x1,23 cm] P92
 30x60 RECT [29,6x59,2x0,90 cm] P75



ELEMENTS SMOKE
 30x90 RECT [29,6x88,8x1,23 cm] P92
 30x60 RECT [29,6x59,2x0,90 cm] P75



ELEMENTS FOG
 30x90 RECT [29,6x88,8x1,23 cm] P92
 30x60 RECT [29,6x59,2x0,90 cm] P75

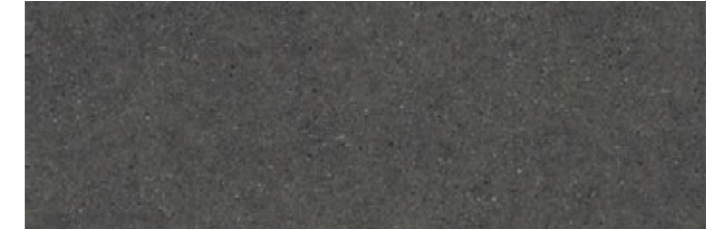

ELEMENTS CARBON
 30x90 RECT [29,6x88,8x1,23 cm] P92
 30x60 RECT [29,6x59,2x0,90 cm] P75



ELEMENTS MIXWOOD MIST (*)
 30x90 RECT [29,6x88,8x1,23 cm] P95



ELEMENTS MIXWOOD SMOKE (*)
 30x90 RECT [29,6x88,8x1,23 cm] P95



ELEMENTS MIXWOOD FOG (*)
 30x90 RECT [29,6x88,8x1,23 cm] P95



ELEMENTS MIXWOOD CARBON (*)
 30x90 RECT [29,6x88,8x1,23 cm] P95



ELEMENTS MIXPEAK MIST (*)
 30x90 RECT [29,6x88,8x1,23 cm] P95
 30x60 RECT [29,6x59,2x0,90 cm] P80



ELEMENTS MIXPEAK SMOKE (*)
 30x90 RECT [29,6x88,8x1,23 cm] P95
 30x60 RECT [29,6x59,2x0,90 cm] P80



ELEMENTS MIXPEAK FOG (*)
 30x90 RECT [29,6x88,8x1,23 cm] P95
 30x60 RECT [29,6x59,2x0,90 cm] P80

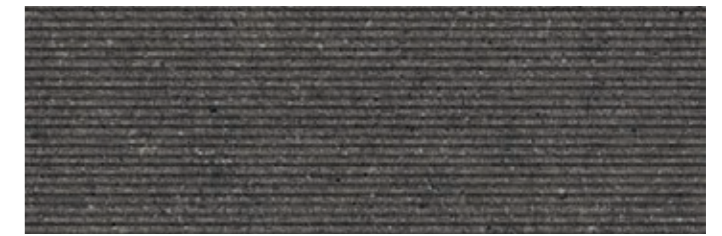

ELEMENTS MIXPEAK CARBON (*)
 30x90 RECT [29,6x88,8x1,23 cm] P95
 30x60 RECT [29,6x59,2x0,90 cm] P80



MULTIFORM ELEMENTS MIST (a)
 30x30 P20 / peça_piece



MULTIFORM ELEMENTS SMOKE (a)
 30x30 P20 / peça_piece



MULTIFORM ELEMENTS FOG (a)
 30x30 P20 / peça_piece



MULTIFORM ELEMENTS CARBON (a)
 30x30 P20 / peça_piece

(*) Dado o efeito deste produto, as peças devem ser aplicadas sempre no mesmo sentido.
 (*) Given the effect of the product, tiles must run in the same direction.
 (*) Poser les carreaux toujours dans le même sens afin de reproduire l'effet recherché de ce produit.
 (*) Debido al efecto de este producto, las piezas se deben aplicar siempre en el mismo sentido.

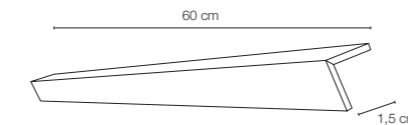

PERFIL ELEMENTS
 1,5x60 RECT [1,5x59,2x0,90 cm] P32 /peça_piece

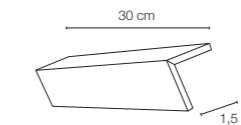

PERFIL ELEMENTS
 1,5x30 RECT [1,5x29,6x0,90 cm] P20 /peça_piece

Perfil: Peças produzidas sob encomenda.
 Perfil: Pieces produced on order.
 Perfil: Pièces produites sur commande.
 Perfil: Piezas producidas por encargo.

Uma solução universal e urbana para revestimentos e pavimentos.
A universal and urban solution for walls and floors.
Une solution universelle et urbaine pour les revêtements muraux et les sols.
Una solución universal y urbana para revestimientos y pavimentos.

Globe

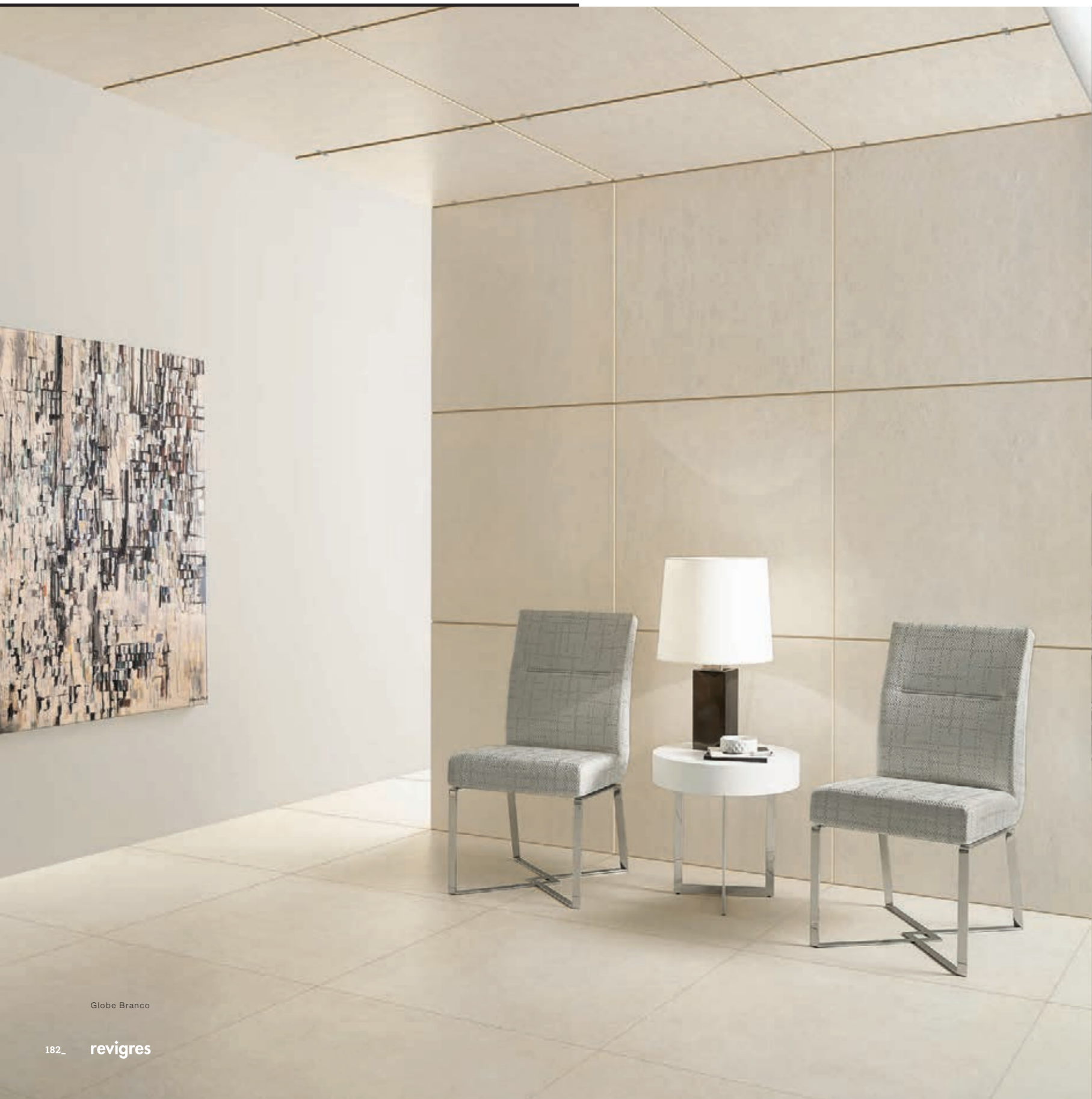

Globe Branco



Globe Branco
Globe Corda

06 cores
colors
couleurs
colores

04 formatos
formats
formats
formats

02 acabamentos
finishes
finitions
acabados



GRAPHIC VARIATION

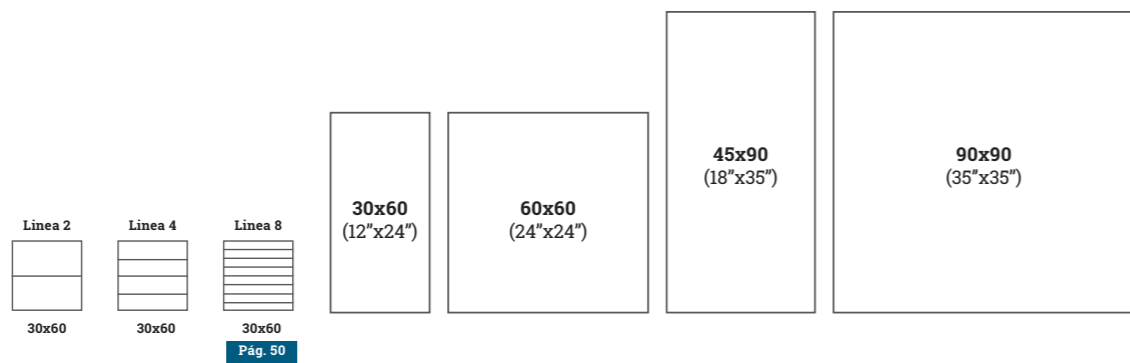

Peças / Pieces		Espessura (mm) Thickness (mm)	Caixa / Box			Europalet / Europallet		
30x60 cm	Rect.		Nº Peças No Pieces	M² Aprox. No of Sq. M. Approx.	Peso (Kg) Weight Kg	Nº Caixas No Boxes	M² Aprox. No of Sq. M. Approx.	Peso (Kg) Weight (Kg)
30x60 cm	Rect.	± 8,5 ±5%	5	0.90	18.0	60	54.00	1 101
60x60 cm	Rect.	± 8,5 ±5%	4	1.44	28.7	36	51.84	1 053
45x90 cm	Rect.	± 10,5 ±0,5 mm	4	1.62	39.0	27	43.74	1 074
90x90 cm	Rect.	± 10,5 ±0,5 mm	2	1.62	39.0	24	38.88	991





GLOBE BRANCO

90x90	RECT	[89,0x89,0x1,05 cm]	P109	V2	4	class 1	A	R9	-	≥0,42
60x60	RECT	[59,2x59,2x0,85 cm]	P87	V2	4	class 1	A	R9	-	≥0,42
45x90	RECT	[44,5x89,0x1,05 cm]	P94	V2	4	class 1	A	R9	-	≥0,42
30x60	RECT	[29,6x59,2x0,85 cm]	P87	V2	4	class 1	A	R9	-	≥0,42

ANTISLIP GLOBE BRANCO

60x60	RECT	[59,2x59,2x0,85 cm]	P87	V2	4	class 3	B	R11	36+	≥0,42
-------	------	-----------------------	-----	----	---	---------	---	-----	-----	-------

GLOBE CORDA

90x90	RECT	[89,0x89,0x1,05 cm]	P109	V2	4	class 1	A	R9	-	≥0,42
60x60	RECT	[59,2x59,2x0,85 cm]	P87	V2	4	class 1	A	R9	-	≥0,42
45x90	RECT	[44,5x89,0x1,05 cm]	P94	V2	4	class 1	A	R9	-	≥0,42
30x60	RECT	[29,6x59,2x0,85 cm]	P87	V2	4	class 1	A	R9	-	≥0,42

ANTISLIP GLOBE CORDA

60x60	RECT	[59,2x59,2x0,85 cm]	P87	V2	4	class 3	B	R11	36+	≥0,42
-------	------	-----------------------	-----	----	---	---------	---	-----	-----	-------

GLOBE GRAFITE

90x90	RECT	[89,0x89,0x1,05 cm]	P109	V2	4	class 1	A	R9	-	≥0,42
60x60	RECT	[59,2x59,2x0,85 cm]	P87	V2	4	class 1	A	R9	-	≥0,42
45x90	RECT	[44,5x89,0x1,05 cm]	P94	V2	4	class 1	A	R9	-	≥0,42
30x60	RECT	[29,6x59,2x0,85 cm]	P87	V2	4	class 1	A	R9	-	≥0,42

ANTISLIP GLOBE GRAFITE

60x60	RECT	[59,2x59,2x0,85 cm]	P87	V2	4	class 3	B	R11	36+	≥0,42
-------	------	-----------------------	-----	----	---	---------	---	-----	-----	-------

GLOBE FOG

90x90	RECT	[89,0x89,0x1,05 cm]	P109	V2	4	class 1	A	R9	-	≥0,42
60x60	RECT	[59,2x59,2x0,85 cm]	P87	V2	4	class 1	A	R9	-	≥0,42
45x90	RECT	[44,5x89,0x1,05 cm]	P94	V2	4	class 1	A	R9	-	≥0,42
30x60	RECT	[29,6x59,2x0,85 cm]	P87	V2	4	class 1	A	R9	-	≥0,42

ANTISLIP GLOBE FOG

60x60	RECT	[59,2x59,2x0,85 cm]	P87	V2	4	class 3	B	R11	36+	≥0,42
-------	------	-----------------------	-----	----	---	---------	---	-----	-----	-------

Antislip: Produtos que minimizam o risco de deslizamento.
 Antislip: Products that minimize the risk of slipping.
 Antislip: Produits qui réduisent le risque de glissement.
 Antislip: Productos que minimizan el riesgo de deslizamiento.



GLOBE GRIS

90x90	RECT	[89,0x89,0x1,05 cm]	P109	V2	4	class 1	A	R9	-	≥0,42
60x60	RECT	[59,2x59,2x0,85 cm]	P87	V2	4	class 1	A	R9	-	≥0,42
45x90	RECT	[44,5x89,0x1,05 cm]	P94	V2	4	class 1	A	R9	-	≥0,42
30x60	RECT	[29,6x59,2x0,85 cm]	P87	V2	4	class 1	A	R9	-	≥0,42

ANTISLIP GLOBE GRIS

60x60	RECT	[59,2x59,2x0,85 cm]	P87	V2	4	class 3	B	R11	36+	≥0,42
-------	------	-----------------------	-----	----	---	---------	---	-----	-----	-------

GLOBE ANTRACITE

90x90	RECT	[89,0x89,0x1,05 cm]	P109	V2	4	class 1	A	R9	-	≥0,42
60x60	RECT	[59,2x59,2x0,85 cm]	P87	V2	4	class 1	A	R9	-	≥0,42
45x90	RECT	[44,5x89,0x1,05 cm]	P94	V2	4	class 1	A	R9	-	≥0,42
30x60	RECT	[29,6x59,2x0,85 cm]	P87	V2	4	class 1	A	R9	-	≥0,42

ANTISLIP GLOBE ANTRACITE

60x60	RECT	[59,2x59,2x0,85 cm]	P87	V2	4	class 3	B	R11	36+	≥0,42
-------	------	-----------------------	-----	----	---	---------	---	-----	-----	-------

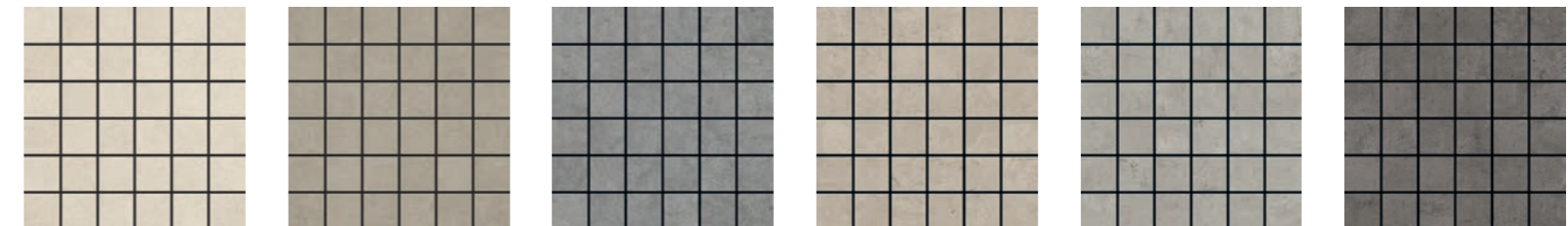

STRATUS 36 GLOBE BRANCO (a) (f) 30x30 P19 / peça_pieça
 STRATUS 36 GLOBE CORDA (a) (f) 30x30 P19 / peça_pieça
 STRATUS 36 GLOBE GRAFITE (a) (f) 30x30 P19 / peça_pieça
 STRATUS 36 GLOBE FOG (a) (f) 30x30 P19 / peça_pieça
 STRATUS 36 GLOBE GRIS (a) (f) 30x30 P19 / peça_pieça
 STRATUS 36 GLOBE ANTRACITE (a) (f) 30x30 P19 / peça_pieça

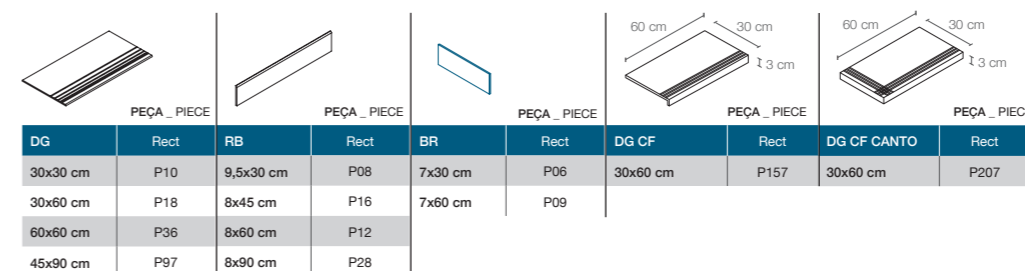

DG CF / DG CF Canto: Peças produzidas sob encomenda.
 DG CF / DG CF Canto: Pièces produced on order.
 DG CF / DG CF Canto: Pièces produites sur commande
 DG CF / DG CF Canto: Piezas producidas por encargo

DG CF Canto: Disponível em canto esquerdo e direito.
 DG CF Canto: Available in left and right corner.
 DG CF Canto: Disponible en angle gauche et droit.
 DG CF Canto: Canto izquierdo y derecho disponibles.

Revestimentos contemporâneos com um toque revivalista.
Modern wall tiles with vintage design.
Des revêtements contemporains avec une touche revivaliste.
Revestimientos contemporâneos con un toque retro.

Silken



Silken Rubi
Forest White
Forest Nude



Silken Fog
Silken Antracite
Cross 36 Silken Antracite
Cross 36 Silken Fog
Globe Fog
Globe Antracite

Silken

10 cores
colors
couleurs
colores

01 formato
format
format
formato

01 acabamento
finish
finition
acabado



Silken Bege

[ZOOM](#)



Silken Antracite
Cross 36 Silken Antracite

30x60
(12"x24")

Peças / Pieces		Caixa / Box			Europaleta / Europallet			
30x60 cm	Rect.	Espessura (mm) Thickness (mm)	Nº Peças No Pieces	M² Aprox. No of Sq. M. Approx.	Peso (Kg) Weight Kg	Nº Caixas No Boxes	M² Aprox. No of Sq. M. Approx.	Peso (Kg) Weight (Kg)
		± 9,0 ± 5 %	5	0,9	14,5	72	64,8	1 065

Silken



Silken Ocean
Silken Branco
Globe Branco

Silken



SILKEN BRANCO
30x60 RECT [29,6x59,2x0,90 cm] P75

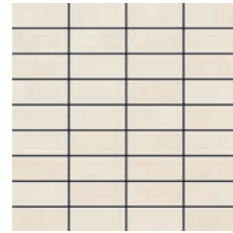

CROSS 36 SILKEN BRANCO (a)
30x30 P17 / peça_piece



SILKEN GRIS
30x60 RECT [29,6x59,2x0,90 cm] P75

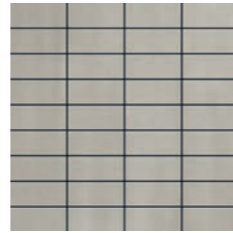

CROSS 36 SILKEN GRIS (a)
30x30 P17 / peça_piece



SILKEN BEGE
30x60 RECT [29,6x59,2x0,90 cm] P75

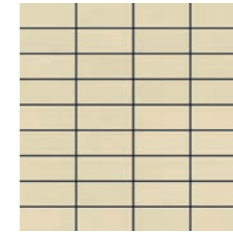

CROSS 36 SILKEN BEGE (a)
30x30 P17 / peça_piece



SILKEN JADE
30x60 RECT [29,6x59,2x0,90 cm] P75

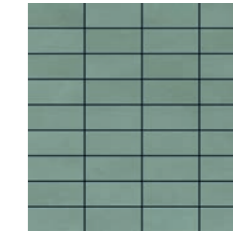

CROSS 36 SILKEN JADE (a)
30x30 P17 / peça_piece

Silken



SILKEN FOG
30x60 RECT [29,6x59,2x0,90 cm] P75

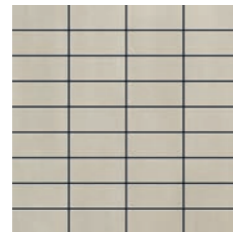

CROSS 36 SILKEN FOG (a)
30x30 P17 / peça_piece



SILKEN ANTRACITE
30x60 RECT [29,6x59,2x0,90 cm] P75



CROSS 36 SILKEN ANTRACITE (a)
30x30 P17 / peça_piece



SILKEN OCEAN
30x60 RECT [29,6x59,2x0,90 cm] P75

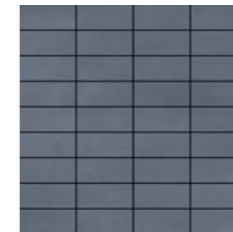

CROSS 36 SILKEN OCEAN (a)
30x30 P17 / peça_piece



SILKEN CARAMEL
30x60 RECT [29,6x59,2x0,90 cm] P75

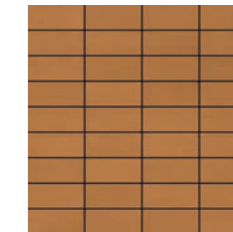

CROSS 36 SILKEN CARAMEL (a)
30x30 P17 / peça_piece



SILKEN CORDA
30x60 RECT [29,6x59,2x0,90 cm] P75

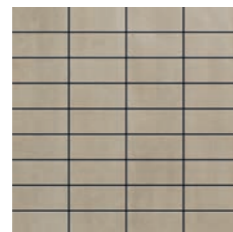

CROSS 36 SILKEN CORDA (a)
30x30 P17 / peça_piece



SILKEN RUBI
30x60 RECT [29,6x59,2x0,90 cm] P90

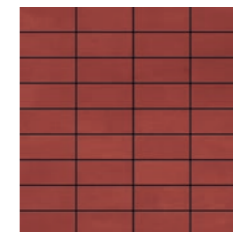

CROSS 36 SILKEN RUBI (a)
30x30 P17 / peça_piece

COORDENADOS · MATCHING · COORDONNÉS · COORDINADOS



GLOBE BRANCO
60x60 RECT [59,2x59,2x0,85 cm] P87

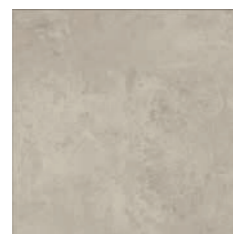

GLOBE FOG
60x60 RECT [59,2x59,2x0,85 cm] P87

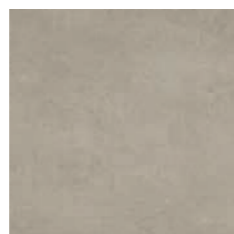

GLOBE CORDA
60x60 RECT [59,2x59,2x0,85 cm] P87



GLOBE GRIS
60x60 RECT [59,2x59,2x0,85 cm] P87

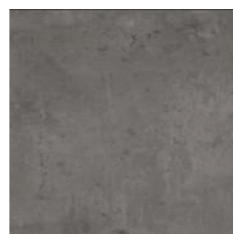

GLOBE ANTRACITE
60x60 RECT [59,2x59,2x0,85 cm] P87

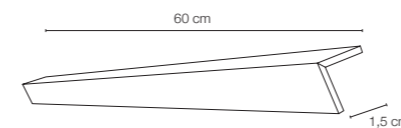

PERFIL SILKEN
1,5x60 RECT [1,5x59,2x0,90 cm] P32 /peça_piece

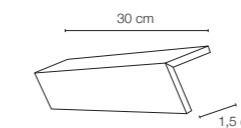

PERFIL SILKEN
1,5x30 RECT [1,5x29,6x0,90 cm] P20 /peça_piece

Perfil: Peças produzidas sob encomenda.
 Perfil: Pieces produced on order.
 Perfil: Pièces produites sur commande.
 Perfil: Piezas producidas por encargo.



ATELIER OCRE (*)
30x60 RECT | [29,6x59,2x0,90 cm] P80



ATELIER OLIVA (*)
30x60 RECT | [29,6x59,2x0,90 cm] P80



ATELIER TERRACOTTA (*)
30x60 RECT | [29,6x59,2x0,90 cm] P80



MINIMAL GRIS
30x60 RECT | [29,6x59,2x0,90 cm] P80



(*) Existem 2 peças diferentes, de acordo com o desenho do decorado, que devem ser aplicadas alternadamente, de modo a obter-se uma solução mais rica e variada.
 (*) There are 2 pieces, matching the design of the decorated tiles, which should be applied alternately in order to obtain a richer and more varied decoration.
 (*) 2 pièces correspondent au dessin du décor. Il convient de les appliquer de façon alternée pour obtenir une disposition plus riche et plus variée.
 (*) Existen 2 piezas diferentes, de acuerdo con el diseño del decorado, que deben aplicarse de forma alterna, con el fin de obtener una solución más y variada.

A união entre a força do cimento e a riqueza da cor.
Marriage between the strength of cement and the richness of colour.
L'union entre la force du ciment et la richesse de la couleur.
La unión entre la fuerza del cemento y la riqueza del color.

Planet



Nimbus Fog
Impressions Mix Gris
Planet Gris
Planet Fog



Planet Gris
Planet Platina

06 cores
colors
couleurs
colores

01 formato
format
format
formato

01 acabamento
finish
finition
acabado

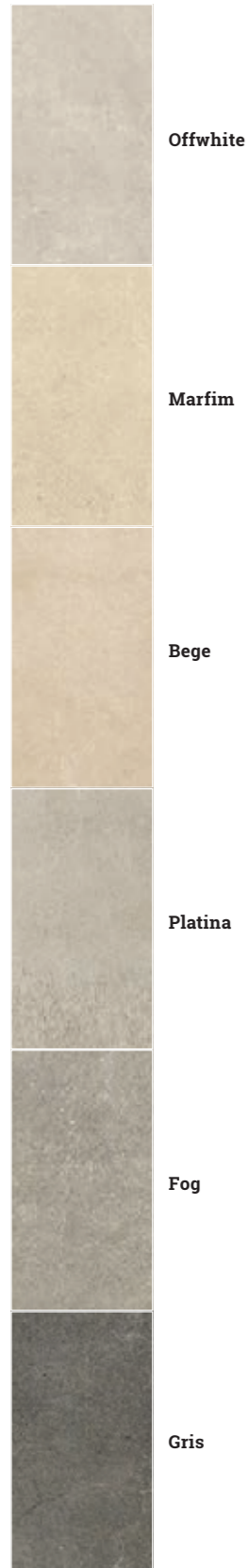

GRAPHIC VARIATION

60x60
(24"x24")

Peças / Pieces		Caixa / Box			Europaleta / Europallet			
60x60 cm	Rect.	Espesura (mm) Thickness (mm)	Nº Peças No Pieces	M² Aprox. No of Sq. M. Approx.	Peso (Kg) Weight Kg	Nº Caixas No Boxes	M² Aprox. No of Sq. M. Approx.	Peso (Kg) Weight (Kg)
		± 8,5 ±5%	4	1.44	28.7	36	51.84	1 053



Nimbus Bege
Nimbus Marfim
Nimbus Block Marfim
Stratus 36 Nimbus Mix Bege
Planet Bege



PLANET OFFWHITE										
60x60	RECT	[59,2x59,2x0,85 cm]	P87	V3	4	class 1	A	R9	≥0,42	



PLANET MARFIM										
60x60	RECT	[59,2x59,2x0,85 cm]	P87	V3	4	class 1	A	R9	≥0,42	

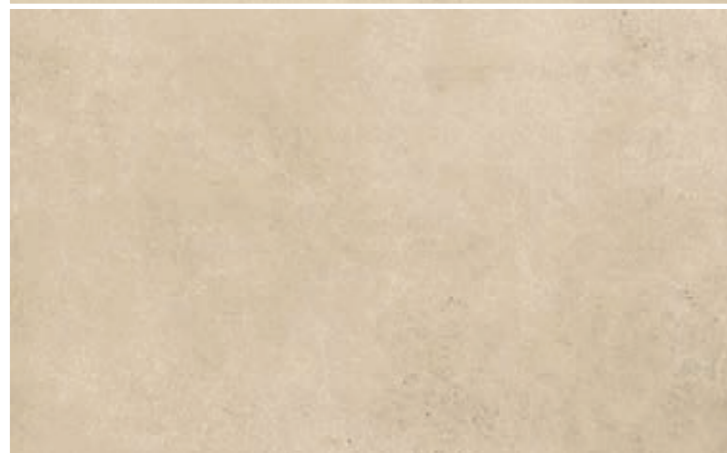

PLANET BEGE										
60x60	RECT	[59,2x59,2x0,85 cm]	P87	V3	4	class 1	A	R9	≥0,42	



PLANET PLATINA										
60x60	RECT	[59,2x59,2x0,85 cm]	P87	V3	4	class 1	A	R9	≥0,42	



PLANET FOG										
60x60	RECT	[59,2x59,2x0,85 cm]	P87	V3	4	class 1	A	R9	≥0,42	



PLANET GRIS										
60x60	RECT	[59,2x59,2x0,85 cm]	P87	V3	4	class 1	A	R9	≥0,42	



STRATUS 36
PLANET OFFWHITE (a) (f)
30x30 P19 / peça_pieza

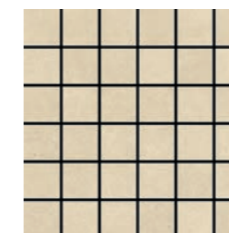

STRATUS 36
PLANET MARFIM (a) (f)
30x30 P19 / peça_pieza

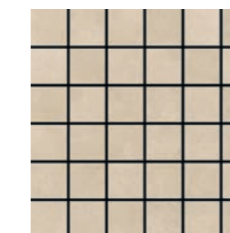

STRATUS 36
PLANET BEGE (a) (f)
30x30 P19 / peça_pieza



STRATUS 36
PLANET PLATINA (a) (f)
30x30 P19 / peça_pieza



STRATUS 36
PLANET FOG (a) (f)
30x30 P19 / peça_pieza

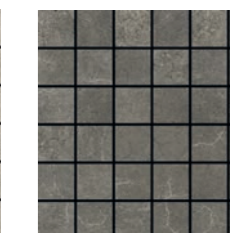

STRATUS 36
PLANET GRIS (a) (f)
30x30 P19 / peça_pieza

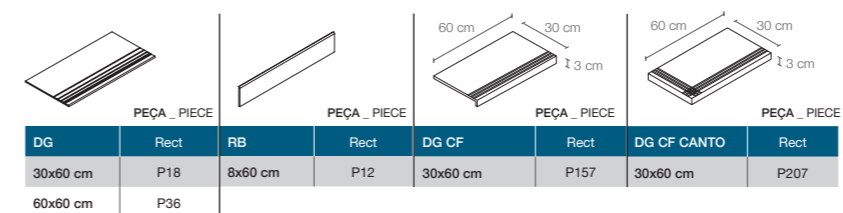

DG CF / DG CF Canto: Peças produzidas sob encomenda.
DG CF / DG CF Canto: Pieces produced on order.
DG CF / DG CF Canto: Pièces produites sur commande
DG CF / DG CF Canto: Piezas producidas por encargo

DG CF Canto: Disponível em canto esquerdo e direito.
DG CF Canto: Available in left and right corner.
DG CF Canto: Disponible en angle gauche et droit.
DG CF Canto: Canto izquierdo y derecho disponibles.

A versatilidade do cimento em superfícies lisas e em 3D.
Cement versatility on smooth surfaces and in 3D.
La versatilité du ciment sur des surfaces lisses et à 3D.
La versatilidad del cemento sobre superficies lisas y en 3D.

Nimbus



Nimbus Block Offwhite



Nimbus Gris
Nimbus Block Gris
Exotic Âmbar

Nimbus

Nimbus

- 06** cores
couleurs
colores
- 02** formatos
formats
formatos
- 01** acabamento
finish
finition
acabado

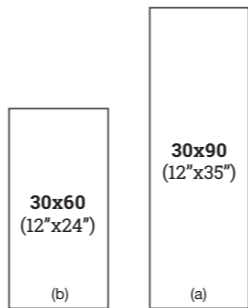
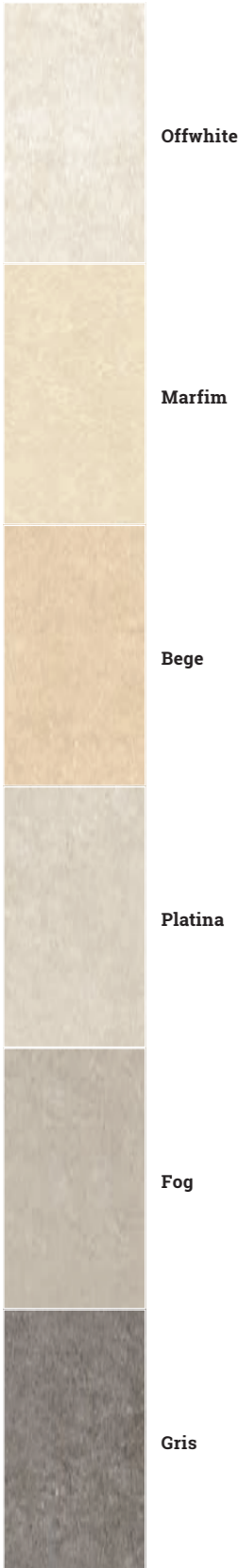

(a) - Nimbus · Nimbus Block
(b) - Nimbus · Impressions · Solids

Peças - Pieces		Caixa - Box			Europaleta - Europallet		
	Espessura (mm) Thickness (mm)	Nº Peças No Pieces	M² Aprox. No of Sq. M. Approx.	Peso (Kg) Weight Kg	Nº Caixas No Boxes	M² Aprox. No of Sq. M. Approx.	Peso (Kg) Weight (Kg)
30x60 cm	Rect. ± 9,0 ± 5 %	5	0.90	14.5	72	64.8	1 065
30x90 cm	Rect. ± 12,3 ± 0,5 mm	4	1.08	22.0	40	43.2	901

Nimbus



Nimbus



NIMBUS OFFWHITE
 30x90 RECT [29,6x88,8x1,23 cm] P92
 30x60 RECT [29,6x59,2x0,90 cm] P75



NIMBUS BLOCK OFFWHITE (*)
 30x90 RECT [29,6x88,8x1,23 cm] P95



NIMBUS PLATINA
 30x90 RECT [29,6x88,8x1,23 cm] P92
 30x60 RECT [29,6x59,2x0,90 cm] P75



NIMBUS BLOCK PLATINA (*)
 30x90 RECT [29,6x88,8x1,23 cm] P95



NIMBUS MARFIM
 30x90 RECT [29,6x88,8x1,23 cm] P92
 30x60 RECT [29,6x59,2x0,90 cm] P75



NIMBUS BLOCK MARFIM (*)
 30x90 RECT [29,6x88,8x1,23 cm] P95



NIMBUS FOG
 30x90 RECT [29,6x88,8x1,23 cm] P92
 30x60 RECT [29,6x59,2x0,90 cm] P75



NIMBUS BLOCK FOG (*)
 30x90 RECT [29,6x88,8x1,23 cm] P95

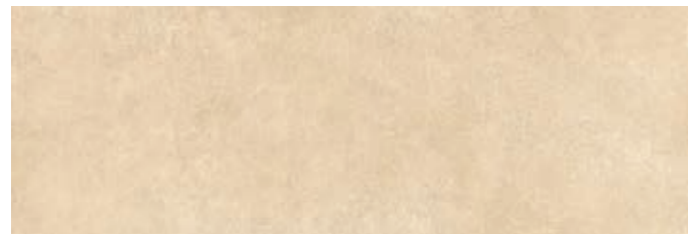

NIMBUS BEGE
 30x90 RECT [29,6x88,8x1,23 cm] P92
 30x60 RECT [29,6x59,2x0,90 cm] P75

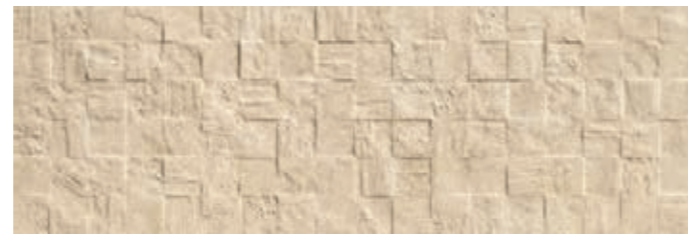

NIMBUS BLOCK BEGE (*)
 30x90 RECT [29,6x88,8x1,23 cm] P95

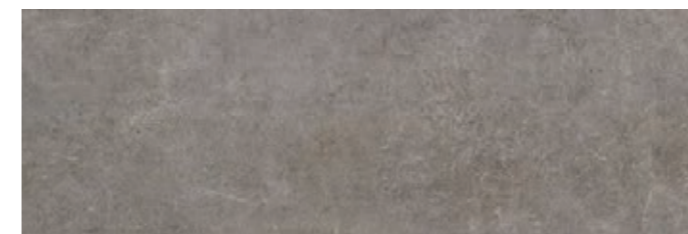

NIMBUS GRIS
 30x90 RECT [29,6x88,8x1,23 cm] P92
 30x60 RECT [29,6x59,2x0,90 cm] P75



NIMBUS BLOCK GRIS (*)
 30x90 RECT [29,6x88,8x1,23 cm] P95

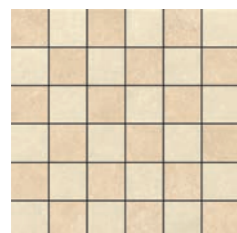

STRATUS 36 NIMBUS MIX BEGE (a)
 30x30 P17 / peça_piece



STRATUS 36 NIMBUS MIX GRIS (a)
 30x30 P17 / peça_piece

COORDENADOS · MATCHING · COORDONNÉS · COORDINADOS

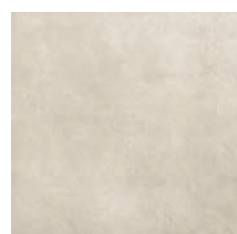

PLANET OFFWHITE
 60x60 RECT [59,2x59,2x0,85 cm] P87



PLANET MARFIM
 60x60 RECT [59,2x59,2x0,85 cm] P87

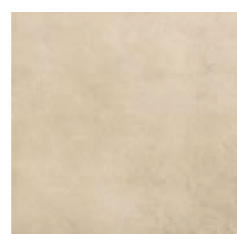

PLANET BEGE
 60x60 RECT [59,2x59,2x0,85 cm] P87

(*) Dado o efeito deste produto, as peças devem ser aplicadas sempre no mesmo sentido.

(*) Given the effect of the product, tiles must run in the same direction.

(*) Poser les carreaux toujours dans le même sens afin de reproduire l'effet recherché de ce produit.

(*) Debido al efecto de este producto, las piezas se deben aplicar siempre en el mismo sentido.

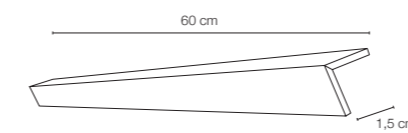

PERFIL NIMBUS
 1,5x60 RECT [1,5x59,2x0,90 cm] P32 /peça_piece

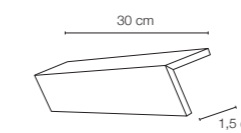

PERFIL NIMBUS
 1,5x30 RECT [1,5x29,6x0,90 cm] P20 /peça_piece

Perfil: Peças produzidas sob encomenda.
 Perfil: Pieces produced on order.
 Perfil: Pièces produites sur commande.
 Perfil: Piezas producidas por encargo.

COORDENADOS · MATCHING · COORDONNÉS · COORDINADOS

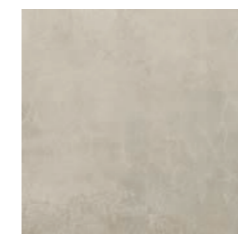

PLANET PLATINA
 60x60 RECT [59,2x59,2x0,85 cm] P87

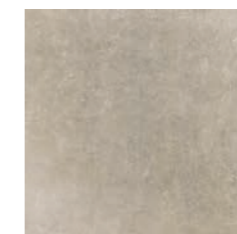

PLANET FOG
 60x60 RECT [59,2x59,2x0,85 cm] P87



PLANET GRIS
 60x60 RECT [59,2x59,2x0,85 cm] P87



IMPRESSIONS MIX BEGE (*)
30x60 RECT [29,6x59,2x0,90 cm] P80



IMPRESSIONS MIX GRIS (*)
30x60 RECT [29,6x59,2x0,90 cm] P80



SOLIDS MIX BEGE
30x60 RECT [29,6x59,2x0,90 cm] P80

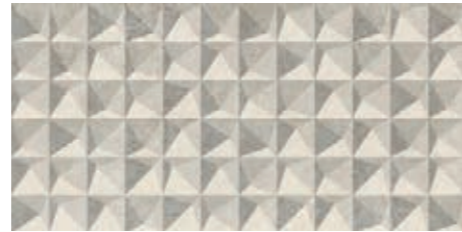

SOLIDS MIX GRIS
30x60 RECT [29,6x59,2x0,90 cm] P80

(*) Existem 2 peças diferentes, de acordo com o desenho do decorado, que devem ser aplicadas alternadamente, de modo a obter-se uma solução mais rica e variada.
 (*) There are 2 pieces, matching the design of the decorated tiles, which should be applied alternately in order to obtain a richer and more varied decoration.
 (*) 2 pièces correspondent au dessin du décor. Il convient de les appliquer de façon alternée pour obtenir une disposition plus riche et plus variée.
 (*) Existen 2 piezas diferentes, de acuerdo con el diseño del decorado, que deben aplicarse de forma alterna, con el fin de obtener una solución más y variada.



Impressions Mix Bege
Forest Bege
Antislip Forest Bege

Concrete

Concrete

Inspirada na paisagem de betão das grandes metrópoles.
Inspired by the concrete landscape of large cities.
Inspiré par le paysage de béton des grandes métropoles.
Inspirada en el paisaje de hormigón de las grandes metrópolis.

Urban



Urban Bone



Urban Fog
Hydraulik Fog

06 cores colors couleurs
07 formatos formats formats
02 acabamentos finishes finitions acabados



12
Até 12 desenhos
Up to 12 designs
Jusqu'à 12 dessins
Hasta 12 diseños

NEW 60x60 (24"x24") (a)

NEW 60x120 (24"x47") (b)

NEW 45x90 (18"x35") (b)

NEW 90x90 (35"x35") (b)

NEW 30x60 (12"x24") (b)

NEW 30x30 (12"x12") (b)

(a) - Urban - Antislip Urban
(b) - Urban
(c) - Urban - Hydraulik

45x45 (18"x18") (c)

Linea 2 30x60
Linea 4 30x60
Linea 8 30x60

Pág. 50

Peças / Pieces	Espessura (mm) Thickness (mm)	Caixa / Box			Europalet / Europalet		
		Nº Peças No Pieces	M² Aprox. No of Sq. M. Approx.	Peso (Kg) Weight Kg	Nº Caixas No Boxes	M² Aprox. No of Sq. M. Approx.	Peso (Kg) Weight (Kg)
30x30 cm	Nat.	10	0.90	17.5	64	57.60	1 141
	Rect.	10	0.90	18.0	64	57.60	1 173
45x45 cm	Nat.	6	1.22	24.0	34	41.48	837
	Rect.	6	1.22	24.0	34	41.48	837
30x60 cm	Nat.	5	0.90	18.0	48	43.20	885
	Rect.	5	0.90	18.0	60	54.00	1 101
60x60 cm	Rect.	4	1.44	28.7	36	51.84	1 053
90x90 cm	Rect.	2	1.62	39.0	24	38.88	991
45x90 cm	Rect.	4	1.62	39.0	27	43.74	1 074
60x120 cm	Rect.	2	1.44	33.0	30	43.20	1 011





URBAN OFFWHITE										
90x90	RECT	[89,0x89,0x1,05 cm]	P109	V2	class 1	A	R9	—	≥0,42	—
60x60	RECT	[59,2x59,2x0,85 cm]	P87	V2	class 1	A	R9	—	≥0,42	U4P4E3C2
60x120	RECT	[59,2x118,4x0,98 cm]	P109	V2	class 1	A	R9	—	≥0,42	—
45x90	RECT	[44,5x89,0x1,05 cm]	P94	V2	class 1	A	R9	—	≥0,42	—
45x45	NAT	[...x0,85 cm]	P69	V2	class 1	A	R9	—	≥0,42	U4P4E3C2
	RECT	[44,4x44,4x0,85 cm]	P79	V2	class 1	A	R9	—	≥0,42	U4P4E3C2
30x60	NAT	[...x0,85 cm]	P69	V2	class 1	A	R9	—	≥0,42	U4P3E3C2
	RECT	[29,6x59,2x0,85 cm]	P79	V2	class 1	A	R9	—	≥0,42	U4P3E3C2
30x30	NAT	[...x0,77 cm]	P66	V2	class 1	A	R9	—	≥0,42	—
	RECT	[29,6x29,6x0,77cm]	P76	V2	class 1	A	R9	—	≥0,42	—

ANTISLIP URBAN OFFWHITE										
60x60	RECT	[59,2x59,2x0,85 cm]	P87	V2	class 3	B	R11	36+	≥0,42	—



URBAN FOG										
90x90	RECT	[89,0x89,0x1,05 cm]	P109	V2	class 1	A	R9	—	≥0,42	—
60x60	RECT	[59,2x59,2x0,85 cm]	P87	V2	class 1	A	R9	—	≥0,42	U4P4E3C2
60x120	RECT	[59,2x118,4x0,98 cm]	P109	V2	class 1	A	R9	—	≥0,42	—
45x90	RECT	[44,5x89,0x1,05 cm]	P94	V2	class 1	A	R9	—	≥0,42	—
45x45	NAT	[...x0,85 cm]	P69	V2	class 1	A	R9	—	≥0,42	U4P4E3C2
	RECT	[44,4x44,4x0,85 cm]	P79	V2	class 1	A	R9	—	≥0,42	U4P4E3C2
30x60	NAT	[...x0,85 cm]	P69	V2	class 1	A	R9	—	≥0,42	U4P3E3C2
	RECT	[29,6x59,2x0,85 cm]	P79	V2	class 1	A	R9	—	≥0,42	U4P3E3C2
30x30	NAT	[...x0,77 cm]	P66	V2	class 1	A	R9	—	≥0,42	—
	RECT	[29,6x29,6x0,77cm]	P76	V2	class 1	A	R9	—	≥0,42	—

ANTISLIP URBAN FOG										
60x60	RECT	[59,2x59,2x0,85 cm]	P87	V2	class 3	B	R11	36+	≥0,42	—

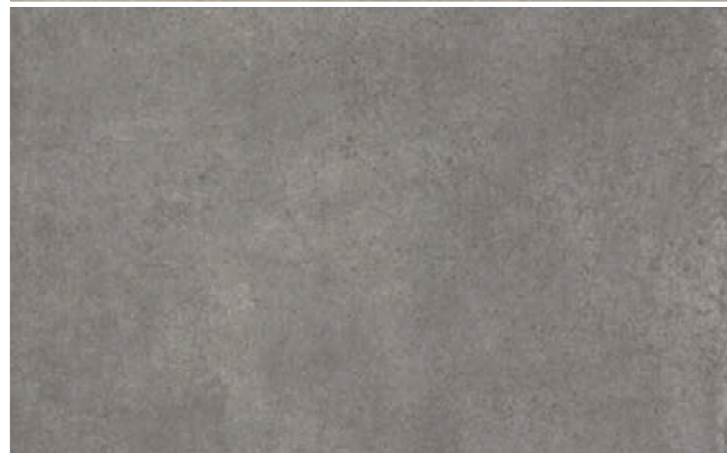

URBAN GRIS										
90x90	RECT	[89,0x89,0x1,05 cm]	P109	V2	class 1	A	R9	—	≥0,42	—
60x60	RECT	[59,2x59,2x0,85 cm]	P87	V2	class 1	A	R9	—	≥0,42	U4P4E3C2
60x120	RECT	[59,2x118,4x0,98 cm]	P109	V2	class 1	A	R9	—	≥0,42	—
45x90	RECT	[44,5x89,0x1,05 cm]	P94	V2	class 1	A	R9	—	≥0,42	—
45x45	NAT	[...x0,85 cm]	P69	V2	class 1	A	R9	—	≥0,42	U4P4E3C2
	RECT	[44,4x44,4x0,85 cm]	P79	V2	class 1	A	R9	—	≥0,42	U4P4E3C2
30x60	NAT	[...x0,85 cm]	P69	V2	class 1	A	R9	—	≥0,42	U4P3E3C2
	RECT	[29,6x59,2x0,85 cm]	P79	V2	class 1	A	R9	—	≥0,42	U4P3E3C2
30x30	NAT	[...x0,77 cm]	P66	V2	class 1	A	R9	—	≥0,42	—
	RECT	[29,6x29,6x0,77cm]	P76	V2	class 1	A	R9	—	≥0,42	—

ANTISLIP URBAN GRIS										
60x60	RECT	[59,2x59,2x0,85 cm]	P87	V2	class 3	B	R11	36+	≥0,42	—



URBAN BONE										
90x90	RECT	[89,0x89,0x1,05 cm]	P109	V2	class 1	A	R9	—	≥0,42	—
60x60	RECT	[59,2x59,2x0,85 cm]	P87	V2	class 1	A	R9	—	≥0,42	U4P4E3C2
60x120	RECT	[59,2x118,4x0,98 cm]	P109	V2	class 1	A	R9	—	≥0,42	—
45x90	RECT	[44,5x89,0x1,05 cm]	P94	V2	class 1	A	R9	—	≥0,42	—
45x45	NAT	[...x0,85 cm]	P69	V2	class 1	A	R9	—	≥0,42	U4P4E3C2
	RECT	[44,4x44,4x0,85 cm]	P79	V2	class 1	A	R9	—	≥0,42	U4P4E3C2
30x60	NAT	[...x0,85 cm]	P69	V2	class 1	A	R9	—	≥0,42	U4P3E3C2
	RECT	[29,6x59,2x0,85 cm]	P79	V2	class 1	A	R9	—	≥0,42	U4P3E3C2
30x30	NAT	[...x0,77 cm]	P66	V2	class 1	A	R9	—	≥0,42	—
	RECT	[29,6x29,6x0,77cm]	P76	V2	class 1	A	R9	—	≥0,42	—

ANTISLIP URBAN BONE										
60x60	RECT	[59,2x59,2x0,85 cm]	P87	V2	class 3	B	R11	36+	≥0,42	—



URBAN CRAFT										
90x90	RECT	[89,0x89,0x1,05 cm]	P109	V2	class 1	A	R9	—	≥0,42	—
60x60	RECT	[59,2x59,2x0,85 cm]	P87	V2	class 1	A	R9	—	≥0,42	U4P4E3C2
60x120	RECT	[59,2x118,4x0,98 cm]	P109	V2	class 1	A	R9	—	≥0,42	—
45x90	RECT	[44,5x89,0x1,05 cm]	P94	V2	class 1	A	R9	—	≥0,42	—
45x45	NAT	[...x0,85 cm]	P69	V2	class 1	A	R9	—	≥0,42	U4P4E3C2
	RECT	[44,4x44,4x0,85 cm]	P79	V2	class 1	A	R9	—	≥0,42	U4P4E3C2
30x60	NAT	[...x0,85 cm]	P69	V2	class 1	A	R9	—	≥0,42	U4P3E3C2
	RECT	[29,6x59,2x0,85 cm]	P79	V2	class 1	A	R9	—	≥0,42	U4P3E3C2
30x30	NAT	[...x0,77 cm]	P66	V2	class 1	A	R9	—	≥0,42	—
	RECT	[29,6x29,6x0,77cm]	P76	V2	class 1	A	R9	—	≥0,42	—

ANTISLIP URBAN CRAFT										
60x60	RECT	[59,2x59,2x0,85 cm]	P87	V2	class 3	B	R11	36+	≥0,42	—



URBAN ANTRACITE ◆ NEW										
90x90	RECT	[89,0x89,0x1,05 cm]	P109	V2	class 1	A	R9	—	≥0,42	—
60x60	RECT	[59,2x59,2x0,85 cm]	P87	V2	class 1	A	R9	—	≥0,42	U4P4E3C2
60x120	RECT	[59,2x118,4x0,98 cm]	P109	V2	class 1	A	R9	—	≥0,42	—
45x90	RECT	[44,5x89,0x1,05 cm]	P94	V2	class 1	A	R9	—	≥0,42	—
45x45	NAT	[...x0,85 cm]	P69	V2	class 1	A	R9	—	≥0,42	U4P4E3C2
	RECT	[44,4x44,4x0,85 cm]	P79	V2	class 1	A	R9	—	≥0,42	U4P4E3C2
30x60	NAT	[...x0,85 cm]	P69	V2	class 1	A	R9	—	≥0,42	U4P3E3C2
	RECT	[29,6x59,2x0,85 cm]	P79	V2	class 1	A	R9	—	≥0,42	U4P3E3C2
30x30	NAT	[...x0,77 cm]	P66	V2	class 1	A	R9	—	≥0,42	—
	RECT	[29,6x29,6x0,77cm]	P76	V2	class 1	A	R9	—	≥0,42	—

ANTISLIP URBAN ANTRACITE										
60x60	RECT	[59,2x59,2x0,85 cm]	P87	V2	class 3	B	R11	36+	≥0,42	—

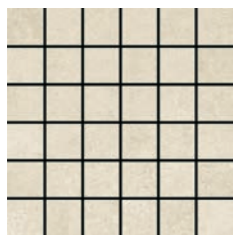

STRATUS 36
URBAN OFFWHITE (a) (f)
30x30 P19 /peça_pieza

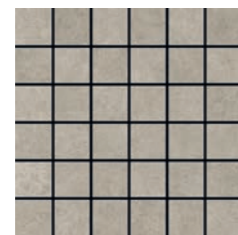

STRATUS 36
URBAN FOG (a) (f)
30x30 P19 /peça_pieza

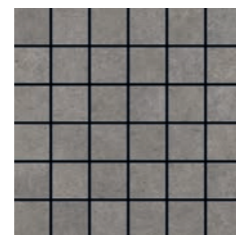

STRATUS 36
URBAN GRIS (a) (f)
30x30 P19 /peça_pieza

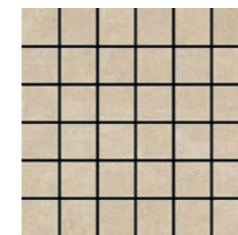

STRATUS 36
URBAN BONE (a) (f)
30x30 P19 /peça_pieza



STRATUS 36
URBAN CRAFT (a) (f)
30x30 P19 /peça_pieza



STRATUS 36
URBAN ANTRACITE (a) (f) ◆ NEW
30x30 P19 /peça_pieza

Antislip: Produtos que minimizam o risco de deslizamento.
Antislip: Products that minimize the risk of slipping.
Antislip: Produits qui réduisent le risque de glissement.
Antislip: Productos que minimizan el riesgo de deslizamiento.

Hydraulik



Urban

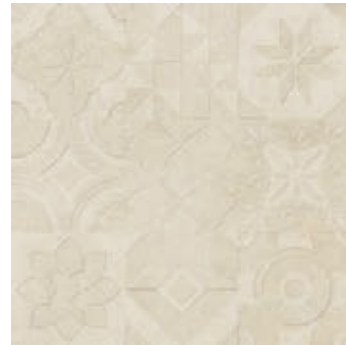

HYDRAULIK OFFWHITE

45x45	NAT	[...x0,85 cm]	P73	V3	4	class 1	A	R9
	RECT	[44,4x44,4x0,85 cm]	P83	V3	4	class 1	A	R9



HYDRAULIK BONE

45x45	NAT	[...x0,85 cm]	P73	V3	4	class 1	A	R9
	RECT	[44,4x44,4x0,85 cm]	P83	V3	4	class 1	A	R9



HYDRAULIK FOG

45x45	NAT	[...x0,85 cm]	P73	V3	4	class 1	A	R9
	RECT	[44,4x44,4x0,85 cm]	P83	V3	4	class 1	A	R9



HYDRAULIK CRAFT

45x45	NAT	[...x0,85 cm]	P73	V3	4	class 1	A	R9
	RECT	[44,4x44,4x0,85 cm]	P83	V3	4	class 1	A	R9

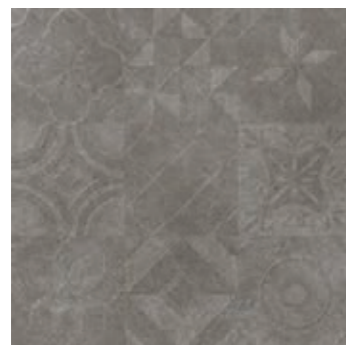

HYDRAULIK GRIS

45x45	NAT	[...x0,85 cm]	P73	V3	4	class 1	A	R9
	RECT	[44,4x44,4x0,85 cm]	P83	V3	4	class 1	A	R9



HYDRAULIK ANTRACITE **NEW**

45x45	NAT	[...x0,85 cm]	P73	V3	4	class 1	A	R9
	RECT	[44,4x44,4x0,85 cm]	P83	V3	4	class 1	A	R9



Hydraulik Craft

Existem várias peças diferentes, de acordo com o desenho do decorado, que devem ser aplicadas alternadamente, de modo a obter-se uma solução mais rica e variada.
 There are different pieces, matching the design of the decorated tiles, which should be applied alternately in order to obtain a richer and more varied decoration.
 Différentes pièces correspondent au dessin du décor. Il convient de les appliquer de façon alternée pour obtenir une disposition plus riche et plus variée.
 Existen diversas piezas diferentes, de acuerdo con el diseño del decorado, que deben aplicarse de forma alterna, con el fin de obtener una solución más y variada.

PEÇA_PIECE		PEÇA_PIECE		PEÇA_PIECE		PEÇA_PIECE			
DG	Nat	Rect	RB	Nat	Rect	DG CF	Rect	DG CF CANTO	Rect
30x30 cm	P08	P10	9,5x30 cm	P07	P08	30x60 cm	P157	30x60 cm	P207
30x60 cm	P12	P18	8x45 cm	P07	P08				
60x60 cm	-	P36	8x60 cm	P10	P12				
45x45 cm	P12	P18	8x90 cm	-	P28				
30x120 cm	-	P97	8x120 cm	-	P28				
45x90 cm	-	P97							
60x120 cm	-	P167							

DG CF / DG CF Canto: Peças produzidas sob encomenda.
 DG CF / DG CF Canto: Pieces produced on order.
 DG CF / DG CF Canto: Pièces produites sur commande
 DG CF / DG CF Canto: Piezas producidas por encargo

DG CF Canto: Disponível em canto esquerdo e direito.
 DG CF Canto: Available in left and right corner.
 DG CF Canto: Disponible en angle gauche et droit.
 DG CF Canto: Canto izquierdo y derecho disponibles.



Marbles

Página
Page
Page
Página

Baltic Grey	220
Statuario White	224
Absolut Black	228
Emperador Brown	232
Venezia Bianco	236
Bianco	240
Pulpis	244
Tuscania	250
Onix	254
Moka	258

Estilo Intemporal

O mármore é um material intemporal e conjuga-se na perfeição com tons escuros para criar um ar mais industrial, ou com dourado para um look mais glamoroso.

Timeless Look

Marble is a timeless material and goes perfectly with dark shades for a more industrial look, or gold for a more glamorous look.

Style Intemporel

Le marbre est un matériau intemporel et se marie à la perfection avec les tonalités foncées pour créer une atmosphère plus industrielle ou avec le doré pour un look plus glamour.

Estilo Atemporal

El mármol es un material atemporal que combina perfectamente con tonos oscuros, para crear un aire más industrial, o con dorado, para un aspecto más glamoroso.



O efeito enredado dos veios do mármore natural permite criar espaços nobres e intensos, com uma elegância informal.
 The mesh effect of natural marble veins helps create noble and intense space with informal elegance.
 L'effet emmêlé des veines du marbre naturel permet de créer des espaces nobles et intenses, avec une élégance informelle.
 El efecto enredado de las vetas del mármol natural permite crear espacios nobles e intensos, con una elegancia informal.



Baltic Grey



Baltic Grey
 Absolut Black
 Pyramid Black & Grey



Baltic Grey
 Pyramid Grey

Baltic Grey

01 cor
color
couleur
color

04 formatos
formats
formats
formatos

02 acabamentos
finishes
finitions
acabados

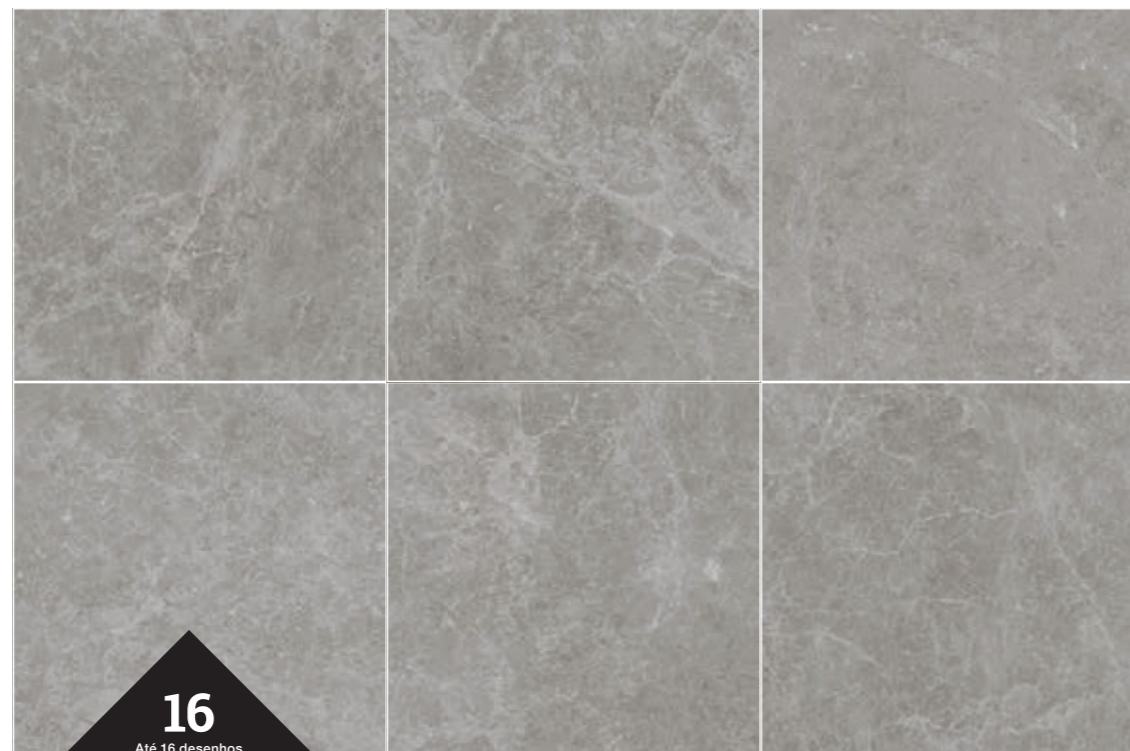

16
Até 16 desenhos
Up to 16 designs
Jusqu'à 16 dessins
Hasta 16 diseños

GRAPHIC VARIATION

Baltic Grey

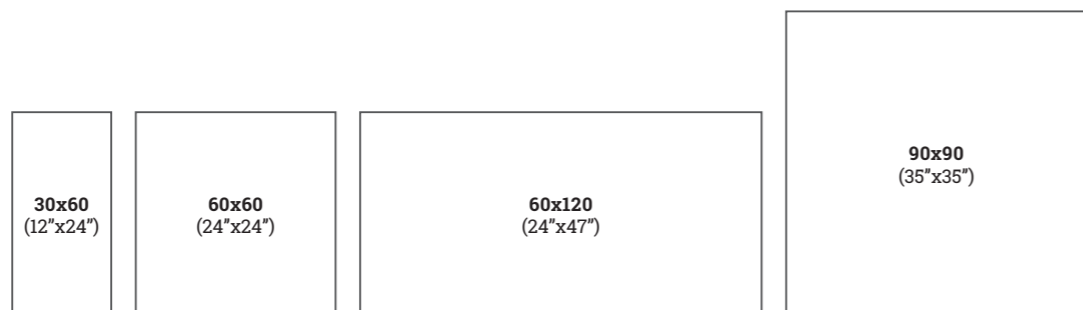

Peças_Pieces		Caixa_Box			Europaleta_Europallet			
	Espeçura (mm) Thickness (mm)	Nº Peças No Pieces	M² Aprox. No of Sq. M. Approx.	Peso (Kg) Weight Kg	Nº Caixas No Boxes	M² Aprox. No of Sq. M. Approx.	Peso (Kg) Weight (Kg)	
30x60 cm	Matt Rect.	± 9,8 ± 5%	5	0.90	20.7	48	43.20	1 015
	Pol.	± 9,8 ± 5%	5	0.90	20.7	48	43.20	1 015
60x60 cm	Matt Rect.	± 9,8 ± 5%	4	1.44	33.0	32	46.08	1 077
	Pol.	± 9,8 ± 5%	4	1.44	33.0	32	46.08	1 077
60x120 cm	Matt Rect.	± 9,8 ± 5%	2	1.44	33.0	27	38.88	912
	Pol.	± 9,8 ± 5%	2	1.44	33.0	27	38.88	912
90x90 cm	Matt Rect.	± 10,5 ± 0.5mm	2	1.62	38.0	24	38.88	967
	Pol.	± 10,5 ± 0.5mm	2	1.62	38.0	24	38.88	967

De modo a proteger a superfície das peças, os produtos no acabamento polido têm uma fina camada de impermeabilizante, que apenas deve ser removida após a conclusão da obra.
Tiles with polished finish are protected with waterproof coating that must be removed only after the works are concluded.
En vue de protéger la surface des pièces, les produits à la finition polie ont une fine couche d'imperméabilisant qui ne devrait être enlevée qu'après l'achèvement des travaux.
Con el fin de proteger la superficie de las piezas, los productos con acabado pulido tienen una fina capa de impermeabilizante, que solo debe eliminarse una vez terminado el trabajo.

Baltic Grey



BALTIC GREY

60x120	MATT RECT	[59,2x118,4x0,98 cm]	P109	V3	A4	class 1	≥0,42
	POL	[59,2x118,4x0,98 cm]	P129	V3	A3	—	—
30x60	MATT RECT	[29,6x59,2x0,98 cm]	P91	V3	A4	class 1	≥0,42
	POL	[29,6x59,2x0,98 cm]	P105	V3	A3	—	—



BALTIC GREY

90x90	MATT RECT	[89,0x89,0x1,05 cm]	P117	V3	A4	class 1	≥0,42
	POL	[89,0x89,0x1,05 cm]	P131	V3	A3	—	—
60x60	MATT RECT	[59,2x59,2x0,98 cm]	P91	V3	A4	class 1	≥0,42
	POL	[59,2x59,2x0,98 cm]	P105	V3	A3	—	—



TARSUS (a) (b) (d) (f)

29x29 P36 /peça_piece

Base: Baltic grey
Statuario white

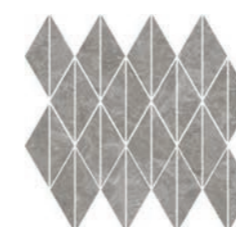

PYRAMID GREY (a) (b) (d) (f)

28x30 P26 /peça_piece

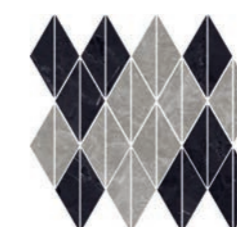

PYRAMID BLACK & GREY (a) (b) (d) (f)

28x30 P28 /peça_piece

Base: Absolut black
Baltic grey



BYZANTINE (a) (b) (d) (f)

30x52 P32 /peça_piece

Base: Absolut black
Baltic grey
Statuario white

DG	Matt Rect	Pol	RB	Matt Rect	Pol	DG CF	Matt Rect	Pol	DG CF CANTO	Matt Rect	Pol
30x60 cm	P18	P18	9,5x30 cm	P08	P08	30x60 cm	P157	P157	30x60 cm	P207	P207
60x60 cm	P36	P36	8x60 cm	P12	P12						
45x90 cm	P97	P97	8x90 cm	P28	P28						
30x120 cm	P97	P97	8x120 cm	P28	P28						
60x120 cm	P167	P167									

Tendo em vista alcançar um efeito global mais real e harmonioso, são produzidas peças diferentes umas das outras com variações de desenho e/ou cores entre elas.
For a more genuine and harmonious effect overall, different tiles with design and/or colour variations are produced.
Afin d'obtenir un effet global plus réel et harmonieux, nos pièces sont différentes les unes des autres avec des variations de dessin et / ou de nuances entre elles.
Para lograr un efecto global más real y armonioso, se producen piezas diferentes unas de otras con variaciones de diseño y/o color.

DG CF / DG CF Canto: Peças produzidas sob encomenda.
DG CF / DG CF Canto: Pieces produced on order.
DG CF / DG CF Canto: Pièces produites sur commande
DG CF / DG CF Canto: Piezas producidas por encargo

DG CF Canto: Disponível em canto esquerdo e direito.
DG CF Canto: Available in left and right corner.
DG CF Canto: Disponible en angle gauche et droit.
DG CF Canto: Canto izquierdo y derecho disponibles.

A pureza da matéria refletida na cerâmica para ambientes exclusivos.
The purity of the material reflected in ceramics for exclusive environments.
La pureté de la matière reflétée dans la céramique pour des ambiances exclusives.
La pureza de la materia reflejada en la cerámica para ambientes exclusivos.

Statuario White



Statuario White
Absolut Black
Modulus Absolut



Statuario White
Modulus Statuario White
Absolut Black

Statuario White

01 cor
color
couleur
color

04 formatos
formats
formats
formats

02 acabamentos
finishes
finitions
acabados



13
Até 13 desenhos
Up to 13 designs
Jusqu'à 13 dessins
Hasta 13 diseños

Statuario White

GRAPHIC VARIATION

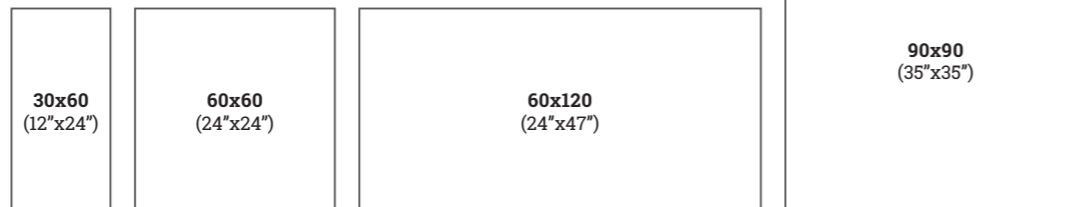

	Peças / Pieces	Caixa / Box			Europaleta / Europallet			
		Espessura (mm) / Thickness (mm)	Nº Peças / No Pieces	M² Aprox. / No of Sq. M. Approx.	Peso (Kg) / Weight Kg	Nº Caixas / No Boxes	M² Aprox. / No of Sq. M. Approx.	Peso (Kg) / Weight (Kg)
30x60 cm	Matt Rect.	± 9,8 ± 5%	5	0,90	20,7	48	43,20	1 015
	Pol.	± 9,8 ± 5%	5	0,90	20,7	48	43,20	1 015
60x60 cm	Matt Rect.	± 9,8 ± 5%	4	1,44	33,0	32	46,08	1 077
	Pol.	± 9,8 ± 5%	4	1,44	33,0	32	46,08	1 077
60x120 cm	Matt Rect.	± 9,8 ± 5%	2	1,44	33,0	27	38,88	912
	Pol.	± 9,8 ± 5%	2	1,44	33,0	27	38,88	912
90x90 cm	Matt Rect.	± 10,5 ± 0,5mm	2	1,62	38,0	24	38,88	967
	Pol.	± 10,5 ± 0,5mm	2	1,62	38,0	24	38,88	967

De modo a proteger a superfície das peças, os produtos no acabamento polido têm uma fina camada de impermeabilizante, que apenas deve ser removida após a conclusão da obra.
Tiles with polished finish are protected with waterproof coating that must be removed only after the works are concluded.
En vue de protéger la surface des pièces, les produits à la finition polie ont une fine couche d'imperméabilisant qui ne devrait être enlevée qu'après l'achèvement des travaux.
Con el fin de proteger la superficie de las piezas, los productos con acabado pulido tienen una fina capa de impermeabilizante, que solo debe eliminarse una vez terminado el trabajo.

Statuario White



STATUARIO WHITE

60x120	MATT RECT	[59,2x118,4x0,98 cm]	P109	V3	A4	class 1	≥0,42
	POL	[59,2x118,4x0,98 cm]	P129	V3	A3	—	—
30x60	MATT RECT	[29,6x59,2x0,98 cm]	P91	V3	A4	class 1	≥0,42
	POL	[29,6x59,2x0,98 cm]	P105	V3	A3	—	—



STATUARIO WHITE

90x90	MATT RECT	[89,0x89,0x1,05 cm]	P117	V3	A4	class 1	≥0,42
	POL	[89,0x89,0x1,05 cm]	P131	V3	A3	—	—
60x60	MATT RECT	[59,2x59,2x0,98 cm]	P91	V3	A4	class 1	≥0,42
	POL	[59,2x59,2x0,98 cm]	P105	V3	A3	—	—



MODULUS STATUARIO (a) (d) (f)
33x37 P32 /peça_pieza



PEAK ABSOLUT(a) (d) (f)
30x30 P32 /peça_pieza
Base: Absolut Black Statuario White



HEXA STATUARIO (a) (d) (f)
24x30 P32 /peça_pieza
Base: Absolut Black Statuario White

DG	PEÇA / PIECE		PEÇA / PIECE		PEÇA / PIECE		PEÇA / PIECE	
	Matt Rect	Pol	RB	Matt Rect	Pol	DG CF	Matt Rect	Pol
30x60 cm	P18	P18	9,5x30 cm	P08	P08	30x60 cm	P157	P157
60x60 cm	P36	P36	8x60 cm	P12	P12	30x60 cm	P207	P207
45x90 cm	P97	P97	8x90 cm	P28	P28			
30x120 cm	P97	P97	8x120 cm	P28	P28			
60x120 cm	P167	P167						

DG CF / DG CF Canto: Peças produzidas sob encomenda.
DG CF / DG CF Canto: Pieces produced on order.
DG CF / DG CF Canto: Pièces produites sur commande
DG CF / DG CF Canto: Piezas producidas por encargo
DG CF Canto: Disponível em canto esquerdo e direito.
DG CF Canto: Available in left and right corner.
DG CF Canto: Disponible en angle gauche et droit.
DG CF Canto: Canto izquierdo y derecho disponibles.

Tendo em vista alcançar um efeito global mais real e harmonioso, são produzidas peças diferentes umas das outras com variações de desenho e/ou cores entre elas.
For a more genuine and harmonious effect overall, different tiles with design and/or colour variations are produced.
Afin d'obtenir un effet global plus réel et harmonieux, nos pièces sont différentes les unes des autres avec des variations de dessin et / ou de nuances entre elles.
Para lograr un efecto global más real y armonioso, se producen piezas diferentes unas de otras con variaciones de diseño y/o color.

A profundidade do negro em harmonia com os delicados veios brancos promovem uma elegância única.
Deep black in harmony with the delicate white veins favour a unique elegance.
La profondeur du noir et les délicates veines blanches font ressortir une élégance unique.
La profundidad del negro y las delicadas vetas blancas contribuyen para una elegancia única.

Absolut Black



Absolut Black
Peak Absolüt



Absolut Black
Hexa Statuario

Absolut Black

- 01** cor
color
couleur
color
- 04** formatos
formats
formats
formats
- 02** acabamentos
finishes
finitions
acabados

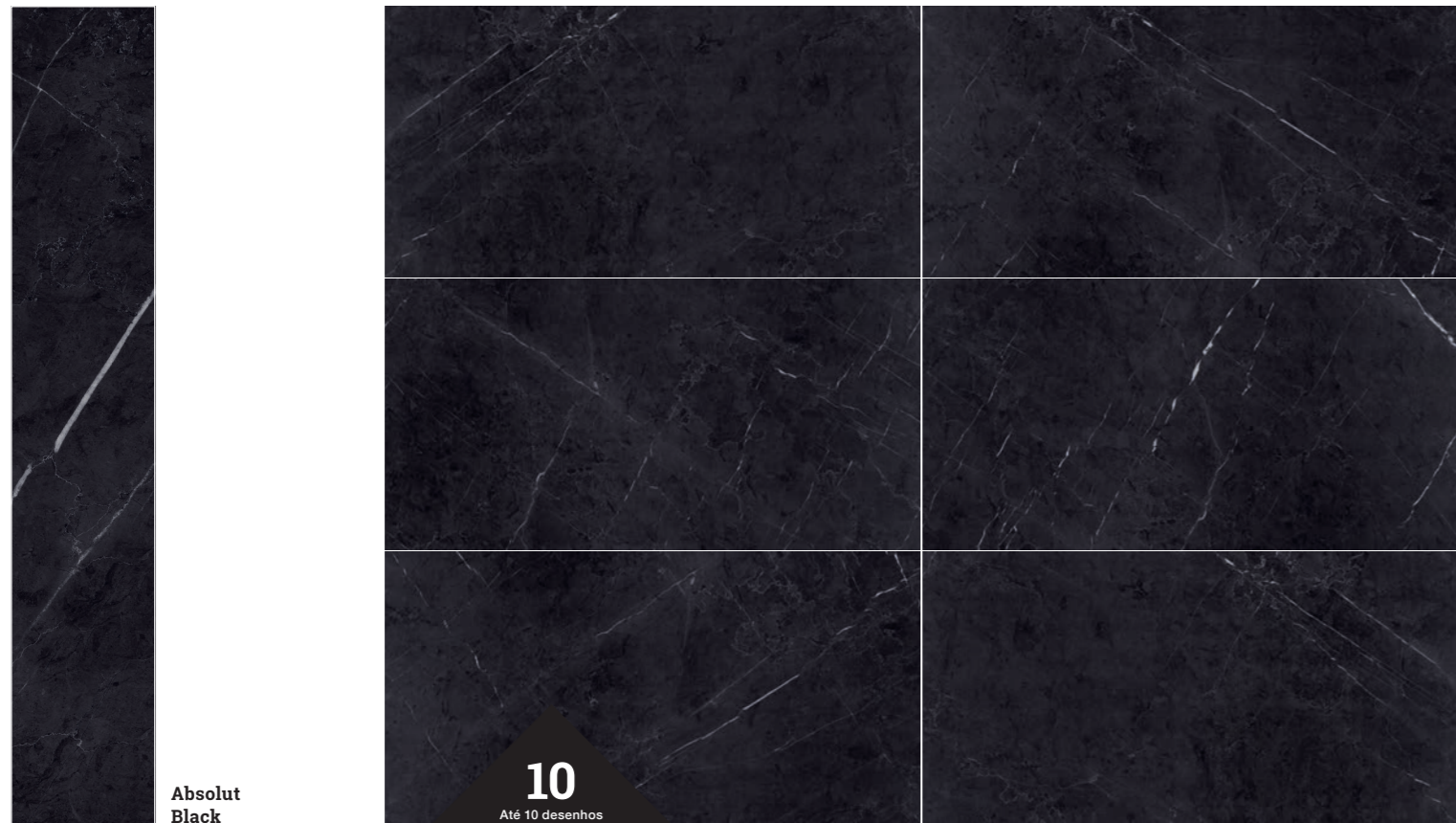

10
Até 10 desenhos
Up to 10 designs
Jusqu'à 10 dessins
Hasta 10 diseños

GRAPHIC VARIATION

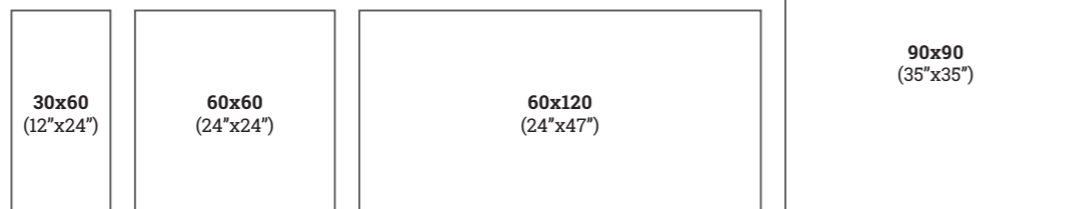

Peças - Pieces		Caixa - Box			Europaleta - Europallet			
	Espeçura (mm) Thickness (mm)	Nº Peças No. of Pieces	M² Aprox. No of Sq. M. Approx.	Peso (Kg) Weight Kg	Nº Caixas No Boxes	M² Aprox. No of Sq. M. Approx.	Peso (Kg) Weight (Kg)	
30x60 cm	Matt Rect.	± 9,8 ± 5%	5	0.90	20.7	48	43.20	1 015
	Pol.	± 9,8 ± 5%	5	0.90	20.7	48	43.20	1 015
60x60 cm	Matt Rect.	± 9,8 ± 5%	4	1.44	33.0	32	46.08	1 077
	Pol.	± 9,8 ± 5%	4	1.44	33.0	32	46.08	1 077
60x120 cm	Matt Rect.	± 9,8 ± 5%	2	1.44	33.0	27	38.88	912
	Pol.	± 9,8 ± 5%	2	1.44	33.0	27	38.88	912
90x90 cm	Matt Rect.	± 10,5 ± 0.5mm	2	1.62	38.0	24	38.88	967
	Pol.	± 10,5 ± 0.5mm	2	1.62	38.0	24	38.88	967

De modo a proteger a superfície das peças, os produtos no acabamento polido têm uma fina camada de impermeabilizante, que apenas deve ser removida após a conclusão da obra.
Tiles with polished finish are protected with waterproof coating that must be removed only after the works are concluded.
En vue de protéger la surface des pièces, les produits à la finition polie ont une fine couche d'imperméabilisant qui ne devrait être enlevée qu'après l'achèvement des travaux.
Con el fin de proteger la superficie de las piezas, los productos con acabado pulido tienen una fina capa de impermeabilizante, que solo debe eliminarse una vez terminado el trabajo.

Absolut Black



ABSOLUT BLACK

60x120	MATT RECT	[59,2x118,4x0,98 cm]	P109	V3	3	class 1	≥0,42
	POL	[59,2x118,4x0,98 cm]	P129	V3	2	—	—
30x60	MATT RECT	[29,6x59,2x0,98 cm]	P91	V3	3	class 1	≥0,42
	POL	[29,6x59,2x0,98 cm]	P105	V3	2	—	—



ABSOLUT BLACK

90x90	MATT RECT	[89,0x89,0x1,05 cm]	P117	V3	3	class 1	≥0,42
	POL	[89,0x89,0x1,05 cm]	P131	V3	2	—	—
60x60	MATT RECT	[59,2x59,2x0,98 cm]	P91	V3	3	class 1	≥0,42
	POL	[59,2x59,2x0,98 cm]	P105	V3	2	—	—



MODULUS ABSOLUT (a) (d) (f)
33x37 P32 /peça_pieza



PEAK ABSOLUT (a) (d) (f)
30x30 P32 /peça_pieza
Base: Absolut Black Statuario White



HEXA STATUARIO (a) (d) (f)
24x30 P32 /peça_pieza
Base: Absolut Black Statuario White

DG	PEÇA _ PIECE		PEÇA _ PIECE		PEÇA _ PIECE		PEÇA _ PIECE	
	Matt Rect	Pol	RB	Matt Rect	Pol	DG CF	Matt Rect	Pol
30x60 cm	P18	P18	9,5x30 cm	P08	P08	30x60 cm	P157	P157
60x60 cm	P36	P36	8x60 cm	P12	P12	30x60 cm	P207	P207
45x90 cm	P97	P97	8x90 cm	P28	P28			
30x120 cm	P97	P97	8x120 cm	P28	P28			
60x120 cm	P167	P167						

DG CF / DG CF Canto: Peças produzidas sob encomenda.
DG CF / DG CF Canto: Pieces produced on order.
DG CF / DG CF Canto: Pièces produites sur commande
DG CF / DG CF Canto: Piezas producidas por encargo

DG CF Canto: Disponível em canto esquerdo e direito.
DG CF Canto: Available in left and right corner.
DG CF Canto: Disponible en angle gauche et droit.
DG CF Canto: Canto izquierdo y derecho disponibles.

Tendo em vista alcançar um efeito global mais real e harmonioso, são produzidas peças diferentes umas das outras com variações de desenho e/ou cores entre elas.
For a more genuine and harmonious effect overall, different tiles with design and/or colour variations are produced.
Afin d'obtenir un effet global plus réel et harmonieux, nos pièces sont différentes les unes des autres avec des variations de dessin et / ou de nuances entre elles.
Para lograr un efecto global más real y armonioso, se producen piezas diferentes unas de otras con variaciones de diseño y/o color.

O efeito da pedra natural enriquecida com cor para preencher os espaços com emoções fortes.
The effect of natural stone enriched with colour to complete space with strong emotions.
L'effet de la pierre naturelle enrichie de couleur pour remplir les espaces d'émotions fortes.
El efecto de la piedra natural enriquecida con color para llenar los espacios con emociones fuertes.

Emperador Brown



Emperador Brown
Scarpa Emperador



Emperador Brown
Statuario White
Jinko Nude

Emperador Brown

- 01** cor color couleur color
- 04** formatos formats formats formatos
- 02** acabamentos finishes finitions acabados

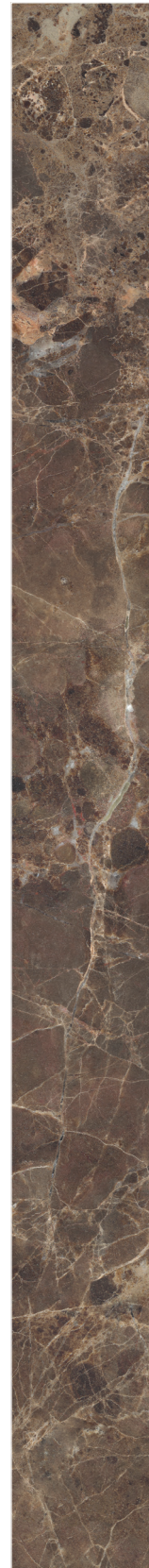

Emperador Brown

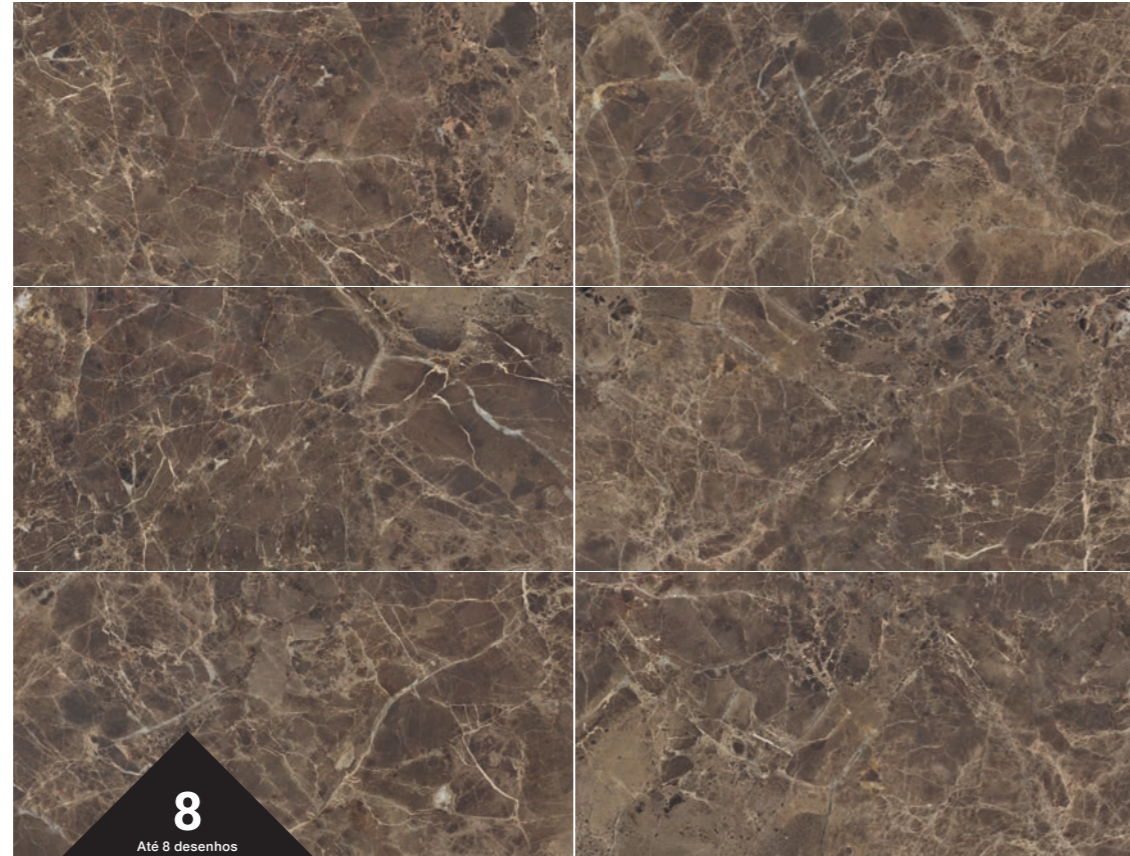

8
Até 8 desenhos
Up to 8 designs
Jusqu'à 8 dessins
Hasta 8 diseños

GRAPHIC VARIATION

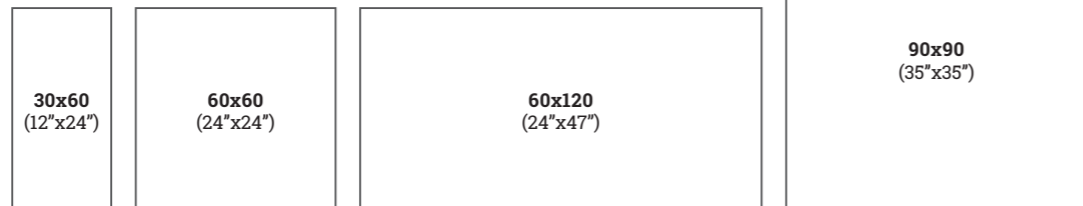

Peças - Pieces		Caixa - Box			Europaleta - Europallet			
		Espessura (mm) Thickness (mm)	Nº Peças No Pieces	M² Aprox. No of Sq. M. Approx.	Peso (Kg) Weight Kg	Nº Caixas No Boxes	M² Aprox. No of Sq. M. Approx.	Peso (Kg) Weight (Kg)
30x60 cm	Matt Rect.	± 9,8 ± 5%	5	0.90	20.7	48	43.20	1 015
	Pol.	± 9,8 ± 5%	5	0.90	20.7	48	43.20	1 015
60x60 cm	Matt Rect.	± 9,8 ± 5%	4	1.44	33.0	32	46.08	1 077
	Pol.	± 9,8 ± 5%	4	1.44	33.0	32	46.08	1 077
60x120 cm	Matt Rect.	± 9,8 ± 5%	2	1.44	33.0	27	38.88	912
	Pol.	± 9,8 ± 5%	2	1.44	33.0	27	38.88	912
90x90 cm	Matt Rect.	± 10,5 ± 0.5mm	2	1.62	38.0	24	38.88	967
	Pol.	± 10,5 ± 0.5mm	2	1.62	38.0	24	38.88	967

De modo a proteger a superfície das peças, os produtos no acabamento polido têm uma fina camada de impermeabilizante, que apenas deve ser removida após a conclusão da obra.
Tiles with polished finish are protected with waterproof coating that must be removed only after the works are concluded.
En vue de protéger la surface des pièces, les produits à la finition polie ont une fine couche d'imperméabilisant qui ne devrait être enlevée qu'après l'achèvement des travaux.
Con el fin de proteger la superficie de las piezas, los productos con acabado pulido tienen una fina capa de impermeabilizante, que solo debe eliminarse una vez terminado el trabajo.

Emperador Brown

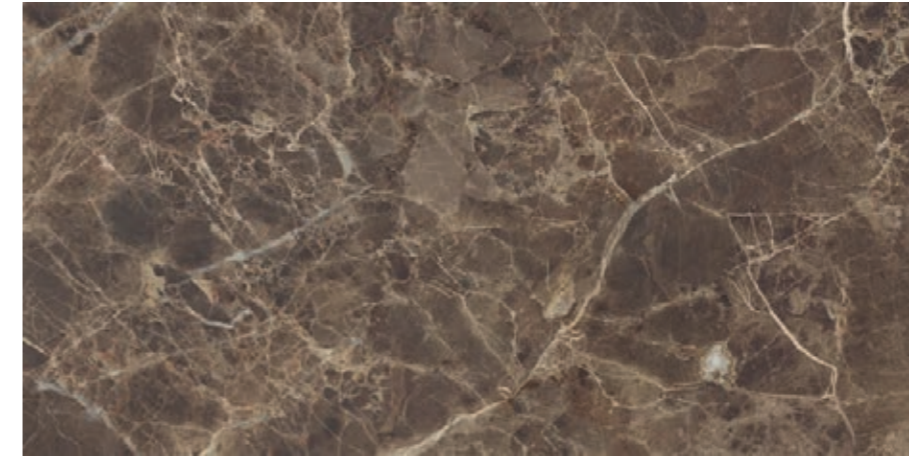

EMPERADOR BROWN

60x120	MATT RECT	[59,2x118,4x0,98 cm]	P109	V3	3	class 1	≥0,42
	POL	[59,2x118,4x0,98 cm]	P129	V3	2	—	—
30x60	MATT RECT	[29,6x59,2x0,98 cm]	P91	V3	3	class 1	≥0,42
	POL	[29,6x59,2x0,98 cm]	P105	V3	2	—	—

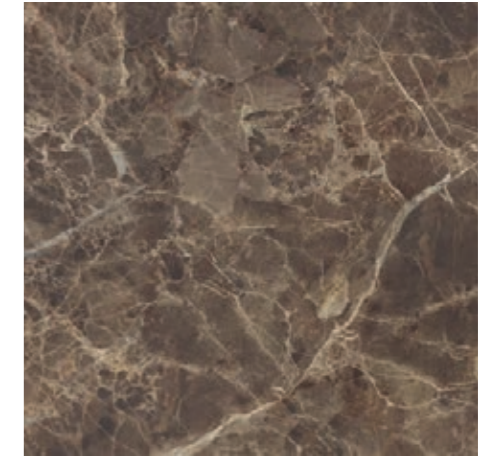

EMPERADOR BROWN

90x90	MATT RECT	[89,0x89,0x1,05 cm]	P117	V3	3	class 1	≥0,42
	POL	[89,0x89,0x1,05 cm]	P131	V3	2	—	—
60x60	MATT RECT	[59,2x59,2x0,98 cm]	P91	V3	3	class 1	≥0,42
	POL	[59,2x59,2x0,98 cm]	P105	V3	2	—	—



SCARPA EMPERADOR (a) (d) (f)

30x33	P32 / peça .piece
-------	-------------------

Base: Emperador Brown
Pulpis Bege

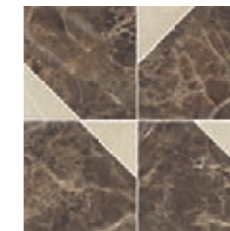

NEXUS (a) (f)

30x30	POL	P32 / peça .piece
-------	-----	-------------------

Base: Emperador Brown
Pulpis Bege

	PEÇA _PIECE		PEÇA _PIECE		PEÇA _PIECE		PEÇA _PIECE				
DG	Matt Rect	Pol	RB	Matt Rect	Pol	DG CF	Matt Rect	Pol	DG CF CANTO	Matt Rect	Pol
30x60 cm	P18	P18	9,5x30 cm	P08	P08	30x60 cm	P157	P157	30x60 cm	P207	P207
60x60 cm	P36	P36	8x60 cm	P12	P12						
45x90 cm	P97	P97	8x90 cm	P28	P28						
30x120 cm	P97	P97	8x120 cm	P28	P28						
60x120 cm	P167	P167									

DG CF / DG CF Canto: Peças produzidas sob encomenda.
DG CF / DG CF Canto: Pieces produced on order.
DG CF / DG CF Canto: Pièces produites sur commande
DG CF / DG CF Canto: Piezas producidas por encargo
DG CF Canto: Disponível em canto esquerdo e direito.
DG CF Canto: Available in left and right corner.
DG CF Canto: Disponible en angle gauche et droit.
DG CF Canto: Canto izquierdo y derecho disponibles.

Tendo em vista alcançar um efeito global mais real e harmonioso, são produzidas peças diferentes umas das outras com variações de desenho e/ou cores entre elas.
For a more genuine and harmonious effect overall, different tiles with design and/or colour variations are produced.
Afin d'obtenir un effet global plus réel et harmonieux, nos pièces sont différentes les unes des autres avec des variations de dessin et / ou de nuances entre elles.
Para lograr un efecto global más real y armonioso, se producen piezas diferentes unas de otras con variaciones de diseño y/o color.

Veios cinza, em fundo branco cristalino, que dão profundidade aos espaços.
Strokes of grey against a pristine white background, which lend depth to space.
Veines grises, sur fond blanc cristallin, qui confèrent de la profondeur aux espaces.
Vetas grises sobre fondo blanco cristalino, que dan profundidad a los espacios.

Venezia Bianco



Trio Venezia Bianco
Venezia Bianco



Venezia Bianco

Venezia Bianco

- 01** cor color couleur color
- 03** formatos formats formats formatos
- 02** acabamentos finishes finitions acabados



Venezia Bianco

14
Até 14 desenhos
Up to 14 designs
Jusqu'à 14 dessins
Hasta 14 diseños

GRAPHIC VARIATION



Peças / Pieces		Caixa / Box			Europalette / Europallet			
		Espessura (mm) Thickness (mm)	Nº Peças No of Pieces	M² Aprox. No of Sq. M. Approx.	Peso (Kg) Weight (Kg)	Nº Caixas No Boxes	M² Aprox. No of Sq. M. Approx.	Peso (Kg) Weight (Kg)
30x60 cm	Rect.	± 8,5 ± 5 %	5	0.90	19.0	60	54.00	1 161
	Pol.	± 8,0 ± 5 %	5	0.90	17.0	60	54.00	1 041
60x60 cm	Rect.	± 8,5 ± 5 %	4	1.44	28.7	36	51.84	1 054
	Pol.	± 8,0 ± 5 %	4	1.44	26.7	36	51.84	982
60x120 cm	Rect.	± 9,8 ± 5 %	2	1.44	33.0	30	43.20	1 011
	Pol.	± 9,3 ± 5 %	2	1.44	31.0	30	43.20	951

De modo a proteger a superfície das peças, os produtos no acabamento polido têm uma fina camada de impermeabilizante, que apenas deve ser removida após a conclusão da obra.
Tiles with polished finish are protected with waterproof coating that must be removed only after the works are concluded.
En vue de protéger la surface des pièces, les produits à la finition polie ont une fine couche d'imperméabilisant qui ne devrait être enlevée qu'après l'achèvement des travaux.
Con el fin de proteger la superficie de las piezas, los productos con acabado pulido tienen una fina capa de impermeabilizante, que solo debe eliminarse una vez terminado el trabajo.

Venezia Bianco

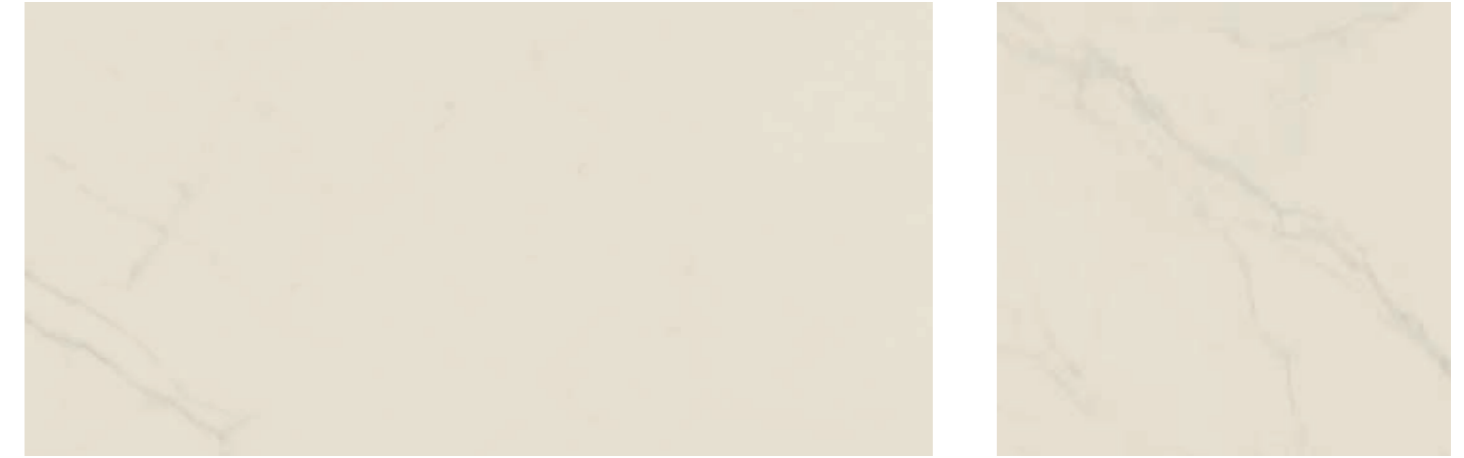

VENEZIA BIANCO

60x120	MATT RECT	[59,2x118,4x0,98 cm]	P109	V3	4	class 1	≥0,42
	POL	[59,2x118,4x0,98 cm]	P129	V3	3	—	—
30x60	MATT RECT	[29,6x59,2x0,85 cm]	P91	V3	4	class 1	≥0,42
	POL	[29,6x59,2x0,80 cm]	P105	V3	3	—	—

VENEZIA BIANCO

60x60	MATT RECT	[59,2x59,2x0,85 cm]	P91	V3	4	class 1	≥0,42
	POL	[59,2x59,2x0,80 cm]	P105	V3	3	—	—

DIVERSAS FORMAS DE APLICAÇÃO: · DIFFERENT WAYS OF APPLICATION: · DIFFÉRENTS MODES D'APPLICATION: · DIVERSAS FORMAS DE APLICACIÓN:



TRIO VENEZIA BIANCO (a) (d) (f)
20x22 P22 /peça_piece
Base: Venezia Bianco Cromática Preto

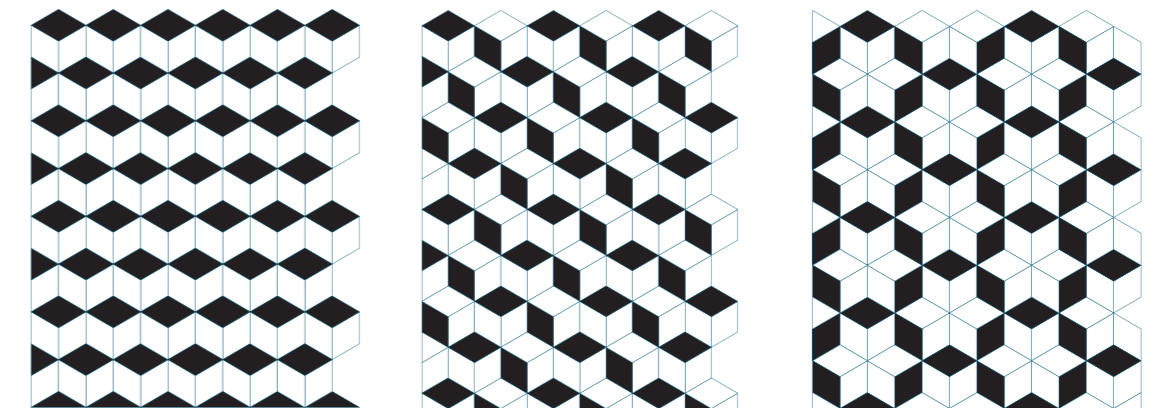

DG	PEÇA_PIECE		PEÇA_PIECE		PEÇA_PIECE		PEÇA_PIECE				
	Rect	Pol	Rect	Pol	Rect	Pol	Rect	Pol			
30x60 cm	P18	P18	9,5x30 cm	P08	P08	30x60 cm	P157	P157	30x60 cm	P207	P207
60x60 cm	P36	P36	8x60 cm	P12	P12						
30x120 cm	P97	P97	8x120 cm	P28	P28						
60x120 cm	P167	P167									

Tendo em vista alcançar um efeito global mais real e harmonioso, são produzidas peças diferentes umas das outras com variações de desenho e/ou cores entre elas.
For a more genuine and harmonious effect overall, different tiles with design and/or colour variations are produced.
Afin d'obtenir un effet global plus réel et harmonieux, nos pièces sont différentes les unes des autres avec des variations de dessin et / ou de nuances entre elles.
Para lograr un efecto global más real y armonioso, se producen piezas diferentes unas de otras con variaciones de diseño y/o color.

DG CF / DG CF Canto: Peças produzidas sob encomenda.
DG CF / DG CF Canto: Pieces produced on order.
DG CF / DG CF Canto: Pièces produites sur commande
DG CF / DG CF Canto: Piezas producidas por encargo

DG CF Canto: Disponível em canto esquerdo e direito.
DG CF Canto: Available in left and right corner.
DG CF Canto: Disponible en angle gauche et droit.
DG CF Canto: Canto izquierdo y derecho disponibles.

O brilho do mármore com um raiado suave, em ouro e prata.
The shine of marble with soft rays of gold and silver.
L'éclat du marbre avec de légères rayures, en or et en argent.
El brillo del mármol con un veteado en oro y plata.

Bianco



Bianco Oro
Flint Arg Prata



Bianco Sivec
Vichy Sivec
Globe Antracite

Bianco

02 cores
couleurs
colors

02 formatos
formats
formats

01 acabamento
finish
finition
acabado



Sivec

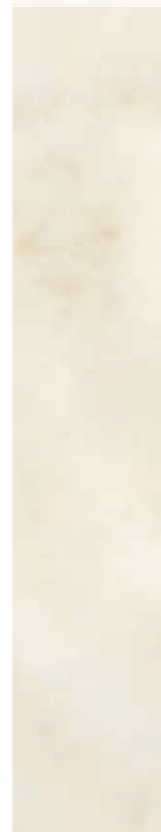

Oro



9
Até 9 desenhos
Up to 9 designs
Jusqu'à 9 dessins
Hasta 9 diseños

GRAPHIC VARIATION

30x60
(12"x24")

30x90
(12"x35")

Peças - Pieces		Espessura (mm) Thickness (mm)	Caixa - Box		Peso (Kg) Weight (Kg)	Europaleta - Europallet		Peso (Kg) Weight (Kg)
30x60 cm	Rect.		Nº Peças No Pieces	M² Aprox. No of Sq. M. Approx.		Nº Caixas No Boxes	M² Aprox. No of Sq. M. Approx.	
30x60 cm	Rect.	± 9,0 ± 5 %	5	0.90	14.5	72	64.8	1 065
30x90 cm	Rect.	± 12,3 ± 0,5 mm	4	1.08	22.0	40	43.2	901

Bianco

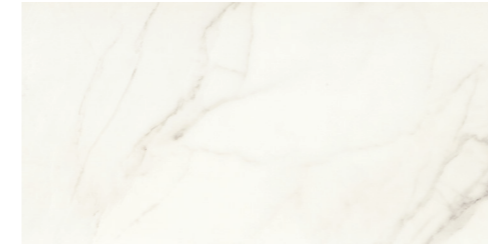

BIANCO SIVEC

30x60	RECT	[29,6x59,2x0,90 cm]	P75
30x90	RECT	[29,6x88,8x1,23 cm]	P92

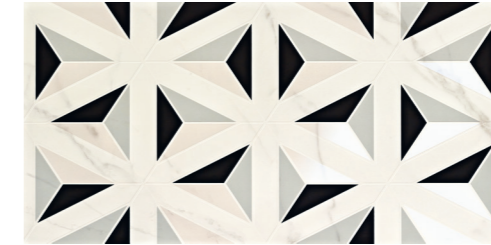

VICHY SIVEC

30x60	RECT	[29,6x59,2x0,90 cm]	P38 / peça_piece
-------	------	-----------------------	------------------

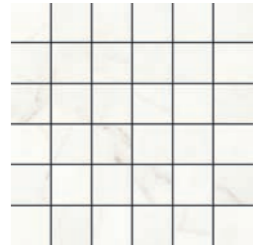

STRATUS 36 BIANCO SIVEC (a)

30x30	P17 / peça_piece
-------	------------------

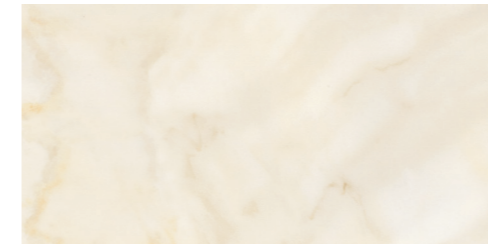

BIANCO ORO

30x60	RECT	[29,6x59,2x0,90 cm]	P75
30x90	RECT	[29,6x88,8x1,23 cm]	P92



VICHY ORO

30x60	RECT	[29,6x59,2x0,90 cm]	P38 / peça_piece
-------	------	-----------------------	------------------

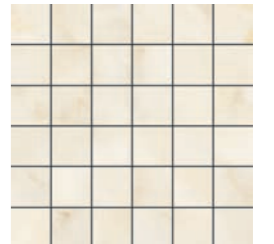

STRATUS 36 BIANCO ORO (a)

30x30	P17 / peça_piece
-------	------------------



Tendo em vista alcançar um efeito global mais real e harmonioso, são produzidas peças diferentes umas das outras com variações de desenho e/ou cores entre elas.
For a more genuine and harmonious effect overall, different tiles with design and/or colour variations are produced.
Afin d'obtenir un effet global plus réel et harmonieux, nos pièces sont différentes les unes des autres avec des variations de dessin et / ou de nuances entre elles.
Para lograr un efecto global más real y armonioso, se producen piezas diferentes unas de otras con variaciones de diseño y/o color.

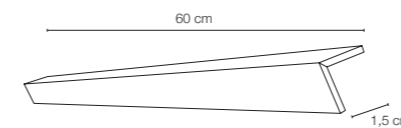

PERFIL BIANCO

1,5x60	RECT	[1,5x59,2x0,90 cm]	P32 /peça_piece
--------	------	----------------------	-----------------

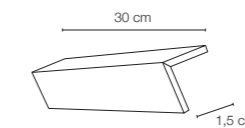

PERFIL BIANCO

1,5x30	RECT	[1,5x29,6x0,90 cm]	P20 /peça_piece
--------	------	----------------------	-----------------

Perfil: Peças produzidas sob encomenda.
Perfil: Pieces produced on order.
Perfil: Pièces produites sur commande.
Perfil: Piezas producidas por encargo.

Veios suaves, delicados e imprevisíveis, que conferem elegância e glamour.
Gentle, delicate and unpredictable rays, conveying elegance and glamour.
Des veines douces, délicates et imprévisibles, qui confèrent de l'élégance et du glamour.
Vetas suaves, delicadas e imprevisibles, que aportan elegancia y glamur.

Pulpis



Pulpis Bege
Magnus Bege
Pulpis Tabac



Pulpis Platina
Antislip Forest Gris
Pulpis Gris

Pulpis

04 cores color s
couleurs colors

03 formatos formats
formats formats

02 acabamentos finishes
finishes finitions
acabados acabados

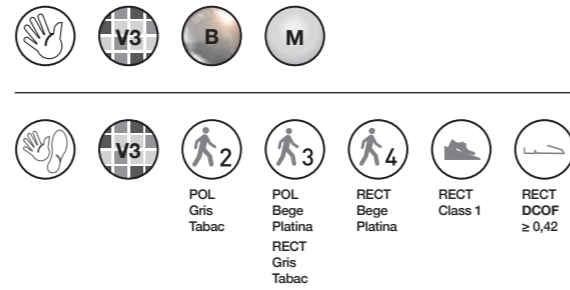

13
Até 13 desenhos
Up to 13 designs
Jusqu'à 13 dessins
Hasta 13 diseños

GRAPHIC VARIATION

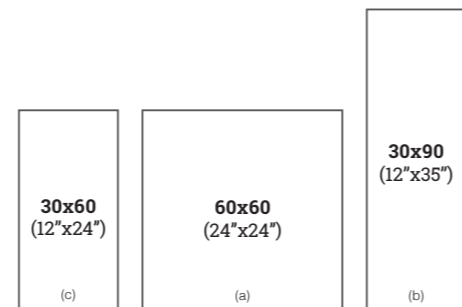

- (a) - Pulpis
- (b) - Pulpis · Pulpis Wave
- (c) - Pulpis · Pulpis Signus

Peças / Pieces	Espessura (mm) Thickness (mm)	Caixa / Box		Europaleta / Europallet			
		Nº Peças No Pieces	M² Aprox. No of Sq. M. Approx.	Peso (Kg) Weight Kg	Nº Caixas No Boxes	M² Aprox. No of Sq. M. Approx.	Peso (Kg) Weight (Kg)
30x60 cm	Rect. ± 9,0 ± 5 %	5	0.90	14.5	72	64.80	1 065
60x60 cm	Rect. ± 9,8 ± 5 %	4	1.44	33.0	32	46.08	1 077
	Pol. ± 9,8 ± 5 %	4	1.44	33.0	32	46.08	1 077
30x90 cm	Rect. ± 12,3 ± 0,5 mm	4	1.08	22.0	40	43.20	901

De modo a proteger a superfície das peças, os produtos no acabamento polido têm uma fina camada de impermeabilizante, que apenas deve ser removida após a conclusão da obra.
Tiles with polished finish are protected with waterproof coating that must be removed only after the works are concluded.
En vue de protéger la surface des pièces, les produits à la finition polie ont une fine couche d'imperméabilisant qui ne devrait être enlevée qu'après l'achèvement des travaux.
Con el fin de proteger la superficie de las piezas, los productos con acabado pulido tienen una fina capa de impermeabilizante, que solo debe eliminarse una vez terminado el trabajo.

Pulpis



PULPIS BEGE

60x60	RECT	[59,2x59,2x0,98 cm]	P91	V3	4	class 1	≥0,42
	POL	[59,2x59,2x0,98 cm]	P105	V3	3	—	—

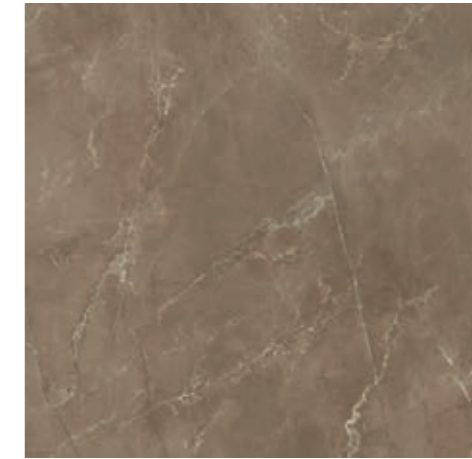

PULPIS TABAC

60x60	RECT	[59,2x59,2x0,98 cm]	P91	V3	3	class 1	≥0,42
	POL	[59,2x59,2x0,98 cm]	P105	V3	2	—	—

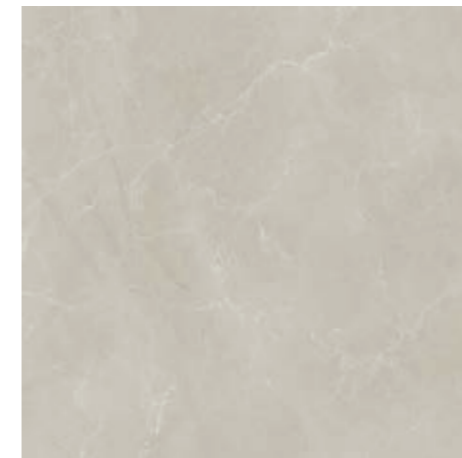

PULPIS PLATINA

60x60	RECT	[59,2x59,2x0,98 cm]	P91	V3	4	class 1	≥0,42
	POL	[59,2x59,2x0,98 cm]	P105	V3	3	—	—

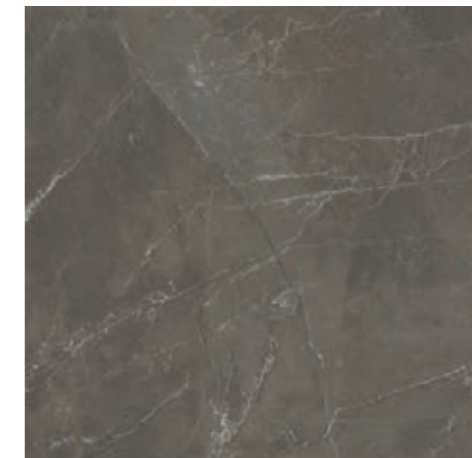

PULPIS GRIS

60x60	RECT	[59,2x59,2x0,98 cm]	P91	V3	3	class 1	≥0,42
	POL	[59,2x59,2x0,98 cm]	P105	V3	2	—	—

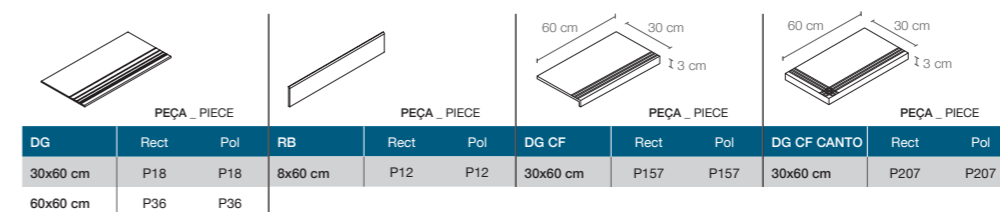

DG	Rect	Pol	RB	Rect	Pol	DG CF	Rect	Pol	DG CF CANTO	Rect	Pol
30x60 cm	P18	P18	8x60 cm	P12	P12	30x60 cm	P157	P157	30x60 cm	P207	P207
60x60 cm	P36	P36									

DG CF / DG CF Canto: Peças produzidas sob encomenda.
DG CF / DG CF Canto: Pieces produced on order.
DG CF / DG CF Canto: Pièces produites sur commande
DG CF / DG CF Canto: Piezas producidas por encargo

DG CF Canto: Disponível em canto esquerdo e direito.
DG CF Canto: Available in left and right corner.
DG CF Canto: Disponible en angle gauche et droit.
DG CF Canto: Canto izquierdo y derecho disponibles.

Tendo em vista alcançar um efeito global mais real e harmonioso, são produzidas peças diferentes umas das outras com variações de desenho e/ou cores entre elas.
For a more genuine and harmonious effect overall, different tiles with design and/or colour variations are produced.
Afin d'obtenir un effet global plus réel et harmonieux, nos pièces sont différentes les unes des autres avec des variations de dessin et / ou de nuances entre elles.
Para lograr un efecto global más real y armonioso, se producen piezas diferentes unas de otras con variaciones de diseño y/o color.

Pulpis



Pulpis



PULPIS BEGE BRILHO

30x90	RECT	[29,6x88,8x1,23 cm]	P92
30x60	RECT	[29,6x59,2x0,90 cm]	P75

PULPIS BEGE MATE

30x90	RECT	[29,6x88,8x1,23 cm]	P92
30x60	RECT	[29,6x59,2x0,90 cm]	P75



PULPIS TABAC BRILHO

30x90	RECT	[29,6x88,8x1,23 cm]	P92
30x60	RECT	[29,6x59,2x0,90 cm]	P75

PULPIS TABAC MATE

30x90	RECT	[29,6x88,8x1,23 cm]	P92
30x60	RECT	[29,6x59,2x0,90 cm]	P75

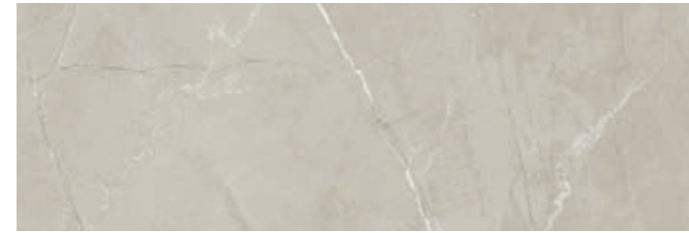

PULPIS PLATINA BRILHO

30x90	RECT	[29,6x88,8x1,23 cm]	P92
30x60	RECT	[29,6x59,2x0,90 cm]	P75

PULPIS PLATINA MATE

30x90	RECT	[29,6x88,8x1,23 cm]	P92
30x60	RECT	[29,6x59,2x0,90 cm]	P75

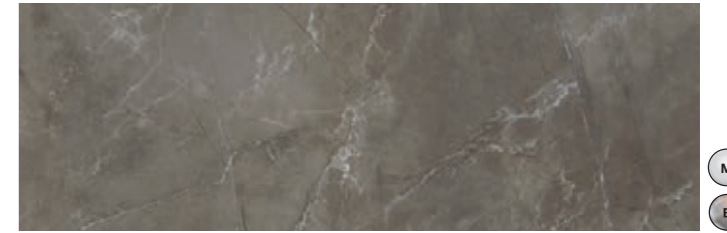

PULPIS GRIS BRILHO

30x90	RECT	[29,6x88,8x1,23 cm]	P92
30x60	RECT	[29,6x59,2x0,90 cm]	P75

PULPIS GRIS MATE

30x90	RECT	[29,6x88,8x1,23 cm]	P92
30x60	RECT	[29,6x59,2x0,90 cm]	P75



PULPIS WAVE BEGE BRILHO (*)

30x90	RECT	[29,6x88,8x1,23 cm]	P95
-------	------	-----------------------	-----

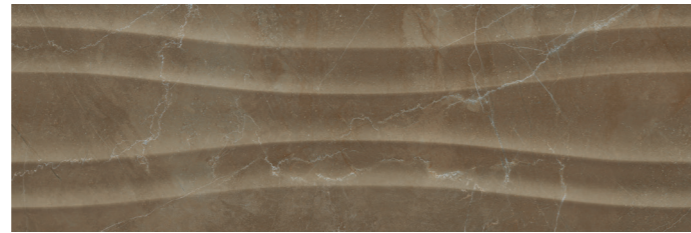

PULPIS WAVE TABAC BRILHO (*)

30x90	RECT	[29,6x88,8x1,23 cm]	P95
-------	------	-----------------------	-----



PULPIS WAVE PLATINA BRILHO (*)

30x90	RECT	[29,6x88,8x1,23 cm]	P95
-------	------	-----------------------	-----

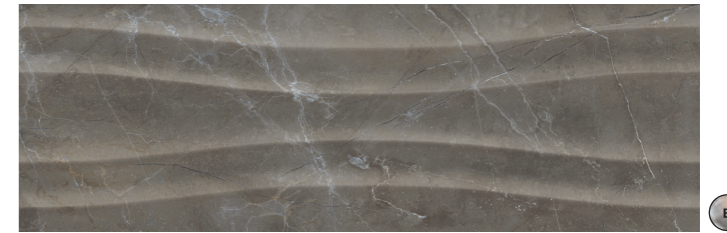

PULPIS WAVE GRIS BRILHO (*)

30x90	RECT	[29,6x88,8x1,23 cm]	P95
-------	------	-----------------------	-----

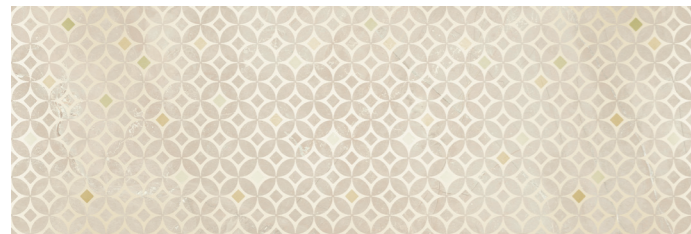

MAGNUS BEGE

30x90	RECT	[29,6x88,8x1,23 cm]	P91 / peça_piece
-------	------	-----------------------	------------------



MAGNUS TABAC

30x90	RECT	[29,6x88,8x1,23 cm]	P91 / peça_piece
-------	------	-----------------------	------------------



MAGNUS PLATINA

30x90	RECT	[29,6x88,8x1,23 cm]	P91 / peça_piece
-------	------	-----------------------	------------------

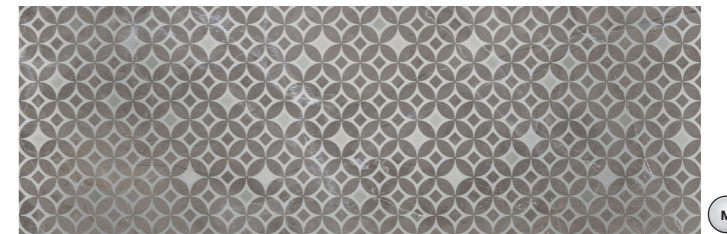

MAGNUS GRIS

30x90	RECT	[29,6x88,8x1,23 cm]	P91 / peça_piece
-------	------	-----------------------	------------------



PULPIS SIGNUS BEGE BRILHO

30x60	RECT	[29,6x59,2x0,90 cm]	P80
-------	------	-----------------------	-----



PULPIS SIGNUS TABAC BRILHO

30x60	RECT	[29,6x59,2x0,90 cm]	P80
-------	------	-----------------------	-----



PULPIS SIGNUS PLATINA BRILHO

30x60	RECT	[29,6x59,2x0,90 cm]	P80
-------	------	-----------------------	-----



PULPIS SIGNUS GRIS BRILHO

30x60	RECT	[29,6x59,2x0,90 cm]	P80
-------	------	-----------------------	-----



VERSUS PULPIS BEGE (a) (b)

30x30	P34 / peça_piece
-------	------------------

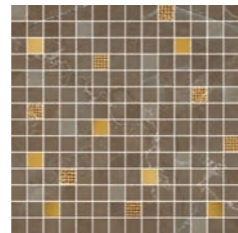

VERSUS PULPIS TABAC (a) (b)

30x30	P34 / peça_piece
-------	------------------



VERSUS PULPIS PLATINA (a) (b)

30x30	P34 / peça_piece
-------	------------------

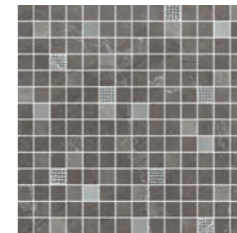

VERSUS PULPIS GRIS (a) (b)

30x30	P34 / peça_piece
-------	------------------

Tendo em vista alcançar um efeito global mais real e harmonioso, são produzidas peças diferentes umas das outras com variações de desenho e/ou cores entre elas.

For a more genuine and harmonious effect overall, different tiles with design and/or colour variations are produced.

Afin d'obtenir un effet global plus réel et harmonieux, nos pièces sont différentes les unes des autres avec des variations de dessin et / ou de nuances entre elles.

Para lograr un efecto global más real y armonioso, se producen piezas diferentes unas de otras con variaciones de diseño y/o color.

(*) Dado o efeito deste produto, as peças devem ser aplicadas sempre no mesmo sentido.

(*) Given the effect of this product, the pieces must always be applied in the same direction.

(*) En raison de l'effet de ce produit, les pièces doivent être toujours appliquées dans le même direction.

(*) Dado el efecto de este producto, las piezas siempre deben aplicarse en el mismo sentido.

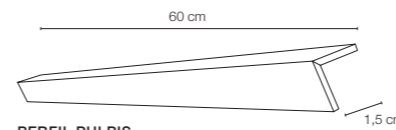

PERFIL PULPIS

1,5x60	RECT	[1,5x59,2x0,90 cm]	P32 / peça_piece
--------	------	----------------------	------------------

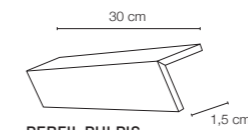

PERFIL PULPIS

1,5x30	RECT	[1,5x29,6x0,90 cm]	P20 / peça_piece
--------	------	----------------------	------------------

Perfil: Peças produzidas sob encomenda.

Perfil: Pieces produced on order.

Perfil: Pièces produites sur commande.

Perfil: Piezas producidas por encargo.

A reinterpretação dos mármore clássicos para ambientes contemporâneos.
The reinterpretation of classic marbles in modern environments.
La réinterprétation des marbres classiques pour des atmosphères contemporaines.
La reinterpretación de los mármoles clásicos para ambientes contemporâneos.

Tuscania



Tuscania Bege Brilho
Arcadia Bege Brilho
Jinko Pepper



Tuscania Bege Brilho
Tuscania Romano Brilho
Tuscania Bege

01 cor
color
couleur
color

03 formatos
formats
formats
formats

02 acabamentos
finishes
finitions
acabados

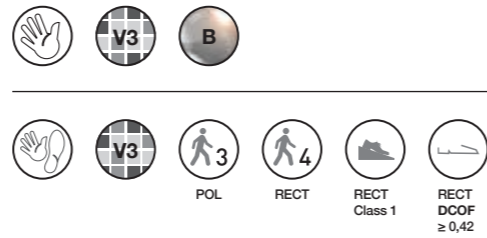

Tuscania



7
Até 7 desenhos
Up to 7 designs
Jusqu'à 7 dessins
Hasta 7 diseños

GRAPHIC VARIATION

- (a) - Tuscania Bege
- (b) - Tuscania · Tuscania Wave Brilho · Tuscania Romano Brilho
- (c) - Tuscania · Tuscania Pompeia Brilho

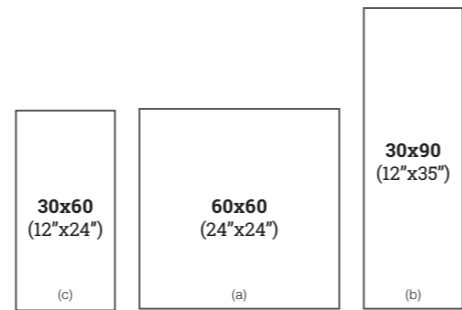

Peças / Pieces		Caixa / Box		Europaleta / Europallet				
	Espeçura (mm) Thickness (mm)	Nº Peças No Pieces	M² Aprox. No of Sq. M. Approx.	Peso (Kg) Weight Kg	Nº Caixas No Boxes	M² Aprox. No of Sq. M. Approx.	Peso (Kg) Weight (Kg)	
30x60 cm	Rect.	± 9,0 ± 5 %	5	0.90	14.5	72	64.80	1 065
60x60 cm	Rect.	± 9,8 ± 5 %	4	1.44	33.0	32	46.08	1 077
	Pol.	± 9,8 ± 5 %	4	1.44	33.0	32	46.08	1 077
30x90 cm	Rect.	± 12,3 ± 0,5 mm	4	1.08	22.0	40	43.20	901

De modo a proteger a superfície das peças, os produtos no acabamento polido têm uma fina camada de impermeabilizante, que apenas deve ser removida após a conclusão da obra.
Tiles with polished finish are protected with waterproof coating that must be removed only after the works are concluded.
En vue de protéger la surface des pièces, les produits à la finition polie ont une fine couche d'imperméabilisant qui ne devrait être enlevée qu'après l'achèvement des travaux.
Con el fin de proteger la superficie de las piezas, los productos con acabado pulido tienen una fina capa de impermeabilizante, que solo debe eliminarse una vez terminado el trabajo.



TUSCANIA BEGE BRILHO				
30x90	RECT	[29,6x88,8x1,23 cm]	P92	
30x60	RECT	[29,6x59,2x0,90 cm]	P75	



TUSCANIA ROMANO BRILHO				
30x90	RECT	[29,6x88,8x1,23 cm]	P95	



TUSCANIA WAVE BEGE BRILHO (*)				
30x90	RECT	[29,6x88,8x1,23 cm]	P95	

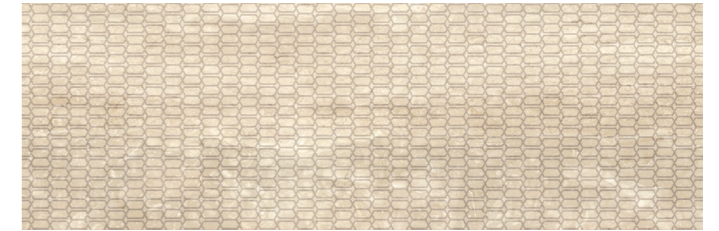

ARCADIA BEGE BRILHO				
30x90	RECT	[29,6x88,8x1,23 cm]	P95	



TUSCANIA POMPEIA BRILHO				
30x60	RECT	[29,6x59,2x0,90 cm]	P80	

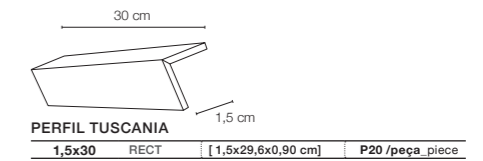
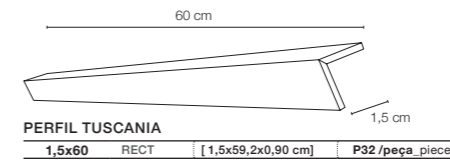

- (*) Dado o efeito deste produto, as peças devem ser aplicadas sempre no mesmo sentido.
(*) Given the effect of this product, the pieces must always be applied in the same direction.
(*) En raison de l'effet de ce produit, les pièces doivent être toujours appliquées dans le même direction.
(*) Dado el efecto de este producto, las piezas siempre deben aplicarse en el mismo sentido.

Perfil: Peças produzidas sob encomenda.
Perfil: Pieces produced on order.
Perfil: Pièces produites sur commande.
Perfil: Piezas producidas por encargo.

COORDENADOS · MATCHING · COORDONNÉS · COORDINADOS



TUSCANIA BEGE							
60x60	RECT	[59,2x59,2x0,98 cm]	P91	V3	4	class 1	≥0,42
	POL	[59,2x59,2x0,98 cm]	P105	V3	3	—	—

PEÇA _ PIECE		PEÇA _ PIECE	
DG	Rect	Pol	RB
30x60 cm	P18	P18	8x60 cm
60x60 cm	P36	P36	P12

PEÇA _ PIECE		PEÇA _ PIECE	
DG CF	Rect	Pol	DG CF CANTO
30x60 cm	P157	P157	30x60 cm
			P207

DG CF / DG CF Canto: Peças produzidas sob encomenda.
DG CF / DG CF Canto: Pieces produced on order.
DG CF / DG CF Canto: Pièces produites sur commande
DG CF / DG CF Canto: Piezas producidas por encargo

DG CF Canto: Disponível em canto esquerdo e direito.
DG CF Canto: Available in left and right corner.
DG CF Canto: Disponible en angle gauche et droit.
DG CF Canto: Canto izquierdo y derecho disponibles.

Tendo em vista alcançar um efeito global mais real e harmonioso, são produzidas peças diferentes umas das outras com variações de desenho e/ou cores entre elas.
For a more genuine and harmonious effect overall, different tiles with design and/or colour variations are produced.
Afin d'obtenir un effet global plus réel et harmonieux, nos pièces sont différentes les unes des autres avec des variations de dessin et / ou de nuances entre elles.
Para lograr un efecto global más real y armonioso, se producen piezas diferentes unas de otras con variaciones de diseño y/o color.

O branco imaculado da pedra natural para ambientes elegantes.
Immaculate white of natural stone for elegant environments.
Le blanc immaculé de la pierre naturelle pour les ambiances élégantes.
El blanco imaculado de la piedra natural para ambientes elegantes.

Onix



Onix White Brilho
Vertex Brilho
Forest Nude
Onix White



Onix White Brilho
Lux Gold Onix
Lavastone Antracite
Onix White

01 cor
color
couleur
color

03 formatos
formats
formats
formats

02 acabamentos
finishes
finitions
acabados

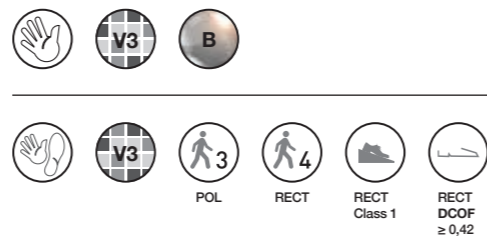

8

Até 8 desenhos
Up to 8 designs
Jusqu'à 8 dessins
Hasta 8 diseños

GRAPHIC VARIATION

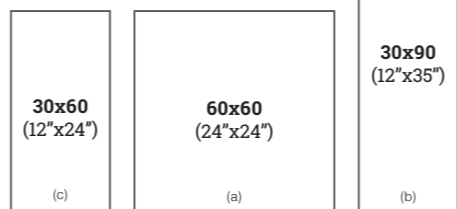

(a) - Onix
(b) - Onix · Onix Compass
(c) - Onix · Onix Opera

Peças / Pieces		Caixa / Box			Europaleta / Europallet			
	Espeçura (mm) Thickness (mm)	Nº Peças No Pieces	M² Aprox. No of Sq. M. Approx.	Peso (Kg) Weight Kg	Nº Caixas No Boxes	M² Aprox. No of Sq. M. Approx.	Peso (Kg) Weight (Kg)	
30x60 cm	Rect.	± 9,0 ± 5 %	5	0.90	14.5	72	64.80	1 065
60x60 cm	Rect.	± 9,8 ± 5 %	4	1.44	33.0	32	46.08	1 077
	Pol.	± 9,8 ± 5 %	4	1.44	33.0	32	46.08	1 077
30x90 cm	Rect.	± 12,3 ± 0,5 mm	4	1.08	22.0	40	43.20	901

De modo a proteger a superfície das peças, os produtos no acabamento polido têm uma fina camada de impermeabilizante, que apenas deve ser removida após a conclusão da obra.
Tiles with polished finish are protected with waterproof coating that must be removed only after the works are concluded.

En vue de protéger la surface des pièces, les produits à la finition polie ont une fine couche d'imperméabilisant qui ne devrait être enlevée qu'après l'achèvement des travaux.
Con el fin de proteger la superficie de las piezas, los productos con acabado pulido tienen una fina capa de impermeabilizante, que solo debe eliminarse una vez terminado el trabajo.



ONIX WHITE BRILHO				
30x90	RECT	[29,6x88,8x1,23 cm]	P92	
30x60	RECT	[29,6x59,2x0,90 cm]	P75	



ONIX COMPASS BRILHO				
30x90	RECT	[29,6x88,8x1,23 cm]	P95	

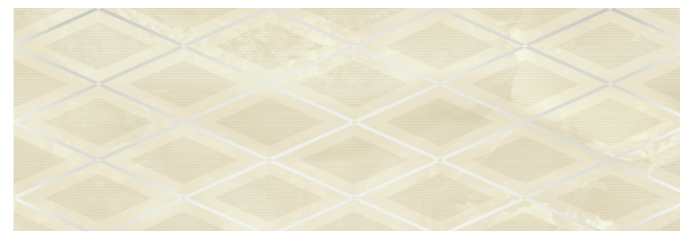

VERTIX BRILHO				
30x90	RECT	[29,6x88,8x1,23 cm]	P91 / peça_pieza	

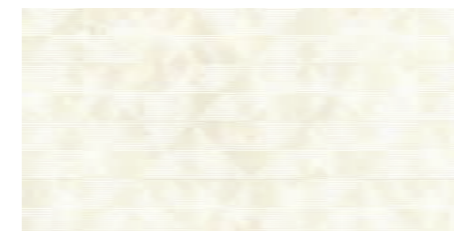

ONIX OPERA BRILHO				
30x60	RECT	[29,6x59,2x0,90 cm]	P80	



LUX GOLD ONIX (a)				
30x30	P26 / peça_pieza			



LUX ONIX (a)				
30x30	P21 / peça_pieza			

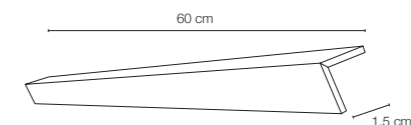

PERFIL ONIX				
1,5x60	RECT	[1,5x59,2x0,90 cm]	P32 / peça_pieza	

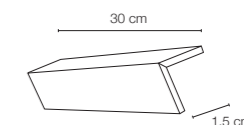

PERFIL ONIX				
1,5x30	RECT	[1,5x29,6x0,90 cm]	P20 / peça_pieza	

Perfil: Peças produzidas sob encomenda.
Perfil: Pieces produced on order.
Perfil: Pièces produites sur commande.
Perfil: Piezas producidas por encargo.

COORDENADOS · MATCHING · COORDONNÉS · COORDINADOS



ONIX WHITE									
60x60	RECT	[59,2x59,2x0,98 cm]	P91	V3	4	class 1	≥0,42		
	POL	[59,2x59,2x0,98 cm]	P105	V3	3				

PEÇA / PIECE		PEÇA / PIECE	
DG	Rect	Pol	RB
30x60 cm	P18	P18	8x60 cm
60x60 cm	P36	P36	P12

PEÇA / PIECE		PEÇA / PIECE	
DG CF	Rect	Pol	DG CF CANTO
30x60 cm	P157	P157	30x60 cm
			P207

DG CF / DG CF Canto: Peças produzidas sob encomenda.
DG CF / DG CF Canto: Pieces produced on order.
DG CF / DG CF Canto: Pièces produites sur commande
DG CF / DG CF Canto: Piezas producidas por encargo

DG CF Canto: Disponível em canto esquerdo e direito.
DG CF Canto: Available in left and right corner.
DG CF Canto: Disponible en angle gauche et droit.
DG CF Canto: Canto izquierdo y derecho disponibles.

Tendo em vista alcançar um efeito global mais real e harmonioso, são produzidas peças diferentes umas das outras com variações de desenho e/ou cores entre elas.
For a more genuine and harmonious effect overall, different tiles with design and/or colour variations are produced.

Afin d'obtenir un effet global plus réel et harmonieux, nos pièces sont différentes les unes des autres avec des variations de dessin et / ou de nuances entre elles.
Para lograr un efecto global más real y armonioso, se producen piezas diferentes unas de otras con variaciones de diseño y/o color.

Tons suaves para atmosferas cheias de luz.
Soft shades for bright atmospheres.
Tonalités douces pour des atmosphères remplies de lumière.
Tonos suaves para atmósferas llenas de luz.

Moka



Moka Creme Brilho
Moka Charm Brilho
Moka Creme



Moka Wave Creme Brilho
Moka Craft Brilho
Moka Creme

02 cores
colors
couleurs
colors

03 formatos
formats
formats
formats

02 acabamentos
finishes
finitions
acabados

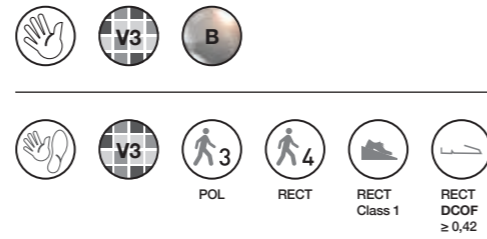

Creme



GRAPHIC VARIATION

Craft

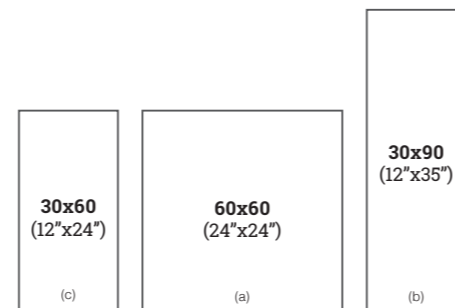

- (a) - Moka Creme
- (b) - Moka - Moka Wave - Moka Flirt
- (c) - Moka - Moka Charm

Peças / Pieces	Espessura (mm) / Thickness (mm)	Caixa / Box		Europaleta / Europallet		
		Nº Peças / No Pieces	M² Aprox. / No of Sq. M. Approx.	Nº Caixas / No Boxes	M² Aprox. / No of Sq. M. Approx.	Peso (Kg) / Weight (Kg)
30x60 cm	Rect. ± 9,0 ± 5 %	5	0.90	72	64.80	1 173
60x60 cm	Rect. ± 8,5 ± 5 %	4	1.44	36	51.84	1 054
	Pol. ± 8,0 ± 5 %	4	1.44	36	51.84	982
30x90 cm	Rect. ± 12,3 ± 0,5 mm	4	1.08	40	43.20	901

De modo a proteger a superfície das peças, os produtos no acabamento polido têm uma fina camada de impermeabilizante, que apenas deve ser removida após a conclusão da obra.
 Tiles with polished finish are protected with waterproof coating that must be removed only after the works are concluded.
 En vue de protéger la surface des pièces, les produits à la finition polie ont une fine couche d'imperméabilisant qui ne devrait être enlevée qu'après l'achèvement des travaux.
 Con el fin de proteger la superficie de las piezas, los productos con acabado pulido tienen una fina capa de impermeabilizante, que solo debe eliminarse una vez terminado el trabajo.



Moka Craft Brilho
Moka Flirt Brilho
Moka Creme



MOKA CREME BRILHO					
30x90	RECT	[29,6x88,8x1,23 cm]	P92		
30x60	RECT	[29,6x59,2x0,90 cm]	P75		

MOKA CREME MATE					
30x90	RECT	[29,6x88,8x1,23 cm]	P92		
30x60	RECT	[29,6x59,2x0,90 cm]	P75		



MOKA CHARM BRILHO					
30x60	RECT	[29,6x59,2x0,90 cm]	P80		



MOKA CRAFT BRILHO					
30x90	RECT	[29,6x88,8x1,23 cm]	P92		
30x60	RECT	[29,6x59,2x0,90 cm]	P75		

MOKA CRAFT MATE					
30x90	RECT	[29,6x88,8x1,23 cm]	P92		
30x60	RECT	[29,6x59,2x0,90 cm]	P75		



MOKA FLIRT BRILHO					
30x90	RECT	[29,6x88,8x1,23 cm]	P95		



MOKA WAVE CREME BRILHO (*)					
30x90	RECT	[29,6x88,8x1,23 cm]	P95		

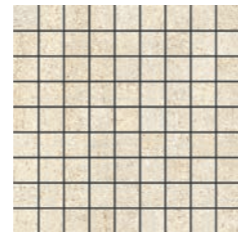

STRATUS 81 MOKA CREME BRILHO (a)					
30x30			P19 / peça_pieza		

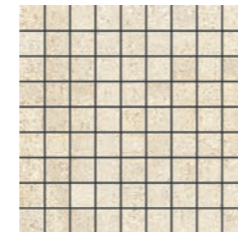

STRATUS 81 MOKA CREME MATE (a)					
30x30			P19 / peça_pieza		

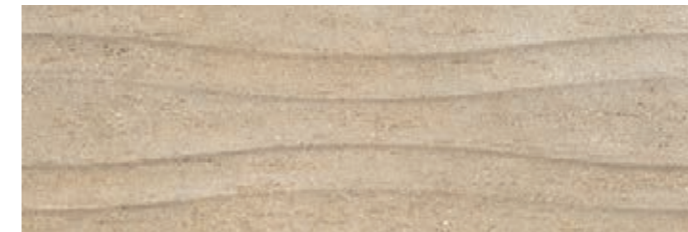

MOKA WAVE CRAFT BRILHO (*)					
30x90	RECT	[29,6x88,8x1,23 cm]	P95		



STRATUS 81 MOKA CRAFT BRILHO (a)					
30x30			P19 / peça_pieza		



STRATUS 81 MOKA CRAFT MATE (a)					
30x30			P19 / peça_pieza		



COORDENADOS · MATCHING · COORDONNÉS · COORDINADOS



DG	PEÇA _PIECE		RB	PEÇA _PIECE	
	Rect	Pol		Rect	Pol
30x60 cm	P18	P18	8x60 cm	P12	P12
60x60 cm	P36	P36			

DG CF	PEÇA _PIECE		DG CF CANTO	PEÇA _PIECE	
	Rect	Pol		Rect	Pol
30x60 cm	P157	P157	30x60 cm	P207	P207

DG CF / DG CF Canto: Peças produzidas sob encomenda.
 DG CF / DG CF Canto: Pieces produced on order.
 DG CF / DG CF Canto: Pièces produites sur commande
 DG CF / DG CF Canto: Piezas producidas por encargo

DG CF Canto: Disponível em canto esquerdo e direito.
 DG CF Canto: Available in left and right corner.
 DG CF Canto: Disponible en angle gauche et droit.
 DG CF Canto: Canto izquierdo y derecho disponibles.

MOKA CREME							
60x60	RECT	[59,2x59,2x0,98 cm]	P91	V3	A4	class 1	≥0,42
	POL	[59,2x59,2x0,98 cm]	P105	V3	A3	—	—

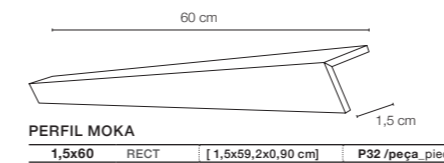

PERFIL MOKA			
1,5x60	RECT	[1,5x59,2x0,90 cm]	P32 /peça_pieza

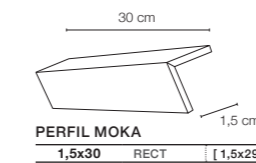

PERFIL MOKA			
1,5x30	RECT	[1,5x29,6x0,90 cm]	P20 /peça_pieza

Perfil: Peças produzidas sob encomenda.
 Perfil: Pieces produced on order.
 Perfil: Pièces produites sur commande.
 Perfil: Piezas producidas por encargo.

(*) Dado o efeito deste produto, as peças devem ser sempre aplicadas no mesmo sentido.
 (*) Given the effect of this product, the pieces must always be applied in the same direction.
 (*) En raison de l'effet de ce produit, les pièces doivent être toujours appliquées dans le même direction.
 (*) Dado el efecto de este producto, las piezas siempre deben aplicarse en el mismo sentido.

Tendo em vista alcançar um efeito global mais real e harmonioso, são produzidas peças diferentes umas das outras com variações de desenho e/ou cores entre elas.
 For a more genuine and harmonious effect overall, different tiles with design and/or colour variations are produced.
 Afin d'obtenir un effet global plus réel et harmonieux, nos pièces sont différentes les unes des autres avec des variations de dessin et / ou de nuances entre elles.
 Para lograr un efecto global más real y armonioso, se producen piezas diferentes unas de otras con variaciones de diseño y/o color.



Stones

Página
Page
Page
Página

Afyon	266
Lavastone	274
Yura	282
Slate	286
Xisto	292

Ligação Natural

Materiais que refletem os traços característicos da pedra natural permitem criar uma ligação entre os espaços e a natureza.

Natural Connection

Using materials that reflect the natural stone characteristic features allows you to create a connection between spaces and nature.

Lien Naturel

L'utilisation de matériaux qui reflètent les caractéristiques de la pierre naturelle vous permet de créer un lien entre les espaces et la nature.

Vínculo Natural

Utilizar materiales que reflejen los rasgos característicos de la piedra natural permite crear un vínculo entre los espacios y la naturaleza.

A riqueza incomparável da pedra natural, numa combinação perfeita entre beleza e resistência.
The unrivalled richness of natural stone in the perfect combination of beauty and resistance.
La richesse incomparable de la pierre naturelle, alliant parfaitement beauté et résistance.
La riqueza incomparable de la piedra natural, en una combinación perfecta entre belleza y resistencia.

Afyon



Afyon Bone
Afyon Grafite

Afyon / Antislip Afyon

Afyon

- 04** cores
couleurs
colors
- 03** formatos
formats
formats
- 02** acabamentos
finishes
finitions
acabados



RECT Class 1
 ANTISLIP Class 3 R11 PTV 36 +
 ANTISLIP B
 ANTISLIP / RECT DCOF $\geq 0,42$



12
 Até 12 desenhos
 Up to 12 designs
 Jusqu'à 12 dessins
 Hasta 12 diseños

GRAPHIC VARIATION

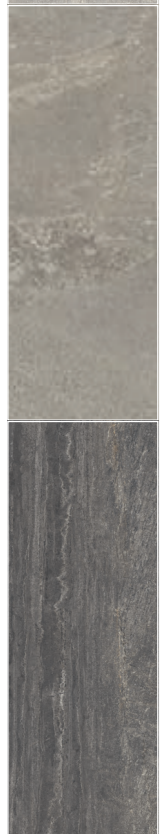

(a) - Afyon
 (b) - Afyon - Antislip Afyon

Peças / Pieces		Espessura (mm) Thickness (mm)	Caixa / Box			Europaleta / Europallet		
			Nº Peças No Pieces	M² Aprox. No of Sq. M. Approx.	Peso (Kg) Weight Kg	Nº Caixas No Boxes	M² Aprox. No of Sq. M. Approx.	Peso (Kg) Weight (Kg)
30x60 cm	Rect.	± 8,5 ±5%	5	0.90	18.0	60	54.00	1 101
60x60 cm	Rect.	± 8,5 ±5%	4	1.44	28.7	36	51.84	1 053
60x120 cm	Rect.	± 9,8 ±5%	2	1.44	33.0	30	43.20	1 011





AFYON BONE

60x120	RECT	[59,2x118,4x0,98 cm]	P117	V4	class 1	≥0,42	U4P3E3C2
30x60	RECT	[29,6x59,2x0,85 cm]	P91	V4	class 1	≥0,42	-



AFYON BONE

60x60	RECT	[59,2x59,2x0,85 cm]	P91	V4	class 1	≥0,42	U4P4E3C2
-------	------	-----------------------	-----	----	---------	-------	----------

ANTISLIP AFYON BONE

60x60	RECT	[59,2x59,2x0,85 cm]	P91	V4	class 3	B	R11	36+	≥0,42
-------	------	-----------------------	-----	----	---------	---	-----	-----	-------



AFYON GRIS

60x120	RECT	[59,2x118,4x0,98 cm]	P117	V4	class 1	≥0,42	U4P3E3C2
30x60	RECT	[29,6x59,2x0,85 cm]	P91	V4	class 1	≥0,42	-

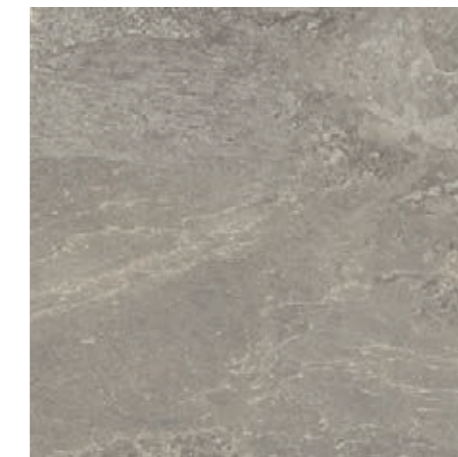

AFYON GRIS

60x60	RECT	[59,2x59,2x0,85 cm]	P91	V4	class 1	≥0,42	U4P4E3C2
-------	------	-----------------------	-----	----	---------	-------	----------

ANTISLIP AFYON GRIS

60x60	RECT	[59,2x59,2x0,85 cm]	P91	V4	class 3	B	R11	36+	≥0,42
-------	------	-----------------------	-----	----	---------	---	-----	-----	-------



AFYON FOG

60x120	RECT	[59,2x118,4x0,98 cm]	P117	V4	class 1	≥0,42	U4P3E3C2
30x60	RECT	[29,6x59,2x0,85 cm]	P91	V4	class 1	≥0,42	-



AFYON FOG

60x60	RECT	[59,2x59,2x0,85 cm]	P91	V4	class 1	≥0,42	U4P4E3C2
-------	------	-----------------------	-----	----	---------	-------	----------

ANTISLIP AFYON FOG

60x60	RECT	[59,2x59,2x0,85 cm]	P91	V4	class 3	B	R11	36+	≥0,42
-------	------	-----------------------	-----	----	---------	---	-----	-----	-------

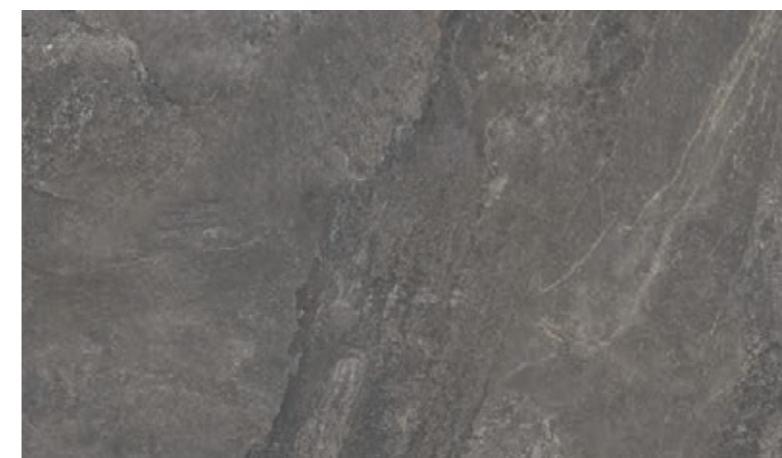

AFYON GRAFITE

60x120	RECT	[59,2x118,4x0,98 cm]	P117	V4	class 1	≥0,42	U4P3E3C2
30x60	RECT	[29,6x59,2x0,85 cm]	P91	V4	class 1	≥0,42	-



AFYON GRAFITE (i)

60x60	RECT	[59,2x59,2x0,85 cm]	P91	V4	class 1	≥0,42	U4P4E3C2
-------	------	-----------------------	-----	----	---------	-------	----------

ANTISLIP AFYON GRAFITE

60x60	RECT	[59,2x59,2x0,85 cm]	P91	V4	class 3	B	R11	36+	≥0,42
-------	------	-----------------------	-----	----	---------	---	-----	-----	-------



ZIG ZAG AFYON BONE (a)
15x45 P28 / peça_piece



ZIG ZAG AFYON FOG (a)
15x45 P28 / peça_piece



TRIO AFYON BONE (a) (f)
20x22 P22 / peça_piece

Base: Afyon Bone, Lavastone Bege, Lavastone Craft



ZIG ZAG AFYON GRIS (a)
15x45 P28 / peça_piece



ZIG ZAG AFYON GRAFITE (a)
15x45 P28 / peça_piece



TRIO AFYON GRIS (a) (f)
20x22 P22 / peça_piece

Base: Afyon Fog, Afyon Grafite, Afyon Gris

Antislip: Produtos que minimizam o risco de deslizamento.
Antislip: Products that minimize the risk of slipping.
Antislip: Produits qui réduisent le risque de glissement.
Antislip: Productos que minimizan el riesgo de deslizamiento.

Tendo em vista alcançar um efeito global mais real e harmonioso, são produzidas peças diferentes umas das outras com variações de desenho e/ou cores entre elas.
 For a more genuine and harmonious effect overall, different tiles with design and/or colour variations are produced.
 Afin d'obtenir un effet global plus réel et harmonieux, nos pièces sont différentes les unes des autres avec des variations de dessin et / ou de nuances entre elles.
 Para lograr un efecto global más real y armonioso, se producen piezas diferentes unas de otras con variaciones de diseño y/o color.



Afyon Fog

ZOOM

DG	Rect	RB	Rect	DG CF	Rect	DG CF CANTO	Rect
30x60 cm	P18	9,5x30 cm	P08	30x60 cm	P157	30x60 cm	P207
60x60 cm	P36	8x60 cm	P12				
30x120 cm	P97	8x120 cm	P28				
60x120 cm	P167						

DG CF / DG CF Canto: Peças produzidas sob encomenda.
 DG CF / DG CF Canto: Pieces produced on order.
 DG CF / DG CF Canto: Pièces produites sur commande
 DG CF / DG CF Canto: Piezas producidas por encargo

DG CF Canto: Disponível em canto esquerdo e direito.
 DG CF Canto: Available in left and right corner.
 DG CF Canto: Disponible en angle gauche et droit.
 DG CF Canto: Canto izquierdo y derecho disponibles.



Afyon Bone
Zig Zag Afyon Bone

A reinterpretação dos minerais da pedra natural para espaços sofisticados.
The reinterpretation of natural minerals for sophisticated spaces.
La réinterprétation des minéraux de la pierre naturelle pour les espaces sophistiqués.
La reinterpretación de los minerales de la piedra natural para espacios sofisticados.

Lavastone



Lavastone Bege
Lavastone Antracite
Deck Teca

Lavastone

06 cores
couleurs
colors

04 formatos
formats
formats

02 acabamentos
finishes
finitions
acabados

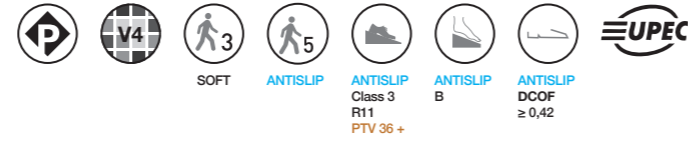

GRAPHIC VARIATION

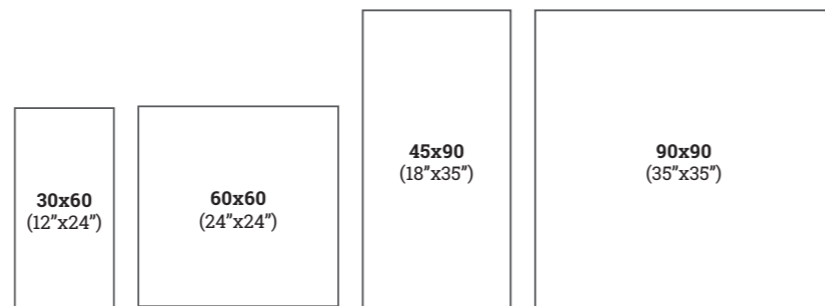

Formato	Acabamento	Peças / Pieces		Caixa / Box		Europaleta / Europallet		
		Espeçura (mm) Thickness (mm)	Nº Peças No Pieces	M² Aprox. No of Sq. M. Approx.	Peso (Kg) Weight (Kg)	Nº Caixas No Boxes	M² Aprox. No of Sq. M. Approx.	Peso (Kg) Weight (Kg)
30x60 cm	Antislip Rect. / Soft	± 8,5 ±5%	5	0.90	18.0	60	54.00	1 101
60x60 cm	Antislip Rect. / Soft	± 8,5 ±5%	4	1.44	28.7	36	51.84	1 053
45x90 cm	Antislip Rect. / Soft	± 10,5 ±0,5 mm	4	1.62	39.0	27	43.74	1 074
90x90 cm	Antislip Rect. / Soft	± 10,5 ±0,5 mm	2	1.62	39.0	24	38.88	991

Lavastone



Lavastone Fog
Jinko Ambar

Lavastone



Lavastone



LAVASTONE BONE

45x90	ANTISLIP RECT	[44,5x89,0x1,05 cm]	P98	V4	class 3	B	R11	36*	≥0,42	U4P3E3C2
	SOFT	[44,5x89,0x1,05 cm]	P98	V4	class 3	B	R11	36*	≥0,42	U4P3E3C2
30x60	ANTISLIP RECT	[29,6x59,2x0,85 cm]	P91	V4	class 3	B	R11	36*	≥0,42	U4P3E3C2
	SOFT	[29,6x59,2x0,85 cm]	P91 <td>V4</td> <td>class 3</td> <td>B</td> <td>R11</td> <td>36*</td> <td>≥0,42</td> <td>U4P3E3C2</td>	V4	class 3	B	R11	36*	≥0,42	U4P3E3C2



LAVASTONE BONE

90x90	ANTISLIP RECT	[89,0x89,0x1,05 cm]	P117	V4	class 3	B	R11	36*	≥0,42	U4P3E3C2
	SOFT	[89,0x89,0x1,05 cm] <th>P117</th> <td>V4</td> <td>class 3</td> <td>B</td> <td>R11</td> <td>36*</td> <td>≥0,42 <td>U4P3E3C2</td> </td>	P117	V4	class 3	B	R11	36*	≥0,42 <td>U4P3E3C2</td>	U4P3E3C2
60x60	ANTISLIP RECT	[59,2x59,2x0,85 cm]	P91	V4	class 3	B	R11	36*	≥0,42	U4P3E3C2
	SOFT	[59,2x59,2x0,85 cm] <th>P91</th> <td>V4</td> <td>class 3</td> <td>B</td> <td>R11</td> <td>36*</td> <td>≥0,42 <td>U4P3E3C2</td> </td>	P91	V4	class 3	B	R11	36*	≥0,42 <td>U4P3E3C2</td>	U4P3E3C2



LAVASTONE CRAFT

45x90	ANTISLIP RECT	[44,5x89,0x1,05 cm]	P98	V4	class 3	B	R11	36*	≥0,42	U4P3E3C2
	SOFT	[44,5x89,0x1,05 cm] <th>P98</th> <td>V4</td> <td>class 3</td> <td>B</td> <td>R11</td> <td>36*</td> <td>≥0,42 <td>U4P3E3C2</td> </td>	P98	V4	class 3	B	R11	36*	≥0,42 <td>U4P3E3C2</td>	U4P3E3C2
30x60	ANTISLIP RECT	[29,6x59,2x0,85 cm]	P91	V4	class 3	B	R11	36*	≥0,42	U4P3E3C2
	SOFT	[29,6x59,2x0,85 cm] <th>P91</th> <td>V4</td> <td>class 3</td> <td>B</td> <td>R11</td> <td>36*</td> <td>≥0,42 <td>U4P3E3C2</td> </td>	P91	V4	class 3	B	R11	36*	≥0,42 <td>U4P3E3C2</td>	U4P3E3C2



LAVASTONE CRAFT

90x90	ANTISLIP RECT	[89,0x89,0x1,05 cm]	P117	V4	class 3	B	R11	36*	≥0,42	U4P3E3C2
	SOFT	[89,0x89,0x1,05 cm] <th>P117</th> <td>V4</td> <td>class 3</td> <td>B</td> <td>R11</td> <td>36*</td> <td>≥0,42 <td>U4P3E3C2</td> </td>	P117	V4	class 3	B	R11	36*	≥0,42 <td>U4P3E3C2</td>	U4P3E3C2
60x60	ANTISLIP RECT	[59,2x59,2x0,85 cm]	P91	V4	class 3	B	R11	36*	≥0,42	U4P3E3C2
	SOFT	[59,2x59,2x0,85 cm] <th>P91</th> <td>V4</td> <td>class 3</td> <td>B</td> <td>R11</td> <td>36*</td> <td>≥0,42 <td>U4P3E3C2</td> </td>	P91	V4	class 3	B	R11	36*	≥0,42 <td>U4P3E3C2</td>	U4P3E3C2



LAVASTONE BEGE

45x90	ANTISLIP RECT	[44,5x89,0x1,05 cm]	P98	V4	class 3	B	R11	36*	≥0,42	U4P3E3C2
	SOFT	[44,5x89,0x1,05 cm] <th>P98</th> <td>V4</td> <td>class 3</td> <td>B</td> <td>R11</td> <td>36*</td> <td>≥0,42 <td>U4P3E3C2</td> </td>	P98	V4	class 3	B	R11	36*	≥0,42 <td>U4P3E3C2</td>	U4P3E3C2
30x60	ANTISLIP RECT	[29,6x59,2x0,85 cm]	P91	V4	class 3	B	R11	36*	≥0,42	U4P3E3C2
	SOFT	[29,6x59,2x0,85 cm] <th>P91</th> <td>V4</td> <td>class 3</td> <td>B</td> <td>R11</td> <td>36*</td> <td>≥0,42 <td>U4P3E3C2</td> </td>	P91	V4	class 3	B	R11	36*	≥0,42 <td>U4P3E3C2</td>	U4P3E3C2



LAVASTONE BEGE

90x90	ANTISLIP RECT	[89,0x89,0x1,05 cm]	P117	V4	class 3	B	R11	36*	≥0,42	U4P3E3C2
	SOFT	[89,0x89,0x1,05 cm] <th>P117</th> <td>V4</td> <td>class 3</td> <td>B</td> <td>R11</td> <td>36*</td> <td>≥0,42 <td>U4P3E3C2</td> </td>	P117	V4	class 3	B	R11	36*	≥0,42 <td>U4P3E3C2</td>	U4P3E3C2
60x60	ANTISLIP RECT	[59,2x59,2x0,85 cm]	P91	V4	class 3	B	R11	36*	≥0,42	U4P3E3C2
	SOFT	[59,2x59,2x0,85 cm] <th>P91</th> <td>V4</td> <td>class 3</td> <td>B</td> <td>R11</td> <td>36*</td> <td>≥0,42 <td>U4P3E3C2</td> </td>	P91	V4	class 3	B	R11	36*	≥0,42 <td>U4P3E3C2</td>	U4P3E3C2



LAVASTONE PLATINA

45x90	ANTISLIP RECT	[44,5x89,0x1,05 cm]	P98	V4	class 3	B	R11	36*	≥0,42	U4P3E3C2
	SOFT	[44,5x89,0x1,05 cm] <th>P98</th> <td>V4</td> <td>class 3</td> <td>B</td> <td>R11</td> <td>36*</td> <td>≥0,42 <td>U4P3E3C2</td> </td>	P98	V4	class 3	B	R11	36*	≥0,42 <td>U4P3E3C2</td>	U4P3E3C2
30x60	ANTISLIP RECT	[29,6x59,2x0,85 cm]	P91	V4	class 3	B	R11	36*	≥0,42	U4P3E3C2
	SOFT	[29,6x59,2x0,85 cm] <th>P91</th> <td>V4</td> <td>class 3</td> <td>B</td> <td>R11</td> <td>36*</td> <td>≥0,42 <td>U4P3E3C2</td> </td>	P91	V4	class 3	B	R11	36*	≥0,42 <td>U4P3E3C2</td>	U4P3E3C2



LAVASTONE PLATINA

90x90	ANTISLIP RECT	[89,0x89,0x1,05 cm]	P117	V4	class 3	B	R11	36*	≥0,42	U4P3E3C2
	SOFT	[89,0x89,0x1,05 cm] <th>P117</th> <td>V4</td> <td>class 3</td> <td>B</td> <td>R11</td> <td>36*</td> <td>≥0,42 <td>U4P3E3C2</td> </td>	P117	V4	class 3	B	R11	36*	≥0,42 <td>U4P3E3C2</td>	U4P3E3C2
60x60	ANTISLIP RECT	[59,2x59,2x0,85 cm]	P91	V4	class 3	B	R11	36*	≥0,42	U4P3E3C2
	SOFT	[59,2x59,2x0,85 cm] <th>P91</th> <td>V4</td> <td>class 3</td> <td>B</td> <td>R11</td> <td>36*</td> <td>≥0,42 <td>U4P3E3C2</td> </td>	P91	V4	class 3	B	R11	36*	≥0,42 <td>U4P3E3C2</td>	U4P3E3C2

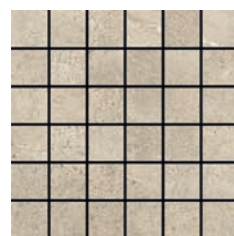

STRATUS 36 LAVASTONE BONE (a) (f)
30x30 ANTISLIP RECT P19 / peça_pieza



STRATUS 36 LAVASTONE BEGE (a) (f)
30x30 ANTISLIP RECT P19 / peça_pieza



TRIO AFYON BONE (a) (f)
20x22 P22 / peça_pieza

Base: Afyon Bone, Lavastone Bege, Lavastone Craft

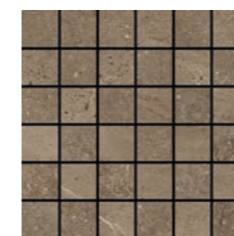

STRATUS 36 LAVASTONE CRAFT (a) (f)
30x30 ANTISLIP RECT P19 / peça_pieza

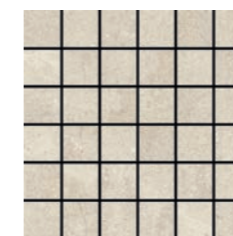

STRATUS 36 LAVASTONE PLATINA (a) (f)
30x30 ANTISLIP RECT P19 / peça_pieza

Tendo em vista alcançar um efeito global mais real e harmonioso, são produzidas peças diferentes umas das outras com variações de desenho e/ou cores entre elas.
For a more genuine and harmonious effect overall, different tiles with design and/or colour variations are produced.
Afin d'obtenir un effet global plus réel et harmonieux, nos pièces sont différentes les unes des autres avec des variations de dessin et / ou de nuances entre elles.
Para lograr un efecto global más real y armonioso, se producen piezas diferentes unas de otras con variaciones de diseño y/o color.

Antislip: Produtos que minimizam o risco de deslizamento.
Antislip: Products that minimize the risk of slipping.
Antislip: Produits qui réduisent le risque de glissement.
Antislip: Productos que minimizan el riesgo de deslizamiento.

Lavastone



Lavastone



LAVASTONE FOG

45x90	ANTISLIP RECT	[44,5x89,0x1,05 cm]	P98	V4	class 3	B	R11	36*	≥0,42	U4P3E3C2
	SOFT	[44,5x89,0x1,05 cm]	P98	V4	class 3	-	-	-	-	-
30x60	ANTISLIP RECT	[29,6x59,2x0,85 cm]	P91	V4	class 3	B	R11	36*	≥0,42	U4P3E3C2
	SOFT	[29,6x59,2x0,85 cm]	P91	V4	class 3	-	-	-	-	-

LAVASTONE FOG

90x90	ANTISLIP RECT	[89,0x89,0x1,05 cm]	P117	V4	class 3	B	R11	36*	≥0,42	U4P3E3C2
	SOFT	[89,0x89,0x1,05 cm]	P117	V4	class 3	-	-	-	-	-
60x60	ANTISLIP RECT	[59,2x59,2x0,85 cm]	P91	V4	class 3	B	R11	36*	≥0,42	U4P3E3C2
	SOFT	[59,2x59,2x0,85 cm]	P91	V4	class 3	-	-	-	-	-



LAVASTONE ANTRACITE

45x90	ANTISLIP RECT	[44,5x89,0x1,05 cm]	P98	V4	class 3	B	R11	36*	≥0,42	U4P3E3C2
	SOFT	[44,5x89,0x1,05 cm]	P98	V4	class 3	-	-	-	-	-
30x60	ANTISLIP RECT	[29,6x59,2x0,85 cm]	P91	V4	class 3	B	R11	36*	≥0,42	U4P3E3C2
	SOFT	[29,6x59,2x0,85 cm]	P91	V4	class 3	-	-	-	-	-

LAVASTONE ANTRACITE

90x90	ANTISLIP RECT	[89,0x89,0x1,05 cm]	P117	V4	class 3	B	R11	36*	≥0,42	U4P3E3C2
	SOFT	[89,0x89,0x1,05 cm]	P117	V4	class 3	-	-	-	-	-
60x60	ANTISLIP RECT	[59,2x59,2x0,85 cm]	P91	V4	class 3	B	R11	36*	≥0,42	U4P3E3C2
	SOFT	[59,2x59,2x0,85 cm]	P91	V4	class 3	-	-	-	-	-



Stones

Stones



STRATUS 36 LAVASTONE FOG (a) (f)
30x30 ANTISLIP RECT (4) P19 / peça_pieça

STRATUS 36 LAVASTONE ANTRACITE (a) (f)
30x30 ANTISLIP RECT (4) P19 / peça_pieça

Tendo em vista alcançar um efeito global mais real e harmonioso, são produzidas peças diferentes umas das outras com variações de desenho e/ou cores entre elas. For a more genuine and harmonious effect overall, different tiles with design and/or colour variations are produced. Afin d'obtenir un effet global plus réel et harmonieux, nos pièces sont différentes les unes des autres avec des variations de dessin et / ou de nuances entre elles. Para lograr un efecto global más real y armonioso, se producen piezas diferentes unas de otras con variaciones de diseño y/o color.

Antislip: Produtos que minimizam o risco de deslizamento. Antislip: Products that minimize the risk of slipping. Antislip: Produits qui réduisent le risque de glissement. Antislip: Productos que minimizan el riesgo de deslizamiento.

ZOOM

DG	PEÇA_PIECE		RB	PEÇA_PIECE		DG CF	PEÇA_PIECE		DG CF CANTO	PEÇA_PIECE	
	Soft	Antislip Rect		Soft	Antislip Rect		Soft	Antislip Rect		Soft	Antislip Rect
30x60 cm	P18	P18	9,5x30 cm	P08	P08	30x60 cm	P157	P157	30x60 cm	P207	P207
60x60 cm	P36	P36	8x45 cm	P16	P16						
45x90 cm	P97	P97	8x60 cm 8x90 cm	P12	P28						

DG CF / DG CF Canto: Peças produzidas sob encomenda. DG CF / DG CF Canto: Pieces produced on order. DG CF / DG CF Canto: Pièces produites sur commande. DG CF / DG CF Canto: Piezas producidas por encargo.

DG CF Canto: Disponível em canto esquerdo e direito. DG CF Canto: Available in left and right corner. DG CF Canto: Disponible en angle gauche et droit. DG CF Canto: Canto izquierdo y derecho disponibles.

O efeito da pedra natural para ambientes robustos ou delicados.
The effect of natural stone for robust or delicate environments.
L'effet de la pierre naturelle pour les ambiances robustes ou délicates.
El efecto de la piedra natural para ambientes robustos o delicados.

Yura



Yura Cinza



Yura Bege

02 cores
couleurs
colors

02 formatos
formats
formats

02 acabamentos
finishes
finitions
acabados

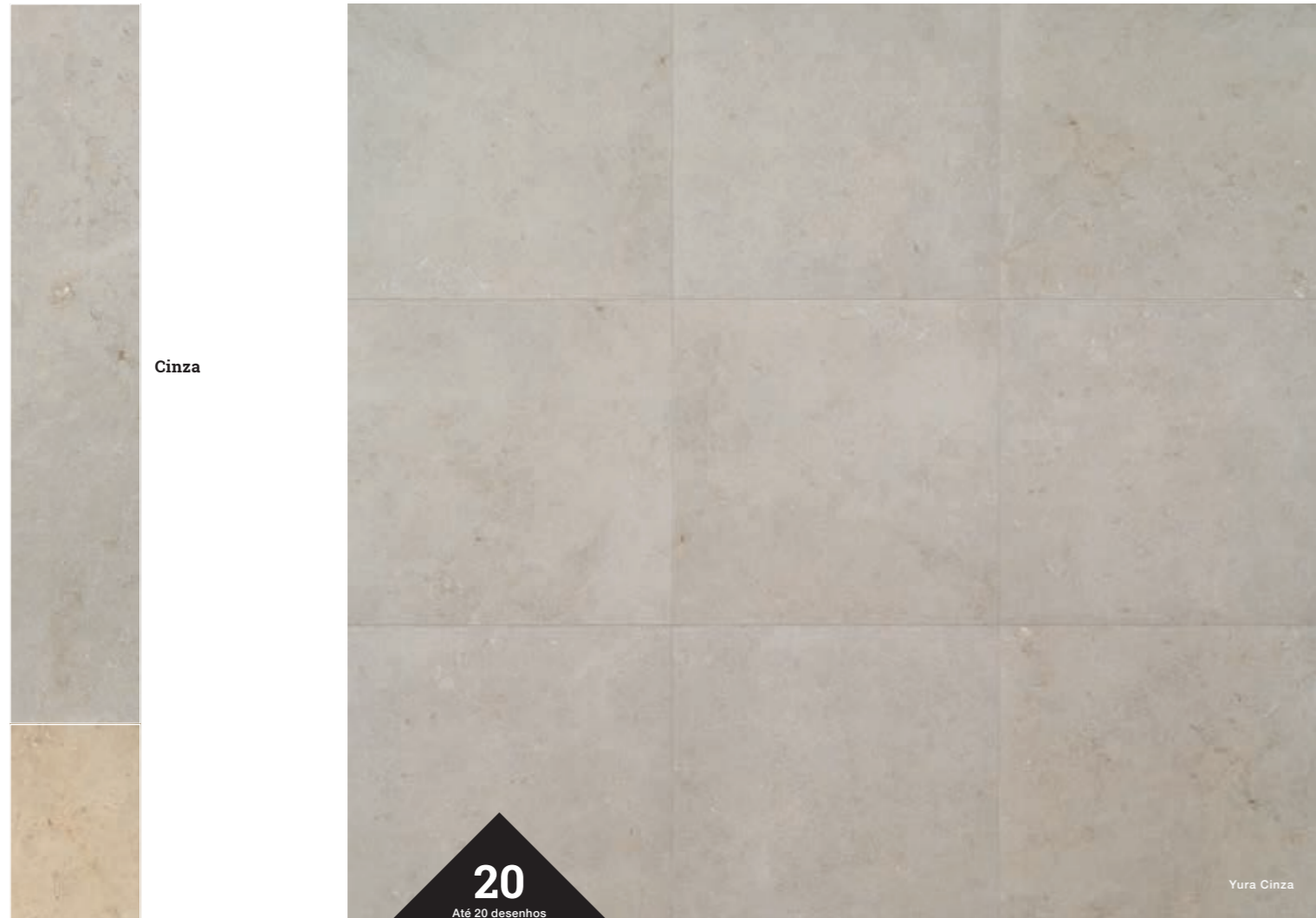

Cinza

Bege

20

Até 20 desenhos
Up to 20 designs
Jusqu'à 20 dessins
Hasta 20 diseños

Yura Cinza

GRAPHIC VARIATION

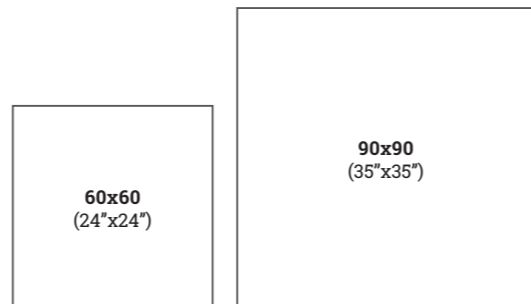

Peças - Pieces		Caixa - Box			Europalette - Europallet			
	Espeçura (mm) Thickness (mm)	Nº Peças No Pieces	M² Aprox. No of Sq. M. Approx.	Peso (Kg) Weight Kg	Nº Caixas No Boxes	M² Aprox. No of Sq. M. Approx.	Peso (Kg) Weight (Kg)	
60x60 cm	Rect./Lap	± 8,5 ±5%	4	1.44	28.7	36	51.84	1 053
90x90 cm	Rect./Lap.	± 10,5 ±0,5 mm	2	1.62	39.0	24	38.88	991



YURA CINZA

90x90	RECT	[89,0x89,0x1,05 cm]	P117	V3	▲4	class 1	≥0,42
	LAP	[89,0x89,0x1,05 cm]	P125	V3	▲3		
60x60	RECT	[59,2x59,2x0,85 cm]	P91	V3	▲4	class 1	≥0,42
	LAP	[59,2x59,2x0,85 cm]	P99	V3	▲3		



YURA BEGE

90x90	RECT	[89,0x89,0x1,05 cm]	P117	V3	▲4	class 1	≥0,42
	LAP	[89,0x89,0x1,05 cm]	P125	V3	▲3		
60x60	RECT	[59,2x59,2x0,85 cm]	P91	V3	▲4	class 1	≥0,42
	LAP	[59,2x59,2x0,85 cm]	P99	V3	▲3		

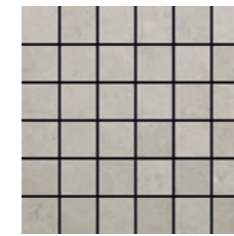

STRATUS 36
YURA CINZA (a), (f)

30x30	P19 / peça_pieza
-------	------------------



STRATUS 36
YURA BEGE (a), (f)

30x30	P19 / peça_pieza
-------	------------------

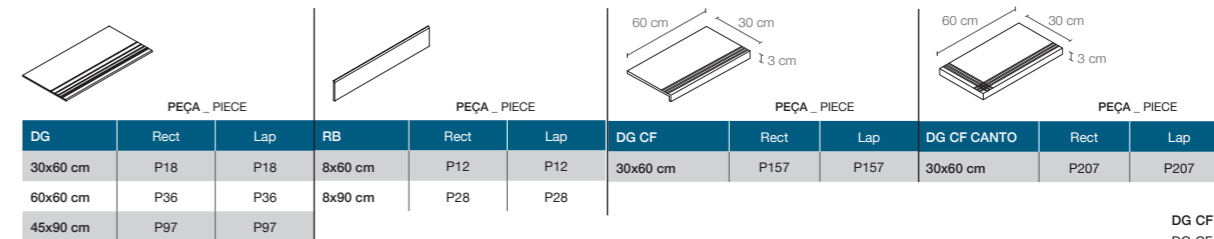

DG	PEÇA - PIECE		RB	PEÇA - PIECE		DG CF	PEÇA - PIECE		DG CF CANTO	PEÇA - PIECE	
	Rect	Lap		Rect	Lap		Rect	Lap		Rect	Lap
30x60 cm	P18	P18	8x60 cm	P12	P12	30x60 cm	P157	P157	30x60 cm	P207	P207
60x60 cm	P36	P36	8x90 cm	P28	P28						
45x90 cm	P97	P97									

DG CF / DG CF Canto: Peças produzidas sob encomenda.
DG CF / DG CF Canto: Pieces produced on order.
DG CF / DG CF Canto: Pièces produites sur commande.
DG CF / DG CF Canto: Piezas producidas por encargo.

Tendo em vista alcançar um efeito global mais real e harmonioso, são produzidas peças diferentes umas das outras com variações de desenho e/ou cores entre elas.
For a more genuine and harmonious effect overall, different tiles with design and/or colour variations are produced.

Afin d'obtenir un effet global plus réel et harmonieux, nos pièces sont différentes les unes des autres avec des variations de dessin et / ou de nuances entre elles.
Para lograr un efecto global más real y armonioso, se producen piezas diferentes unas de otras con variaciones de diseño y/o color.

DG CF Canto: Disponível em canto esquerdo e direito.
DG CF Canto: Available in left and right corner.
DG CF Canto: Disponible en angle gauche et droit.
DG CF Canto: Canto izquierdo y derecho disponibles.

Carácter e tecnología, com o efeito da pedra natural, para ambientes sóbrios, intensos e intemporais.
Character and technology with the natural stone effect for sober, intense and timeless environments.
Caractère et technologie, avec l'effet de la pierre naturelle, pour des ambiances sobres, intenses et intemporelles.
Carácter y tecnología, con el efecto de la piedra natural, para ambientes sobrios, intensos y atemporales.

Slate



Slate Anthracite
Jinko White



Slate Multicolor

02 cores
couleurs
colors

04 formatos
formats
formats

02 acabamentos
finishes
finitions
acabados

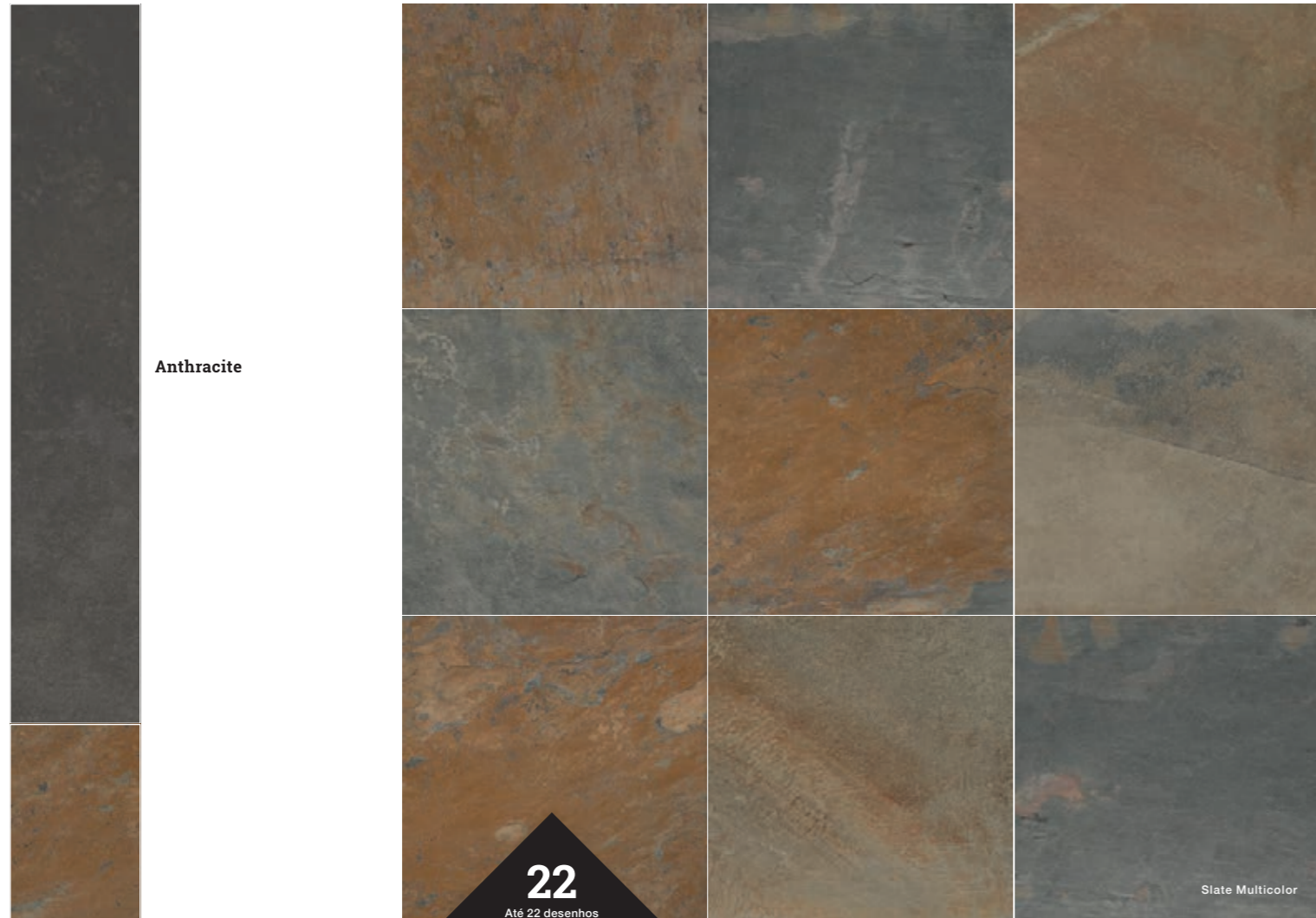
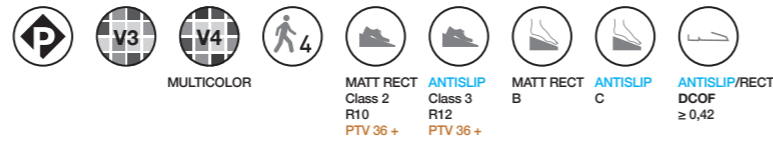

Anthracite

Multicolor

22

Até 22 desenhos
Up to 22 designs
Jusqu'à 22 dessins
Hasta 22 diseños

Slate Multicolor

GRAPHIC VARIATION

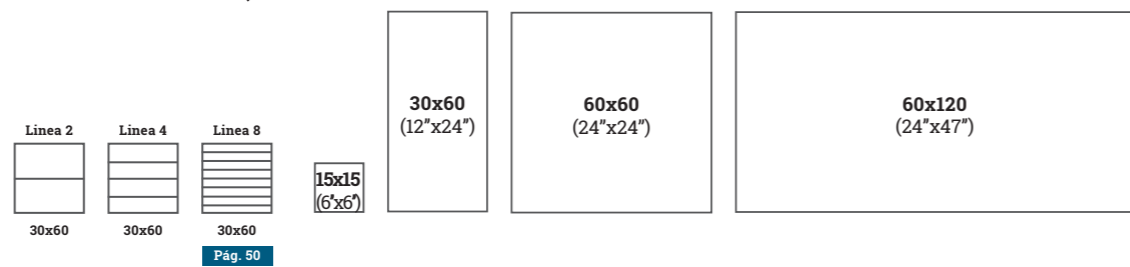

Peças / Pieces	Espessura (mm) Thickness (mm)	Caixa / Box		Europaleta / Europallet		
		Nº Peças No of Pieces	M² Aprox. No of Sq. M. Approx.	Nº Caixas No Boxes	M² Aprox. No of Sq. M. Approx.	Peso (Kg) Weight (Kg)
15x15 cm	± 8,5 ±5%	22	0.50	112	56.00	1 141
30x60 cm	Matt Rect.	5	0.90	48	43.20	885
	Matt Nat.	5	0.90	60	54.00	1 101
60x60 cm	± 8,5 ±5%	4	1.44	36	51.84	1 053
60x120 cm	± 9,8 ±5%	2	1.44	30	43.20	1 011

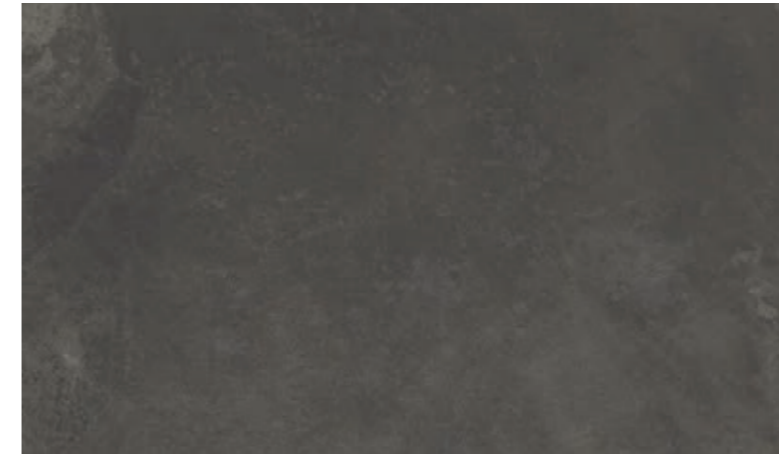

SLATE ANTHRACITE

60x120	MATT RECT	[59,2x118,4x0,98 cm]	P109	V3	4	class 2	B	R10	36+	≥0,42
30x60	MATT NAT	[...x0,85 cm]	P77	V3	4	class 2	B	R10	36+	≥0,42
	MATT RECT	[29,6x59,2x0,85 cm]	P91	V3	4	class 2	B	R10	36+	≥0,42

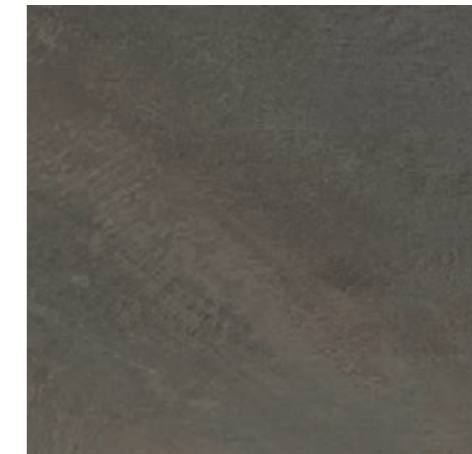

SLATE ANTHRACITE

60x60	MATT RECT	[59,2x59,2x0,85 cm]	P91	V3	4	class 2	B	R10	36+	≥0,42
	ANTISLIP RECT	[59,2x59,2x0,85 cm]	P91	V3	4	class 3	C	R12	36+	≥0,42
15x15	MATT RECT	[14,7x14,7x0,85 cm]	P109	V3	4	class 2	B	R10	36+	≥0,42

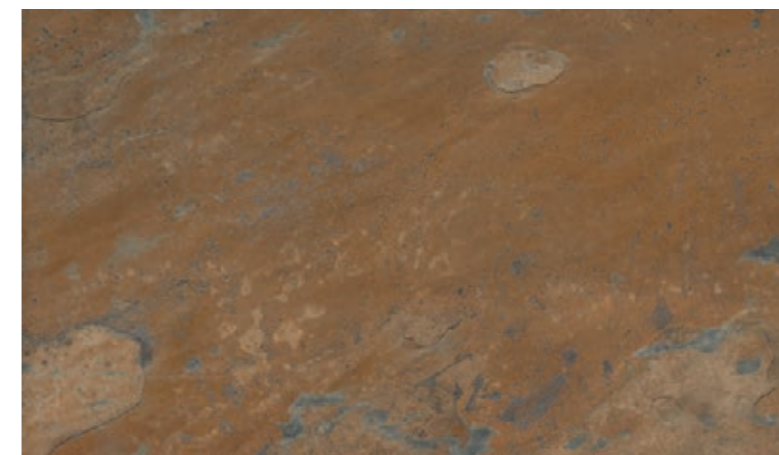

SLATE MULTICOLOR

60x120	MATT RECT	[59,2x118,4x0,98 cm]	P109	V3	4	class 2	B	R10	36+	≥0,42
30x60	MATT NAT	[...x0,85 cm]	P77	V3	4	class 2	B	R10	36+	≥0,42
	MATT RECT	[29,6x59,2x0,85 cm]	P91	V3	4	class 2	B	R10	36+	≥0,42

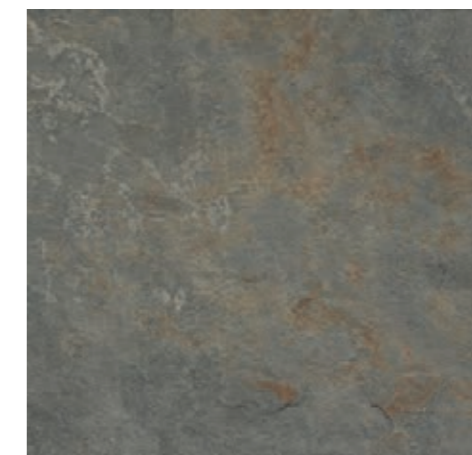

SLATE MULTICOLOR

60x60	MATT RECT	[59,2x59,2x0,85 cm]	P91	V3	4	class 2	B	R10	36+	≥0,42
	ANTISLIP RECT	[59,2x59,2x0,85 cm]	P91	V3	4	class 3	C	R12	36+	≥0,42
15x15	MATT RECT	[14,7x14,7x0,85 cm]	P109	V3	4	class 2	B	R10	36+	≥0,42



STRATUS 9 SLATE ANTHRACITE (a) (f)
30x30 MATT RECT P22 / peça_pieza



STRATUS 9 SLATE MULTICOLOR (a) (f)
30x30 MATT RECT P22 / peça_pieza

Tendo em vista alcançar um efeito global mais real e harmonioso, são produzidas peças diferentes umas das outras com variações de desenho e/ou cores entre elas.
For a more genuine and harmonious effect overall, different tiles with design and/or colour variations are produced.
Afin d'obtenir un effet global plus réel et harmonieux, nos pièces sont différentes les unes des autres avec des variations de dessin et / ou de nuances entre elles.
Para lograr un efecto global más real y armonioso, se producen piezas diferentes unas de otras con variaciones de diseño y/o color.

Antislip: Produtos que minimizam o risco de deslizamento.
Antislip: Products that minimize the risk of slipping.
Antislip: Produits qui réduisent le risque de glissement.
Antislip: Productos que minimizan el riesgo de deslizamiento.

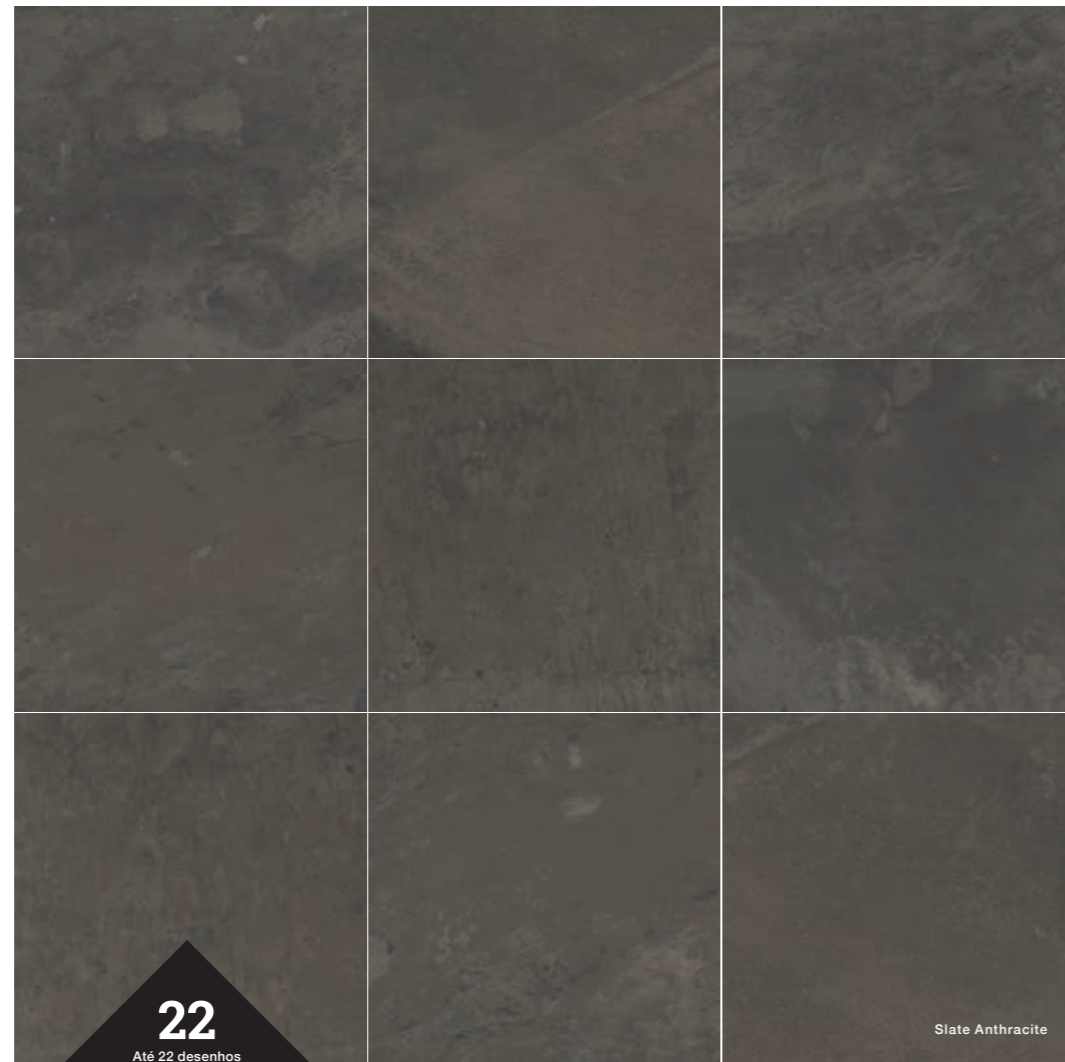

22
Até 22 desenhos
Up to 22 designs
Jusqu'à 22 dessins
Hasta 22 diseños

GRAPHIC VARIATION

DG	Matt Nat	Matt Rect	RB	Matt Nat.	Matt Rect.	DG CF	Matt Rect.	DG CF CANTO	Matt Rect.
30x60 cm	P12	P18	9,5x30 cm	P07	P08	30x60 cm	P157	30x60 cm	P207
60x60 cm	-	P36	8x60 cm	P10	P12				
30x120 cm	-	P97	8x120 cm	-	P28				
60x120 cm	-	P167							

DG CF / DG CF Canto: Peças produzidas sob encomenda.
DG CF / DG CF Canto: Pieces produced on order.
DG CF / DG CF Canto: Pièces produites sur commande.
DG CF / DG CF Canto: Piezas producidas por encargo.

DG CF Canto: Disponível em canto esquerdo e direito.
DG CF Canto: Available in left and right corner.
DG CF Canto: Disponible en angle gauche et droit.
DG CF Canto: Canto izquierdo y derecho disponibles.

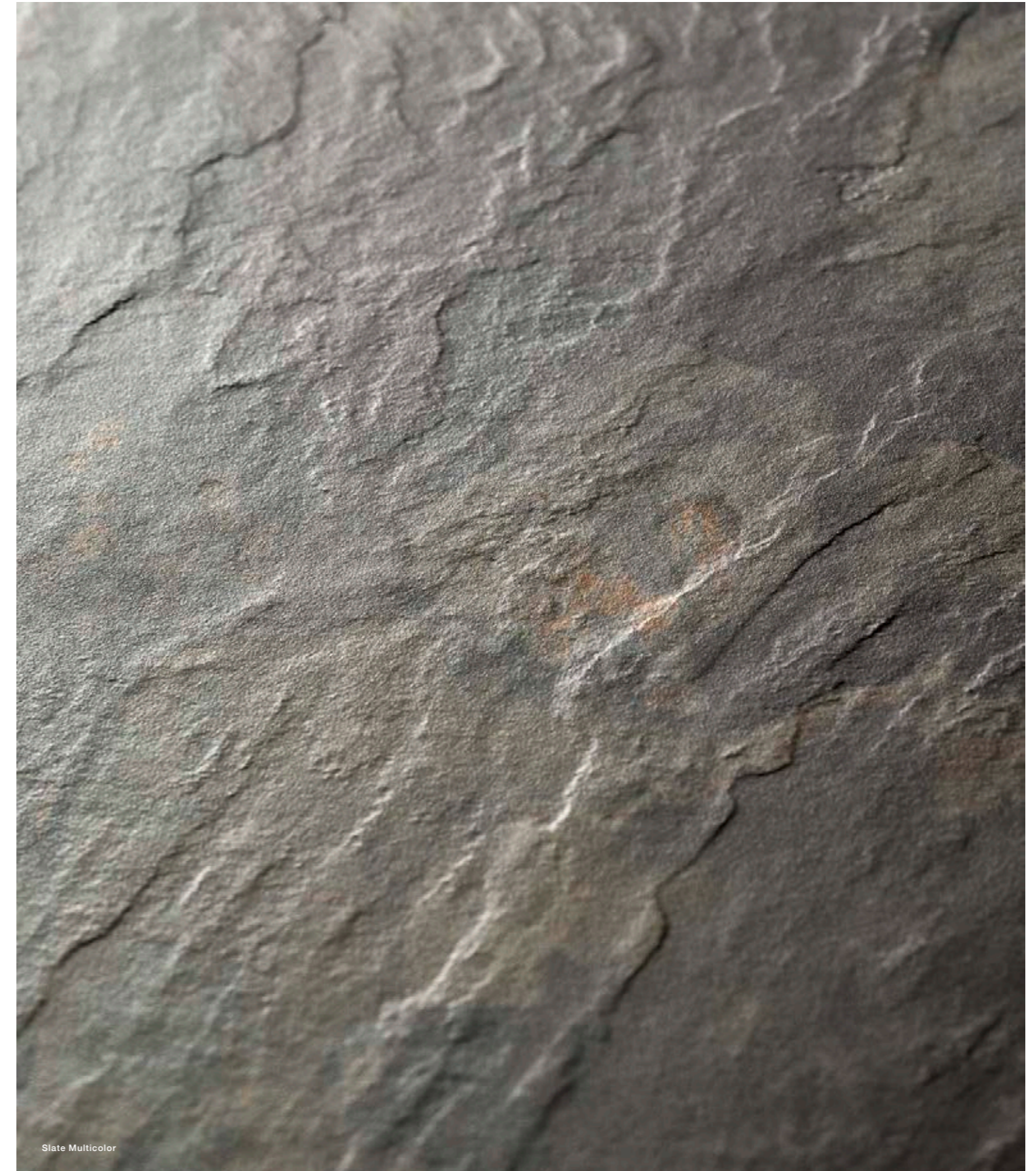

Slate Multicolor

ZOOM

Stones

Stones

Superfícies estruturadas que recriam a essência da pedra natural.
Structured surfaces that recreate the essence of natural stone.
Des surfaces structurées qui recréent l'essence de la pierre naturelle.
Superfícies estruturadas que recrean la esencia de la piedra natural.

Xisto



Xisto Multicolor



Xisto Marfim
Stratus 36 Xisto Marfim

04 cores
colors
couleurs
colors

03 formatos
formats
formats
formats

01 acabamento
finish
finition
acabado



Superbranco

Marfim

Multicolor

Preto



10

Até 10 desenhos
Up to 10 designs
Jusqu'à 10 dessins
Hasta 10 diseños

Xisto Multicolor

GRAPHIC VARIATION

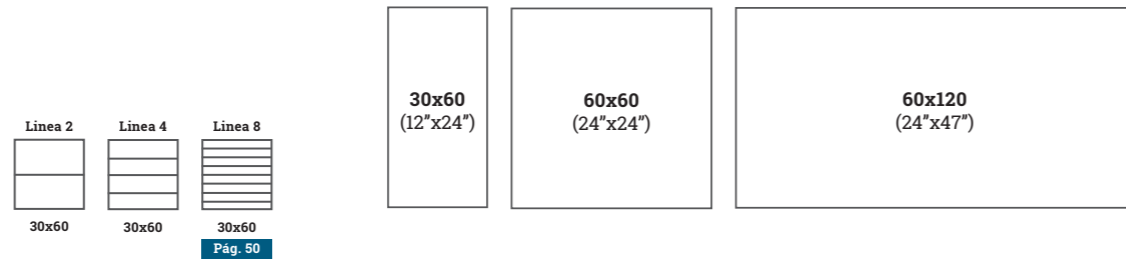

	Peças / Pieces		Caixa / Box			Europaleta / Europallet		
		Espeçura (mm) Thickness (mm)	Nº Peças No Pieces	M² Aprox. No of Sq. M. Approx.	Peso (Kg) Weight Kg	Nº Caixas No Boxes	M² Aprox. No of Sq. M. Approx.	Peso (Kg) Weight (Kg)
30x60 cm	Nat.	± 8,5 ±5%	5	0.90	18.0	48	43.20	885
	Rect.	± 8,5 ±5%	5	0.90	18.0	60	54.00	1 101
60x60 cm	Rect.	± 8,5 ±5%	4	1.44	28.7	36	51.84	1 053
60x120 cm	Rect.	± 9,8 ±5%	2	1.44	33.0	30	43.20	1 011



Xisto Superbranco
Step Silver



XISTO SUPERBRANCO

60x120	RECT	[59,2x118,4x0,98 cm]	P139	V2	3	class 1	≥0,42
30x60	NAT	[...x0,85 cm]	P85	V2	3	class 1	≥0,42
	RECT	[29,6x59,2x0,85 cm]	P95	V2	3	class 1	≥0,42



XISTO SUPERBRANCO

60x60	RECT	[59,2x59,2x0,85 cm]	P111	V2	3	class 1	≥0,42
--------------	------	-----------------------	-------------	----	---	---------	-------



XISTO MULTICOLOR

60x120	RECT	[59,2x118,4x0,98 cm]	P139	V4	3	class 1	≥0,42
30x60	NAT	[...x0,85 cm]	P81	V4	3	class 1	≥0,42
	RECT	[29,6x59,2x0,85 cm]	P91	V4	3	class 1	≥0,42

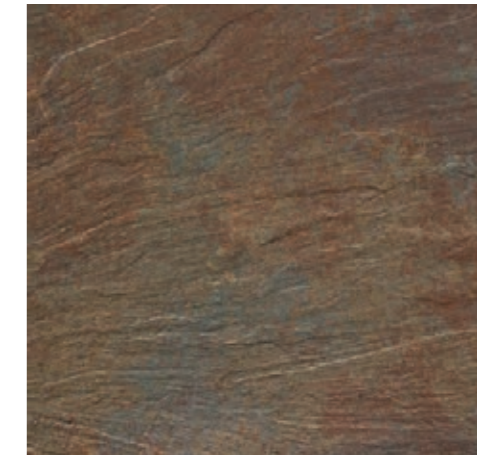

XISTO MULTICOLOR

60x60	RECT	[59,2x59,2x0,85 cm]	P111	V4	3	class 1	≥0,42
--------------	------	-----------------------	-------------	----	---	---------	-------



XISTO MARFIM

60x120	RECT	[59,2x118,4x0,98 cm]	P139	V2	3	class 1	≥0,42
30x60	NAT	[...x0,85 cm]	P85	V2	3	class 1	≥0,42
	RECT	[29,6x59,2x0,85 cm]	P95	V2	3	class 1	≥0,42



XISTO MARFIM

60x60	RECT	[59,2x59,2x0,85 cm]	P111	V2	3	class 1	≥0,42
--------------	------	-----------------------	-------------	----	---	---------	-------

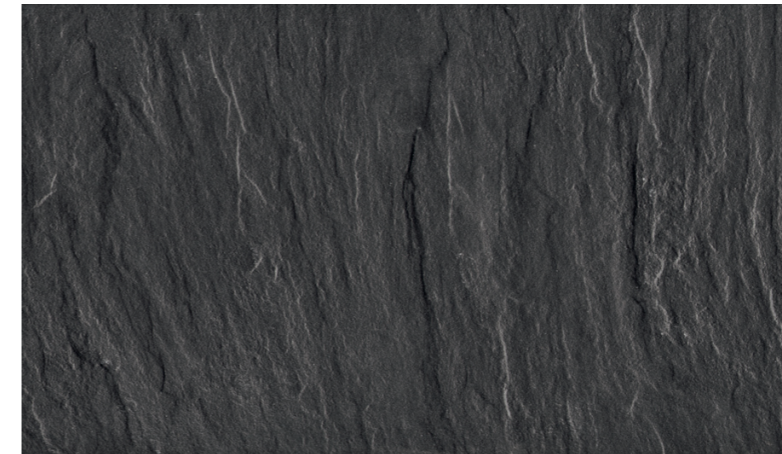

XISTO PRETO

60x120	RECT	[59,2x118,4x0,98 cm]	P139	V2	3	class 1	≥0,42
30x60	NAT	[...x0,85 cm]	P81	V2	3	class 1	≥0,42
	RECT	[29,6x59,2x0,85 cm]	P91	V2	3	class 1	≥0,42



XISTO PRETO

60x60	RECT	[59,2x59,2x0,85 cm]	P111	V2	3	class 1	≥0,42
--------------	------	-----------------------	-------------	----	---	---------	-------

Tendo em vista alcançar um efeito global mais real e harmonioso, são produzidas peças diferentes umas das outras com variações de desenho e/ou cores entre elas.
 For a more genuine and harmonious effect overall, different tiles with design and/or colour variations are produced.
 Afin d'obtenir un effet global plus réel et harmonieux, nos pièces sont différentes les unes des autres avec des variations de dessin et / ou de nuances entre elles.
 Para lograr un efecto global más real y armonioso, se producen piezas diferentes unas de otras con variaciones de diseño y/o color.



STEP SILVER (a)
30x30 P97 / peça_pieza



DUO 36 XISTO MARFIM (a)
30x30 P21 / peça_pieza



STEP GOLD (a)
30x30 P97 / peça_pieza



DUO 36 XISTO PRETO (a)
30x30 P21 / peça_pieza

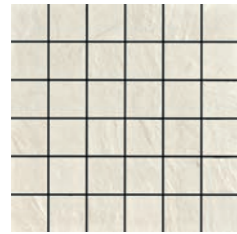

STRATUS 36 XISTO SUPERBRANCO (a) (f)
30x30 P19 / peça_pieza

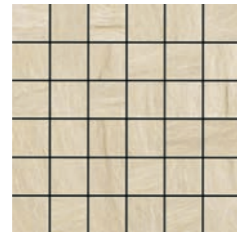

STRATUS 36 XISTO MARFIM (a) (f)
30x30 P19 / peça_pieza

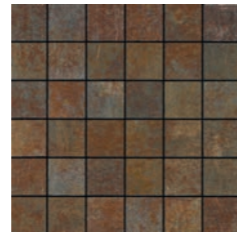

STRATUS 36 XISTO MULTICOLOR (a) (f)
30x30 P19 / peça_pieza



STRATUS 36 XISTO PRETO (a) (f)
30x30 P19 / peça_pieza



STRATUS 9 XISTO SUPERBRANCO (a) (f)
30x30 P19 / peça_pieza



STRATUS 9 XISTO MARFIM (a) (f)
30x30 P19 / peça_pieza



STRATUS 9 XISTO MULTICOLOR (a) (f)
30x30 P19 / peça_pieza



STRATUS 9 XISTO PRETO (a) (f)
30x30 P19 / peça_pieza



DUO 8 XISTO MARFIM (a)
30x30 P21 / peça_pieza



COLUNATTA 2 XISTO PRETO (a)
30x30 P21 / peça_pieza



DUO 8 XISTO PRETO (a)
30x30 P21 / peça_pieza



Xisto Multicolor

ZOOM

DG	PEÇA _ PIECE		RB	PEÇA _ PIECE		DG CF	Rect	DG CF CANTO	Rect
	Nat	Rect		Nat	Rect				
30x30 cm	P08	P10	9,5x30 cm	P07	P08	30x60 cm	P157	30x60 cm	P207
30x60 cm	P12	P18	8x60 cm	P10	P12				
60x60 cm	-	P36	8x120 cm	-	P28				
30x120 cm	-	P97							
60x120 cm	-	P167							

DG CF / DG CF Canto: Peças produzidas sob encomenda.
DG CF / DG CF Canto: Pieces produced on order.
DG CF / DG CF Canto: Pièces produites sur commande.
DG CF / DG CF Canto: Piezas producidas por encargo.

DG CF Canto: Disponível em canto esquerdo e direito.
DG CF Canto: Available in left and right corner.
DG CF Canto: Disponible en angle gauche et droit.
DG CF Canto: Canto izquierdo y derecho disponibles.

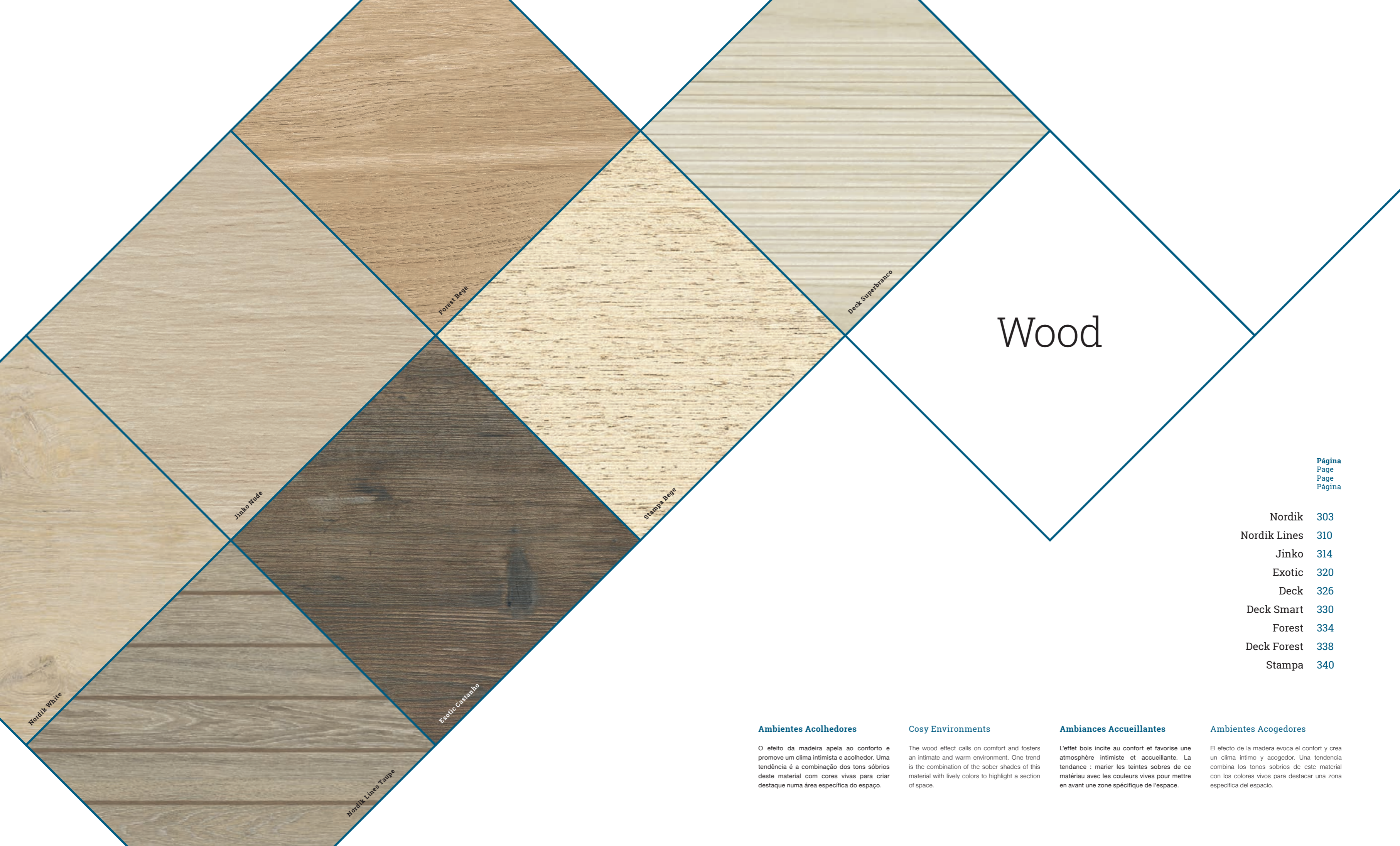

Wood

Página
Page
Page
Página

Nordik	303
Nordik Lines	310
Jinko	314
Exotic	320
Deck	326
Deck Smart	330
Forest	334
Deck Forest	338
Stampa	340

Ambientes Acolhedores

O efeito da madeira apela ao conforto e promove um clima intimista e acolhedor. Uma tendência é a combinação dos tons sóbrios deste material com cores vivas para criar destaque numa área específica do espaço.

Cosy Environments

The wood effect calls on comfort and fosters an intimate and warm environment. One trend is the combination of the sober shades of this material with lively colors to highlight a section of space.

Ambiances Accueillantes

L'effet bois incite au confort et favorise une atmosphère intimiste et accueillante. La tendance : marier les teintes sobres de ce matériau avec les couleurs vives pour mettre en avant une zone spécifique de l'espace.

Ambientes Acogedores

El efecto de la madera evoca el confort y crea un clima íntimo y acogedor. Una tendencia combina los tonos sobrios de este material con los colores vivos para destacar una zona específica del espacio.



A nobreza das madeiras nórdicas reproduzida num novo formato, para criar ambientes sofisticados.
 The nobility of Nordic wood reproduced in a new format for creating sophisticated environments.
 La noblesse des bois nordiques reproduite dans un nouveau format, pour créer des atmosphères sophistiquées.
 La nobleza de las maderas nórdicas reproducida en un nuevo formato, para crear ambientes sofisticados.

Nordik



Viking Nordik Nut
 Statuario White



Nordik Taupe
 Laki Taupe
 MixForms White

04 cores
colors
couleurs
colors

05 formatos
formats
formats
formats

01 acabamento
finish
finition
acabado

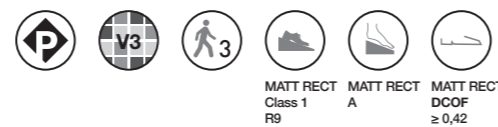

Taupe

White

Cherry

Nut

20

Até 20 desenhos
Up to 20 designs
Jusqu'à 20 dessins
Hasta 20 diseños

Nordik Cherry

GRAPHIC VARIATION

15x120
(6"x47")

19,5x120
(8"x47")

19,5x180
(8"x71")

30x180
(12"x71")

30x120
(12"x47")

Peças / Pieces		Caixa / Box			Europaleta / Europallet			
Formato	Acabamento	Espessura (mm) Thickness (mm)	Nº Peças No Pieces	M² Aprox. No of Sq. M. Approx.	Peso (Kg) Weight Kg	Nº Caixas No Boxes	M² Aprox. No of Sq. M. Approx.	Peso (Kg) Weight (Kg)
15x120 cm	Matt Rect.	≅ 10,5 ±0,5 mm	8	1.44	34.7	18	25.92	646
19,5x120 cm	Matt Rect.	≅ 10,5 ±0,5 mm	6	1.40	33.0	24	33.60	813
19,5x120 cm	Matt Rect. Chevron	≅ 10,5 ±0,5 mm	4	0.78	18.0	16	12.48	308
30x120 cm	Matt Rect.	≅ 10,5 ±0,5 mm	4	1.44	34.7	16	23.04	576
19,5x180 cm	Matt Rect.	≅ 11,2 ±0,5 mm	4	1.40	35.5	32	44.80	1162
30x180 cm	Matt Rect.	≅ 11,2 ±0,5 mm	3	1.62	41.0	20	32.40	848

NEW
FORMATO / FORMAT
180 cm



Nordik White
Nordik Cherry
Baltic Grey



NORDIK TAUPE (*)

Size	Finish	Dimensions	Code	Class	Grade	MOE	MOI
30x180	MATT RECT	[29,6x180,0x1,12 cm]	P127	V3	class 1	A	R9 ≥0,42
19,5x180	MATT RECT	[19,5x180,0x1,12 cm]	P127	V3	class 1	A	R9 ≥0,42
30x120	MATT RECT	[29,6x120,0x1,05 cm]	P94	V3	class 1	A	R9 ≥0,42
19,5x120	MATT RECT	[19,5x120,0x1,05 cm]	P94	V3	class 1	A	R9 ≥0,42
15x120	MATT RECT	[14,7x120,0x1,05 cm]	P94	V3	class 1	A	R9 ≥0,42



CHEVRON LEFT NORDIK TAUPE

19,5x120	MATT RECT	[19,5x120,0x1,05 cm]	P153
----------	-----------	----------------------	------

CHEVRON RIGHT NORDIK TAUPE

19,5x120	MATT RECT	[19,5x120,0x1,05 cm]	P153
----------	-----------	----------------------	------



NORDIK WHITE (*)

Size	Finish	Dimensions	Code	Class	Grade	MOE	MOI
30x180	MATT RECT	[29,6x180,0x1,12 cm]	P127	V3	class 1	A	R9 ≥0,42
19,5x180	MATT RECT	[19,5x180,0x1,12 cm]	P127	V3	class 1	A	R9 ≥0,42
30x120	MATT RECT	[29,6x120,0x1,05 cm]	P94	V3	class 1	A	R9 ≥0,42
19,5x120	MATT RECT	[19,5x120,0x1,05 cm]	P94	V3	class 1	A	R9 ≥0,42
15x120	MATT RECT	[14,7x120,0x1,05 cm]	P94	V3	class 1	A	R9 ≥0,42



CHEVRON LEFT NORDIK WHITE

19,5x120	MATT RECT	[19,5x120,0x1,05 cm]	P153
----------	-----------	----------------------	------

CHEVRON RIGHT NORDIK WHITE

19,5x120	MATT RECT	[19,5x120,0x1,05 cm]	P153
----------	-----------	----------------------	------

Para o assentamento de peças de grande formato, sugerimos a utilização de niveladores para ajudar a posicionar e nivelar a junta entre peças. Estes acessórios plásticos devem ser utilizados após a aplicação da cola.

When laying large format tiles, use levelling spacers to ensure proper installing and levelling of tiles. Use the plastic spacers after the adhesive has been applied.

Pour la pose de pièces de grand format, nous suggérons l'utilisation de croisillons autonivelants pour aider à positionner et à niveler le joint entre les pièces. Ces accessoires en plastique doivent être utilisés après l'application de la colle.

Para la colocación de piezas de gran tamaño, sugerimos utilizar niveladores para ayudar a colocar y nivelar la junta entre piezas. Estos accesorios plásticos deben utilizarse una vez aplicada la cola.



IDEAL PARA PISO RADIANTE
IDEAL FOR UNDERFLOOR HEATING
IDÉAL SUR SOLS CHAUFFANTS
IDEAL PARA SUELO RADIANTE



NORDIK CHERRY (*)

Size	Finish	Dimensions	Code	Class	Grade	MOE	MOI
30x180	MATT RECT	[29,6x180,0x1,12 cm]	P127	V3	class 1	A	R9 ≥0,42
19,5x180	MATT RECT	[19,5x180,0x1,12 cm]	P127	V3	class 1	A	R9 ≥0,42
30x120	MATT RECT	[29,6x120,0x1,05 cm]	P94	V3	class 1	A	R9 ≥0,42
19,5x120	MATT RECT	[19,5x120,0x1,05 cm]	P94	V3	class 1	A	R9 ≥0,42
15x120	MATT RECT	[14,7x120,0x1,05 cm]	P94	V3	class 1	A	R9 ≥0,42



CHEVRON LEFT NORDIK CHERRY

19,5x120	MATT RECT	[19,5x120,0x1,05 cm]	P153
----------	-----------	----------------------	------

CHEVRON RIGHT NORDIK CHERRY

19,5x120	MATT RECT	[19,5x120,0x1,05 cm]	P153
----------	-----------	----------------------	------



NORDIK NUT (*)

Size	Finish	Dimensions	Code	Class	Grade	MOE	MOI
30x180	MATT RECT	[29,6x180,0x1,12 cm]	P127	V3	class 1	A	R9 ≥0,42
19,5x180	MATT RECT	[19,5x180,0x1,12 cm]	P127	V3	class 1	A	R9 ≥0,42
30x120	MATT RECT	[29,6x120,0x1,05 cm]	P94	V3	class 1	A	R9 ≥0,42
19,5x120	MATT RECT	[19,5x120,0x1,05 cm]	P94	V3	class 1	A	R9 ≥0,42
15x120	MATT RECT	[14,7x120,0x1,05 cm]	P94	V3	class 1	A	R9 ≥0,42



CHEVRON LEFT NORDIK NUT

19,5x120	MATT RECT	[19,5x120,0x1,05 cm]	P153
----------	-----------	----------------------	------

CHEVRON RIGHT NORDIK NUT

19,5x120	MATT RECT	[19,5x120,0x1,05 cm]	P153
----------	-----------	----------------------	------

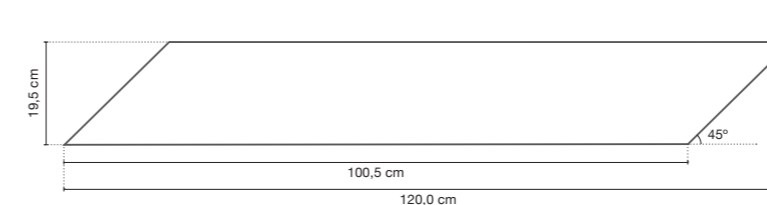

CHEVRON 19,5x120 cm

[1m² = 5 peças]

(*) Dada a dimensão do produto e devido às tolerâncias de planaridade permitidas (de acordo com as normas internacionais), recomendamos a aplicação em paralelo e, no caso de aplicação em contrafiada, no máximo, a 1/4 da peça.

(*) Given the product's size and due to the planar tolerances allowed (in accordance with international standards), we recommend the parallel application and, if applied interrupting the joints, we recommend a maximum 1/4 application from the piece.

(*) Étant donnée la dimension du produit et en raison des tolérances de planitude permises (conformément aux normes internationales), nous recommandons l'application en parallèle et, dans le cas d'application en contre-joint, au maximum 1/4 de la pièce.

(*) Dada la dimensión del producto y debido a las tolerancias de planaridad permitidas (de acuerdo con las normas internacionales), recomendamos la aplicación en paralelo y, en el caso de aplicación en asiento, como máximo, a 1/4 de la pieza.



VIKING NORDIK TAUPE (b) (f)
19,5x108,5 MATT RECT [19,5x108,5x1,05 cm] P32 / peça_piece



VIKING NORDIK WHITE (b) (f)
19,5x108,5 MATT RECT [19,5x108,5x1,05 cm] P32 / peça_piece



VIKING NORDIK CHERRY (b) (f)
19,5x108,5 MATT RECT [19,5x108,5x1,05 cm] P32 / peça_piece



VIKING NORDIK NUT (b) (f)
19,5x108,5 MATT RECT [19,5x108,5x1,05 cm] P32 / peça_piece

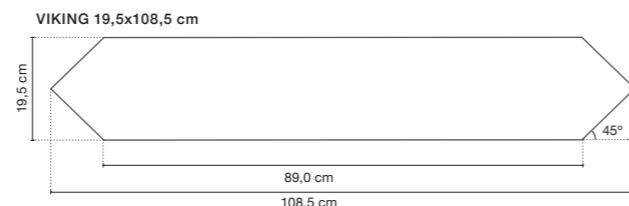

APLICAÇÃO: · APPLICATION:
APLICACIÓN: · APLICACIÓN:

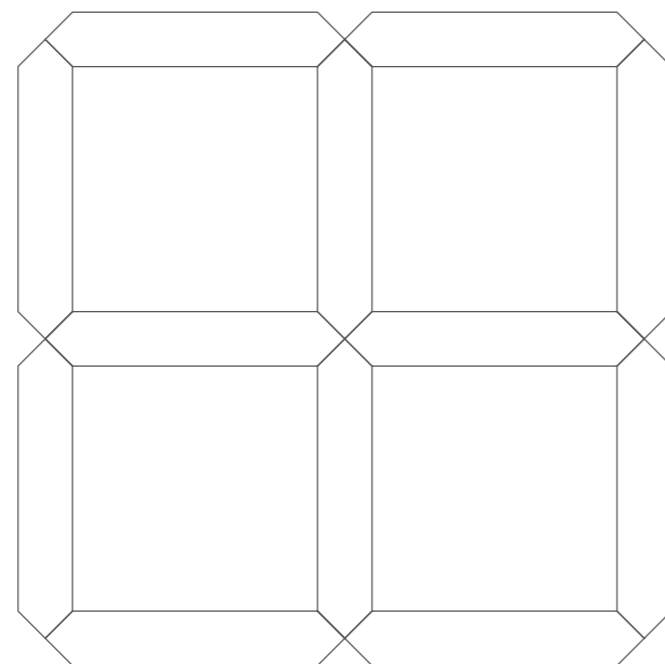

LOKI TAUPE (a) (b) (f)
19,5x19,5 [19,5x19,5x1,05 cm] P15 / peça_piece



LOKI WHITE (a) (b) (f)
19,5x19,5 [19,5x19,5x1,05 cm] P15 / peça_piece



LOKI CHERRY (a) (b) (f)
19,5x19,5 [19,5x19,5x1,05 cm] P15 / peça_piece



LOKI NUT (a) (b) (f)
19,5x19,5 [19,5x19,5x1,05 cm] P15 / peça_piece



ODIN TAUPE (a) (b) (f)
30x30 [29,6x29,6x1,05 cm] P19 / peça_piece



ODIN WHITE (a) (b) (f)
30x30 [29,6x29,6x1,05 cm] P19 / peça_piece



ODIN CHERRY (a) (b) (f)
30x30 [29,6x29,6x1,05 cm] P19 / peça_piece



ODIN NUT (a) (b) (f)
30x30 [29,6x29,6x1,05 cm] P19 / peça_piece



Nordik White

ZOOM



Nordik Taupe

ZOOM

DG	PEÇA_PIECE	RB	PEÇA_PIECE	DG CF	PEÇA_PIECE	DG CF CANTO	PEÇA_PIECE
30x120 cm	Matt Rect P97	8x60 cm	Matt Rect P16	30x120 cm	Matt Rect P175	30x120 cm	Matt Rect P247
		8x120 cm	P28				

DG CF / DG CF Canto: Peças produzidas sob encomenda.
DG CF / DG CF Canto: Pièces produites sur commande.
DG CF / DG CF Canto: Piezas producidas por encargo.

DG CF Canto: Disponível em canto esquerdo e direito.
DG CF Canto: Available in left and right corner.
DG CF Canto: Disponible en angle gauche et droit.
DG CF Canto: Canto izquierdo y derecho disponibles.



A nobreza das madeiras nórdicas enriquecida com linhas em relevo que dão um charme intemporal aos espaços interiores.
 The nobility of Nordic wood enriched with contour lines that lend timeless charm to interiors.
 La noblesse des bois nordiques enrichie de lignes en relief qui confèrent un charme intemporel aux espaces intérieurs.
 La nobleza de las maderas nórdicas enriquecida con líneas en relieve que aportan un encanto atemporal a los espacios interiores.



Nordik Lines



Nordik Lines Nut
 Nordik Nut



Nordik Lines Cherry
 Nordik Cherry

- 04** cores
couleurs
colors
- 01** formato
format
formato
- 01** acabamento
finish
finition
acabado



Wood

Wood

30x90
(12"x35")

Peças / Pieces		Caixa / Box			Europaleta / Europallet		
Espeçura (mm) Thickness (mm)	Nº Peças No Pieces	M² Aprox. No of Sq. M. Approx.	Peso (Kg) Weight Kg	Nº Caixas No Boxes	M² Aprox. No of Sq. M. Approx.	Peso (Kg) Weight (Kg)	
30x90 cm Rect.	± 12,3 ± 0,5 mm	4	1,08	22,0	40	43,2	901

Wood

Wood

30x90 RECT [29,6x88,8x1,23 cm] P95

NORDIK LINES TAUPE

30x90 RECT [29,6x88,8x1,23 cm] P95

NORDIK LINES WHITE

30x90 RECT [29,6x88,8x1,23 cm] P95

NORDIK LINES CHERRY

30x90 RECT [29,6x88,8x1,23 cm] P95

NORDIK LINES NUT

30x90 RECT [29,6x88,8x1,23 cm] P95

Dado o efeito deste produto, as peças devem ser sempre aplicadas no mesmo sentido.
Given the effect of the product, tiles must always be laid out facing same direction.
En raison de l'effet de ce produit, les carreaux doivent toujours être posés dans le même sens.
Dado el efecto de este producto, las piezas deben aplicarse siempre en el mismo sentido.

Uma reinterpretação da madeira com um relevo suave que recria a textura natural.
Reinterpretation of wood with a smooth relief that recreates the natural texture.
Une réinterprétation du bois avec un doux relief qui recrée la texture naturelle.
Una reinterpretación de la madera con un relieve suave que recrea la textura natural.

Jinko



Jinko Ginger
Jinko Âmbar
Stratus 36 Globe Fog



Jinko Âmbar
Jinko Nude
Venezia Bianco

06 cores
colors
couleurs
colores

03 formatos
formats
formats
formatos

01 acabamento
finish
finition
acabado

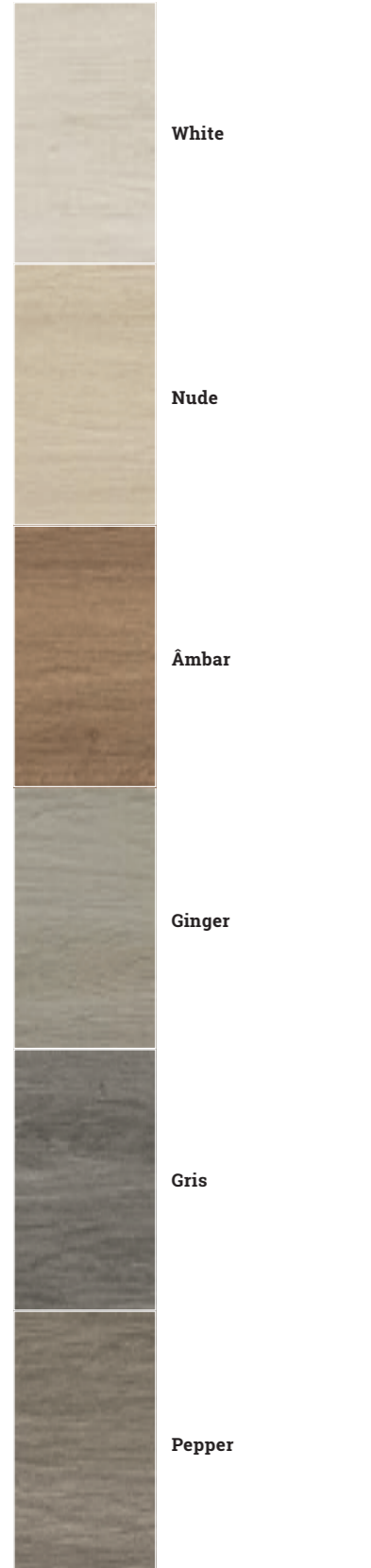
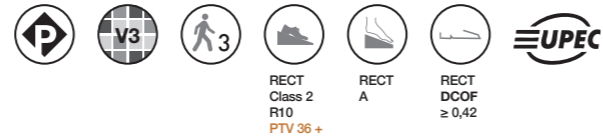

10
Até 10 desenhos
Up to 10 designs
Jusqu'à 10 dessins
Hasta 10 diseños

GRAPHIC VARIATION

15x120
(6"x47")

19,5x120
(8"x47")

30x120
(12"x47")

Peças / Pieces		Caixa / Box			Europaleta / Europallet		
	Espessura (mm) Thickness (mm)	Nº Peças No Pieces	M² Aprox. No of Sq. M. Approx.	Peso (Kg) Weight Kg	Nº Caixas No Boxes	M² Aprox. No of Sq. M. Approx.	Peso (Kg) Weight (Kg)
15x120 cm	Rect. 10,5 ±0,5 mm	8	1.44	34.7	18	25.92	646
19,5x120 cm	Rect. 10,5 ±0,5 mm	6	1.40	33.0	24	33.60	813
30x120 cm	Rect. 10,5 ±0,5 mm	4	1.44	34.7	16	23.04	576



IDEAL PARA PISO RADIANTE
IDEAL FOR UNDERFLOOR HEATING
IDÉAL SUR SOLS CHAUFFANTS
IDEAL PARA SUELO RADIANTE



JINKO WHITE

30x120	RECT	[29,6x120,0x1,05 cm]	P94	V3	class 2	A	R10	36+	≥0,42	U4P3E3C2
19,5x120	RECT	[19,5x120,0x1,05 cm]	P94	V3	class 2	A	R10	36+	≥0,42	U4P2E3C2
15x120	RECT	[14,7x120,0x1,05 cm]	P94	V3	class 2	A	R10	36+	≥0,42	-



JINKO NUDE

30x120	RECT	[29,6x120,0x1,05 cm]	P94	V3	class 2	A	R10	36+	≥0,42	U4P3E3C2
19,5x120	RECT	[19,5x120,0x1,05 cm]	P94	V3	class 2	A	R10	36+	≥0,42	U4P2E3C2
15x120	RECT	[14,7x120,0x1,05 cm]	P94	V3	class 2	A	R10	36+	≥0,42	-



JINKO ÂMBAR

30x120	RECT	[29,6x120,0x1,05 cm]	P94	V3	class 2	A	R10	36+	≥0,42	U4P3E3C2
19,5x120	RECT	[19,5x120,0x1,05 cm]	P94	V3	class 2	A	R10	36+	≥0,42	U4P2E3C2
15x120	RECT	[14,7x120,0x1,05 cm]	P94	V3	class 2	A	R10	36+	≥0,42	-



JINKO GINGER

30x120	RECT	[29,6x120,0x1,05 cm]	P94	V3	class 2	A	R10	36+	≥0,42	U4P3E3C2
19,5x120	RECT	[19,5x120,0x1,05 cm]	P94	V3	class 2	A	R10	36+	≥0,42	U4P2E3C2
15x120	RECT	[14,7x120,0x1,05 cm]	P94	V3	class 2	A	R10	36+	≥0,42	-

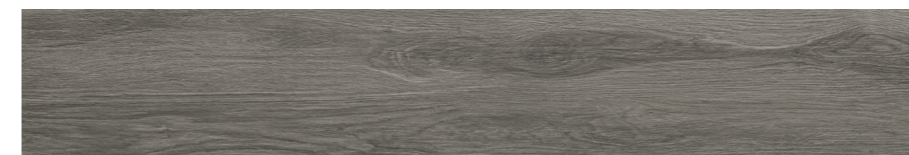

JINKO GRIS

30x120	RECT	[29,6x120,0x1,05 cm]	P94	V3	class 2	A	R10	36+	≥0,42	U4P3E3C2
19,5x120	RECT	[19,5x120,0x1,05 cm]	P94	V3	class 2	A	R10	36+	≥0,42	U4P2E3C2
15x120	RECT	[14,7x120,0x1,05 cm]	P94	V3	class 2	A	R10	36+	≥0,42	-

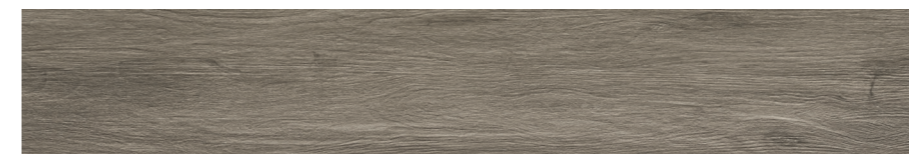

JINKO PEPPER

30x120	RECT	[29,6x120,0x1,05 cm]	P94	V3	class 2	A	R10	36+	≥0,42	U4P3E3C2
19,5x120	RECT	[19,5x120,0x1,05 cm]	P94	V3	class 2	A	R10	36+	≥0,42	U4P2E3C2
15x120	RECT	[14,7x120,0x1,05 cm]	P94	V3	class 2	A	R10	36+	≥0,42	-

Dada a dimensão do produto e devido às tolerâncias de planaridade permitidas (de acordo com as normas internacionais), recomendamos a aplicação em paralelo e, no caso de aplicação em contrafiada, no máximo, a 1/4 da peça.

Given the product's size and due to the planar tolerances allowed (in accordance with international standards), we recommend the parallel application and, if applied interrupting the joints, we recommend a maximum 1/4 application from the piece.

Étant donnée la dimension du produit et en raison des tolérances de planitude permises (conformément aux normes internationales), nous recommandons l'application en parallèle et, dans le cas d'application en contre-fil, au maximum d'1/4 de la pièce.

Dada la dimensión del producto y debido a las tolerancias de planaridad permitidas (de acuerdo con las normas internacionales), recomendamos la aplicación en paralelo y, en el caso de aplicación en asiento, como máximo, a 1/4 de la pieza.



Jinko Nude



Jinko Ginger

ZOOM

	PEÇA _ PIECE		PEÇA _ PIECE		PEÇA _ PIECE		PEÇA _ PIECE
DG	Rect	RB	Rect	DG CF	Rect	DG CF CANTO	Rect
30x120 cm	P97	8x60 cm	P16	30x120 cm	P175	30x120 cm	P247
		8x120 cm	P28				

DG CF / DG CF Canto: Peças produzidas sob encomenda.
 DG CF / DG CF Canto: Pieces produced on order.
 DG CF / DG CF Canto: Pièces produites sur commande.
 DG CF / DG CF Canto: Piezas producidas por encargo.

DG CF Canto: Disponível em canto esquerdo e direito.
 DG CF Canto: Available in left and right corner.
 DG CF Canto: Disponible en angle gauche et droit.
 DG CF Canto: Canto izquierdo y derecho disponibles.



Jinko White
 Jinko Pepper

O efeito da madeira envelhecida para espaços com carácter.
The effect of aged wood for spaces with character.
L'effet du bois vieilli pour des espaces avec du cachet.
El efecto de la madera envejecida para espacios con carácter.

Exotic



Exotic Branco
Globe Branco



Exotic Castanho
Exotic Âmbar

- 04** cores
colors
couleurs
colores
- 03** formatos
formats
formats
formatos
- 01** acabamento
finish
 finition
 acabado

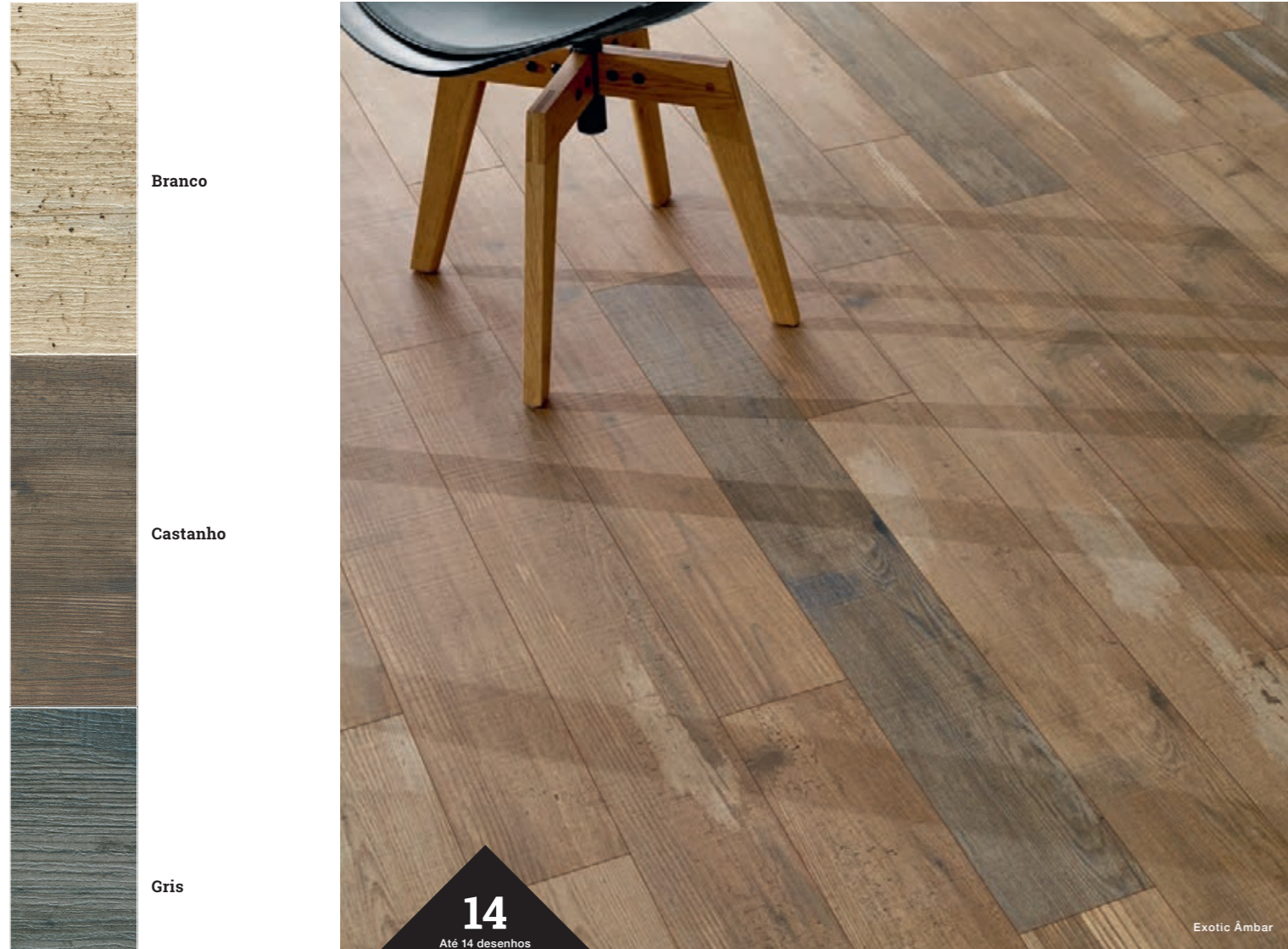
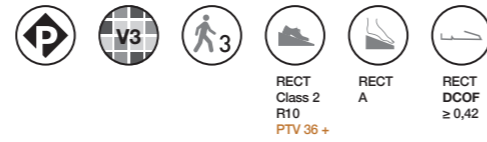

14
Até 14 desenhos
Up to 14 designs
Jusqu'à 14 dessins
Hasta 14 diseños

GRAPHIC VARIATION

15x120 (6"x47")
19,5x120 (8"x47")
30x120 (12"x47")

Peças / Pieces		Caixa / Box			Europaleta / Europallet			
	Espessura (mm) Thickness (mm)	Nº Peças No Pieces	M² Aprox. No of Sq. M. Approx.	Peso (Kg) Weight Kg	Nº Caixas No Boxes	M² Aprox. No of Sq. M. Approx.	Peso (Kg) Weight (Kg)	
15x120 cm	Rect.	± 9,8 ±5%	8	1.44	34.7	18	25.92	646
19,5x120 cm	Rect.	± 9,8 ±5%	6	1.40	33.0	24	33.60	813
30x120 cm	Rect.	± 9,8 ±5%	4	1.44	34.7	16	23.04	576



IDEAL PARA PISO RADIANTE
IDEAL FOR UNDERFLOOR HEATING
IDÉAL SUR SOLS CHAUFFANTS
IDEAL PARA SUELO RADIANTE



EXOTIC BRANCO

30x120	RECT	[29,6x120,0x0,98 cm]	P109	V3	3	class 2	A	R10	36+	≥0,42
19,5x120	RECT	[19,5x120,0x0,98 cm]	P109	V3	3	class 2	A	R10	36+	≥0,42
15x120	RECT	[14,7x120,0x0,98 cm]	P109	V3	3	class 2	A	R10	36+	≥0,42



EXOTIC CASTANHO

30x120	RECT	[29,6x120,0x0,98 cm]	P109	V3	3	class 2	A	R10	36+	≥0,42
19,5x120	RECT	[19,5x120,0x0,98 cm]	P109	V3	3	class 2	A	R10	36+	≥0,42
15x120	RECT	[14,7x120,0x0,98 cm]	P109	V3	3	class 2	A	R10	36+	≥0,42



EXOTIC GRIS

30x120	RECT	[29,6x120,0x0,98 cm]	P109	V3	3	class 2	A	R10	36+	≥0,42
19,5x120	RECT	[19,5x120,0x0,98 cm]	P109	V3	3	class 2	A	R10	36+	≥0,42
15x120	RECT	[14,7x120,0x0,98 cm]	P109	V3	3	class 2	A	R10	36+	≥0,42



EXOTIC ÂMBAR

30x120	RECT	[29,6x120,0x0,98 cm]	P109	V3	3	class 2	A	R10	36+	≥0,42
19,5x120	RECT	[19,5x120,0x0,98 cm]	P109	V3	3	class 2	A	R10	36+	≥0,42
15x120	RECT	[14,7x120,0x0,98 cm]	P109	V3	3	class 2	A	R10	36+	≥0,42



STENCIL ÂMBAR (b)

19,5x120	RECT	[19,5x120,0x0,98 cm]	P40 / peça_piece	
----------	------	----------------------	------------------	--

Dada a dimensão do produto e devido às tolerâncias de planaridade permitidas (de acordo com as normas internacionais), recomendamos a aplicação em paralelo e, no caso de aplicação em contrafiada, no máximo, a 1/4 da peça.
Given the product's size and due to the planar tolerances allowed (in accordance with international standards), we recommend the parallel application and, if applied interrupting the joints, we recommend a maximum 1/4 application from the piece.
Étant donnée la dimension du produit et en raison des tolérances de planitude permises (conformément aux normes internationales), nous recommandons l'application en parallèle et, dans le cas d'application en contre-fil, au maximum d'1/4 de la pièce.
Dada la dimensión del producto y debido a las tolerancias de planaridad permitidas (de acuerdo con las normas internacionales), recomendamos la aplicación en paralelo y, en el caso de aplicación en asiento, como máximo, a 1/4 de la pieza.

- (b) Existem várias peças diferentes, de acordo com o desenho do decorado, que devem ser aplicadas alternadamente, de modo a obter-se uma solução mais rica e variada.
- (b) There are different pieces, matching the design of the decorated tiles, which should be applied alternately in order to obtain a richer and more varied decoration.
- (b) Différentes pièces correspondent au dessin du décor. Il convient de les appliquer de façon alternée pour obtenir une disposition plus riche et plus variée.
- (b) Existen diversas piezas diferentes, de acuerdo con el diseño del decorado, que deben aplicarse de forma alterna, con el fin de obtener una solución más y variada.



Wood

Wood

ZOOM

PEÇA _ PIECE		PEÇA _ PIECE		PEÇA _ PIECE		PEÇA _ PIECE	
DG	Rect	RB	Rect	DG CF	Rect	DG CF CANTO	Rect
30x120 cm	P97	8x60 cm	P16	30x120 cm	P175	30x120 cm	P247
		8x120 cm	P28				

DG CF / DG CF Canto: Peças produzidas sob encomenda.
 DG CF / DG CF Canto: Pieces produced on order.
 DG CF / DG CF Canto: Pièces produites sur commande.
 DG CF / DG CF Canto: Piezas producidas por encargo.

DG CF Canto: Disponível em canto esquerdo e direito.
 DG CF Canto: Available in left and right corner.
 DG CF Canto: Disponible en angle gauche et droit.
 DG CF Canto: Canto izquierdo y derecho disponibles.

Deck cerâmico para espaços exteriores.
Ceramic deck for outdoor spaces.
Deck en céramique pour les espaces extérieurs.
Terraza cerámica para espacios exteriores.

Deck



Chevron Nordik White
Deck Wengé



Deck Superbranco

Deck

05 cores
colors
couleurs
colores

01 formato
format
format
formato

01 acabamento
finish
finition
acabado

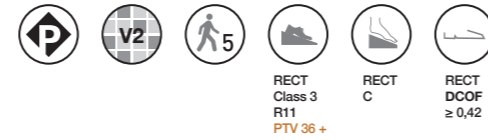

Superbranco

Wengé

Gris

Teca

Ipê

Deck Gris
Deck Wengé

GRAPHIC VARIATION

15x120
(6"x47")

Peças / Pieces		Caixa / Box			Europaleta / Europallet			
	Espessura (mm) Thickness (mm)	Nº Peças No Pieces	M² Aprox. No of Sq. M. Approx.	Peso (Kg) Weight Kg	Nº Caixas No Boxes	M² Aprox. No of Sq. M. Approx.	Peso (Kg) Weight (Kg)	
15x120 cm	Rect.	± 0,8 ±5%	8	1.44	34.7	18	25.92	646

Deck



DECK SUPERBRANCO

15x120	RECT	[14,7x120,0x0,98 cm]	P123	V2	5	class 3	C	R11	36+	≥0,42
--------	------	----------------------	------	----	---	---------	---	-----	-----	-------



DECK WENGÉ

15x120	RECT	[14,7x120,0x0,98 cm]	P123	V2	5	class 3	C	R11	36+	≥0,42
--------	------	----------------------	------	----	---	---------	---	-----	-----	-------



DECK GRIS

15x120	RECT	[14,7x120,0x0,98 cm]	P113	V2	5	class 3	C	R11	36+	≥0,42
--------	------	----------------------	------	----	---	---------	---	-----	-----	-------



DECK TECA

15x120	RECT	[14,7x120,0x0,98 cm]	P113	V2	5	class 3	C	R11	36+	≥0,42
--------	------	----------------------	------	----	---	---------	---	-----	-----	-------



DECK IPÊ

15x120	RECT	[14,7x120,0x0,98 cm]	P123	V2	5	class 3	C	R11	36+	≥0,42
--------	------	----------------------	------	----	---	---------	---	-----	-----	-------

DECK: Produtos que minimizam o risco de deslizamento.
 DECK: Products that minimize the risk of slipping.
 DECK: Produits qui réduisent le risque de glissement.
 DECK: Productos que minimizan el riesgo de deslizamiento.

Dada a dimensão do produto e devido às tolerâncias de planaridade permitidas (de acordo com as normas internacionais), recomendamos a aplicação em paralelo e, no caso de aplicação em contrafiada, no máximo, a 1/4 da peça.
 Given the product's size and due to the planar tolerances allowed (in accordance with international standards), we recommend the parallel application and, if applied interrupting the joints, we recommend a maximum 1/4 application from the piece.
 Étant donnée la dimension du produit et en raison des tolérances de planitude permises (conformément aux normes internationales), nous recommandons l'application en parallèle et, dans le cas d'application en contre-fil, au maximum d'1/4 de la pièce.
 Dada la dimensión del producto y debido a las tolerancias de planaridad permitidas (de acuerdo con las normas internacionales), recomendamos la aplicación en paralelo y, en el caso de aplicación en asiento, como máximo, a 1/4 de la pieza.

Ao aplicar as peças na mesma direção, o ligeiro desalinhamento da parte lisa e/ou das riscas é uma característica intrínseca ao produto. Recomendamos a utilização de junta de, aproximadamente, 3 mm.
 When applying pieces in the same direction, the slight deviation of the flat part and/or stripes is a characteristic intrinsic to the product. We recommend the use of joint of approximately 3 mm.
 Lors de la pose des pièces dans le même sens, le léger décalage de l'alignement de la partie lisse et/ou des rayures est une caractéristique intrinsèque du produit. Nous recommandons l'utilisation d'un joint d'environ 3 mm.
 Al aplicar las piezas en la misma dirección, la ligera desalineación de la parte lisa y/o de las rayas es una característica intrínseca al producto. Le recomendamos el uso de una junta de, aproximadamente, 3 mm.

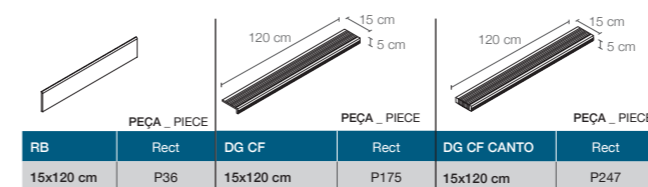

DG CF / DG CF Canto: Peças produzidas sob encomenda.
 DG CF / DG CF Canto: Pieces produced on order.
 DG CF / DG CF Canto: Pièces produites sur commande.
 DG CF / DG CF Canto: Piezas producidas por encargo.

DG CF Canto: Disponível em canto esquerdo e direito.
 DG CF Canto: Available in left and right corner.
 DG CF Canto: Disponible en angle gauche et droit.
 DG CF Canto: Canto izquierdo y derecho disponibles.

Deck cerâmico em pavimento sobrelevado.
Ceramic deck on raised floor.
Deck céramique en plancher surélevé.
Deck cerâmico en suelos elevados.

Deck Smart



Deck Smart Teca

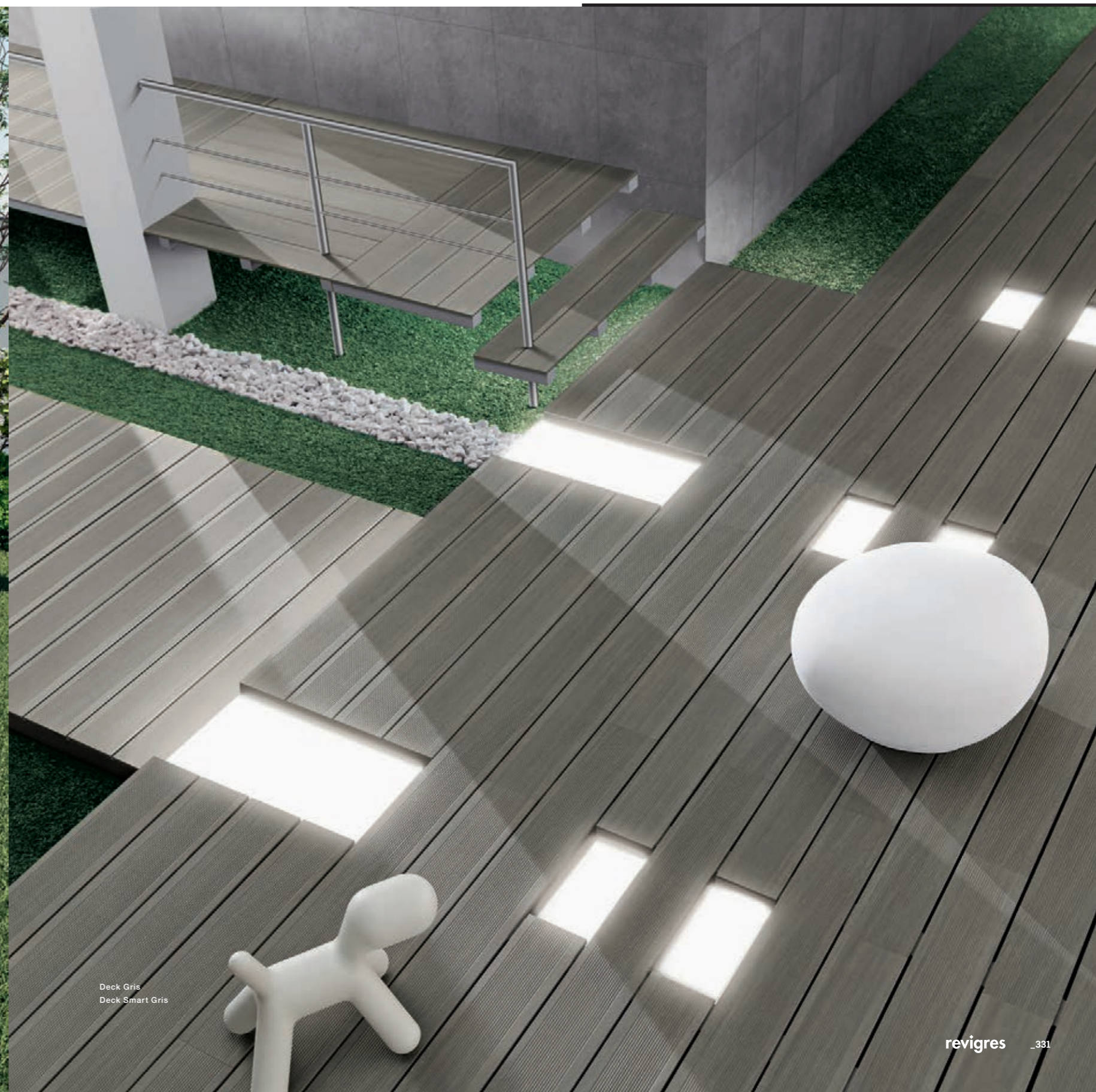

Deck Gris
Deck Smart Gris

05 cores
couleurs
colores

01 formato
format
formato

01 acabamento
finish
finition
acabado

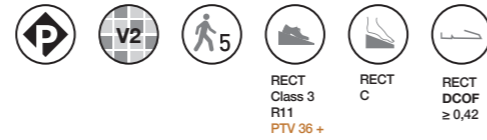

Instalação: consulte a página 412 deste catálogo.
Installation: see page 412 of this catalogue.
Installation : veuillez consulter la page 412 de ce catalogue.
Instalación: consulte la página 412 de este catálogo.

15x120
(6"x47")

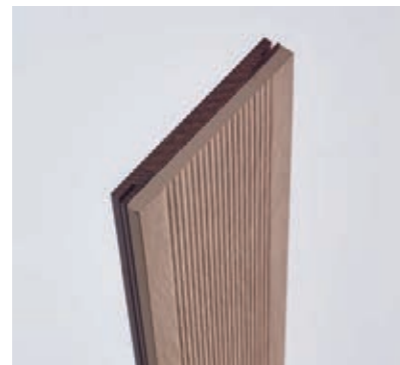

Peça cerâmica (espessura: 0,98 cm) sobre um composto.
Espessura total: ± 2,50 cm
Ceramic piece (thickness : 0,98 cm) on a compound.
Total thickness: ± 2,50 cm
Pièce céramique (épaisseur : 0,98 cm) sur un composite.
Épaisseur totale: ± 2,50 cm
Pieza cerámica (Espesor: 0,98 cm) sobre un compuesto.
Espesor total: ± 2,50 cm

Deck Smart:
Componentes_Components_Composants_Componentes:

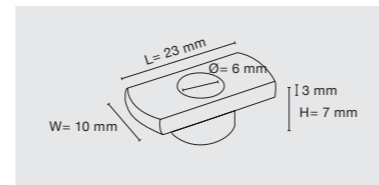

Lingueta de fixação (fornecida na embalagem do material cerâmico: 15 unidades por caixa)
Anchoring bolt (supplied with the ceramic pieces: 15 units per box)
Languette de fixation (fournie dans l'emballage du matériau céramique: 15 unités par boîte)
Lengueta de fijación (se suministra en el embalaje del material cerámico: 15 unidades/caja)

Peças_Pieces	Caixa_Box			Europaleta_Europallet			
	Espeçura (mm) Thickness (mm)	Nº Peças No Pieces	M² Aprox. No of Sq. M. Approx.	Peso (Kg) Weight Kg	Nº Caixas No Boxes	M² Aprox. No of Sq. M. Approx.	Peso (Kg) Weight (Kg)
15x120 cm Rect.	± 25 ± 0,5mm	4	0.72	21.9	18	12.96	430



DECK SMART SUPERBRANCO

15x120 RECT [14,7x120,0x2,50 cm] P245 V2 5 class 3 C R11 36* ≥0,42



DECK SMART WENGÉ

15x120 RECT [14,7x120,0x2,50 cm] P245 V2 5 class 3 C R11 36* ≥0,42



DECK SMART GRIS

15x120 RECT [14,7x120,0x2,50 cm] P235 V2 5 class 3 C R11 36* ≥0,42



DECK SMART TECA

15x120 RECT [14,7x120,0x2,50 cm] P235 V2 5 class 3 C R11 36* ≥0,42

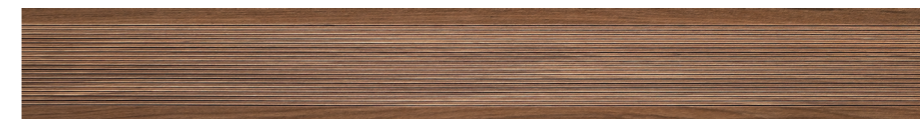

DECK SMART IPÊ

15x120 RECT [14,7x120,0x2,50 cm] P245 V2 5 class 3 C R11 36* ≥0,42

DECK: Produtos que minimizam o risco de deslizamento.
DECK: Products that minimize the risk of slipping.
DECK: Produits qui réduisent le risque de glissement.
DECK: Productos que minimizan el riesgo de deslizamiento.

Deck cerâmico de fácil encaixe adequado para aplicação em piso sobrelevado. O ligeiro desalinhamento da parte lisa e/ou das riscas é uma característica intrínseca ao produto.
Ceramic deck easy to install suitable for raised floors. The slight deviation of the flat part and /or stripes is a characteristic intrinsic to the product.
Deck céramique à emboîtement facile approprié pour les applications sur planchers surélevés. Le léger décalage de l'alignement de la partie lisse et /ou des rayures est une caractéristique intrinsèque du produit.
Deck cerámico de fácil colocación, adecuado para su aplicación en suelo elevado. La ligera desalineación de la parte lisa y/o de las rayas es una característica intrínseca al producto.

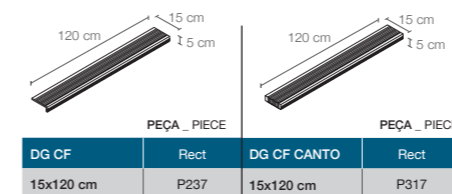

DG CF / DG CF Canto: Peças produzidas sob encomenda.
DG CF / DG CF Canto: Pieces produced on order.
DG CF / DG CF Canto: Pièces produites sur commande.
DG CF / DG CF Canto: Piezas producidas por encargo.

DG CF Canto: Disponível em canto esquerdo e direito.
DG CF Canto: Available in left and right corner.
DG CF Canto: Disponible en angle gauche et droit.
DG CF Canto: Canto izquierdo y derecho disponibles.

Os veios das madeiras naturais combinados com a durabilidade da cerâmica.
The vein patterns of natural wood combined with the longevity of ceramics.
Le grain caractéristique des bois naturels associé à la durabilité de la céramique.
Las vetas de las maderas naturales combinadas con la durabilidad de la cerámica.

Forest



Forest White
Antislip Forest White
Nimbus Marfim
Solids Mix Gris



Impressions Mix Bege
Forest Bege
Antislip Forest Bege

06

cores
colors
couleurs
colores

01

formato
format
format
formato

02

acabamentos
finishes
finitions
acabados



NAT
Class 1
R9

ANTISLIP
Class 3
R11

NAT
A

ANTISLIP
C



19

Até 19 desenhos
Up to 19 designs
Jusqu'à 19 dessins
Hasta 19 diseños

Forest Nude

GRAPHIC VARIATION

15x75
(6"x30")

Peças / Pieces		Caixa / Box			Europaleta / Europallet			
	Espeçura (mm) Thickness (mm)	Nº Peças No Pieces	M² Aprox. No of Sq. M. Approx.	Peso (Kg) Weight Kg	Nº Caixas No Boxes	M² Aprox. No of Sq. M. Approx.	Peso (Kg) Weight (Kg)	
15x75 cm	Nat.	± 0,5 ±5%	8	0.9	17.5	64	57.6	1 141



FOREST BEGE ****
15x75 NAT [...]x0,85 cm] P70 V3 4 class 1 A R9 U3P3E3C2

ANTISLIP FOREST BEGE
15x75 NAT [...]x0,85 cm] P73 V3 4 class 3 C R11



FOREST CHERRY ****
15x75 NAT [...]x0,85 cm] P70 V3 4 class 1 A R9 U3P3E3C2

ANTISLIP FOREST CHERRY
15x75 NAT [...]x0,85 cm] P73 V3 4 class 3 C R11



FOREST NUDE ****
15x75 NAT [...]x0,85 cm] P70 V3 4 class 1 A R9 U3P3E3C2

ANTISLIP FOREST NUDE
15x75 NAT [...]x0,85 cm] P73 V3 4 class 3 C R11



FOREST WHITE ****
15x75 NAT [...]x0,85 cm] P70 V3 4 class 1 A R9 U3P3E3C2

ANTISLIP FOREST WHITE
15x75 NAT [...]x0,85 cm] P73 V3 4 class 3 C R11



FOREST GRIS ****
15x75 NAT [...]x0,85 cm] P70 V3 4 class 1 A R9 U3P3E3C2

ANTISLIP FOREST GRIS
15x75 NAT [...]x0,85 cm] P73 V3 4 class 3 C R11



FOREST ÂMBAR **
15x75 NAT [...]x0,85 cm] P70 V3 4 class 1 A R9 U2P3E3C2

ANTISLIP FOREST ÂMBAR
15x75 NAT [...]x0,85 cm] P73 V3 4 class 3 C R11

DIVERSAS FORMAS DE APLICAÇÃO: · DIFFERENT WAYS OF APPLICATION:
DIFFÉRENTS MODES D'APPLICATION: · DIVERSAS FORMAS DE APLICACIÓN:

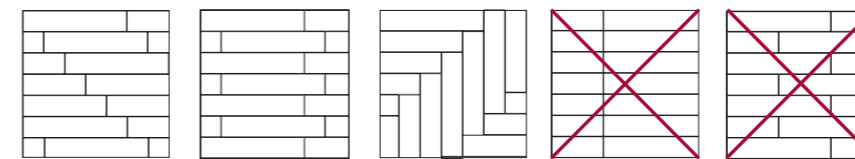

IDEAL PARA PISO RADIANTE
IDEAL FOR UNDERFLOOR HEATING
IDÉAL SUR SOLS CHAUFFANTS
IDEAL PARA SUELO RADIANTE

	PEÇA / PIECE	PEÇA / PIECE
DG	Nat	RB
15x75 cm	P12	7,5x75 cm
		Nat
		P07

ANTISLIP: Produtos que minimizam o risco de deslizamento.
ANTISLIP: Products that minimize the risk of slipping.
ANTISLIP: Produits qui réduisent le risque de glissement.
ANTISLIP: Productos que minimizan el riesgo de deslizamiento.

Dada a dimensão do produto e devido às tolerâncias de planaridade permitidas (de acordo com as normas internacionais), recomendamos a aplicação em paralelo e, no caso de aplicação em contrafiada, no máximo, a ¼ da peça.
Given the product's size and due to the planar tolerances allowed (in accordance with international standards), we recommend the parallel application and, if applied interrupting the joints, we recommend a maximum ¼ application from the piece.
Étant donnée la dimension du produit et en raison des tolérances de planitude permises (conformément aux normes internationales), nous recommandons l'application en parallèle et, dans le cas d'application en contre-fil, au maximum d'¼ de la pièce.
Dada la dimensión del producto y debido a las tolerancias de planaridad permitidas (de acuerdo con las normas internacionales), le recomendamos la aplicación en paralelo y, en caso de aplicación en asiento, como máximo, a ¼ de la pieza.

Deck Forest

- 04** cores
couleurs
colores
- 01** formato
format
formato
- 01** acabamento
finish
finition
acabado



DECK FOREST BEGE ****
15x75 NAT [...]x0,85 cm] P73 V3 4 class 3 C R13



DECK FOREST NUDE ****
15x75 NAT [...]x0,85 cm] P73 V3 4 class 3 C R13



DECK FOREST GRIS ****
15x75 NAT [...]x0,85 cm] P73 V3 4 class 3 C R13



DECK FOREST ÂMBAR ***
15x75 NAT [...]x0,85 cm] P73 V3 4 class 3 C R13



Wood

Wood

Peças / Pieces		Caixa / Box			Europalet / Europallet			
15x75 cm	Nat.	Espessura (mm) / Thickness (mm)	Nº Peças / No Pieces	M² Aprox. / No of Sq. M. Approx.	Peso (Kg) / Weight Kg	Nº Caixas / No Boxes	M² Aprox. / No of Sq. M. Approx.	Peso (Kg) / Weight (Kg)
		± 8,5 ±5%	8	0,9	17,5	64	57,6	1 141

PEÇA / PIECE	
RB	Nat
	P07

DECK: Produtos que minimizam o risco de deslizamento.
DECK: Products that minimize the risk of slipping.
DECK: Produits qui réduisent le risque de glissement.
DECK: Productos que minimizan el riesgo de deslizamiento.

Dada a dimensão do produto e devido às tolerâncias de planaridade permitidas (de acordo com as normas internacionais), recomendamos a aplicação em paralelo e, no caso de aplicação em contrafiada, no máximo, a ¼ da peça.
Given the product's size and due to the planar tolerances allowed (in accordance with international standards), we recommend the parallel application and, if applied interrupting the joints, we recommend a maximum ¼ application from the piece.
Étant donné la dimension du produit et en raison des tolérances de planitude permises (conformément aux normes internationales), nous recommandons l'application en parallèle et, dans le cas d'application en contre-fil, au maximum d'¼ de la pièce.
Dada la dimensión del producto y debido a las tolerancias de planaridad permitidas (de acuerdo con las normas internacionales), le recomendamos la aplicación en paralelo y, en caso de aplicación en asiento, como máximo, a ¼ de la pieza.

Ao aplicar as peças na mesma direção, o ligeiro desalinhamento da parte lisa e/ou das raias é uma característica intrínseca ao produto. Recomendamos a utilização de junta de, aproximadamente, 3 mm.
When applying pieces in the same direction, the slight deviation of the flat part and /or stripes is a characteristic intrinsic to the product. We recommend the use of joint of approximately 3 mm.
Lors de la pose des pièces dans le même sens, le léger décalage de l'alignement de la partie lisse et /ou des rayures est une caractéristique intrinsèque du produit. Nous recommandons l'utilisation d'un joint d'environ 3 mm.
Al aplicar las piezas en la misma dirección, la ligera desalineación de la parte lisa y/o de las rayas es una característica intrínseca al producto. Le recomendamos el uso de una junta de, aproximadamente, 3 mm.

- 04** cores
colors
couleurs
colors
- 01** formato
format
format
formato
- 01** acabamento
finish
finition
acabado

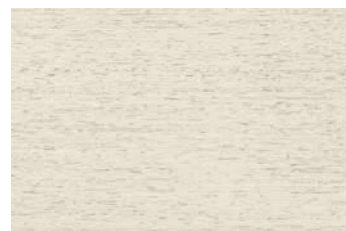

STAMPA OFFWHITE
30x45 NAT [... 0,90 cm] P63

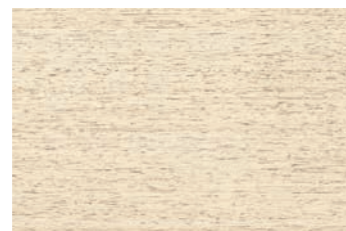

STAMPA BEGE
30x45 NAT [... 0,90 cm] P63



STAMPA GRIS
30x45 NAT [... 0,90 cm] P63



STAMPA TABAC
30x45 NAT [... 0,90 cm] P63



STAMPA MIX GRIS (*)
30x45 NAT [... 0,90 cm] P69



STAMPA MIX BEGE (*)
30x45 NAT [... 0,90 cm] P69

Peças / Pieces		Caixa / Box			Europaleta / Europallet			
30x45 cm (12"x18")	Nat.	Espeçura (mm) Thickness (mm)	Nº Peças No Pieces	M² Aprox. No of Sq. M. Approx.	Peso (Kg) Weight Kg	Nº Caixas No Boxes	M² Aprox. No of Sq. M. Approx.	Peso (Kg) Weight (Kg)
		± 9,0 ± 5 %	11	1.5	23.9	48	72	1.166

(*) Existem 6 peças diferentes, de acordo com o desenho do decorado, que devem ser aplicadas alternadamente, de modo a obter-se uma solução mais rica e variada.
 (*) There are 6 pieces, matching the design of the decorated tiles, which should be applied alternately in order to obtain a richer and more varied decoration.
 (*) 6 pièces correspondent au dessin du décor. Il convient de les appliquer de façon alternée pour obtenir une disposition plus riche et plus variée.
 (*) Existen 6 piezas diferentes, de acuerdo con el diseño del decorado, que deben aplicarse de forma alterna, con el fin de obtener una solución más y variada.

Tendo em vista alcançar um efeito global mais real e harmonioso, são produzidas peças diferentes umas das outras com variações de desenho e/ou cores entre elas.
 For a more genuine and harmonious effect overall, different tiles with design and/or colour variations are produced.
 Afin d'obtenir un effet global plus réel et harmonieux, nos pièces sont différentes les unes des autres avec des variations de dessin et / ou de nuances entre elles.
 Para lograr un efecto global más real y armonioso, se producen piezas diferentes unas de otras con variaciones de diseño y/o color.



Stampa Bege
Stampa Mix Bege
Stampa Tabac
Forest Bege



Rustic

Página
Page
Page
Página

Fórum	344
Arizona	346
Edicer Santana	348
Edicer Pedralva	350
Penha	352

Vida Ao Ar Livre

Soluções para ambientes que promovem uma extensão perfeita entre o interior e o exterior.

Outdoor Living

Solutions for environments that provide the perfect extension between indoor and outdoor spaces.

Vie En Plein Air

Solutions pour des environnements qui promeuvent une extension parfaite entre l'intérieur et l'extérieur.

Vida Al Aire Libre

Soluciones para ambientes que facilitan una prolongación perfecta entre el interior y el exterior.

Fórum

- 01** cor
color
couleur
color
- 01** formato
format
format
formato
- 01** acabamento
finish
finition
acabado



Class 3



FÓRUM 1 *****
30x60 NAT [...x0,85 cm] P65 V3 class 3



FÓRUM 2 *****
30x60 NAT [...x0,85 cm] P65 V3 class 3

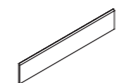

PEÇA _PIECE	
RB	NAT
9,5x30 cm	P04
8x60 cm	P08

Peças_Pieces		Caixa_Box			Europaleta_Europallet			
30x60 cm (12"x24")	Nat.	Espessura (mm) Thickness (mm)	Nº Peças No Pieces	M² Aprox. No of Sq. M. Approx.	Peso (Kg) Weight Kg	Nº Caixas No Boxes	M² Aprox. No of Sq. M. Approx.	Peso (Kg) Weight (Kg)
		± 8,5 ±5%	5	0.9	18	48	43.2	837

Tendo em vista alcançar um efeito global mais real e harmonioso, são produzidas 5 peças diferentes umas das outras com variações de desenho e/ou cores entre elas.
In order to reach a more genuine and consistent global effect, 5 different pieces with design and/or colour variations are produced.
Afin d'obtenir un effet global plus réel et harmonieux, nous produisons plusieurs 5 pièces différentes les unes des autres avec des variations de dessin et/ou de couleurs entre elles.
Para lograr un efecto global más real y armonioso, se pueden realizar 5 piezas diferentes unas de otras con modificaciones de diseño y/o color.

Fórum



Fórum 1
Fórum 2
Forest Nude

Rustic

Rustic

Arizona

Arizona

- 06** cores
colors
couleurs
colores
- 01** formato
format
format
formato
- 01** acabamento
finish
finition
acabado



Class 3

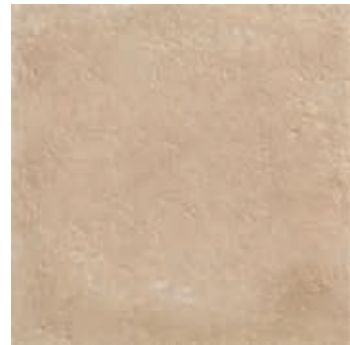

ARIZONA BEGE ****
45x45 NAT [...]x0,82 cm] P67 V3 3 class 3

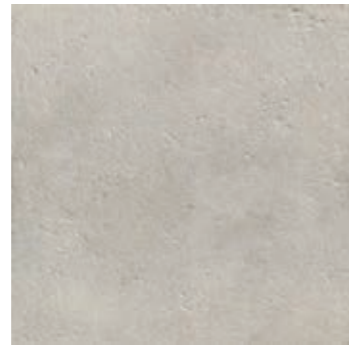

ARIZONA FOG ****
45x45 NAT [...]x0,82 cm] P67 V3 3 class 3



ARIZONA ANTRACITE ****
45x45 NAT [...]x0,82 cm] P67 V3 3 class 3



ARIZONA BRICK ****
45x45 NAT [...]x0,82 cm] P67 V3 3 class 3



ARIZONA CORAL ****
45x45 NAT [...]x0,82 cm] P67 V3 3 class 3



ARIZONA TERRACOTTA ****
45x45 NAT [...]x0,82 cm] P67 V3 3 class 3

PEÇA _ PIECE		PEÇA _ PIECE	
DG	Nat	RB	Nat
45x45 cm	P10	8x45 cm	P07

Peças_Pieces		Caixa_Box			Europaleta_Europallet			
45x45 cm (18"x18")	Nat.	Espessura (mm) Thickness (mm)	Nº Peças No Pieces	M² Aprox. No of Sq. M. Approx.	Peso (Kg) Weight Kg	Nº Caixas No Boxes	M² Aprox. No of Sq. M. Approx.	Peso (Kg) Weight (Kg)
		8,2 ±5%	6	1.22	24	34	41.48	837

Tendo em vista alcançar um efeito global mais real e harmonioso, são produzidas até 8 peças diferentes umas das outras com variações de desenho e/ou cores entre elas. In order to reach a more genuine and consistent global effect, 8 different pieces with design and/or colour variations are produced. Afin d'obtenir un effet global plus réel et harmonieux, nous produisons plusieurs 8 pièces différentes les unes des autres avec des variations de dessin et/ou de couleurs entre elles. Para lograr un efecto global más real y armonioso, se pueden realizar 8 piezas diferentes unas de otras con modificaciones de diseño y/o color.



Arizona Fog
Arizona Antracite

Rustic

Rustic

Edicer Santana

- 03** cores
colors
couleurs
colores
- 01** formato
format
format
formato
- 01** acabamento
finish
finition
acabado



Class 1



EDICER SANTANA AREIA *****
45x45 NAT [...]x0,82 cm] P59 V3 3 class 1



EDICER SANTANA BEGE *****
45x45 NAT [...]x0,82 cm] P59 V3 3 class 1

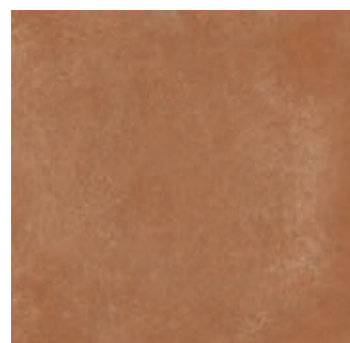

EDICER SANTANA CORAL *****
45x45 NAT [...]x0,82 cm] P59 V3 3 class 1



Rustic

Rustic

PEÇA _ PIECE		PEÇA _ PIECE	
DG	Nat	RB	Nat
45x45 cm	P08	8x45 cm	P05

Peças_Pieces		Caixa_Box			Europalette_Europallet			
45x45 cm (18"x18")	Nat.	Espessura (mm) Thickness (mm)	Nº Peças No Pieces	M² Aprox. No of Sq. M. Approx.	Peso (Kg) Weight (Kg)	Nº Caixas No Boxes	M² Aprox. No of Sq. M. Approx.	Peso (Kg) Weight (Kg)
		8,2 ±5%	6	1.22	24	34	41.48	837

Tendo em vista alcançar um efeito global mais real e harmonioso, são produzidas peças diferentes umas das outras com variações de desenho e/ou cores entre elas.
In order to reach a more genuine and consistent global effect, different pieces with design and/or colour variations are produced.

Afin d'obtenir un effet global plus réel et harmonieux, nous produisons plusieurs pièces différentes les unes des autres avec des variations de dessin et/ou de couleurs entre elles.

Para lograr un efecto global más real y armonioso, se pueden realizar piezas diferentes unas de otras con modificaciones de diseño y/o color.

Edicer Pedralva

Edicer Pedralva

- 04** cores
colors
couleurs
colores
- 01** formato
format
format
formato
- 01** acabamento
finish
finition
acabado



Class 3



EDICER PEDRALVA DUNA *****
45x45 NAT [...]x0,82 cm] P59 V3 class 3



EDICER PEDRALVA CINZA *****
45x45 NAT [...]x0,82 cm] P59 V3 class 3



EDICER PEDRALVA BEGE *****
45x45 NAT [...]x0,82 cm] P59 V3 class 3



EDICER PEDRALVA ÂMBAR *****
45x45 NAT [...]x0,82 cm] P59 V3 class 3



Rustic

Rustic

Peças_Pieces		Caixa_Box			Europaleta_Europallet		
Espessura (mm) Thickness (mm)	Nº Peças No Pieces	M² Aprox. No of Sq. M. Approx.	Peso (Kg) Weight Kg	Nº Caixas No Boxes	M² Aprox. No of Sq. M. Approx.	Peso (Kg) Weight (Kg)	
45x45 cm (18"x18") Nat.	8,2 ±5%	6	1,22	24	34	41,48	837

PEÇA_PIECE		PEÇA_PIECE	
DG	Nat	RB	Nat
45x45 cm	P08	8x45 cm	P05

EDICER PEDRALVA: Productos que minimizam o risco de deslizamento
EDICER PEDRALVA: Products that minimize the risk of slipping.
EDICER PEDRALVA: Produits qui réduisent le risque de glissement.
EDICER PEDRALVA: Productos que minimizan el riesgo de deslizamiento.

Edicer Pedralva Bege

Penha

- 02** cores
colors
couleurs
colores
- 01** formato
format
format
formato
- 01** acabamento
finishe
finition
acabado



Class 3



PENHA BEGE *****
45x45 NAT [...]x0,82 cm] P60 V2 3 class 3



PENHA CINZA *****
45x45 NAT [...]x0,82 cm] P60 V2 3 class 3



Rustic

Rustic

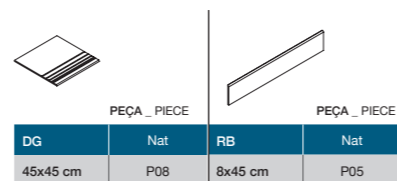

Peças_Pieces		Caixa_Box			Europalette_Europallet			
Espessura (mm) Thickness (mm)	Nº Peças No Pieces	M² Aprox. No of Sq. M. Approx.	Peso (Kg) Weight (Kg)	Nº Caixas No Boxes	M² Aprox. No of Sq. M. Approx.	Peso (Kg) Weight (Kg)		
45x45 cm (18"x18")	Nat.	± 8,2 ±5%	6	1,22	24	34	41,48	837

PENHA: Produtos que minimizam o risco de deslizamento
PENHA: Products that minimize the risk of slipping.
PENHA: Produits qui réduisent le risque de glissement.
PENHA: Productos que minimizan el riesgo de deslizamiento.



Decors

Decorados, listelos e barras _ Decors, listels and bars
Décors, listels et bandes _ Decorados, listeles y barras

Decors

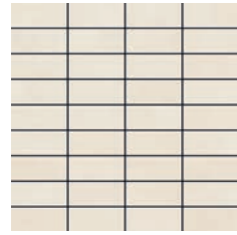

CROSS 36
SILKEN BRANCO (a)
30x30 P17 / peça_peice

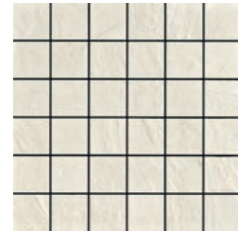

STRATUS 36
XISTO SUPERBRANCO (a) (f)
30x30 P19 / peça_peice

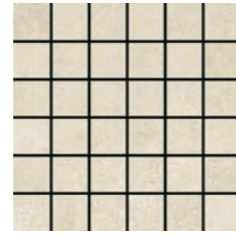

STRATUS 36
URBAN OFFWHITE (a) (f)
30x30 P19 / peça_peice

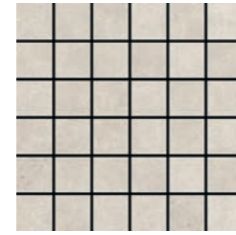

STRATUS 36
PLANET OFFWHITE (a) (f)
30x30 P19 / peça_peice

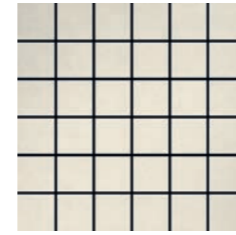

STRATUS 36
VOGUE WHITE (a) (f)
30x30 P19 / peça_peice

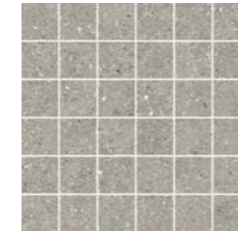

STRATUS 36
ELEMENTS FOG (a) (f)
30x30 SOFT P19 / peça_peice



MULTIFORM ELEMENTS FOG (a)
30x30 P20 / peça_peice

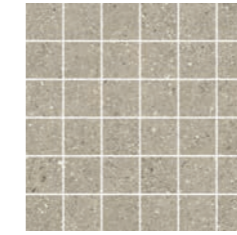

STRATUS 3
ELEMENTS SMOKE (a) (f)
30x30 SOFT P19 / peça_peice

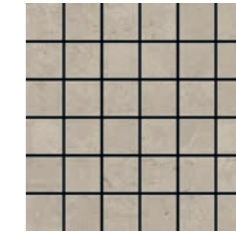

STRATUS 36 GLOBE FOG (a) (f)
30x30 P19 / peça_peice

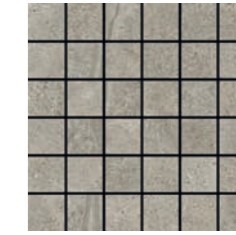

STRATUS 36
LAVASTONE FOG (a) (f)
30x30 P19 / peça_peice



MULTIFORM ELEMENTS MIST (a)
30x30 P20 / peça_peice



STRATUS 36
ELEMENTS MIST (a) (f)
30x30 SOFT P19 / peça_peice



STRATUS 36
CITYZEN OFFWHITE (a) (f)
30x30 P19 / peça_peice

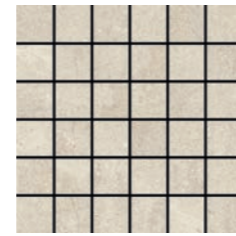

STRATUS 36
LAVASTONE PLATINA (a) (f)
30x30 P19 / peça_peice

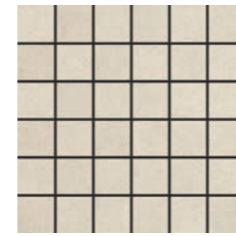

STRATUS 36
GLOBE BRANCO (a) (f)
30x30 P19 / peça_peice



STRATUS 36 CITYZEN FOG (a) (f)
30x30 P19 / peça_peice

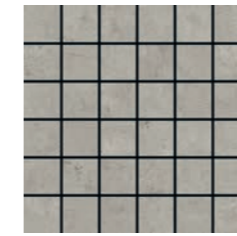

STRATUS 36 GLOBE GRIS (a) (f)
30x30 P19 / peça_peice

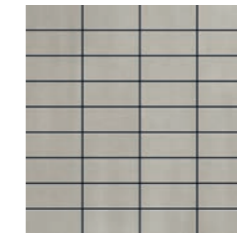

CROSS 36 SILKEN GRIS (a)
30x30 P17 / peça_peice

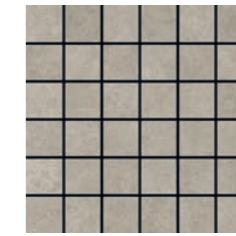

STRATUS 36 URBAN FOG (a) (f)
30x30 P19 / peça_peice

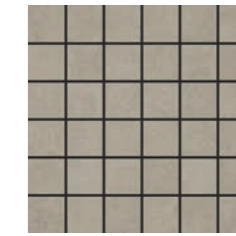

STRATUS 36 GLOBE CORDA (a) (f)
30x30 P19 / peça_peice

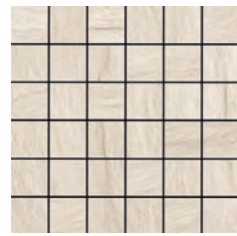

STRATUS 36 XISTO MARFIM (a) (f)
30x30 P19 / peça_peice

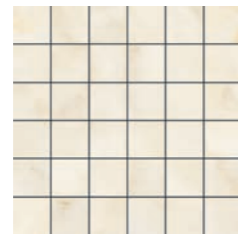

STRATUS 36 BIANCO ORO (a)
30x30 P17 / peça_peice

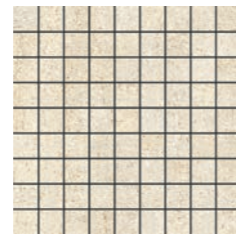

STRATUS 81
MOKA CREME BRILHO (a) (f)
MOKA CREME MATE (a)
30x30 P19 / peça_peice

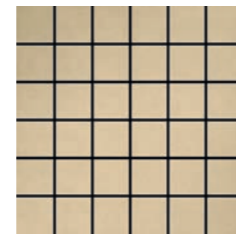

STRATUS 36 VOGUE PERLA (a) (f)
30x30 P19 / peça_peice



MULTIFORM ELEMENTS SMOKE (a)
30x30 P20 / peça_peice

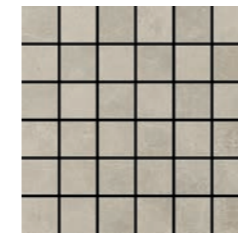

STRATUS 36 PLANET PLATINA (a) (f)
30x30 P19 / peça_peice

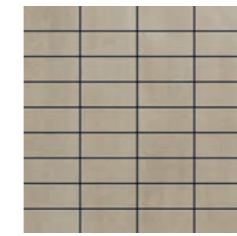

CROSS 36 SILKEN CORDA (a)
30x30 P17 / peça_peice

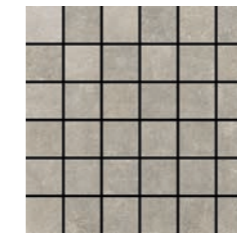

STRATUS 36 PLANET FOG (a) (f)
30x30 P19 / peça_peice

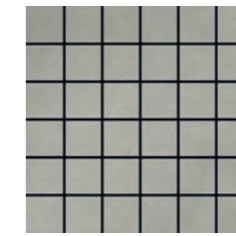

STRATUS 36 VOGUE SILVER (a) (f)
30x30 P19 / peça_peice

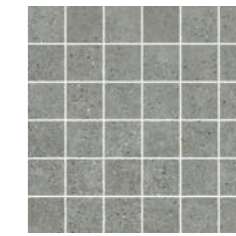

STRATUS 36 CITYZEN GRIS (a) (f)
30x30 P19 / peça_peice

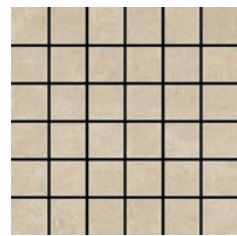

STRATUS 36 URBAN BONE (a) (f)
30x30 P19 / peça_peice

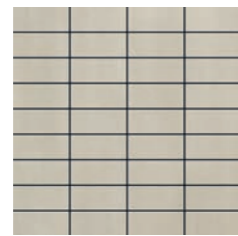

CROSS 36 SILKEN FOG (a)
30x30 P17 / peça_peice

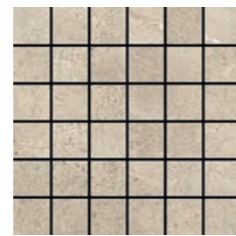

STRATUS 36
LAVASTONE BONE (a) (f)
30x30 P19 / peça_peice

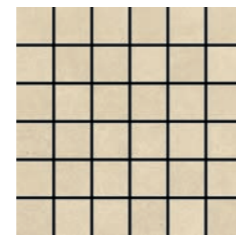

STRATUS 36
PLANET MARFIM (a) (f)
30x30 P19 / peça_peice

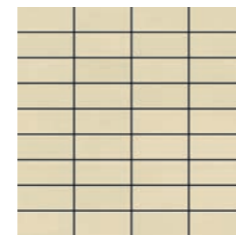

CROSS 36 SILKEN BEGE (a)
30x30 P17 / peça_peice

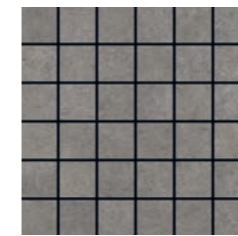

STRATUS 36 URBAN GRIS (a) (f)
30x30 P19 / peça_peice

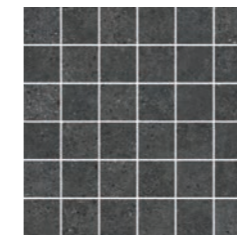

STRATUS 36
CITYZEN CARBON (a) (f)
30x30 P19 / peça_peice



STRATUS 36
LAVASTONE ANTRACITE (a) (f)
30x30 P19 / peça_peice

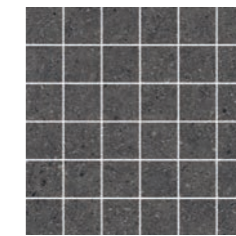

STRATUS 36
ELEMENTS CARBON (a) (f)
30x30 SOFT P19 / peça_peice

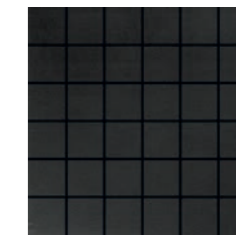

STRATUS 36
VOGUE BLACK (a) (f)
30x30 P19 / peça_peice

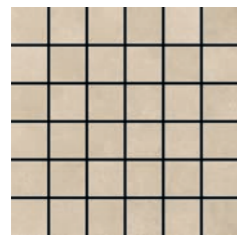

STRATUS 36 PLANET BEGE (a) (f)
30x30 P19 / peça_peice



STRATUS 36
CITYZEN BONE (a) (f)
30x30 P19 / peça_peice

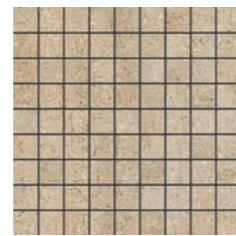

STRATUS 81
MOKA CRAFT BRILHO (a) (f)
MOKA CRAFT MATE (a)
30x30 P19 / peça_peice

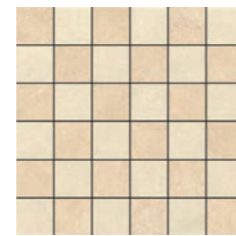

STRATUS 36 NIMBUS MIX BEGE (a)
30x30 P17 / peça_peice

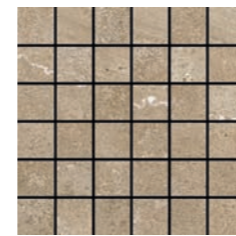

STRATUS 36
LAVASTONE BEGE (a) (f)
30x30 P19 / peça_peice

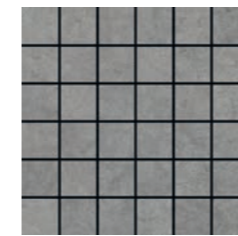

STRATUS 36 GLOBE GRAFITE (a) (f)
30x30 P19 / peça_peice

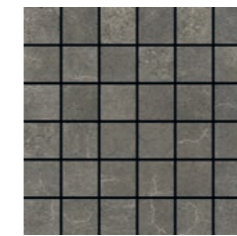

STRATUS 36 PLANET GRIS (a) (f)
30x30 P19 / peça_peice



STRATUS 36
VOGUE TABAC (a) (f)
30x30 P19 / peça_peice

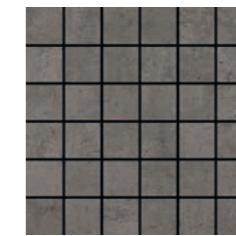

STRATUS 36
GLOBE ANTRACITE (a) (f)
30x30 P19 / peça_peice



STRATUS 36
URBAN ANTRACITE (a) (f)
30x30 P19 / peça_peice

Decors



HEXA STATUARIO (a) (d) (f)
24x30 P32 / peça_peice



PEAK ABSOLUT(a) (d) (f)
30x30 P32 / peça_peice



MODULUS STATUARIO (a) (d) (f)
33x37 P32 / peça_peice



BYZANTINE (a) (b) (d) (f)
30x52 P32 / peça_peice

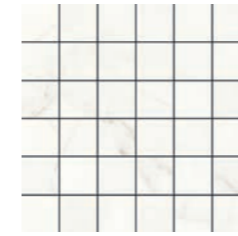

STRATUS 36 BIANCO SIVEC (a)
30x30 P17 / peça_peice

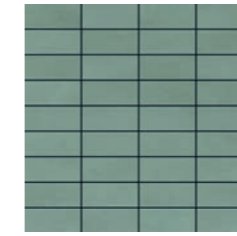

CROSS 36 SILKEN JADE (a)
30x30 P17 / peça_peice

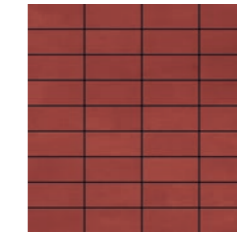

CROSS 36 SILKEN RUBI (a)
30x30 P17 / peça_peice

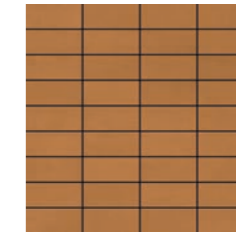

CROSS 36 SILKEN CARAMEL (a)
30x30 P17 / peça_peice



CROSS 36 SILKEN OCEAN (a)
30x30 P17 / peça_peice



STRATUS 9 XISTO SUPERBRANCO (a) (f)
30x30 P19 / peça_peice

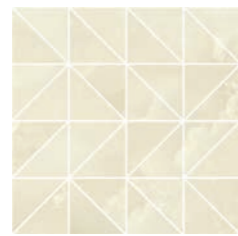

LUX ONIX (a)
30x30 P21 / peça_peice



LUX GOLD ONIX (a)
30x30 P26 / peça_peice

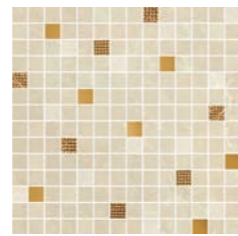

VERSUS PULPIS BEGE (a) (b)
30x30 P34 / peça_peice

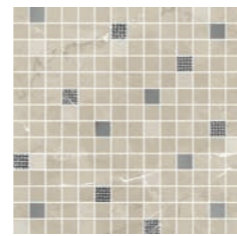

VERSUS PULPIS PLATINA (a) (b)
30x30 P34 / peça_peice

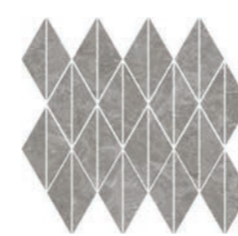

PYRAMID GREY (a) (b) (d) (f)
28x30 P26 / peça_peice



SCARPA EMPERADOR (a) (d) (f)
30x33 P32 / peça_peice

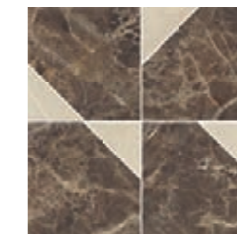

NEXUS (a) (f)
30x30 POL P32 / peça_peice

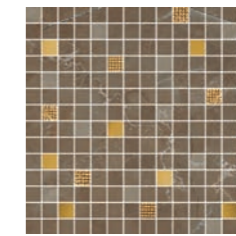

VERSUS PULPIS TABAC (a) (b)
30x30 P34 / peça_peice



STEP GOLD (a)
30x30 P97 / peça_peice



STRATUS 9 XISTO MARFIM (a) (f)
30x30 P19 / peça_peice



DUO 8 XISTO MARFIM (a)
30x30 P21 / peça_peice



DUO 36 XISTO MARFIM (a)
30x30 P21 / peça_peice



STRATUS 36 URBAN CRAFT (a) (f)
30x30 P19 / peça_peice



STRATUS 36 YURA BEGE (a) (f)
30x30 P19 / peça_peice

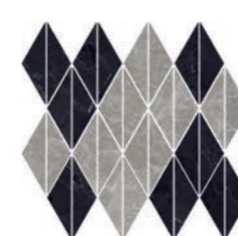

PYRAMID BLACK & GREY (a) (b) (d) (f)
28x30 P28 / peça_peice



TALISMAN IRON (a)
30x30 P47 / peça_peice



COLUNATTA 2 XISTO PRETO (a)
30x30 P43 / peça_peice



STRATUS 36 VOGUE BRONZE (a) (f)
30x30 P19 / peça_peice



COLUNATTA 3 COPPER (a)
30x30 P48 / peça_peice

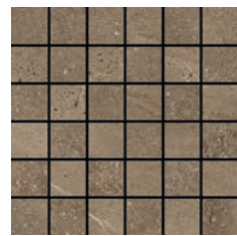

STRATUS 36 LAVASTONE CRAFT (a) (f)
30x30 P19 / peça_peice

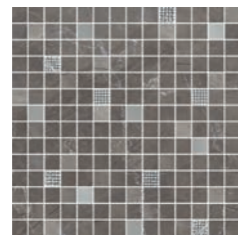

VERSUS PULPIS GRIS (a) (b)
30x30 P34 / peça_peice



STEP SILVER (a)
30x30 P97 / peça_peice



STRATUS 36 NIMBUS MIX GRIS (a)
30x30 P17 / peça_peice



TARSUS (a) (b) (d) (f)
29x29 P36 / peça_peice



STRATUS 9 SLATE MULTICOLOR (a) (f)
30x30 P22 / peça_peice

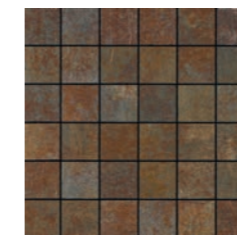

STRATUS 36 XISTO MULTICOLOR (a) (f)
30x30 P19 / peça_peice



STEP COPPER (a)
30x30 P29 / peça_peice



STRATUS 9 XISTO MULTICOLOR (a) (f)
30x30 P19 / peça_peice



STRATUS 36 YURA CINZA (a) (f)
30x30 P19 / peça_peice



CROSS 36 SILKEN ANTRACITE (a)
30x30 P17 / peça_peice

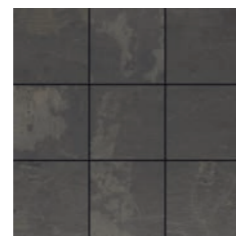

STRATUS 9 SLATE ANTRACITE (a) (f)
30x30 P22 / peça_peice



MULTIFORM ELEMENTS CARBON (a)
30x30 P20 / peça_peice



STRATUS 36 XISTO PRETO (a) (f)
30x30 P19 / peça_peice



ZIG ZAG AFYON GRIS (a)
15x45 P28 / peça_peice



ZIG ZAG AFYON GRAFITE (a)
15x45 P28 / peça_peice



ZIG ZAG AFYON BONE (a)
15x45 P28 / peça_peice



ZIG ZAG AFYON FOG (a)
15x45 P28 / peça_peice



STEP IRON (a)
30x30 P29 / peça_peice



DUO 36 XISTO PRETO (a)
30x30 P21 / peça_peice



STRATUS 9 XISTO PRETO (a) (f)
30x30 P19 / peça_peice

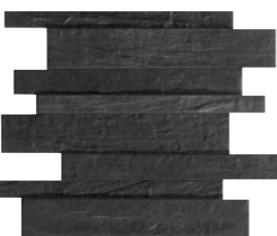

DUO 8 XISTO PRETO (a)
30x30 P21 / peça_peice



MODULUS ABSOLUT (a) (d) (f)
33x37 P32 / peça_peice

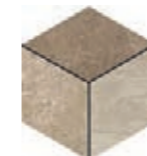

TRIO AFYON BONE (a) (f)
20x22 P22 / peça_peice



TRIO AFYON GRIS (a) (f)
20x22 P22 / peça_peice



TRIO VENEZIA BIANCO (a) (d) (f)
20x22 P22 / peça_peice

Decors



LOKI TAUPE (a) (b) (f)
19,5x19,5 [19,5x19,5x1,05 cm] P15 / peça_piece



LOKI WHITE (a) (b) (f)
19,5x19,5 [19,5x19,5x1,05 cm] P15 / peça_piece



LOKI CHERRY (a) (b) (f)
19,5x19,5 [19,5x19,5x1,05 cm] P15 / peça_piece



LOKI NUT (a) (b) (f)
19,5x19,5 [19,5x19,5x1,05 cm] P15 / peça_piece



ODIN TAUPE (a) (b) (f)
30x30 [29,6x29,6x1,05 cm] P19 / peça_piece



ODIN WHITE (a) (b) (f)
30x30 [29,6x29,6x1,05 cm] P19 / peça_piece



ODIN CHERRY (a) (b) (f)
30x30 [29,6x29,6x1,05 cm] P19 / peça_piece



ODIN NUT (a) (b) (f)
30x30 [29,6x29,6x1,05 cm] P19 / peça_piece

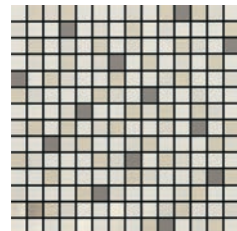

BIT MIX IRON (a)
30x30 P42 /peça_piece



KITSCH (a) (b)
30x30 P28 /peça_piece

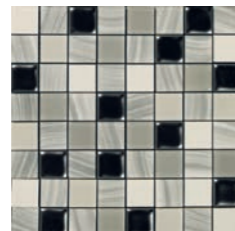

XADREZ CINZA (a)
28x28 P86 /peça_piece



BARRA GLAM OURO
1x60 RECT [1x59,2x0,9 cm] P25

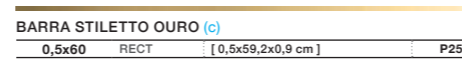

BARRA STILETTO OURO (c)
0,5x60 RECT [0,5x59,2x0,9 cm] P25



BARRA STILETTO VERMELHO (c)
0,5x60 RECT [0,5x59,2x0,9 cm] P25

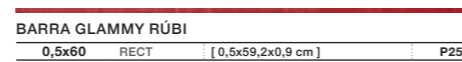

BARRA GLAMMY RÚBI
0,5x60 RECT [0,5x59,2x0,9 cm] P25

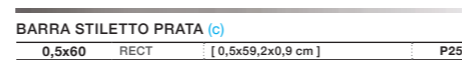

BARRA STILETTO PRATA (c)
0,5x60 RECT [0,5x59,2x0,9 cm] P25

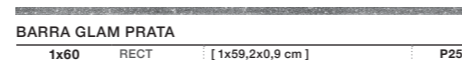

BARRA GLAM PRATA
1x60 RECT [1x59,2x0,9 cm] P25

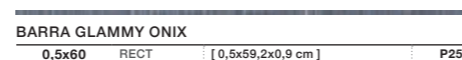

BARRA GLAMMY ONIX
0,5x60 RECT [0,5x59,2x0,9 cm] P25



XADREZ AQUA (a)
28x28 P86 /peça_piece

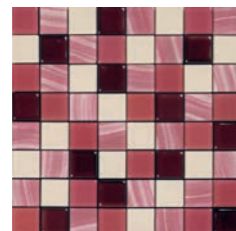

XADREZ CARMIM (a)
28x28 P86 /peça_piece



XADREZ BEGE (a)
28x28 P86 /peça_piece



PASSARELLE PALM (a)
30x30 P21 /peça_piece



PASSARELLE TEAL (a)
30x30 P21 /peça_piece



PASSARELLE WHITE (a)
30x30 P21 /peça_piece

NOTAS . NOTES . NOTES . NOTAS

- (a) Os decorados (colados em rede) podem ser conjugados com qualquer medida da base pois devido às suas características, permitem obter um efeito de continuidade.
 (a) The decors (glued on a net) can be used with any tile base size because they allow an effect of continuity given their characteristics.
 (a) Les décors (collés sur filet) peuvent être conjugués avec toute autre mesure de la base, car leurs caractéristiques permettent d'obtenir un effet continu.
 (a) Los decorados (encolados en red) se pueden combinar con cualquier medida de la base pues, gracias a sus características, permiten obtener un efecto de continuidad.

- (b) Existem várias peças diferentes, de acordo com o desenho do decorado, que devem ser aplicadas alternadamente, de modo a obter-se uma solução mais rica e variada.
 (b) There are different pieces, matching the design of the decorated tiles, which should be applied alternately in order to obtain a richer and more varied decoration.
 (b) Différentes pièces correspondent au dessin du décor. Il convient de les appliquer de façon alternée pour obtenir une disposition plus riche et plus variée.
 (b) Existen diversas piezas diferentes, de acuerdo con el diseño del decorado, que deben aplicarse de forma alterna, con el fin de obtener una solución más y variada.

- (c) A barra tem 2 lados distintos: uma face de brilho uniforme e a outra face com efeito escovado. Qualquer face da barra poderá ser aplicada, utilizando a que melhor se adapte ao ambiente.
 (c) This bar has 2 different sides: one side has a uniform brightness and the other side has a brushed effect. Both sides of the bar can be applied, according to the chosen ambience.
 (c) La barre a 2 côtés distincts : l'une des faces présente un brillant uniforme et l'autre a un effet brossé. On pourra appliquer l'une ou l'autre, en optant pour celle qui s'adapte le mieux à l'environnement.
 (c) La barra tiene 2 lados distintos: una cara tiene brillo uniforme y la demás tiene un efecto cepillado. Cualquier cara de la barra podrá aplicarse utilizando la que se adapte mejor al medio ambiente.

- (g) Decorado composto pela mistura de peças em acabamento mate e polido.
 (g) Decor composed of a mix of pieces with matt and polished finishes.
 (g) Décor composé d'un mélange de pièces avec des finitions matt et polie.
 (g) Decorado compuesto por una mezcla de piezas con acabados mate y pulido.

- (f) Decorados aplicáveis em revestimento e, também, em pavimento.
 (f) Decors for wall tiles and also for floor tiles.
 (f) Décors applicables aussi bien en revêtements muraux, qu'en revêtements de sol.
 (f) Decorados aplicables en revestimiento y, también, en pavimento.

Relativamente aos decorados, especialmente nos produtos em vidro ou metalizados a ouro ou platina, não devem ser utilizados utensílios ou produtos de limpeza ácidos ou abrasivos, os quais poderão danificar a decoração.

On decorative tile, especially on glass and/or gold or platinum metallic surfaces, do not use tools or acid and/or abrasive cleaning products, which may damage the decorative surface.

Pour le carrelage décor, en particulier les produits en verre et / ou métallisés or ou platine, des ustensiles ou des produits de nettoyage acides et/ou abrasifs ne doivent pas être utilisés car ils peuvent endommager la décoration.

Con respecto a las decoraciones, especialmente en los productos de vidrio o metalizados en oro o platino, no se deben utilizar utensilios ni productos ácidos o abrasivos, ya que podrían dañar la decoración.



Revigrés Tech

	Página
	Page
	Page
	Página
Revicomfort	364
Revisilent	366
Revisense	368
Revicare	370
Deck Smart	372
Fachada Ventilada	374
Antiderrapante	376

Pavimento em grés porcelânico amovível e reutilizável
 Removable and reusable full body porcelain floor tile
Sol en grès cérame portable et réutilisable
 Pavimento en gres porcelánico portátil y reutilizable



REVICOMFORT

Esta solução pode ser produzida, sob encomenda, para várias coleções com superfície lisa (várias cores, efeitos e texturas). Solicitamos consulta específica ao Departamento Comercial.

Instalação: consulte a página 409 deste catálogo.

REVICOMFORT

This solution can be produced on request for various collections with flat surface (several colors, effects and textures). We recommend you address your special request with the Commercial Department.

Installation: see page 409 of this catalogue.

REVICOMFORT

Cette solution peut être produite, sur commande, pour différentes collections avec une surface lisse (différentes couleurs, effets et textures). Nous demandons une consultation spécifique avec le Département Commercial.

Installation : veuillez consulter la page 409 de ce catalogue.

REVICOMFORT

Esta solución puede realizarse, bajo petición, para varias colecciones con superficie lisa (diferentes colores, efectos y texturas). Para más información, consulte con el Departamento Comercial.

Instalación: consulte la página 409 de este catálogo.



60x60 cm
MATT RECT · RECT · SOFT · LAP · POL

Arestas laterais e tardo (reverso) em polímero. Espessura total: ± 11,5 mm
 Side edges and back (reverse) in polymer. Total thickness: ± 11,5 mm
Les bords latéraux et la face interne du carreau en polymère. Épaisseur totale: ± 11,5 mm
 Los bordes laterales y el dorso en polímero. Espesor total: ± 11,5 mm

Prémio Internacional A' Design Award Gold
 International A' Design Award Gold

Grande Prémio de Marketing e Inovação. Produto do Ano 2014
 Consumer Survey of Product Innovation. Product of The Year 2014

Troféu Inovação atribuído pela Câmara de Comércio e Indústria Luso-Francesa
 Innovation Trophy given by the Portuguese-French Chamber of Commerce and Industry

Tektónica: Prémio Inovação
 Innovation Award

Prémio Inovação na Construção
 Innovation in Construction Award

Vantagens _ Advantages _ Avantages _ Ventajas:



ECO EFICIENTE: AMOVÍVEL E REUTILIZÁVEL
REDUZ OS RESÍDUOS DE OBRA
 ECO-EFFICIENT: REMOVABLE AND REUSABLE
 REDUCES WORKS' WASTE
ÉCO-EFFICIENT: PORTABLE ET REUTILISABLE
REDUIT LES DECHETS DES TRAVAUX
 ECOEFICIENTE: PORTÁTIL Y REUTILIZABLE
 REDUCE LOS RESIDUOS DE OBRA



FÁCIL DE COLOCAR: SEM COLAS, NEM CIMENTOS
NÃO DANIFICA O PAVIMENTO PREEXISTENTE
 EASY TO INSTALL: NO ADHESIVES NOR CEMENTS
 IT DOES NOT DAMAGE THE PRE-EXISTING FLOORING
FACILE À POSER: SANS COLLES NI CEMENTS
N'ENDOMMAGE PAS LE SOL PRÉEXISTANT
FÁCIL DE COLOCAR: SIN COLAS NI CEMENTOS
NO DAÑA EL PAVIMENTO EXISTENTE



RÁPIDO DE INSTALAR
QUICK TO INSTALL
RAPIDE À INSTALLER
RÁPIDO DE INSTALAR



IDEAL PARA REMODELAÇÕES
IDEAL FOR REMODELLING
IDÉAL POUR LES TRANSFORMATIONS
IDEAL PARA REMODELACIONES



PRONTO A USAR
READY TO USE
PRÊT À L'EMPLOI
LISTO PARA USAR



FÁCIL ACESSO A SISTEMAS OCULTOS
EASY ACCESS TO CONCEALED SYSTEMS
ACCÈS FACILE AUX SYSTÈMES NON APPARENTS
FÁCIL ACCESO A LOS SISTEMAS OCULTOS



CUMPRIMENTO DA LEGISLAÇÃO ACÚSTICA DE RUÍDO
DE IMPACTO PARA LAJES NORMALIZADAS
COMPLIANCE WITH ACOUSTIC LEGISLATION ON IMPACT NOISE
FOR STANDARDISED SLABS
RESPECT DE LA LÉGISLATION ACOUSTIQUE DE BRUIT D'IMPACT
POUR DALLES NORMALISÉES
CUMPLIMIENTO DE LA NORMATIVA ACÚSTICA SOBRE RUIDO
DE IMPACTO PARA PLACAS ESTÁNDAR



BOM ISOLAMENTO TÉRMICO
GOOD THERMAL INSULATION
BONNE ISOLATION THERMIQUE
BUENO AISLAMIENTO TÉRMICO

Pavimento com isolamento acústico. Cerâmica & cortiça
 Soundproof floor tile. Ceramics & cork
Revêtement de sol avec isolation acoustique. Céramique & liège
 Pavimento con aislamiento acústico. Cerámica y corcho



REVISILENT

Esta solução pode ser produzida, sob encomenda, para várias coleções, em várias cores, efeitos e texturas. Solicitamos consulta específica ao Departamento Comercial.

Asentamiento: consulte a página 410 deste catálogo.

REVISILENT

This solution can be produced on request for various collections with several colors, effects and textures. We recommend you address your special request with the Commercial Department.

Laying: see page 410 of this catalogue.

REVISILENT

Cette solution peut être produite, sur commande, pour différentes collections avec différentes couleurs, effets et textures. Nous demandons une consultation spécifique avec le Département Commercial.

Pose : veuillez consulter la page 410 de ce catalogue.

REVISILENT

Esta solución puede realizarse, bajo petición, para varias colecciones con diferentes colores, efectos y texturas. Para más información, consulte con el Departamento Comercial.

Asentamiento: consulte la página 410 de este catálogo.



30x30 · 30x60 · 45x45 · 60x60 cm
MATT RECT · RECT · SOFT · LAP · POL

LAYER T61

Cortiça com 5 mm de espessura
 Cork with 5 mm thickness
Liège de 5 mm d'épaisseur
 Corcho con 5 mm de espesor

Cortiça fornecida por:

Cork supplied by:

Liège fourni par:

Corcho subministrado por:



Vantagens _ Advantages _ Avantages _ Ventajas:



CUMPRIMENTO DA LEGISLAÇÃO ACÚSTICA DE RUIDO DE IMPACTO PARA LAJES NORMALIZADAS
 COMPLIANCE WITH ACOUSTIC LEGISLATION ON IMPACT NOISE FOR STANDARDISED SLABS
RESPECT DE LA LÉGISLATION ACOUSTIQUE DE BRUIT D'IMPACT POUR DALLES NORMALISÉES
 CUMPLIMIENTO DE LA NORMATIVA ACÚSTICA SOBRE RUIDO DE IMPACTO PARA PLACAS ESTÁNDAR



DISPENSA A APLICAÇÃO DE UM SUBPAVIMENTO COM INCORPORAÇÃO DO ISOLAMENTO ACÚSTICO E DE BETONILHA FLUTUANTE
 DOES NOT REQUIRE THE APPLICATION OF AN UNDERLAY WITH THE INCORPORATION OF SOUNDPROOFING AND A FLOATING SCREED
DISPENSE D'APPLIQUER UN SOUS-PLANCHER AVEC UNE ISOLATION ACOUSTIQUE ET UNE CHAPE FLOTTANTE
 NO PRECISA LA APLICACIÓN DE SUELO BASE CON INCORPORACIÓN DEL AISLAMIENTO ACÚSTICO NI SOLERA FLOTANTE



BOM ISOLAMENTO TÉRMICO
 GOOD THERMAL INSULATION
BONNE ISOLATION THERMIQUE
 BUENO AISLAMIENTO TÉRMICO



IDEAL PARA REMODELAÇÕES
 IDEAL FOR REMODELLING
IDÉAL POUR LES TRANSFORMATIONS
 IDEAL PARA REMODELACIONES



REDUZ O TEMPO DE OBRA E OS CUSTOS DE APLICAÇÃO
 REDUCES WORKING TIME AND CUTTING APPLICATION COSTS
RÉDUIT LE TEMPS DE CHANTIER ET LES COÛTS D'APPLICATION
 REDUCE EL TIEMPO DE OBRA Y REDUCE LOS COSTES DE APLICACIÓN



INOVADOR E ECO EFICIENTE
 INNOVATIVE AND ECO-EFFICIENT
INNOVATEUR AND ÉCO-EFFICIENT
 INNOVADOR Y ECOEFICIENTE



COMPENSA AS FALHAS DE ISOLAMENTO ACÚSTICO NOS EDIFICADOS ANTIGOS
 SOLVES IMPACT NOISE INSULATION FAILURES IN OLDER BUILDINGS
RÉSOUT LES PROBLÈMES D'ISOLATION CONTRE LES BRUITS D'IMPACT QUI EXISTENT DANS LES ÉDIFICES LES PLUS ANCIENS
 RESUELVE LOS PROBLEMAS DE AISLAMIENTO DEL RUIDO DE IMPACTO QUE EXISTEN EN LOS EDIFICIOS MÁS ANTIGUOS



ABSORÇÃO DE SONS E AMORTECIMENTO DAS VIBRAÇÕES
 CAPACITY FOR ABSORBING SOUNDS AND DAMPENING VIBRATIONS
ABSORPTION DES SONS ET AMORTISSEMENT DES VIBRATIONS
 ABSORCIÓN DE SONIDOS Y AMORTIGUACIÓN DE LAS VIBRACIONES



SENSAÇÃO DE CONFORTO
 SENSATION OF COMFORT
SENSATION CONFORTABLE
 SENSACIÓN CÓMODA

no buttons, no keys

Cerâmica sensitiva: sem botões, sem teclas
superfícies cerâmicas funcionais para domótica

Sensitive ceramics: no buttons, no keys
 functional ceramic surfaces for home automation

Céramique sensitive: pas de boutons, pas de touches
surfaces céramiques fonctionnelles pour la domotique

Cerámica sensible: sin botones, sin teclas
 superficies cerámicas funcionales para domótica

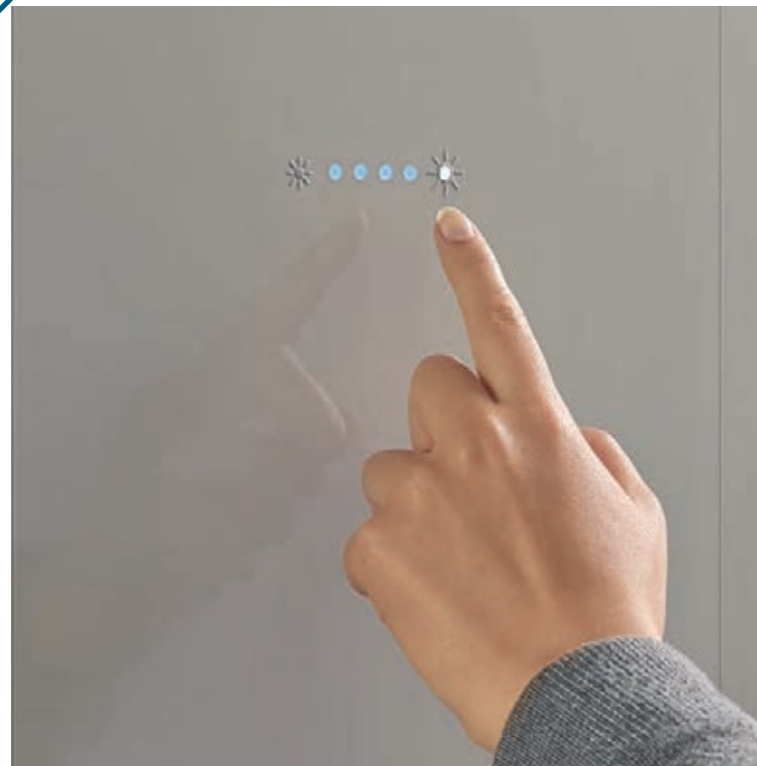

Sensor com dimmer _ Sensor with dimmer
 Capteur avec variateur _ Sensor con regulador de intensidad

REVISENSE

Esta solução pode ser produzida, sob encomenda, para várias coleções de grés porcelânico (exceto coleção Espelho/Mirror), em vários efeitos e texturas. Solicitamos consulta específica ao Departamento Comercial.

Instalação: consulte a página 411 deste catálogo.

REVISENSE

This solution can be produced on request for various collections full body porcelain (except Espelho/Mirror collection) in several effects and textures. We recommend you address your special request with the Commercial Department.

Installation: see page 411 of this catalogue.



Sensor com ON/OFF _ Sensor with ON/OFF
 Capteur avec ON/OFF _ Sensor con ON/OFF

REVISENSE

Cette solution peut être produite, sur commande, pour différentes collections grés cérame (sauf collection Espelho/Mirror), en différents effets et textures. Nous demandons une consultation spécifique avec le Département Commercial.

Installation : veuillez consulter la page 411 de ce catalogue.

REVISENSE

Esta solución puede realizarse, bajo petición, para varias colecciones en grés porcelánico (excepto colección Espelho/Mirror), en diferentes efectos y texturas. Para más información, consulte con el Departamento Comercial.

Instalación: consulte la página 411 de este catálogo.

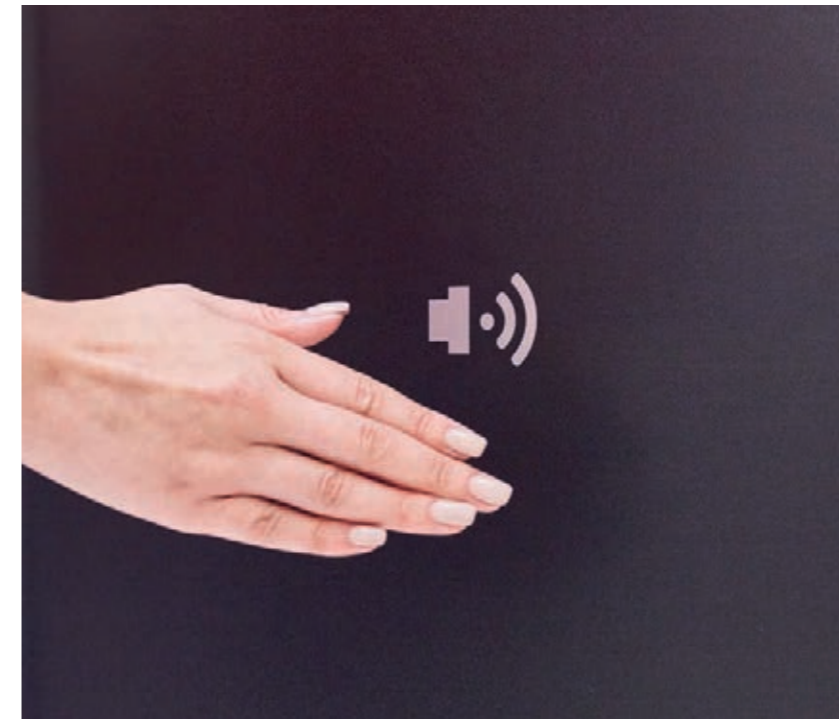

Sensor com campainha _ Sensor with bell
 Capteur avec cloche _ Sensor con campana

Vantagens _ Advantages _ Avantages _ Ventajas:

- MAIOR HIGIENE PARA O UTILIZADOR**
 Evita a propagação de bactérias em espaços públicos
 GREATER HYGIENE FOR THE USER
 Avoids propagation of bacteria in public spaces
PLUS GRANDE HYGIÈNE POUR L'UTILISATEUR
 Évite la propagation de bactéries dans les lieux publics
 MAYOR HIGIENE PARA EL USUARIO
 Evita la propagación de bacterias en espacios públicos
- DESIGN INCLUSIVO - MAIOR ACESSIBILIDADE E CONFORTO**
 para pessoas com motricidade e mobilidade reduzida, invisuais ou amblíopes
 INCLUSIVE DESIGN - GREATER ACCESSIBILITY AND COMFORT
 for people with reduced mobility and motricity, blind or partially sighted
DESIGN INCLUSIF - PLUS GRANDE ACCESSIBILITÉ ET PLUS GRAND CONFORT
 pour les personnes à motricité et mobilité réduites, aveugles et amblyopes
 IDISEÑO INTEGRADOR - MAYOR ACCESIBILIDAD Y CONFORT
 para personas con movilidad reducida, con visión reducida o invidentes
- MAIOR SEGURANÇA E MAIOR ABRANGÊNCIA NA UTILIZAÇÃO:**
 As propriedades da cerâmica, aliadas à baixa tensão do sistema, permitem a instalação em locais interditos à aparelhagem elétrica tradicional (Ex. zonas húmidas)
 GREATER SAFETY AND WIDER RANGE OF INSTALLATION SITES:
 The properties of ceramics, combined with the low voltage system, allow for installation in locations which are off-limits for traditional electrical apparatus (e.g. damp areas).
UTILISATION PLUS SÛRE ET PLUS VASTE:
 Les propriétés de la céramique, alliées à la faible tension du système, permettent l'installation dans des lieux interdits au matériel électrique traditionnel (par exemple dans les zones humides)
 MAYOR SEGURIDAD Y CAPACIDAD DE USO:
 Las propiedades de la cerámica, junto con una baja tensión del sistema, permiten la instalación en lugares normalmente restringidos para los elementos eléctricos tradicionales (Ej. zonas húmedas)
- MAIOR INTEGRAÇÃO ARQUITETÓNICA**
 GREATER ARCHITECTURAL INTEGRATION
 UNE INTEGRATION ARCHITECTURALE MAXIMALE
 MAYOR INTEGRACIÓN ARQUITECTÓNICA
- FÁCIL DE INSTALAR**
 EASY TO INSTALL
 FACILE À POSER
 FÁCIL DE COLOCAR
- MAIOR RESISTÊNCIA AO DESGASTE**
 HIGH RESISTANCE TO USE
 HAUTE RÉSIDENCE A L'USURE
 ALTA RESISTENCIA AL DESGASTE
- FÁCIL LIMPEZA E MANUTENÇÃO**
 EASY CLEANING AND MAINTENANCE
 NETTOYAGE ET ENTRETIEN FACILE
 FÁCIL LIMPIEZA Y MANTENIMIENTO

Tektónica:
Prémio Inovação
 Innovation Award

Prémio Inovação na
Construção
 Innovation in
 Construction Award

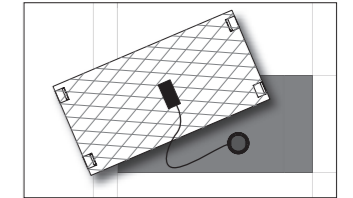

MATT RECT · RECT · SOFT · LAP · POL
 todos os formatos_all formats

Incorporação de sensor não visível sob
superfícies cerâmicas.

Built-in, non-visible sensor
 under ceramic surfaces.

Incorporation d'un capteur invisible sous
des surfaces céramiques.

Sensor oculto bajo
 superficies cerámicas.

Revestimento e pavimento antibacteriano
Antibacterial wall and floor tile
Muraux et revêtements de sol antibactérien
Revestimiento y pavimento antibacteriano

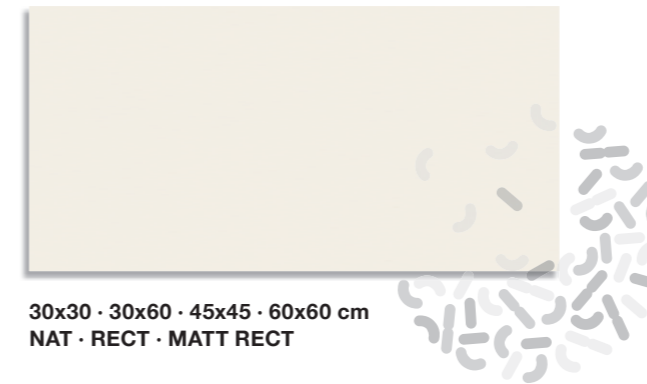

30x30 · 30x60 · 45x45 · 60x60 cm
 NAT · RECT · MATT RECT





Ensaio em laboratório
 (nanobiomatters/norma ISO 27447)



Laboratory test
 (Nanobiomatters/Standard ISO 27447)

Essai en laboratoire
 (Nanobiomatters/Norme ISO 27447)

Pruebas en laboratorio
 (Nanobiomatters/Norma ISO 27447)

Vantagens _ Advantages _ Avantages _ Ventajas:

- 
ELIMINA 99,99% DAS BACTÉRIAS MAIS PERIGOSAS EM CONTACTO COM O PRODUTO
ELIMINATES 99.99% OF THE MOST DANGEROUS BACTERIA
ÉLIMINE 99,99 % DES BACTÉRIES LES PLUS DANGEREUSES
ELIMINA EL 99,99% DE LAS BACTERIAS MÁS PELIGROSAS
- 
ANTIBACTERIANO DE ÚLTIMA GERAÇÃO
DESENVOLVIDO ESPECIFICAMENTE PARA A CERÂMICA
THE LATEST GENERATION OF ANTIBACTERIAL PRODUCTS
WAS SPECIFICALLY DEVELOPED FOR CERAMIC TILES
ANTIBACTÉRIEN DE DERNIÈRE GÉNÉRATION
DÉVELOPPÉ SPÉCIFIQUEMENT POUR LA CÉRAMIQUE
ANTIBACTERIANO DE ÚLTIMA GENERACIÓN
DESARROLLADO ESPECIFICAMENTE PARA LA CERÁMICA
- 
REDUZ OS RISCOS DE CONTAMINAÇÃO
REDUCES CONTAMINATION RISKS
RÉDUIT LES RISQUES DE CONTAMINATION
REDUCE LOS RIESGOS DE CONTAMINACIÓN

- 
CONFERE MAIS HIGIENE AOS LOCAIS PÚBLICOS E AMBIENTES DOMÉSTICOS
IT AFFORDS GREATER HYGIENE TO PUBLIC PLACES AND HOUSEHOLD ENVIRONMENTS
CONFÈRE UNE PLUS GRANDE HYGIÈNE AUX LIEUX PUBLICS ET AUX ENVIRONNEMENTS DOMESTIQUES
OTORGA UNA MAYOR HIGIENE EN LOS LUGARES PÚBLICOS Y A LOS AMBIENTES DOMÉSTICOS
- 
EFICÁCIA DURADOURA E PERMANENTE
EFFECTIVE, LONG-LASTING SOLUTION
SOLUTION EFFICACE ET DURABLE
SOLUCIÓN EFICAZ Y DURADERA
- 
ANTIBACTERIANO COM A DURAÇÃO DA VIDA ÚTIL DO PRODUTO
IT LENGTHENS THE WORKING LIFE OF THE PRODUCT
L'ANTIBACTÉRIEN A LA DURÉE DE LA VIE UTILE DU PRODUIT
EL ANTIBACTERIANO TIENE LA DURACIÓN DE LA VIDA ÚTIL DEL PRODUCTO

REVICARE
 O esmalte que integra a composição de REVICARE interrompe o funcionamento biológico das bactérias. Quando entram em contacto com o produto, as bactérias não se desenvolvem nem se reproduzem, terminando o seu ciclo de vida.

REVICARE
 The enamel in the composition of REVICARE interrupts the biological functioning of bacteria. When they come into contact with the product, the bacteria don't grow nor reproduce, ending their lifecycle.

REVICARE
 L'émail qui fait partie de la composition de REVICARE interrompt le fonctionnement biologique des bactéries. Lorsqu'elles entrent en contact avec le produit, les bactéries ne se développent et ne se reproduisent pas, mettant fin à leur cycle de vie.

REVICARE
 El esmalte que forma parte de la composición de REVICARE interrumpe la actividad biológica de las bacterias. Cuando entran en contacto con el producto, las bacterias no se desarrollan ni se reproducen, terminando su ciclo de vida.

Se fabrica por encargo. Los pedidos están sujetos a cantidades mínimas. Para más información, consulte con el Departamento Comercial.

É produzido sob encomenda, estando sujeito a quantidades mínimas. Solicitamos consulta específica ao Departamento Comercial.

It is produced to order, being subject to minimum quantities. We recommend you address your special request with the Commercial Department.

Il est produit sur commande, étant soumis à des quantités minimales. Nous demandons une consultation spécifique avec le Département Commercial.

Deck cerâmico em pavimento sobrelevado Ceramic deck on raised floor Deck céramique en plancher surélevé Deck cerâmico en suelos elevados



Deck cerâmico de fácil encaixe adequado para aplicação em piso sobrelevado. Aplicação através do encaixe das peças e fixação com linguetas à estrutura. Removível: facilita a substituição de peças e o fácil acesso a sistemas ocultos. Adequado para espaços exteriores e aplicável em vários tipos de piso: asfaltos, betão, compostos, madeiras e isolamentos, entre outros.

As características técnicas do grés porcelânico técnico tornam este sistema mais seguro, eliminando a frequente deterioração, em farpas, do deck em madeira. Além disso, o DECK SMART não necessita da manutenção anual exigida pelo deck convencional, dispensando os custos e obras inerentes.

Peças: consulte a página 330 deste catálogo.
Instalação: consulte a página 412 deste catálogo.

Ceramic deck easy to install suitable for raised floors. Application by slotting in pieces and affixing with bolts onto the structure. Removable: this facilitates the replacement of pieces and easy access to concealed systems. Perfect for outdoor and can be applied to a variety of floors: asphalt, concrete, compounds, wood and insulation, among others.

The technical features of full body porcelain tiles make this system safer, avoiding the frequent splintering of traditional wooden deck. Furthermore, DECK SMART does not require annual maintenance as is the case of conventional deck, eliminating the respective costs and maintenance works.

Pieces: see page 330 of this catalogue.
Installation: see page 412 of this catalogue.

Deck céramique à emboîtement facile approprié pour les applications sur planchers surélevés. Application par l'emboîtement de pièces et la fixation de languettes sur la structure. Amovible: facilite le remplacement de pièces ainsi que l'accès aux systèmes cachés. Approprié pour les espaces extérieurs et peut être appliqué sur différents types de sol : asphalte, béton, composite, bois et matériaux d'isolation, entre autres.

Les caractéristiques techniques du grés cérame pleine masse rendent ce système plus sûr, en évitant la détérioration fréquente en éclats de bois du deck traditionnel. De plus, le DECK SMART ne nécessite pas l'entretien annuel requis par le deck conventionnel, évitant ainsi les frais et les travaux qui en découlent.

Pièces : veuillez consulter la page 330 de ce catalogue.
Installation : veuillez consulter la page 412 de ce catalogue.

Deck cerâmico de fácil colocación, adecuado para su aplicación en suelo elevado. Se fabrica por encargo. Aplicación mediante encaje de piezas y fijación con lengüetas sobre la estructura. Extraíble: facilita la sustitución de piezas y el fácil acceso a sistemas ocultos. Adecuado para espacios exteriores y se puede aplicar a varios tipos de suelo (asfaltos, hormigón, compuestos, maderas y aislamientos, entre otros).

Las características técnicas del grés porcelânico técnico proporcionan mayor seguridad a este sistema, evitando el deterioro frecuente en astillas del tradicional deck de madera. Además, DECK SMART no necesita el mantenimiento anual que requiere el deck convencional, eliminando los gastos y las obras inherentes.

Piezas: consulte la página 330 de este catálogo.
Instalación: consulte la página 412 de este catálogo.

ESTRUTURA DE SUPORTE

Deverá ser escolhido o material (alumínio ou madeira) que melhor se adequa às características do espaço e da obra. É recomendável a estrutura em alumínio por ser mais duradoura. Quantidade necessária: 3,5 ml por cada m² de pavimento. A estrutura deverá apoiar o Deck em 3 ou 4 pontos da peça – extremidades e centro – de acordo com a intensidade do tráfego do espaço. Em áreas planas, sem desníveis, a estrutura de suporte poderá ser apoiada diretamente sobre o piso.

SUPPORT STRUCTURE

Choose the support structure material, aluminium or wood, that is most appropriate for the characteristics of the space and project. The aluminium structure is recommended as it is longer-lasting. Amount required: 3.5 ml per sq.m of floor. The structure must support the Deck in 3 or 4 points – edges and middle – depending on the amount of traffic in the area. On flat, levelled floors, the support structure may be laid directly on the ground.

STRUCTURE PORTANTE

Il faut choisir le matériau (aluminium ou bois) qui convient le mieux aux caractéristiques de l'espace et du chantier. Une structure en aluminium est conseillée car elle est plus durable. Quantité requise: 3,5 ml par m² de plancher. La structure devra porter le Deck sur 3 ou 4 points d'appui de la pièce – extrémités et milieu – selon l'intensité de circulation dans l'espace. Dans les surfaces plates, sans pente, la structure portante peut s'appuyer directement sur le sol.

ESTRUCTURA DE SOPORTE

Deberá elegirse el material (aluminio o madera) que mejor se adapte a las características del espacio y de la obra. Se recomienda la utilización de estructuras de aluminio por ser más duraderas. Cantidad necesaria: 3,5 ml por cada m² de pavimento. La estructura deberá apoyar el deck en 3 o 4 puntos de la pieza (las extremidades y el centro) de acuerdo con la intensidad del tráfico del espacio. Áreas planas, sin desniveles, la estructura de soporte podrá apoyarse directamente sobre el suelo.

LINGUETA DE FIXAÇÃO

23 linguetas por cada m² de pavimento. Facilitam a aplicação desta solução e garantem um distanciamento perfeito e uniforme em toda a obra: aproximadamente 9 mm de junta entre peças.

ANCHORING BOLT

23 bolts per sq.m of floor. To help installing this solution and guarantee a perfect and uniform spacing in all the work: an approximately 9 mm joint between pieces.

LANGUETTE DE FIXATION

23 languettes par m² de plancher. Facilitent la mise en place de cette solution et garantissent un espacement parfait et uniforme par tout: 9 mm environ de joint entre les pièces.

LENGÜETA DE FIJACIÓN

23 lengüetas por cada m² de pavimento. Facilitan la aplicación de esta solución y garantizan un distanciamiento perfecto y uniforme en toda la obra: aproximadamente 9 mm de junta entre piezas.

Vantagens _ Advantages _ Avantages _ Ventajas:

 **FÁCIL ENCAIXE E SUBSTITUIÇÃO (COR REPRODUTÍVEL)**
EASY INSTALLATION AND REPLACEMENT (REPRODUCIBLE COLOUR)
EMBOÏTAGE ET REMPLACEMENT FACILES (COULEUR REPRODUCTIBLE)
FÁCIL COLOCACIÓN Y SUSTITUCIÓN (COLOR REPRODUCIBLE)

 **ELEVADA RESISTÊNCIA AO ESCORREGAMENTO**
HIGH ANTI SLIP RESISTANCE
AUTE RÉSIDENCE À LA GLISSANCE
ALTA RESISTENCIA ANTIDESLIZAMIENTO

 **OCULTAÇÃO DE CABOS E TUBAGENS**
CONCEALMENT OF CABLES AND PIPES
OCCULTATION DE CABLES ET TUYAUTERIES
OCULTACIÓN DE CABLES Y TUBOS

 **ELEVADA RESISTÊNCIA AO DESGASTE**
HIGH RESISTANCE TO USE
HAUTE RÉSIDENCE A L'USURE
ALTA RESISTENCIA AL DESGASTE

 **NÃO DEFORMA AO LONGO DO TEMPO**
DOES NOT WARP OVER TIME
IL NE SE DÉFORME PAS AU FIL DU TEMPS
NO SE DEFORMA CON EL PASO DEL TIEMPO

 **ELEVADA RESISTÊNCIA ÀS MANCHAS E A QUÍMICOS.**
Solventes orgânicos, soluções aquosas inorgânicas, ácidos e alcalis, detergentes e lixívia, fungos, mofo e bactérias
HIGH RESISTANCE TO STAINING AND CHEMICALS.
Organic solvents, inorganic water-based solutions, acids and alkalis, detergents and bleaches, fungi, moulds and bacteria
UNE HAUTE RÉSIDENCE AUX TACHES ET AUX SUBSTANCES CHIMIQUES.
Solvants organiques, solutions aqueuses inorganiques, acides et alcalins, détergents et eaux de javel, champignons, moisissures et bactéries
ALTA RESISTENCIA A LAS MANCHAS Y A LOS PRODUCTOS QUÍMICOS.
Disolventes orgânicos, soluciones acuosas inorgânicas, ácidos y bases, detergentes y lejías, hongos, moho y bacterias

 **ELEVADA RESISTÊNCIA AO IMPACTO**
HIGH RESISTANCE TO IMPACT
HAUTE RÉSIDENCE A L'IMPACT
ALTA RESISTENCIA AL IMPACTO

 **RESISTÊNCIA A AMPLITUDES TÉRMICAS (-25°C/ +110°C)**
RESISTANCE TO THERMAL VARIATIONS (-25°C/ +110°C)
RÉSISTANCE AUX AMPLITUDES THERMIQUES (-25°C/ +110°C)
RESISTENCIA A AMPLITUDES TÉRMICAS (-25°C/ +110°C)

 **FÁCIL LIMPEZA E MANUTENÇÃO**
EASY CLEANING AND MAINTENANCE
NETTOYAGE ET ENTRETIEN FACILE
FÁCIL LIMPIEZA Y MANTENIMIENTO

 **BOM ISOLAMENTO: Ventilação eficiente através de uma câmara-de-ar**
GOOD INSULATION: Efficient ventilation by means of air chamber
BONNE ISOLATION : Aération efficace grâce à une chambre à air
BUEN AISLAMIENTO: Ventilación eficiente mediante una cámara de aire

 **FACILIDADE NA DRENAGEM DE ÁGUAS**
EASY WATER DRAINAGE
FACILITÉ DE DRAINAGE DES EAUX
FACILIDAD EN EL DRENAJE DE AGUAS

 **NÃO CONTÉM MATERIAIS NOCIVOS PARA A SAÚDE, evitando a contaminação dos solos.**
CONTAINS NO MATERIAL HARMFUL TO THE HEALTH, thus avoiding soil contamination.
IL NE CONTIENT AUCUN MATÉRIEL NOCIF POUR LA SANTÉ, évitant la contamination du sol.
NO CONTIENE MATERIALES NOCIVOS PARA LA SALUD, evitando así la contaminación del suelo.

Ventilated Façades

Fachadas Ventiladas:

Solução estética e funcional para maior eficiência energética dos edifícios

Ventilated Façades:

Aesthetic and functional solution for improved building's energy efficiency

Façades Ventilées:

Solution esthétique et fonctionnelle pour une amélioration de l'efficacité énergétique des bâtiments

Fachadas Ventiladas:

Solución estética y funcional para una mayor eficiencia energética de los edificios



Edifício de escritórios Panoramic Expo _ Lisboa, Portugal
Panoramic Expo Office Building _ Lisbon, Portugal

FACHADA COLADA
FAÇADE USING ADHESIVES
FAÇADE COLLÉE
FACHADA PEGADA

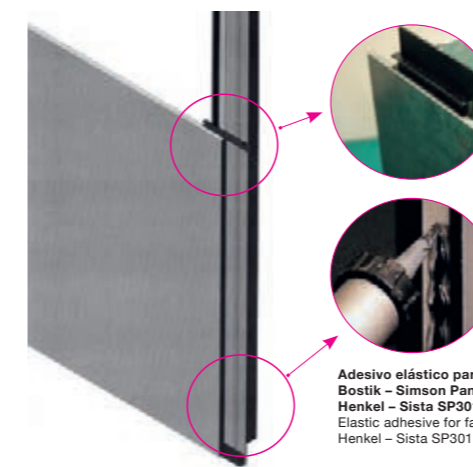

Adesivo elástico para fachada:
Bostik – Simson Paneltack HM;
Henkel – Sista SP301 Façades
Elastic adhesive for façade:
Henkel – Sista SP301 Façades

FACHADA COM GRAMPO OCULTO
FAÇADE USING HIDDEN FASTENERS
FAÇADE AGRAFÉE AVEC AGRAFE OCCULTE
FACHADA CON GRAPA OCULTA

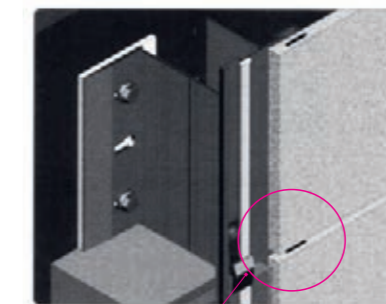

Peça Cerâmica com ranhura
Ceramic piece with slit
Pièce céramique avec rainure
Pieza Cerámica con ranura

FACHADA COM GRAMPO À VISTA
FAÇADE USING VISIBLE FASTENERS
FAÇADE AGRAFÉE AVEC AGRAFE APPARENTE
FACHADA CON GRAPA A LA VISTA

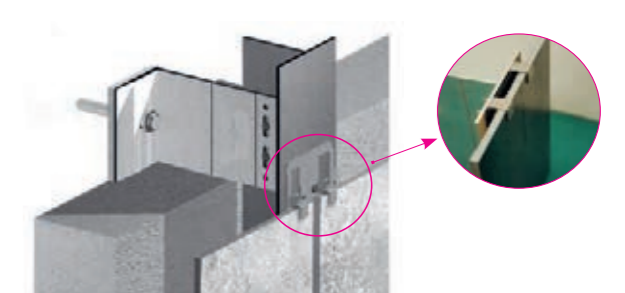

Vantagens _ Advantages _ Avantages _ Ventajas:



ADEQUADO PARA REABILITAÇÕES:
APLICÁVEL SOBRE QUALQUER SUPORTE EXISTENTE
SUITABLE FOR REHABILITATIONS:
APPLICABLE OVER ANY TYPE OF STRUCTURE
ADÉQUAT POUR LES RÉHABILITATIONS:
APPLICABLE SUR TOUT SUPPORT EXISTANT
ADECUADO PARA REHABILITACIONES:
APLICABLE SOBRE CUALQUIER SOPORTE EXISTENTE



RÁPIDA EXECUÇÃO E GARANTIA DE
SEGURANÇA NA UTILIZAÇÃO
QUICK SET UP AND GUARANTEED SAFE USE
RAPIDITÉ D'EXÉCUTION ET GARANTIE DE
SÉCURITÉ LORS DE L'UTILISATION
RÁPIDA EJECUCIÓN Y GARANTIA DE
SEGURIDAD EN EL USO



VENTILAÇÃO EFICAZ: EVITA O APARECIMENTO DE HUMIDADE
EFFICIENT VENTILATION: PREVENTS MOLD INFESTATION
VENTILATION EFFICACE: IL ÉVITE L'APPARITION D'HUMIDITÉ
VENTILACIÓN EFICAZ: EVITA LA APARICIÓN DE HUMEDAD



BOM ISOLAMENTO TÉRMICO DOS EDIFÍCIOS
GOOD THERMAL INSULATION IN BUILDINGS
BONNE ISOLATION THERMIQUE DES BÂTIMENTS
BUENO AISLAMIENTO TÉRMICO DE LOS EDIFICIOS



AUSÊNCIA DE CONDENSAÇÕES E AUSÊNCIA DE EFLORESCÊNCIAS
NO CONDENSATION AND NO EFFLORESCENCE
ABSENCE DE CONDENSATION ET ABSENCE D'EFFLORESCENCES
AUSENCIA DE CONDENSACIÓN Y AUSENCIA DE EFLORESCENCIAS



ACESSO RÁPIDO EM CASO DE MANUTENÇÃO OU REPARAÇÃO
QUICK ACCESS FOR MAINTENANCE OR REPAIR WORK
ACCÈS RAPIDE EN CAS D'ENTRETIEN OU RÉPARATION
ACCESO RÁPIDO EN CASO DE MANTENIMIENTO O REPARACIÓN

Existem diversas empresas que executam o projeto e a aplicação de fachadas ventiladas. No entanto, no caso de ser necessária alguma informação adicional, solicitamos o contacto para: revigres@revigres.pt

There are several companies that accomplish the project and the application of ventilated façades. For more information please contact us at: revigres@revigres.pt

Il y a diverses sociétés qu'exécutent le projet et l'application des façades ventilées. Toutefois, pour toutes informations complémentaires, la direction technique reste à votre disposition. Contactez-nous à: revigres@revigres.pt

Existen diversas empresas que realizan el proyecto y la aplicación de fachadas ventiladas. Sin embargo, en caso de que sea necesaria alguna información adicional, le recomendamos que contacte con: revigres@revigres.pt

Antiderrapantes Antislip

Aumentamos a sua segurança através de diferentes níveis de resistência ao deslizamento.

We increase your safety through different levels of slip resistance.

Nous augmentons votre sécurité grâce à différents niveaux de résistance au glissement.

Aumentamos su seguridad a través de diferentes niveles de resistencia al deslizamiento.



Deck Teca
Condomínio Olivais Residence, Coimbra, Portugal
Olivais Residence Condominium, Coimbra, Portugal

PRODUTOS QUE MINIMIZAM O RISCO DE DESLIZAMENTO:
PRODUCTS THAT MINIMIZE THE RISK OF SLIPPING:
PRODUITS QUI RÉDUISENT LE RISQUE DE GLISSEMENT:
PRODUCTOS QUE MINIMIZAN EL RIESGO DE DESLIZAMIENTO:



PRODUTOS ESTRUTURADOS:
ECOTECH (Class 2; R10); FLINT ESTR (Class 3; R11)

STRUCTURED PRODUCTS:
ECOTECH (Class 2; R10); FLINT ESTR (Class 3; R11)

PRODUITS STRUCTURÉS:
ECOTECH (Class 2; R10); FLINT ESTR (Class 3; R11)

PRODUCTOS ESTRUCTURADOS:
ECOTECH (Class 2; R10); FLINT ESTR (Class 3; R11)



PRODUTOS ANTIDERRAPANTES:
JAVA / DECK (Class 3, R11); ANTIDERRAPANTE SATURNO (Class 3; R12); DECK FOREST (Class 3, R13)

ANTISLIP PRODUCTS:
JAVA / DECK (Class 3, R11); ANTIDERRAPANTE SATURNO (Class 3; R12); DECK FOREST (Class 3, R13)

PRODUITS ANTIDÉRAPANTS:
JAVA / DECK (Class 3, R11); ANTIDERRAPANTE SATURNO (Class 3; R12); DECK FOREST (Class 3, R13)

PRODUCTOS ANTIDESLIZANTES:
JAVA / DECK (Class 3, R11); ANTIDERRAPANTE SATURNO (Class 3; R12); DECK FOREST (Class 3, R13)



PRODUTOS ANTISLIP:
PIGMENTO, GLOBE, URBAN, CITYZEN, ELEMENTS, AFYON, LAVASTONE, FOREST (Class 3, R11); SLATE (Class 3, R12)

ANTISLIP PRODUCTS:
PIGMENTO, GLOBE, URBAN, CITYZEN, ELEMENTS, AFYON, LAVASTONE, FOREST (Class 3, R11); SLATE (Class 3, R12)

PRODUITS ANTISLIP:
PIGMENTO, GLOBE, URBAN, CITYZEN, ELEMENTS, AFYON, LAVASTONE, FOREST (Class 3, R11); SLATE (Class 3, R12)

APRODUCTOS ANTISLIP:
PIGMENTO, GLOBE, URBAN, CITYZEN, ELEMENTS, AFYON, LAVASTONE, FOREST (Class 3, R11); SLATE (Class 3, R12)

Antislip

ENV 12633	DIN 51130
class 3	R11

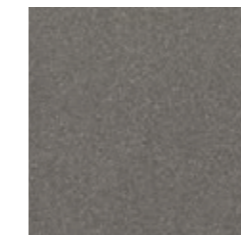

Pigmento Antislip
pag. 80



Antislip Forest
pag. 334



Antislip Urban
pag. 212

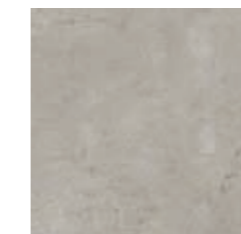

Antislip Globe
pag. 206



Elements Antislip
pag. 172

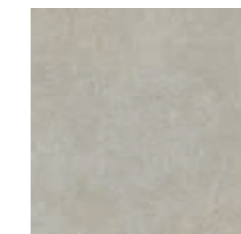

Cityzen Antislip
pag. 164

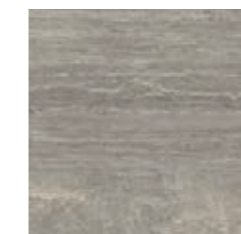

Antislip Afyon
pag. 266



Lavastone Antislip
pag. 274



Slate Antislip
pag. 286



Estruturado Structured

ENV 12633	DIN 51130
class 2	R10



Ecotech
pag. 88

Estruturado Structured

ENV 12633	DIN 51130
class 3	R11



Flint
pag. 56

Antiderrapantes

ENV 12633	DIN 51130
class 3	R11



Antiderrapante Saturno
pag. 92

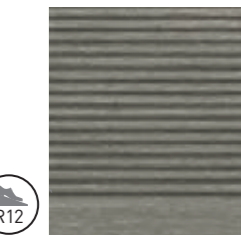

Deck
pag. 326

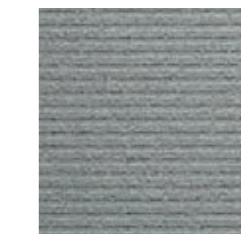

Java
pag. 84



Deck Forest
pag. 338



Projects

A partner for your project

Um parceiro para o seu projeto
Un partenaire pour votre projet
Un socio para su proyecto

Identifique o seu projeto com a nossa marca, personalizando a sua obra com o logotipo Revigrés. Para mais informações, por favor, contacte-nos através da nossa equipa comercial ou do email revigrés@revigrés.pt.

Identify your project with our brand by customizing it with the Revigrés logo. For more information please contact our sales team or send an email to revigrés@revigrés.pt.

Identifiez votre projet avec notre marque, en personnalisant votre travail avec le logo Revigrés. N'hésitez pas à nous contacter pour tout renseignement complémentaire à travers notre équipe commerciale ou par e-mail à revigrés@revigrés.pt.

Identifique su proyecto con nuestra marca, personalizando su obra con el logotipo Revigrés. Para más información, póngase en contacto con nosotros a través de nuestro equipo comercial o de la dirección de correo electrónico revigrés@revigrés.pt.

Projetos _ Projects



Dê largas à sua imaginação e experimente aplicar as peças de cerâmica da Revigrés nas mais diversas superfícies. Apresentamos algumas sugestões.

Let your imagination run wild and try using Revigrés tiles on a wide range of surfaces. Here are some suggestions.

Laissez libre cours à votre imagination et essayez d'appliquer les carreaux de céramique Revigrés sur les surfaces les plus variées. Ci-après quelques suggestions.

Deje volar su imaginación y pruebe a aplicar las baldosas cerámicas Revigrés en las superficies más diversas. Le presentamos algunas sugerencias.

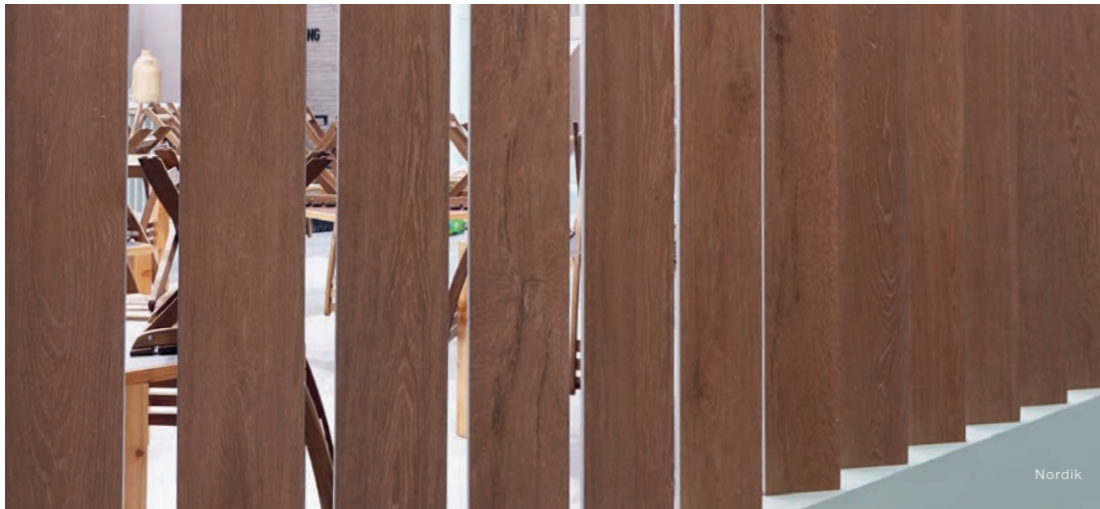

Identifique o seu projeto com a nossa marca, personalizando a sua obra com o logotipo Revigrés. Para mais informações, por favor, contacte-nos através da nossa equipa comercial ou do email revigrés@revigrés.pt.

Identify your project with our brand by customizing it with the Revigrés logo. For more information please contact our sales team or send an email to revigrés@revigrés.pt.

Identifiez votre projet avec notre marque, en personnalisant votre travail avec le logo Revigrés. N'hésitez pas à nous contacter pour tout renseignement complémentaire à travers notre équipe commerciale ou par e-mail à revigrés@revigrés.pt.

Identifique su proyecto con nuestra marca, personalizando su obra con el logotipo Revigrés. Para más información, póngase en contacto con nosotros a través de nuestro equipo comercial o de la dirección de correo electrónico revigrés@revigrés.pt.





Lisboa Racket Center – Alvalade, Portugal
Lisbon Racket Center – Alvalade, Portugal

Cityzen



Perfumes & Companhia – Freefort Alcochete _ Portugal
Perfumes & Companhia – Freefort Alcochete _ Portugal



Banco Santander _ Portugal
Santander Bank _ Portugal

Globe



Farmácia Évora Shopping _ Portugal
Évora Shopping Pharmacy _ Portugal

Lavastone

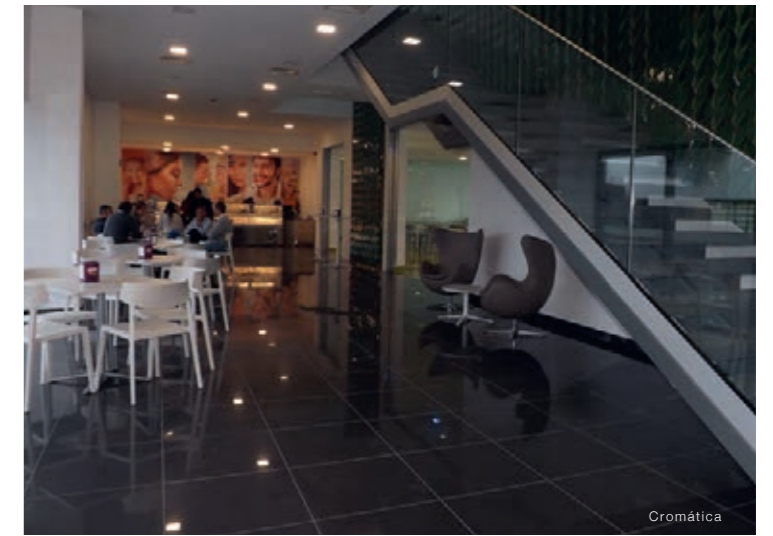

Hospital Particular da Madeira _ Portugal
Hospital Particular da Madeira _ Portugal

Cromática

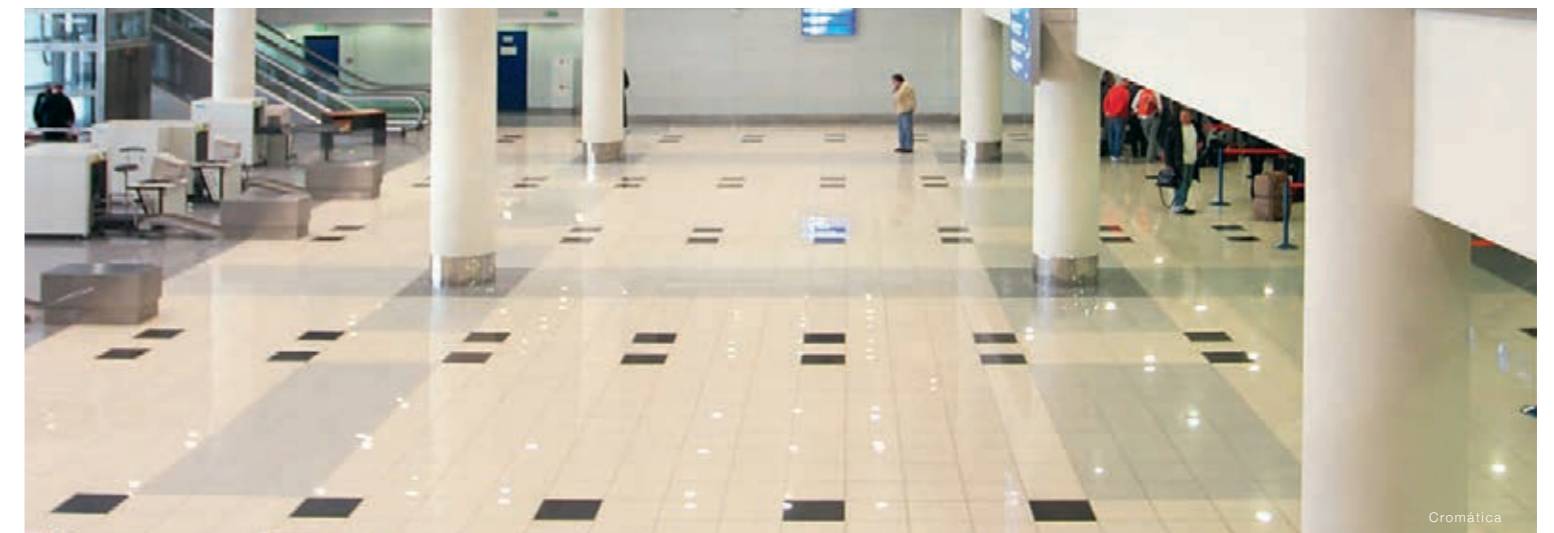

Aeroporto de Vnukovo _ Moscovo, Rússia
Vnukovo Airport _ Moscow, Russia

Cromática

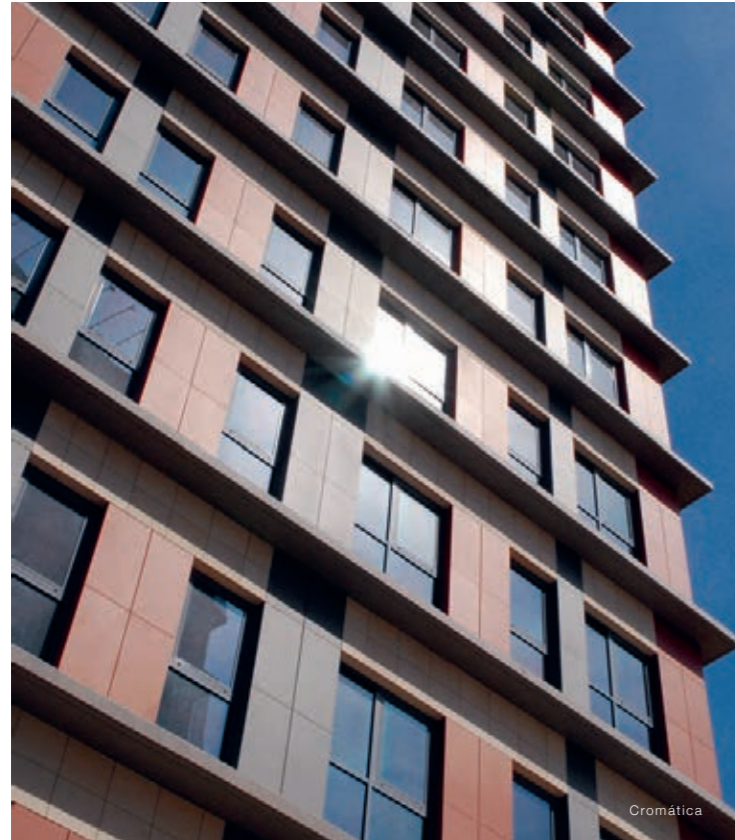

Edifício de escritórios Panoramic Expo _ Lisboa, Portugal
Panoramic Expo Office Building _ Lisbon, Portugal



Computer Stores _ EUA e Canadá
Computer Stores _ USA and Canada



Lojas Fnac – França e Portugal
Fnac Stores – France and Portugal



Sede da Divilux _ Portugal
Divilux Premises _ Portugal



Casino de Valencia - Espanha
Valencia Casino - Spain



Restaurante Steirerck: Duas Estrelas Michelin - Viena, Áustria
Steirerck Restaurant: Two Michelin Stars - Vienna, Austria



Hoteis Do Grupo Vila Galé _ Portugal
Vila Galé Group Hotels _ Portugal



Hotel Maxime _ Lisboa, Portugal
Maxime Hotel _ Lisbon, Portugal

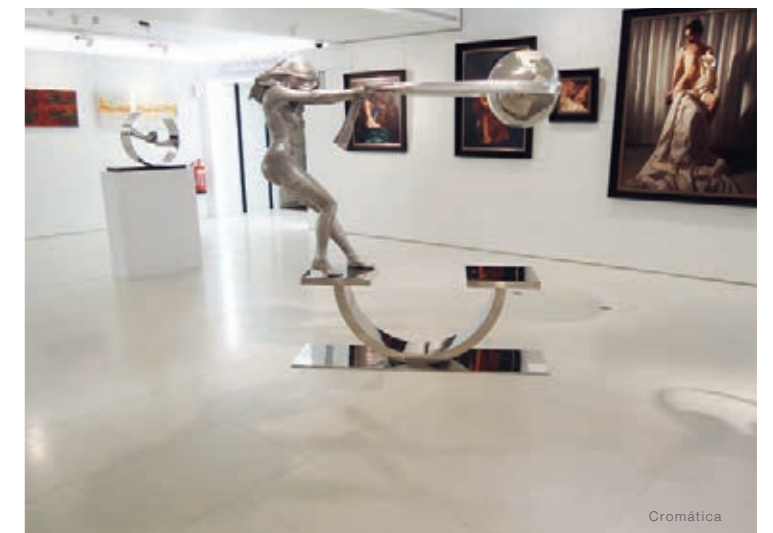

Galeria Harrods _ Londres, Inglaterra
Harrods Gallery _ London, England

Projetos _ Projects

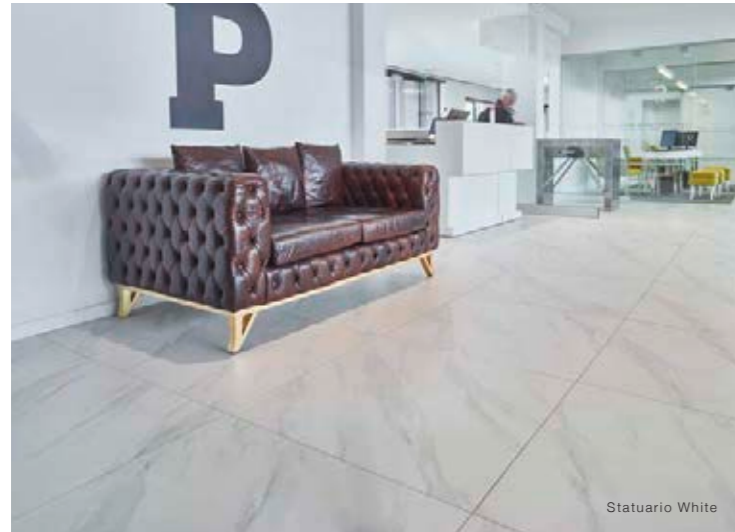

Statuario White

Phive Leiria Health Club _ Coimbra, Portugal
Phive Leiria Health Club _ Coimbra, Portugal



Phive Leiria Health Club _ Leiria, Portugal
Phive Leiria Health Club _ Leiria, Portugal



Restaurantes Panda Express _ EUA e Porto Rico
Panda Express Restaurants _ USA and Puerto Rico



Deck

Farol Design Hotel _ Cascais, Portugal
Farol Design Hotel _ Cascais, Portugal



Stand da Bentley e Rolls Royce _ Leicester, Inglaterra
Bentley and Rolls Royce Car Showroom _ Leicester, England



Deck Teca

Hotel Villa Pampilhosa da Serra _ Portugal
Villa Pampilhosa da Serra Hotel _ Portugal



Exotic

Hotel Star Inn _ Peniche, Portugal
Star Inn Hotel _ Peniche, Portugal



Deck

Centro Comercial Vasco da Gama _ Lisboa, Portugal
Vasco da Gama Shopping Center _ Lisbon, Portugal



Hotel Tivoli Carvoeiro _ Algarve, Portugal
Tivoli Carvoeiro Hotel _ Algarve, Portugal



Deck Wengé

Farol Design Hotel _ Cascais, Portugal
Farol Design Hotel _ Cascais, Portugal



Exotic

Hotel Star Inn _ Peniche, Portugal
Star Inn Hotel _ Peniche, Portugal



Fábrica "Pastéis de Belém" _ Lisboa, Portugal
"Pastéis de Belém" Factory _ Lisbon, Portugal



Sede do Lidl _ Linhó, Portugal
Lidl Headquarters _ Linhó, Portugal



MAR Shopping _ Loulé, Portugal
MAR Shopping Center _ Loulé, Portugal



Park Lake Shopping Center _ Bucareste, Roménia
Park Lake Shopping Center _ Bucharest, Romania



Centro Comercial Alegro _ Setúbal, Portugal
Alegro Shopping Center _ Setúbal, Portugal



Lojas "A Padaria Portuguesa" _ Portugal
"A Padaria Portuguesa" Stores _ Portugal



Trim Towers _ Noruega
Trim Towers _ Norway



Hotel H20 Termal de Unhais da Serra _ Covilhã, Portugal
H20 Medical and Spa Hotel _ Covilhã, Portugal

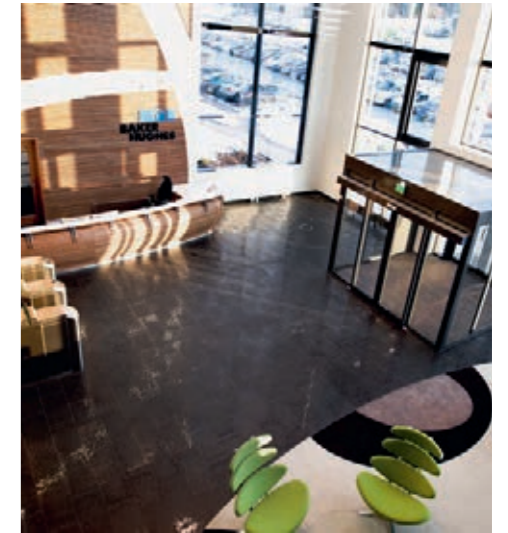

Escritórios Baker Hughes _ Londres e Noruega
Baker Hughes headquarters _ London and Norway



Cella Bar _ Pico, Açores, Portugal
Cella Bar _ Pico, Azores, Portugal



Lojas Fnac _ França e Portugal
Fnac Stores _ France and Portugal



Escritórios Subsea 7 _ Noruega
Subsea 7 Office Building _ Norway



Cinemas _ Warner Lusomundo
Warner Lusomundo _ Cinemas

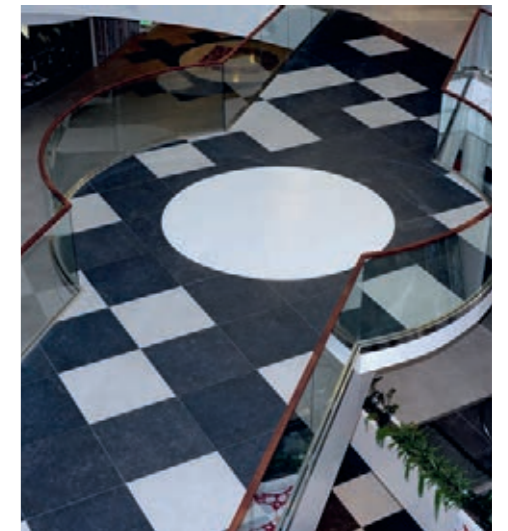

Centro Comercial Narva Astri _ Estónia
Narva Astri Shopping Center _ Estonia

Projetos _ Projects



Estação de Metro "Plaza Elíptica" _ Madrid, Espanha
Plaza Elíptica Underground Station _ Madrid, Spain



Caves Sandeman _ Porto, Portugal
Sandeman Wine-Cellars _ Porto, Portugal



Restaurante McDonald's
McDonald's Restaurant



Escola de Investigação e Ciência _ Dubai, EAU
Research & Science School _ Dubai, UAE



Kitano Clube "Sola" _ Kobe, Japão
Kitano Club "Sola" _ Kobe, Japan



Hospital De Braga _ Portugal
Braga Hospital _ Portugal



Centro Comercial _ Khabarovsk, Rússia
Shopping Center _ Khabarovsk, Russia



Estação de Metro de Jeddah _ Arábia Saudita
Jeddah Underground Station _ Saudi Arabia



Fundação Champalimaud _ Lisboa, Portugal
Champalimaud Foundation _ Lisbon, Portugal



Hotéis do Grupo Vila Galé _ Portugal
Vila Galé Group Hotels _ Portugal



Colégio "Oriente" _ Lisboa, Portugal
"Oriente" College _ Lisbon, Portugal



Hotéis Vila Galé _ Portugal
Vila Galé Hotels _ Portugal

Projetos _ Projects

A sua flexibilidade de produção permite à Revigrés ter uma capacidade impar de resposta para a criação de projetos especiais, personalizados e exclusivos, em áreas interiores e exteriores.

Flexible production grants Revigrés the unique capacity to develop specific, personalised and exclusive projects for indoor and outdoor spaces.

La flexibilité de production de Revigrés lui permet d'avoir une capacité de réponse unique et de créer des projets spéciaux, personnalisés et exclusifs destinés à la fois aux espaces intérieurs et extérieurs.

Su flexibilidad de producción permite a Revigrés tener una capacidad de respuesta excepcional a la hora de crear proyectos especiales, personalizados y exclusivos, tanto para interior como para exterior.



Portas do Mar _ Açores, Portugal
Portas do Mar _ Azores, Portugal



Estádio Municipal Dr Magalhães Pessoa Leiria _ Arq. Tomás Taveira
Dr Magalhães Pessoa Municipal Stadium Leiria _ Tomás Taveira, Architect

Em Portugal, a Revigrés desenvolveu produtos especiais de acordo com os vários projetos apresentados, para diversos estádios do EURO 2004.

In Portugal, Revigrés developed special products for several of the EURO 2004 football stadiums.

Au Portugal, Revigrés a mis au point des produits spéciaux en fonction de différents projets présentés, pour plusieurs stades à l'occasion du championnat de foot : l'EURO 2004.

En Portugal, Revigrés ha desarrollado productos especiales de conformidad con los distintos proyectos presentados para diversos estadios de la EURO 2004.

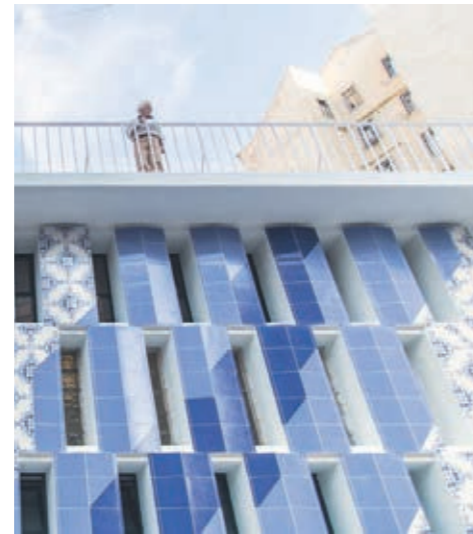
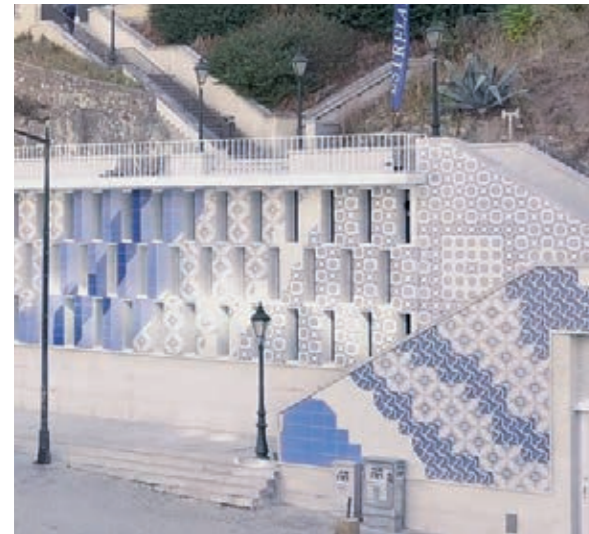

Mural de Azulejos "Louvor da Vivacidade" - Designer Add Fuel (Diogo Machado) _ Lisboa, Portugal
"Louvor da Vivacidade" Tiles Mural - Designer Add Fuel (Diogo Machado) _ Lisbon, Portugal



Estádio Alvalade XXI (Sporting Clube de Portugal) _ Arq. Tomás Taveira
Alvalade XXI Stadium (Sporting Club of Lisbon) _ Tomás Taveira, architect



Estádio Premiado com MEDALHA DE OURO Prémio de Arquitetura Internacional que distingue as melhores Instalações Desportivas Recreativas.
Atribuído pela: Associação Internacional para Equipamentos de Desporto e Lazer (IAKS)
Em colaboração com: Comité Olímpico Internacional

This Stadium was awarded the GOLD MEDAL The International Architecture Prize that distinguishes the best Sports and Leisure Facilities.
From the: International Association for Sports and Leisure Facilities (IAKS)
In collaboration with: International Olympic Committee

Estádio Municipal De Aveiro _ Arq. Tomás Taveira
Aveiro Municipal Stadium _ Tomás Taveira, Architect



Túnel _ Aveiro, Portugal
Tunnel _ Aveiro, Portugal



Estação de Metro das Olaias _ Lisboa, Portugal
Olaias Underground Station _ Lisbon, Portugal



Estádio D. Afonso Henriques (Vitória Sport Clube de Guimarães) _ Arq. Eduardo Guimarães
D. Afonso Henriques Stadium (Vitória Sport Clube de Guimarães) _ Eduardo Guimarães, architect



Painel dos Fundadores Mestre Júlio Resende
Estádio do Dragão (FC Porto)
Founders' Panel Painter Júlio Resende
Dragon Stadium (FC Porto)



Painel Caras _ Estádio do Dragão (FC Porto)
Faces' Panel _ Dragon Stadium (FC Porto)

Useful Information

Informações Úteis
Informations Utiles _ Información Útil

	Página
	Page
	Página
Peças Complementares _ Fittings _ Pieces Speciales _ Piezes Suplementarias	396
Ícones _ Icons _ Icones _ Iconos	398
Acabamento _ Finish _ Finition _ Acabado	402
Calibres _ Calibres _ Calibres _ Calibre	403
Assentamento e Manutenção _ Tile Laying and Maintenance _ Pose et Entretien _ Asentamiento y Mantenimiento	404
Embalagens e Pesos _ Packing List and Weights _ Emballages et Poids _ Embalajes y Pesos	413
Características Técnicas _ Technical Characteristics _ Caractéristiques Techniques _ Características Técnicas	416
Certificados _ Certificates _ Certificats _ Certificados	420

Peças Complementares

Fittings _ Pieces Speciales _ Piezas Suplementarias

FORMATO (cm) SIZE (cm) FORMAT (cm) FORMATO (cm)	COLEÇÃO COLLECTION COLLECTION COLECCIÓN	peça_pieza			
		NAT MATT NAT	RECT SOFT MATT RECT	POL LAP	
15x75 cm	Geral / General / Général / General	P12	-	-	
30x30 [29,6x29,6 cm]	Geral / General / Général / General	P08	P10	P10	
	Antiderrapante Saturno, Antislip Pigmento, Java, Pigmento, Saturno	P07	-	-	
	Cromática Alloy, Cromática Anis, Cromática Cacau, Cromática Citrus, Cromática Jade, Cromática Jet, Cromática Malva, Cromática Opala, Cromática Superbranco, Cromática Terracotta	P09	P13	P13	
	Cromática Cobalto, Cromática Coral, Cromática Ice, Cromática Palm, Cromática Pistachio, Cromática Teal	P16	P20	P20	
	Cromática Brick, Cromática Clorofila, Cromática Turquesa	-	P22	P22	
	Cromática Indigo, Cromática Lazúli	-	P32	P32	
30x60 [29,6x59,2 cm]	Geral / General / Général / General	P12	P18	P18	
	Cromática Alloy, Cromática Anis, Cromática Cacau, Cromática Citrus, Cromática Jade, Cromática Jet, Cromática Malva, Cromática Opala, Cromática Superbranco, Cromática Terracotta	-	P24	P24	
	Cromática Cobalto, Cromática Coral, Cromática Ice, Cromática Palm, Cromática Pistachio, Cromática Teal	-	P36	P36	
	Cromática Brick, Cromática Clorofila, Cromática Turquesa	-	P42	P42	
60x60 [59,2x59,2 cm]	Geral / General / Général / General	-	P36	P36	
	Cromática Alloy, Cromática Anis, Cromática Cacau, Cromática Citrus, Cromática Jade, Cromática Jet, Cromática Malva, Cromática Opala, Cromática Superbranco, Cromática Terracotta	-	P46	P46	
	Cromática Cobalto, Cromática Coral, Cromática Ice, Cromática Palm, Cromática Pistachio, Cromática Teal	-	P106	P106	
	Cromática Brick, Cromática Clorofila, Cromática Turquesa	-	P118	P118	
45x45 [44,4x44,4 cm]	Geral / General / Général / General	P12	P18	P18	
	Arizona, Ecotech	P10	-	-	
	43,5x87 [43,5x87,0 cm]	-	P127	P127	
	45x90 [44,5x89,0 cm]	-	P97	P97	
30x120 [29,6x118,4 cm]	Geral / General / Général / General	-	P97	P97	
	60x120 [59,2x118,4 cm]	Geral / General / Général / General	-	P167	P167
DEGRAU CF (DG CF) STEP (DG CF) MARCHE (DG CF) PASO (DG CF)	30x60 [29,6x59,2 cm]	Geral / General / Général / General	-	P157	P157
	15x120 [14,7x120,0 cm]	Cromática Brick, Cromática Clorofila, Cromática Turquesa	-	P197	P197
	30x120 [29,6x120,0 cm]	Cromática Indigo, Cromática Lazúli	-	P237	P237
DEGRAU CF CANTO (DG CF CANTO) CORNER STEP (DG CF CANTO) MARCHE DE COIN (DG CF CANTO) PASO DE ESQUINA (DG CF CANTO)	30x60 [29,6x59,2 cm]	Geral / General / Général / General	-	P207	P207
	15x120 [14,7x120,0 cm]	Cromática Brick, Cromática Clorofila, Cromática Turquesa	-	P247	P247
	30x120 [29,6x120,0 cm]	Cromática Indigo, Cromática Lazúli	-	P287	P287
	30x120 [29,6x120,0 cm]	Deck	-	P247	-
	Deck Smart	-	P317	-	
	Exotic, Jinko, Nordik	-	P175	-	

FORMATO (cm) SIZE (cm) FORMAT (cm) FORMATO (cm)	COLEÇÃO COLLECTION COLLECTION COLECCIÓN	peça_pieza		
		NAT MATT NAT	RECT SOFT MATT RECT	POL LAP
1,5x30 [1,5x29,6 cm]	Geral / General / Général / Standard / General	-	P20	-
1,5x60 [1,5x59,2 cm]	Geral / General / Général / Standard / General	-	P32	-

DG CF / DG CF Canto: Peças produzidas sob encomenda.
DG CF / DG CF Canto: Pieces produced on order.
DG CF / DG CF Canto: Pièces produites sur commande
DG CF / DG CF Canto: Piezas producidas por encargo

DG CF Canto: Disponível em canto esquerdo e direito.
DG CF Canto: Available in left and right corner.
DG CF Canto: Disponible en angle gauche et droit.
DG CF Canto: Canto izquierdo y derecho disponibles.

Perfil: Peças produzidas sob encomenda
Perfil: Pieces produced on order.
Perfil: Pièces produites sur commande.
Perfil: Piezas producidas por encargo.

Peças Complementares

Fittings _ Pieces Speciales _ Piezas Suplementarias

FORMATO (cm) SIZE (cm) FORMAT (cm) FORMATO (cm)	COLEÇÃO COLLECTION COLLECTION COLECCIÓN	peça_pieza		
		NAT MATT NAT	RECT SOFT MATT RECT	POL LAP
7,5x75 cm	Geral / General / Général / General	P07	-	-
9,5x30 [9,5x29,6 cm]	Geral / General / Général / General	P07	P08	P08
	Antiderrapante Saturno, Antislip Pigmento, Java, Pigmento, Saturno	P04	-	-
	Cromática Brick, Cromática Cobalto, Cromática Clorofila, Cromática Coral, Cromática Ice, Cromática Palm, Cromática Pistachio, Cromática Teal, Cromática Turquesa	P08	P10	P10
	Cromática Indigo, Cromática Lazúli	-	P14	P14
8x43,5 [8x43,5 cm]	Cromática Ice	-	P20	P20
8x45 [8x44,4 cm]	Geral / General / Général / General	P07	P08	P08
8x60 [8x59,2 cm]	Geral / General / Général / General	P10	P12	P12
	Exotic, Jinko, Nordik	-	P16	-
	Cromática Brick, Cromática Clorofila, Cromática Cobalto, Cromática Coral, Cromática Ice, Cromática Palm, Cromática Pistachio, Cromática Teal, Cromática Turquesa	-	P20	P20
8x87 [8x87,0 cm]	Cromática Ice	-	P36	P36
	8x90 [8x89,0 cm]	Geral / General / Général / General	-	P28
8x120 [8x118,4 cm]	Geral / General / Général / General	-	P28	P28
10x30	Rodapé boleado com base côncava (RBBC) Round top bullnose with cove base (RBBC) Plinthe à bord arrondi à gorge (RBBC) Rodapié redondeado con base côncava (RBBC)	P09	-	-
	Rodapé reto com base côncava (RRBC) Straight top bullnose with cove base (RRBC) Plinthe plate à gorge (RRBC) Abgekantete Sockelleiste mit Hohlsockel (RRBC) Rodapié recto con base côncava (RRBC)	-	-	-
	Ângulo externo boleado com base côncava (AEBBC) External round angle with cove base (AEBBC) Angle sortant arrondi à gorge (AEBBC) Ângulo externo redondeado con base côncava (AEBBC)	-	-	-
	Ângulo interno boleado com base côncava (AIBBC) Internal round angle with cove base (AIBBC) Angle rentrant arrondi à gorge (AIBBC) Ângulo interno redondeado con base côncava (AIBBC)	-	-	-
3x10	Ângulo externo reto com base côncava (AERBC) External straight angle with cove base (AERBC) Angle sortant plat à gorge (AERBC) Ângulo externo recto con base côncava (AERBC)	-	-	-
	Ângulo interno reto com base côncava (AIRBC) Internal straight angle with cove base (AIRBC) Angle rentrant plat à gorge (AIRBC) Ângulo interno recto con base côncava (AIRBC)	-	-	-
	Estas peças são produzidas para a coleção Cromática e Pigmento, estando sujeitas a quantidades mínimas exigidas. These pieces, produced for the Cromática and Pigmento collection, are subject to minimum required quantities. Ces pièces sont produites pour la collection Cromática et Pigmento sont soumises à une quantité minimum par commande. Estas piezas se producen para la colección Cromática y Pigmento, estando sujetas a cantidades mínimas exigidas. Coleção Cromática (Branco, Platina, Preto, Superbranco)	-	-	-
3x10	Estas peças são produzidas para a coleção Cromática e Pigmento, estando sujeitas a quantidades mínimas exigidas. These pieces, produced for the Cromática and Pigmento collection, are subject to minimum required quantities. Ces pièces sont produites pour la collection Cromática et Pigmento sont soumises à une quantité minimum par commande. Estas piezas se producen para la colección Cromática y Pigmento, estando sujetas a cantidades mínimas exigidas. Coleção Cromática (Branco, Platina, Preto, Superbranco)	P09	-	-

FORMATO (cm) SIZE (cm) FORMAT (cm) FORMATO (cm)	COLEÇÃO COLLECTION COLLECTION COLECCIÓN	peça_pieza		
		NAT MATT NAT	RECT SOFT MATT RECT	POL LAP
7x30 [7x29,6 cm]	Geral / General / Général / Standard / General	P05	P06	P06
7x45 [7x44,4 cm]	Cromática Brick, Cromática Clorofila, Cromática Ice, Cromática Turquesa	P06	P08	P08
	Cromática Indigo, Cromática Lazúli	-	P10	P10
7x60 [7x59,2 cm]	Geral / General / Général / Standard / General	P07	P08	P08
	Cromática Cobalto, Cromática Coral, Cromática Ice, Cromática Palm, Cromática Pistachio, Cromática Teal	-	P12	P12
	Cromática Brick, Cromática Clorofila, Cromática Turquesa	-	P15	P15
	Cromática Indigo, Cromática Lazúli	-	P21	P21
7x7 [7x7 cm]	Geral / General / Général / Standard / General	-	P01	P02
	Cromática Cobalto, Cromática Coral, Cromática Ice, Cromática Palm, Cromática Pistachio, Cromática Teal	-	P02	P04
	Cromática Brick, Cromática Clorofila, Cromática Indigo, Cromática Lazúli, Cromática Turquesa	-	P04	P05

TIPOLOGIAS DE PRODUTOS . TYPES OF PRODUCTS . TYPOLOGIES DE PRODUITS . TIPOLOGÍAS DE PRODUCTOS



REVESTIMENTOS CERÁMICOS VIDRADOS
GLAZED CERAMIC WALL TILES
FAÏENCE PÂTE BLANCHE
REVESTIMIENTOS CERÁMICOS VIDRIADOS



REVESTIMENTOS E PAVIMENTOS EM GRÉS PORCELÂNICO ESMALTADO
GLAZED PORCELAIN WALL/FLOOR TILES
REVÊTEMENTS MURAUX ET DE SOL EN GRÉS CÉRAME EMAILÉ
REVESTIMIENTOS Y PAVIMENTOS EN GRES PORCELÁNICO ESMALTADO



REVESTIMENTOS E PAVIMENTOS EM GRÉS PORCELÂNICO TÉCNICO
FULL BODY PORCELAIN WALL/FLOOR TILES
REVÊTEMENTS MURAUX ET DE SOL EN GRÉS CÉRAME PLEINE MASSE
REVESTIMIENTOS Y PAVIMENTOS EN GRES PORCELÁNICO TÉCNICO

ACABAMENTO DA SUPERFÍCIE . SURFACE FINISH . FINITION DE LA SUPERFICIE . ACABADO DE LA SUPERFICIE



MATE: superfície natural, não brilhante.
MATTE: natural surface, not shiny.
MAT: superfície naturelle, non brillante.
MATE: superficie natural, no brillante.



BRILHO: superfície brilhante, com alto grau de reflexão de luz.
GLOSS: shiny surface, with high degree of light reflection.
BRILLANT : superfície brillante, avec haut niveau de reflet de la lumière.
BRILLO: superficie brillante, con alto grado de reflexión de la luz.

VARIAÇÕES DE TONALIDADE . COLOUR VARIATIONS . VARIATIONS DE TONALITÉ . VARIACIONES DE TONALIDAD



VARIAÇÃO LIGEIRA: produto com ligeira variação cromática.
SLIGHT VARIATION: product with slight colour variation.
VARIATION LÉGÈRE: produit présentant une petite variation de couleur.
VARIACIÓN LIGERA: producto con ligera variación cromática.



VARIAÇÃO MÉDIA: produto com evidente variação cromática.
MEDIUM VARIATION: product with visible colour variation.
VARIATION MOYENNE: produit présentant une variation de couleur évidente.
VARIACIÓN MEDIA: producto con evidente variación cromática.



VARIAÇÃO FORTE: produto com forte variação cromática.
HIGH VARIATION: product with strong colour variation.
VARIATION FORTE: produit présentant une forte variation de couleur.
VARIACIÓN FUERTE: producto con fuerte variación cromática.



VARIAÇÃO MUITO FORTE: produto com intensa variação cromática.
VERY WIDE RANGE: product with intense colour variation.
VARIATION TRÈS FORTE : produit présentant une intense variation de couleur.
VARIACIÓN MUY FUERTE: producto con intensa variación cromática.

TIPOS DE APLICAÇÃO . TYPES OF USE . TYPES D'APPLICATION . TIPOS DE APLICACIÓN



TRÁFEGO LIGEIRO
LIGHT TRAFFIC
TRAFIC LÉGER
TRÁFICO LIGERO



TRÁFEGO MÉDIO
MEDIUM TRAFFIC
TRAFIC MOYEN
TRÁFICO MEDIO



TRÁFEGO MÉDIO-FORTE
MEDIUM HEAVY TRAFFIC
TRAFIC MOYEN-ÉLEVÉ
TRÁFICO MEDIO FUERTE



TRÁFEGO FORTE
HEAVY TRAFFIC
TRAFIC ÉLEVÉ
TRÁFICO FUERTE



TRÁFEGO MUITO FORTE
VERY HEAVY TRAFFIC
TRAFIC TRÈS ÉLEVÉ
TRÁFICO MUY FUERTE

Recomendamos a colocação de um tapete nas áreas de comunicação com o exterior, a fim de eliminar as areias e matérias abrasivas.

We recommend that a doormat be placed at the entrance of any doors leading outside, in order to remove any abrasive particles. (e.g.: sand).

Pour les revêtements muraux, nous conseillons le carrearêtes rectifiées. Toutefois, si vous appliquez le naturel (sans arêtes rectifiées), nous vous conseillons d'effectuer les joints.

Le recomendamos la colocación de una alfombra en las áreas de comunicación con el exterior, con el fin de eliminar las arenas y los materiales abrasivos.

As utilizações recomendadas são meramente indicativas; os valores podem variar em função da especificidade dos espaços onde os materiais serão aplicados. No caso de ser necessário alguma informação adicional, a Direção Técnica poderá fornecê-la, pelo que solicitamos o contacto para: revigres@revigres.pt

The recommended types of applications are indicative, as each may vary depending on the specific areas where the products are applied. For more information please contact us at: revigres@revigres.pt

Les utilisations recommandées sont indiquées uniquement à titre indicatif; les valeurs peuvent varier en fonction de la spécificité des espaces où les matériaux seront appliqués. Toutefois, pour toutes informations complémentaires, la direction technique reste à votre disposition. Contactez-nous à: revigres@revigres.pt

Los usos recomendados son meramente indicativos; los valores pueden variar en función de la especificidad de los espacios donde se aplicarán los materiales. En caso de que sea necesario alguna información adicional, la Dirección Técnica podrá facilitarla, por lo que le pedimos que se ponga en contacto con: revigres@revigres.pt

EM REVESTIMENTO IN WALL TILES EN REVÊTEMENT MURAL EN LOS REVESTIMIENTOS	TIPOS DE APLICAÇÃO . TYPES OF USE TYPES D'APPLICATION . TIPOS DE APLICACIÓN	CLASSIFICAÇÃO . CLASSIFICATION CLASSEMENT . CLASIFICACIÓN				
		1	2	3	4	5
Fachadas (revestimento de exterior) · Façades (exterior wall tiles) Façades (revêtement extérieur) · Fachadas (revestimiento de exterior)		•	•	•	•	•
	Revestimento (paredes) · Wall tiles · En revêtement mural · Revestimiento (paredes)	•	•	•	•	•
WC e Quartos Bathrooms and bedrooms WC et chambres WC y Cuartos de baño		•	•	•	•	•
	Habitaciones Homes Habitations Edifícios		•	•	•	•
	Toda a casa excepto Hall de entrada e triângulo Cozinha (bancada – fogão – frigorífico) Anywhere at home, except entrance halls and kitchen triangle (counter – cooker – refrigerator) Toute la maison, sauf le hall d'entrée et le triangle cuisine (plan de travail - cuisinière - réfrigérateur) Toda la casa excepto la entrada y el triángulo de la Cocina (encimera – cocina – frigorífico)				•	•
Vivendas Villas Pavillons Viviendas	Toda a casa · Entire home · Toute la maison · Toda la casa			•	•	•
	Toda a casa excepto zonas de contato com o exterior e triângulo cozinha Entire home, except areas in contact with the outside and kitchen triangle Toute la maison, sauf les zones de contact avec l'extérieur et le triangle cuisine Toda la casa excepto las zonas de contacto con el exterior y el triángulo de la cocina		•	•	•	•
	Toda a casa · Entire home · Toute la maison · Toda la casa			•	•	•
Escolas · Schools · Établissements scolaires · Escuelas				•	•	•
	Lojas · Centros comerciais · Shops · Shopping centers Magasins · Centres commerciaux · Tiendas · Centros comerciales			•	•	•
Hotéis · Hotels · Hôtels · Hoteles				•	•	•
	Organismos públicos · Public buildings Institutions publiques · Organismos públicos			•	•	•
Aeroportos · Airports · Aéroports · Aeropuertos				•	•	•
	Escritórios · Bancos · Offices · Banks Bureaux · Banques · Oficinas · Bancos			•	•	•
Cinemas · Teatros · Museus · Cinemas · Theatres · Museums Cinéma · Théâtres · Musées · Cines · Teatros · Museos				•	•	•
	Restaurantes · Bares · Cafés · Restaurants · Bars · Cafes Restaurants · Bars · Cafés · Restaurants · Bares · Cafés			•	•	•
Áreas Desportivas · Sports facilities · Zones sportives · Áreas Deportivas				•	•	
Espaços Públicos · Public areas · Espaces publics · Espacios Públicos				•	•	
Discotecas · Nightclubs · Discothèques · Discotecas				•	•	
Hospitais · Hospitals · Hôpitaux · Hospitales				•	•	
Supermercados · Supermarkets · Supermarchés · Supermercados				•	•	
Estações · Railway stations · Gares · Estaciones					•	
Indústria · Industry · Industrie · Industria					•	

EM PAVIMENTO · IN FLOOR TILES · EN REVÊTEMENT DE SOL · EN LOS PISOS

Ícones

Icons _ Icones _ Iconos

VALOR DE RESISTÊNCIA À DERRAPAGEM (RD) PELO MÉTODO DO PÊNDULO · SLIP RESISTANCE VALUE (RD) THROUGH THE PENDULUM METHOD
 VALEUR DE RÉSIDENCE AU DÉRAPAGE (RD) PAR LA METHODE DU PENDULE · VALOR DE RESISTENCIA AL DESLIZAMIENTO (RD) POR EL MÉTODO DEL PÊNDULO

NORMA . STANDARD . NORME . NORMA UNE-ENV 12633: 2003

0
 class RD ≤ 15
SUPERFÍCIE POLIDA, SEM CARACTERÍSTICAS ANTIDESLIZANTES
 POLISHED SURFACE, WITHOUT NON-SLIP CHARACTERISTICS
SUPERFÍCIE POLIE, SANS CARACTÉRISTIQUES ANTIDÉRAPANTES
 SUPERFICIE PULIDA, SIN CARACTERÍSTICAS ANTIDESLIZANTES

1
 class 15 < RD ≤ 35
SUPERFÍCIE NATURAL, POUCO ANTIDESLIZANTE
Produtos indicados para locais secos e sem rampas inclinadas.
 NATURAL SURFACE, SLIGHTLY NON-SLIP
 Products suited to dry areas without sloped ramps.
SUPERFÍCIE NATURELLE, LÉGÈREMENT ANTIDÉRAPANTE
Produits indiqués pour des lieux secs et sans rampes inclinées.
 SUPERFICIE NATURAL, POCO ANTIDESLIZANTE
 Productos indicados para lugares secos y sin rampas inclinadas.

2
 class 35 < RD ≤ 45
SUPERFÍCIE RUGOSA, COM CARACTERÍSTICAS ANTIDESLIZANTES
Produtos indicados para zonas interiores húmidas (exemplos: entradas de edifícios, esplanadas, escadas, vestiários, casas-de-banho / lavabos e cozinhas).
 ROUGH SURFACE, WITH NON-SLIP CHARACTERISTICS
 Products suited to damp indoor areas (e.g. building entrances, terraces, stairs, cloakrooms, bathrooms/lavatories and kitchens).
SUPERFÍCIE RUGUEUSE, AVEC CARACTÉRISTIQUES ANTIDÉRAPANTES
Produits indiqués pour les zones intérieures humides (exemples : entrées de bâtiments, esplanades, escaliers, vestiaires, salles de bain / lavabos et cuisines).
 SUPERFICIE RUGOSA, CON CARACTERÍSTICAS ANTIDESLIZANTES
 Productos indicados para zonas interiores húmedas (ejemplos: entradas de edificios, terrazas, escaleras, vestuarios, cuartos de baño / lavabos y cocinas).

3
 class RD > 45
SUPERFÍCIE MUITO RUGOSA, MUITO ANTIDESLIZANTE
Produtos indicados para as seguintes áreas: zonas interiores onde, além de água, possam haver agentes como gordura, lubrificantes, entre outros, que reduzam a resistência à derrapagem (exemplos: cozinhas industriais, indústrias, zonas de uso industrial, matadouros, parques de estacionamento) e zonas exteriores (exemplos: piscinas, entre outros).
 VERY ROUGH SURFACE, HIGHLY NON-SLIP
 Products suited to the following areas: indoor areas which, in addition to water, may have grease, lubricants and similar substances which reduce slip resistance (e.g. industrial kitchens, factories, industrial use areas, slaughterhouses, parking lots) and outside areas (e.g. swimming pools, etc.).
SUPERFÍCIE TRÈS RUGUEUSE, TRÈS ANTIDÉRAPANTE
Produits indiqués pour les zones suivantes : zones intérieures où, en plus de l'eau, il peut y avoir des agents tels que graisse, lubrifiants, entre autres, qui réduisent la résistance au dérapage (exemples : cuisines industrielles, industries, zone à usage industriel, abattoirs, parkings) et zones extérieures (exemples : piscines, entre autres).
 SUPERFICIE MUY RUGOSA, MUY ANTIDESLIZANTE
 Productos indicados para las siguientes áreas: zonas interiores donde, además de agua, pueda haber agentes tales como grasa, lubricantes, entre otros, que reduzcan la resistencia al deslizamiento (ejemplos: cocinas industriales, industrias, zonas de uso industrial, mataderos, aparcamientos) y zonas exteriores (ejemplos: piscinas, entre otros).

NORMA . STANDARD . NORME . NORMA ANSI A137 (DCOF)

APLICAÇÕES EM PAVIMENTO FLOOR APPLICATIONS APPLICATIONS AU SOL APLICACIONES EN PAVIMENTO	VALOR DCOF QUANDO MOLHADO TARGET DCOF WET VALEUR DCOF LORSQUE HUMIDE VALOR DCOFO CUANDO ESTÁ HÚMEDO	ADEQUADO SUITABLE ADAPTÉ ADECUADO
INTERIOR SECO E NIVELADO DRY & LEVEL INTERIOR INTÉRIEUR SEC ET NIVELÉ INTERIOR SECO Y NIVELADO	N/A	✓
INTERIOR MOLHADO E NIVELADO WET & LEVEL INTERIOR INTÉRIEUR HUMIDE ET NIVELÉ INTERIOR HÚMEDO Y NIVELADO	≥ 0,42	✓
APLICAÇÕES NO EXTERIOR EXTERIOR APPLICATIONS APPLICATIONS À L'EXTÉRIEUR APLICACIONES EN EL EXTERIOR	≥ 0,60	
RAMPAS E INCLINAÇÕES RAMPS & INCLINES RAMPES ET PENTES RAMPAS E INCLINACIONES	≥ 0,65	

NORMA . STANDARD . NORME . NORMA BS 7976-2: 2002

FLOORS (PTV) Pendulum Test Value 4S (*)	POTENCIAL ANTIDERRAPANTE SLIP POTENTIAL ANTIDÉRAPANTES POTENTIEL POTENCIAL ANTIDERRAPANTE
0-24	Muito High Très Muy
25-35	Moderado Moderate Modéré Moderado
36+	Pouco Low Légèrement Poco
75+	Muito Pouco Extremely Low Très peu Muy Poco

(*) "4S" - Identifica a borracha tipo #96 (normalizada que simula o calçado).
 (*) "4S" - Identifies rubber type #96 (standard simulated Shoe Sole).
 (*) "4S" - Identifie le caoutchouc type #96 (normalisé qui simule la sole des chaussures).
 (*) "4S" - Identifica el caucho tipo #96 (estándar que simula la suela del calzado).

NORMA . STANDARD . NORME . NORMA DIN 51130

RESISTÊNCIA AO ESCORREGAMENTO · ANTI SLIP RESISTANCE
 RÉSIDENCE À LA GLISSANCE · RESISTENCIA ANTIDESLIZAMIENTO



R	Angle
R9	6° ≤ angle < 10°
R10	10° ≤ angle < 19°
R11	19° ≤ angle < 27°
R12	27° ≤ angle < 35°
R13	angle ≥ 35°

NORMA . STANDARD . NORME . NORMA DIN 51097

RESISTÊNCIA AO ESCORREGAMENTO · ANTI SLIP RESISTANCE
 RÉSIDENCE À LA GLISSANCE · RESISTENCIA ANTIDESLIZAMIENTO



Class	Angle
A	12° ≤ angle < 18°
B	18° ≤ angle < 24°
C	angle ≥ 24°

NORMA . STANDARD . NORME . NORMA NF UPEC

UPEC



Classificação UPEC - Norma NF EN 14411 (Centre Scientifique et technique du Bâtiment - CSTB, França):
 Mosaicos cerâmicos - Definições, classificações, características e marcação.
 No caso de ser necessária a classificação de um produto específico, a Direção Técnica poderá fornecê-la, pelo que solicitamos o contacto para: revigres@revigres.pt

UPEC Classification – French Standard NF EN 14411 (Centre Scientifique et technique du Bâtiment - CSTB, France):
 Ceramic mosaics - Definitions, classifications, characteristics and marking.
 When a specific product needs to be classified, the Technical Management may provide it so we request contact to: revigres@revigres.pt

Classement UPEC - Norme française NF EN 14411 (Centre Scientifique et technique du Bâtiment - CSTB, France):
 Carreaux céramiques - Définitions, classification, caractéristiques et marquage.
 Si la classification d'un produit spécifique est nécessaire, la direction technique pourra la fournir. Pour cela, nous vous prions de nous contacter à: revigres@revigres.pt

Clasificación UPEC - Norma Francesa NF EN 14411 (Centre Scientifique et technique du Bâtiment - CSTB, Francia):
 Mosaicos cerâmicos - Definiciones, clasificaciones, características y marcación.
 En caso de necesitar la clasificación de un producto en concreto, puede solicitarla al Departamento Técnico en la dirección: revigres@revigres.pt

U

RESISTÊNCIA À ABRASÃO
 RESISTANCE TO ABRASION
 RÉSIDENCE A L' ABRASION
 RESISTENCIA A LA ABRASIÓN

P

RESISTÊNCIA MECÂNICA
 MECHANICAL RESISTANCE
 RÉSIDENCE MECANIQUE
 RESISTENCIA MECÁNICA

E

COMPORTAMENTO EM PRESENÇA DE ÁGUA
 BEHAVIOUR IN WATER PRESENCE
 COMPORTEMENT EN PRESENCE D'EAU
 COMPORTAMIENTO CON PRESENCIA DE AGUA

C

RESISTÊNCIA A PRODUTOS QUÍMICOS
 CHEMICAL PRODUCTS RESISTANCE
 RÉSIDENCE AUX PRODUITS CHIMIQUES
 RESISTENCIA A PRODUCTOS QUÍMICOS



Acabamento

Finish _ Finition _ Acabado

SUPERFÍCIE · SURFACE · SURFACE · SUPERFICIE



Natural
Natural
Naturelle
Natural



Lapado
Lapped
Lustré
Lapado

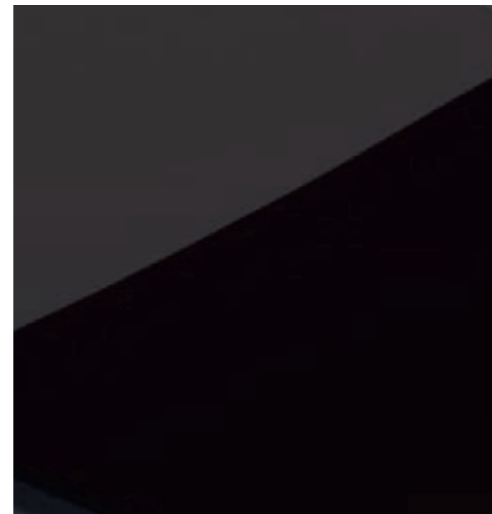

Polido
Polished
Poli
Pulido

	SIGNIFICA.	ACABAMENTO (SUPERFÍCIE)	ACABAMENTO (ARESTA)
NAT.	Natural.	Natural.	Normal.
MATT NAT.	Mate Natural.	Natural.	Normal.
RECT.	Retificado.	Natural.	Retificada.
MATT RECT.	Mate Retificado.	Natural.	Retificada.
SOFT.	Amaciado Mate.	Natural.	Retificada.
POL.	Polido.	Polida.	Retificada.
LAP.	Lapado.	Lapada.	Retificada.

	MEANS.	FINISH (SURFACE)	FINISH (EDGES)
NAT.	Natural.	Natural.	Normal.
MATT NAT.	Matt Natural.	Natural.	Normal.
RECT.	Rectified.	Natural.	Rectified.
MATT RECT.	Matt Rectified.	Natural.	Rectified.
SOFT.	Soft Matt.	Natural.	Rectified.
POL.	Polished.	Polished.	Rectified.
LAP.	Lapped.	Lapped.	Rectified.

	FINITION (SURFACE)	FINITION (ARÊTE)
NAT.	Naturel.	Naturelle.
MATT NAT.	Mat Naturel.	Naturelle.
RECT.	Rectifié.	Naturelle.
MATT RECT.	Mat Rectifié.	Naturelle.
SOFT.	Satiné Mat.	Naturelle.
POL.	Poli.	Poli.
LAP.	Lustré.	Lustré.

	ACABADO (SUPERFÍCIE)	ACABADO (ARISTA)
NAT.	Natural.	Normal.
MATT NAT.	Mate Natural.	Normal.
RECT.	Rectificado.	Rectificada.
MATT RECT.	Mate Rectificado.	Rectificada.
SOFT.	Suave Mate.	Rectificada.
POL.	Pulido.	Rectificada.
LAP.	Lapado.	Rectificada.

"MATT NAT" é a nova designação para os produtos anteriormente denominados "NAT" e corresponde ao produto com superfície natural e aresta normal. "MATT RECT" é a nova designação para os produtos anteriormente denominados "RECT" e corresponde ao produto com superfície natural e aresta retificada. Estas alterações consistem apenas na designação utilizada, pois correspondem exatamente ao mesmo produto. Esta transição será feita gradualmente, pelo que as designações "MATT NAT", "MATT RECT", "NAT" e "RECT" coexistirão simultaneamente durante algum tempo no mercado.

"MATT NAT" is the new name of the products previously called "NAT" and corresponds to the product with a natural surface and regular edges. "MATT RECT" is the new name of the products previously called "RECT" and corresponds to the product with a natural surface and rectified edges. These are only changes to the names used, since the products themselves remain exactly the same. The change will be carried out gradually, so the names "MATT NAT", "MATT RECT", "NAT" and "RECT" will be used concomitantly on the market for a while.

"MATT NAT" est la nouvelle désignation des produits dénommés auparavant "NAT" et correspond au produit avec surface naturelle et arête normale. "MATT RECT" est la nouvelle désignation des produits dénommés auparavant "RECT" et correspond au produit avec surface naturelle et arête rectifiée. Ce ne sont que des modifications de la désignation utilisée, car elles correspondent exactement au même produit. Cette transition va se mettre en œuvre progressivement, donc, les désignations "MATT NAT", "MATT RECT", "NAT" et "RECT" vont coexister en simultané sur le marché pendant un certain temps.

"MATT NAT" es la nueva denominación para los productos anteriormente denominados "NAT" y corresponde al producto con superficie natural y arista normal. "MATT RECT" es la nueva denominación para los productos anteriormente denominados "RECT" y corresponde al producto con superficie natural y arista rectificada. Estas modificaciones afectan solo a la denominación utilizada, ya que corresponden exactamente al mismo producto. Esta transición se realizará de forma gradual, por lo que las denominaciones "MATT NAT", "MATT RECT", "NAT" y "RECT" coexistirán simultáneamente durante un tiempo en el mercado.

Calibres

Calibres _ Calibres _ Calibre

As dimensões exatas - em centímetros - dos produtos com aresta retificada referidas ao longo do catálogo, são relativas ao calibre mais usual. As dimensões dos restantes calibres estão indicadas na tabela de calibres:

The exact sizes (in cm) of the products with rectified edges shown throughout the catalogue refer to the most common caliber. The sizes of other calibres are shown in the calibre table:

Les dimensions exactes des produits à arête rectifiée, en centimètres, mentionnés dans le catalogue se rapportent au gabarit le plus courant. Les dimensions des autres gabarits sont indiquées dans le tableau des gabarits:

Las dimensiones exactas, en centímetros, de los productos con arista rectificada referidas a lo largo del catálogo, se refieren al calibre más habitual. Las dimensiones de los restantes calibres están indicadas en la tabla de calibres:

TABELA DE CALIBRES · CALIBRE TABLE · TABLEAU DES CALIBRES · TABLA DE CALIBRES



NAT MATT NAT	FORMATO SIZE FORMAT NENNMASS FORMATO (cm)	CALIBRE (cm)						
		3	2	1	0 (dimensão nominal)	09	08	
		(nominal size)						
7,5					7,60	7,40		
15		15,14	15,10	15,06	15,02	14,98	14,94	14,90
20		20,21	20,15	20,09	20,03	19,97	19,91	19,85
30		30,31	30,22	30,13	30,04	29,95	29,86	29,77
40		40,42	40,30	40,18	40,06	39,94	39,82	39,70
45		45,49	45,35	45,21	45,07	44,93	44,79	44,65
60		60,63	60,45	60,27	60,09	59,91	59,73	59,55
75		75,70	75,50	75,30	75,10	74,90	74,70	74,50



RECT MATT RECT SOFT	POL LAP	FORMATO (cm) SIZE (cm) FORMAT (cm) FORMATO (cm)	CALIBRE (cm)									
			0Z	0	08	06	04	02	00			
			10				9,65	9,60	9,55	9,50		± 0,1%
15					14,90	14,70	14,50	14,30		± 0,1%		
19,5					19,50					± 0,1%		
29					29,00					± 0,1%		
30						29,80	29,60	29,40	29,20	± 0,1%		
43,5						43,50				± 0,1%		
45			44,50			44,70	44,40	44,10	43,80	± 0,1%		
60						59,60	59,20	58,80	58,40	± 0,1%		
87							87,00			± 0,1%		
90			89,00				89,40	88,80	88,20	87,60	87,00	± 0,1%
120							120,00	119,20	118,40	117,60	116,80	± 0,1%
180									180,00			± 0,1%

Os valores a bold respeitam ao calibre mais usual de cada formato.

Values listed in bold refer to the usual calibre of each format.

Les valeurs en gras sont relatifs au calibre le plus habituel de chaque format.

Los valores en negrita respetan el calibre más habitual de cada formato.

Na conjugação de produtos e/ou acabamentos (natural, retificado, polido) diferentes na mesma área (do revestimento ou do pavimento), o calibre dos produtos deve ser igual - solicitamos esta indicação ao realizar a encomenda. No formato 30x60cm, não é possível conjugar Revestimento Cerâmico () de aresta normal com outras tipologias (); neste formato, a conjugação de produtos com diferentes tipologias só é possível com a aresta retificada.

When combining different products and/or finishes (natural, rectified, polished) in the same area (of the wall or floor tiles), the calibre of the products must be the same - in this case, please inform us when placing your order. In 30x60 cm format, Ceramic Wall Tile () with normal edges cannot be combined with other types (); in this format, different types of products can only be combined with rectified edges.

Lors de l'association de produits et/ou finitions (naturelle, rectifiée, polie) différents sur une même surface (du revêtement ou du sol), le calibre des produits doit être identique. - Nous vous demanderons de fournir cette information lors de votre commande. Dans le format 30x60cm, il n'est pas possible de conjuguer Revêtement céramique () à arête normale, avec d'autres typologies (); dans ce format, la conjugaison de produits de différentes typologies n'est possible qu'avec l'arête rectifiée.

Para combinar varios productos y/o acabados (natural, rectificado, pulido) diferentes en la misma área (de revestimiento o de pavimento), deben coincidir los calibres de los productos, le solicitamos esta indicación al realizar el pedido. En el formato 30x60cm, no es posible combinar el Revestimiento Cerâmico () de arista normal con otras tipologias (); en este formato, la combinación de productos con distintas tipologias solo es posible con la arista rectificada.

Assentamento e Manutenção

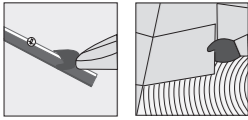

ANTES DO ASSENTAMENTO

O MATERIAL

Confirmar se existe material suficiente para realizar toda a obra e se todas as caixas pertencem à mesma Qualidade, Tonalidade e Calibre. No caso de pretender combinar produtos diferentes, deverá utilizar-se materiais com arestas retificadas e produtos com o mesmo calibre.

O SUPORTE

Verificar que o suporte não apresenta irregularidades de planimetria superiores a 5mm. Caso contrário, deverá proceder-se ao seu nivelamento.

DURANTE O ASSENTAMENTO

O MATERIAL

Aconselha-se a utilização, alternada, de mosaicos retirados de várias caixas de modo a uniformizar a variabilidade do produto colocado. A aplicação de materiais em contrafiada é tecnicamente aconselhada, desde que seja a 1/4 da peça. Caso o produto tenha um padrão irregular, a sua aplicação deve ser aleatória, isto é, o padrão deve ser aplicado em diferentes direções. Aconselha-se a utilização de sistemas de nivelamento que evitam a criação de desníveis durante a colocação dos ladrilhos, tanto em pavimentos como em revestimentos, nomeadamente, em formatos 30x30cm e superiores. Utilizando sempre dupla colagem.

AS JUNTAS

De modo a prevenir o potencial descolamento do material cerâmico, é aconselhada a aplicação do produto com juntas. Existem vários tipos de juntas:

a) Junta de colocação: espaço regular deixado entre duas peças.

Juntas mínimas recomendadas:

- Acabamento NAT, MATT NAT: 4mm
- Acabamento RECT, MATT RECT, SOFT, LAP, POL: 2mm
- Revestimentos exteriores: 5mm

O preenchimento das juntas de colocação deve ser efetuado na diagonal em relação às juntas.

b) Junta de fracionamento: subdivide o revestimento em áreas mais pequenas aliviando as tensões geradas. Recomenda-se a sua utilização em áreas com as seguintes dimensões:

Pavimentos:

- Interiores: a partir de 32 m², ou quando um dos lados é superior a 8 metros contínuos.
- Exteriores: a partir de 25 m², ou quando um dos lados é superior a 5 metros contínuos.

Revestimentos:

- Interiores: a partir de 32 m², ou quando um dos lados é superior a 8 metros.
 - Exteriores: deve efetuar-se um fracionamento na horizontal em cada 3 metros, e na vertical em cada 5 metros.
- c) Junta perimetral ou de esquina: encontra-se na mudança de planos, quer no encontro entre paredes e pavimentos, quer nas esquinas de paredes.

d) Junta estrutural: espaço regular entre duas estruturas, prevista no projeto. Em nenhuma circunstância o seu espaço deve ser preenchido com qualquer material.

Quando são utilizadas juntas com coloração forte ou escura, deve ser realizada uma experiência prévia em peças de reserva para verificar o seu comportamento. Neste caso, recomenda-se a aplicação de um primário de proteção nas peças.

Na aplicação de materiais com superfície rugosa ou estruturada, antes de rejuntar, deve aplicar-se um protetor.

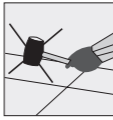

Limpeza das Juntas

As juntas de coloração forte ou escura exigem uma limpeza mais cuidada e frequente durante o assentamento.

Para prevenir ou limpar os fungos que escurecem as juntas cerâmicas, deve usar-se um betume com ação antifúngica na aplicação e, após a secagem, deve ser aplicado um agente hidrófugo (que preserva a humidade) ou qualquer outro tipo de base aquosa.

A manutenção deverá ser feita de 4 em 4 anos com a renovação da aplicação deste produto.

Deve fazer-se a limpeza das juntas quando a argamassa de juntas começar a endurecer. Não utilizar demasiada água na limpeza, uma vez que provoca a dispersão do pigmento e a descoloração precoce da junta.

Passadas 24 horas, deve fazer-se uma limpeza geral usando um pano seco ou humedecido. Para garantir maior resistência da junta à humidade, deve-se hidrofugar decorridas 2 ou 3 semanas, após a betumação.

A COLA

Para conseguir uma boa aderência, é necessário utilizar um cimento-cola adequado e fazer-se sempre colagem dupla, ou seja, espalhar a cola no suporte e no tardoz (parte de trás) da peça [\(ver quadro página 408\)](#).

Ao fazer o assentamento das peças, coloque-as ligeiramente afastadas da sua posição e arraste-as até à sua posição final fazendo um ligeiro movimento com os dedos. Para bater o material e garantir que os cordões da cola ficam bem esmagados, aconselhamos a utilização de martelos de borracha branca. **Não utilize martelos de borracha negra pois podem deixar marcas.**

No final da aplicação, faça uma limpeza geral para retirar os resíduos de cola que tenham ficado sobre as peças, evitando que endureçam e dificultem posteriormente a limpeza final.

Para o assentamento de peças de grande formato, sugerimos a utilização de niveladores para ajudar a posicionar e nivelar a junta entre peças. Estes acessórios plásticos devem ser utilizados após a aplicação da cola.

CORTE / FUROS

Os cortes / furos do material dependem da tipologia de produto.

No caso particular do porcelanato, que se caracteriza pela sua baixa absorção de água e elevada resistência mecânica, deve-se utilizar um disco / broca diamantados. [\(ver quadro página 408\)](#).

DEPOIS DO ASSENTAMENTO

PROTEÇÃO

Após o assentamento do material cerâmico e antes da conclusão da obra, recomenda-se que todo o pavimento seja devidamente protegido, de modo a evitar que a superfície fique danificada pela movimentação de pessoas e/ou materiais afetos aos trabalhos.

LIMPEZA

No final da obra, o material deve ser limpo de toda a sujidade, com produtos químicos adequados aos tipos de resíduos existentes. É importante obedecer às instruções de aplicação destes produtos e ter a absoluta certeza que os mesmos não contêm ácido fluorídrico. Recomendamos que estes produtos sejam ensaiados previamente numa peça de reserva.

É fundamental que todos os resíduos e produtos químicos utilizados sejam completamente removidos, com várias passagens de água limpa.

No caso de material polido, a camada superficial de impermeabilizante deve ser removida, de modo a restituir o brilho original do material. Para tal, recomenda-se a sua remoção com uma esponja utilizando um detergente próprio, álcool ou diluente celuloso.



MANUTENÇÃO

A manutenção e limpeza dos produtos cerâmicos é muito prática e fácil. Para a sua limpeza diária, deve-se utilizar água (de preferência tépida) e um detergente neutro. É recomendável que a utilização desse detergente seja feita em quantidades diminutas, de modo a que o mesmo possa ser completamente removido após a limpeza.

Nos acabamentos rústicos e antideslizantes, é conveniente a utilização de uma escova de fibra dura, para extrair a sujidade que se acumula na superfície rugosa.

Para uma boa conservação do produto, recomendamos a colocação de tapetes nas zonas de maior passagem / tráfego, nomeadamente nas áreas de comunicação com o exterior, de modo a evitar-se a circulação de areias, prejudiciais a qualquer tipo de pavimento.

Relativamente aos decorados, especialmente nos produtos em vidro e/ ou metalizados a ouro ou platina, não devem ser utilizados utensílios ou produtos de limpeza ácidos e/ou abrasivos, os quais poderão danificar a decoração.

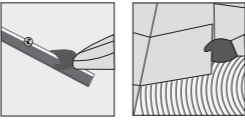

BEFORE LAYING THE MATERIAL

THE MATERIAL

Check to see that enough material has been delivered to complete the work and if all boxes are the same Quality, Shade and Calibre. If you wish to combine different products, use material with rectified edges and products of the same calibre.

THE SUBSTRATTE

Make sure the substrate shows no signs of unevenness greater than 5mm. Otherwise it must be levelled.

DURING THE LAYING

THE MATERIAL

It is best to alternate tiles taken from various boxes to ensure uniform variability of laid product. Laying rows of tiles interrupting the joints is technically advisable, as long they overlap 1/4 of the adjoining piece. If the product has an irregular pattern, lay at random, i.e. the pattern must be laid in different directions. The use of levelling systems that avoid unevenness in the tiles applied to both floors and walls, especially for 30x30cm size tiles and larger, is advised. Always apply adhesive to both surfaces.

THE JOINTS

To prevent ceramic tiles from detaching, it is advisable to leave a space for grout between the tiles. There are several types of grout spacing:

a) Placing joint: Regular space between two tiles.

Minimum recommended space:

- NAT, MATT NAT finish: 4mm
- RECT, MATT RECT, SOFT, LAP, POL finish: 2mm
- Exterior linings: 5mm

Grouting should be applied diagonally in relation to the joints.

b) Fraction joints: Subdivide panelling into smaller areas to release tension. Recommended in areas with the following dimensions:

Floors:

- Indoor: over 32 m², or when one of the sides is more than 8 meters long.
- Outdoor: over 25 m², or when one of the sides is more than 5 meters long.

Walls:

- Indoor: over 32 m², or when one of the sides is more than 8 meters long.
- Outdoor: a horizontal expansion joint should be inserted every 3 meters, and a vertical one every 5 meters.

c) Perimeter or corner joint: Helps to finish off a plane, for use where wall and floor join, or at wall corners.

d) Structural joint: Regular space between two structures, as per design. Under no circumstances must these joints be filled with any sort of material.

Where bright or dark colour grout is used, experiment first on some extra tiles. In this case, a primary coating should be applied for protection of the ceramic pieces. Apply protection on textured or structured tiles before joining.

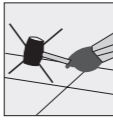

Joint cleaning

Joints with bright or dark colour grout require a considerable amount of cleaning during laying of the tiles.

To prevent or clean fungi that cause the tile joints to darken, apply anti-fungal cement and let it dry completely. Then apply a hydrophobic agent (to keep humidity out) or any other water-based seal.

Maintenance requires the reapplication of this seal every 4 years.

Clean the joints when the mortar in the joints begins to set. Avoid using excess water, as too much water will cause pigment dispersion and discolouration of the joints.

After 24 hours, clean the surface with a dry or damp cloth. To ensure high humidity resistance, 2 to 3 weeks after grouting apply waterproof seal.

THE ADHESIVE

To ensure adequate bonding, use a cement-based adhesive and apply to both surfaces, i.e. on the subsurface and reverse side of tile [\(see table on page 408\)](#).

When laying the tiles, place them slightly to one side and gently slide them into place with your fingers. To tap the tiles and ensure that the adhesive cords have been crushed properly, use a white rubber mallet. Do not use black rubber mallets, which may leave marks.

After all of the tiles have been laid, remove all excess adhesive from the tiles before it sets and makes final clean up more difficult.

When laying large format tiles, use levelling spacers to ensure proper installing and levelling of tiles. Use the plastic spacers after the adhesive has been applied.

CUTTING/HOLES

Cutting/making holes depends on the type of tiles.

In the particular case of porcelain tiles, which have low water-resistance and high mechanical strength, use a diamond disc / drill bit. [\(see table on page 408\)](#)

AFTER THE LAYING

PROTECTION

After the porcelain tiles have been laid and before the whole project is complete, we recommend protecting the entire surface from damage caused by the movement of people and/or materials belonging to the works.

CLEANING

At the end of the project, clean tiles with the appropriate chemicals for removing existing residues. Follow the use instructions of the cleaning products and make sure they do not contain hydrofluoric acid. We recommend you test the products previously on an extra tile.

It is crucial that you rinse the tiles several times to remove all residues and chemical products.

The waterproof seal used on the surface of polished tiles should be removed to restore the original shine of the tiles. Use a sponge and suitable detergent, alcohol or cellulose thinner.



MAINTENANCE

Maintaining and cleaning ceramic tiles is very practical and easy. For daily cleaning, use water (preferably warm) and a neutral detergent. We recommend you use only very small amounts of detergent, which can be removed completely after cleaning.

Use a hard brush on tiles with rustic and anti-slip finish to remove all grit in between the cracks.

We recommend you place mats in busy areas to preserve tiles from wear, especially in areas with traffic from the exterior, to prevent bringing in sand, which is damaging to any type of floor.

On decorative tile, especially on glass and/or gold or platinum metallic surfaces, do not use tools or acid and/or abrasive cleaning products, which may damage the decorative surface.

Pose et Entretien

Avant la pose et le matériel



Diagramme illustrant la pose d'une dalle sur un support et la coupe d'une dalle pour un joint.

AVANT LA POSE
LE MATÉRIAU

Se certifier que le matériau est suffisant pour la réalisation de tout l'ouvrage et que toutes les boîtes ont la même Qualité, Tonalité et Calibre.
Si vous souhaitez combiner différents produits, vous devrez utiliser des matériaux avec des bords rectifiés et des produits de même calibre.

Diagramme illustrant la pose d'une dalle sur un support et la coupe d'une dalle pour un joint.

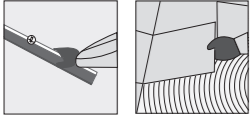
LE SUPPORT
DURANT LA POSE

LE CARRELAGE
LES JOINTS

On recommande l'utilisation, alternée, de carreaux provenant de boîtes différentes de manière à uniformiser la variabilité du produit posé.

La pose des matériaux à joints continus est techniquement conseillée, à condition qu'elle soit à 1/4 de la pièce.

Si le produit a un motif irrégulier, sa pose doit être aléatoire, c'est-à-dire que le motif doit être appliqué dans différentes directions.

Il est conseillé d'utiliser des systèmes de nivellement qui empêchent la formation d'irrégularités lors de la pose du carrelage, aussi bien au sol que sur les murs, notamment, dans les formats 30x30 cm et supérieurs. Utiliser toujours le double encollage.

Diagramme illustrant la pose d'une dalle sur un support et la coupe d'une dalle pour un joint.

LES JOINTS
LES JOINTS

Afin de prévenir le décollement potentiel du matériau céramique, il est conseillé d'appliquer le produit avec des joints. Il existe plusieurs types de joints:

a) Joint de pose : espace régulier laissé entre deux pièces.
b) Joint de fractionnement : subdivise le revêtement en surfaces plus petites, atténuant les tensions générées. Il est recommandé de l'utiliser dans les surfaces avec les dimensions suivantes:
c) Joint périphérique ou de coin : se trouve dans le changement des plans, tant dans la jonction entre les murs et les sols, que dans les angles des murs.
d) Joint structurel : espace régulier entre deux structures, prévu dans le projet. Son espace ne doit, en aucun cas, être rempli d'un quelconque matériau.

Joint de pose : espace régulier laissé entre deux pièces.

Joint de fractionnement : subdivise le revêtement en surfaces plus petites, atténuant les tensions générées. Il est recommandé de l'utiliser dans les surfaces avec les dimensions suivantes:

Sols :

- Intérieur : à partir de 32 m², ou lorsque l'un des côtés est supérieur à 8 mètres continus.
- Extérieur : à partir de 25 m², ou lorsque l'un des côtés est supérieur à 5 mètres continus.

Murs :

- Intérieurs : à partir de 32 m², ou lorsque l'un des côtés est supérieur à 8 mètres.
- Extérieurs: un fractionnement à l'horizontale doit être effectué tous les 3 mètres et à la verticale tous les 5 mètres.

Joint périphérique ou de coin : se trouve dans le changement des plans, tant dans la jonction entre les murs et les sols, que dans les angles des murs.

Joint structurel : espace régulier entre deux structures, prévu dans le projet. Son espace ne doit, en aucun cas, être rempli d'un quelconque matériau.

En cas d'utilisation de joints très colorés ou foncés, faire un test au préalable avec des pièces de réserve afin d'en vérifier le comportement. Dans ce cas, il est recommandé d'appliquer un primaire de protection sur les pièces.

Lors de l'application de matériaux à surface rugueuse ou structurée, un protecteur doit être appliqué avant le jointolement.

Nettoyage des joints



Diagramme illustrant la pose d'une dalle sur un support et la coupe d'une dalle pour un joint.

Nettoyage des joints
ENTRETIEN
LES JOINTS

L'entretien doit être effectué tous les 4 ans en procédant au renouvellement de l'application de ce produit. Les joints doivent être nettoyés lorsque le mortier commence à durcir. Ne pas utiliser trop d'eau lors du nettoyage car cela provoque une dispersion des pigments et une décoloration précoce du joint.

Après 24 heures, un nettoyage général doit être effectué avec un chiffon sec ou humide. Pour assurer une plus grande résistance du joint à l'humidité, il faut l'hydrofuger dans les 2 ou 3 semaines après le jointolement.

Nettoyage des joints

Pour obtenir une bonne adhérence, il faut utiliser une colle-ciment appropriée et procéder toujours à un double encollage, c'est-à-dire, étaler la colle sur le support et le dos du carreau (*voir le tableau à la page 408*).
Lors de la pose des pièces, placez-les légèrement éloignées de leur position et faites-les glisser jusqu'à leur position finale en faisant un léger mouvement avec les doigts. Pour tapoter le matériau et s'assurer que les cordons de colle sont bien écrasés, nous recommandons l'utilisation d'un maillet en caoutchouc blanc.

Diagramme illustrant la pose d'une dalle sur un support et la coupe d'une dalle pour un joint.

N'utilisez pas de maillets en caoutchouc noir car ils pourraient laisser des traces.

À la fin de la pose, effectuer un nettoyage général pour éliminer toute trace de colle résiduelle sur les pièces, en évitant qu'elle durcisse et rende, ultérieurement, difficile le nettoyage final.

Pour la pose de pièces de grand format, nous suggérons l'utilisation de croisillons autonivelants pour aider à positionner et à niveler le joint entre les pièces. Ces accessoires en plastique doivent être utilisés après l'application de la colle.

Diagramme illustrant la pose d'une dalle sur un support et la coupe d'une dalle pour un joint.

COUPES/ TROUS
APRÈS LA POSE
PROTECTION

Les coupes / trous du matériau dépendent de la typologie du produit. Dans le cas particulier des carreaux porcelanato, qui se caractérisent par leur faible absorption d'eau et leur résistance mécanique élevée, un disque / foret diamant doit être utilisé. (*voir le tableau à la page 408*)

Après la pose du matériau céramique et avant la fin de l'ouvrage, il est recommandé de protéger correctement tout le revêtement sol, afin d'éviter que la surface ne soit endommagée par la circulation de personnes et / ou de matériaux utilisés sur le chantier.

À la fin des travaux, le matériau doit être nettoyé en vue d'éliminer tout type de saleté, avec des produits chimiques adaptés aux types de résidus existants. Il est important de respecter les consignes d'emploi de ces produits et d'être absolument certain qu'ils ne contiennent pas d'acide fluorhydrique. Nous recommandons que ces produits soient préalablement testés sur une pièce de réserve.

Il est fondamental que tous les résidus et produits chimiques utilisés soient complètement éliminés à l'aide de plusieurs rinçages à l'eau propre. Dans le cas d'un matériau poli, la couche superficielle d'imperméabilisation doit être enlevée afin de lui restituer sa brillance d'origine. Pour ce faire, il est recommandé de l'enlever avec une éponge en utilisant un détergent approprié, alcool ou diluant cellulosique.

Entretien



Diagramme illustrant la pose d'une dalle sur un support et la coupe d'une dalle pour un joint.

ENTRETIEN
LES JOINTS
LES JOINTS

Dans les finitions rustiques et antidérapantes, il convient d'utiliser une brosse en fibre dure, pour enlever la saleté qui s'accumule sur la surface rugueuse. Pour une bonne conservation du produit, nous recommandons la mise en place de tapis dans les zones à fort trafic/ circulation, notamment dans les espaces de communication avec l'extérieur, afin d'éviter la circulation de sable, nuisible à tout type de sol.

Diagramme illustrant la pose d'une dalle sur un support et la coupe d'une dalle pour un joint.

Pour le carrelage décor, en particulier les produits en verre et / ou métallisés or ou platine, des ustensiles ou des produits de nettoyage acides et/ ou abrasifs ne doivent pas être utilisés car ils peuvent endommager la décoration.

Avant la pose et le matériel



Diagramme illustrant la pose d'une dalle sur un support et la coupe d'une dalle pour un joint.

AVANT LA POSE
LE MATÉRIEL

Confirmer la existencia de material suficiente para llevar a cabo toda la obra y si todas las cajas pertenecen a la misma calidad, tonalidad y calibre.
En caso de querer combinar productos diferentes, emplear materiales con las aristas rectificadas y productos con el mismo calibre.

Diagramme illustrant la pose d'une dalle sur un support et la coupe d'une dalle pour un joint.

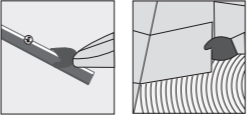
LA SUPERFICIE DE APLICACIÓN
DURANTE LA COLOCACIÓN

EL MATERIAL
LES JOINTS

Se aconseja alternar mosaicos pertenecientes a varias cajas con el fin de uniformar la variabilidad del producto colocado.
Técnicamente, se aconseja aplicar los materiales a matajunta, siempre a 1/4 de la pieza.

Si el producto tiene un patrón irregular, debe aplicarse de forma aleatoria, es decir, el patrón debe aplicarse en diferentes direcciones.
Se aconseja la utilización de sistemas de nivelación que evitan la creación de desniveles durante la colocación de las baldosas, tanto en pavimentos como en revestimientos, en particular en formatos 30x30 cm y superiores. Utilizar siempre la técnica del doble encolado.

Las juntas de colocación en diagonal con respecto a las juntas.

Con el fin de evitar el posible desencolado del material cerámico, se recomienda la aplicación del producto con juntas. Existen varios tipos de juntas:

a) Junta de colocación: espacio regular que se deja entre dos piezas.

Diagramme illustrant la pose d'une dalle sur un support et la coupe d'une dalle pour un joint.

Juntas mínimas recomendadas:

- Acabado NAT, MATT NAT: 4mm
- Acabado RECT, MATT RECT, SOFT, LAP, POL: 2mm
- Revestimientos exteriores: 5mm

Rellenar las juntas de colocación en diagonal con respecto a las juntas.

b) Junta de fraccionamiento: subdivide el revestimiento en superficies más pequeñas aliviando las tensiones generadas. Se recomienda su uso en superficies con las siguientes dimensiones:

Pavimentos:

- Interiores: a partir de 32 m² o cuando uno de los dos lados es superior a 8 metros continuos.
- Exteriores: realizar una división horizontal cada 3 metros y vertical cada 5 metros.

Revestimientos:

- Interiores: a partir de 32 m² o cuando uno de los lados es superior a 8 metros.
- Exteriores: realizar una división horizontal cada 3 metros y vertical cada 5 metros.

c) Junta perimetral o de esquina: se encuentra en el cambio de planos, tanto en el encuentro entre paredes y pavimentos, como en las esquinas de paredes.

d) Junta estructural: espacio regular entre dos estructuras, previsto en el proyecto. Su espacio no debe rellenarse con ningún material bajo ninguna circunstancia.

Quando se empleen juntas de color fuerte u oscuro, realizar una prueba previa en piezas sobrantes para comprobar su comportamiento. En tal caso, se recomienda aplicar una imprimación de protección a las piezas. Al aplicar materiales con superficie rugosa o estructurada, aplicar un protector antes de rejuntar.

Asentamiento y Mantenimiento

Antes de la colocación



Diagramme illustrant la pose d'une dalle sur un support et la coupe d'une dalle pour un joint.

AVANT LA POSE
LE MATÉRIEL

Confirmer la existencia de material suficiente para llevar a cabo toda la obra y si todas las cajas pertenecen a la misma calidad, tonalidad y calibre.
En caso de querer combinar productos diferentes, emplear materiales con las aristas rectificadas y productos con el mismo calibre.

Diagramme illustrant la pose d'une dalle sur un support et la coupe d'une dalle pour un joint.

LA SUPERFICIE DE APLICACIÓN
DURANTE LA COLOCACIÓN

EL MATERIAL
LES JOINTS

Se aconseja alternar mosaicos pertenecientes a varias cajas con el fin de uniformar la variabilidad del producto colocado.
Técnicamente, se aconseja aplicar los materiales a matajunta, siempre a 1/4 de la pieza.

Si el producto tiene un patrón irregular, debe aplicarse de forma aleatoria, es decir, el patrón debe aplicarse en diferentes direcciones.
Se aconseja la utilización de sistemas de nivelación que evitan la creación de desniveles durante la colocación de las baldosas, tanto en pavimentos como en revestimientos, en particular en formatos 30x30 cm y superiores. Utilizar siempre la técnica del doble encolado.

Las juntas de colocación en diagonal con respecto a las juntas.

Con el fin de evitar el posible desencolado del material cerámico, se recomienda la aplicación del producto con juntas. Existen varios tipos de juntas:

Diagramme illustrant la pose d'une dalle sur un support et la coupe d'une dalle pour un joint.

a) Junta de colocación: espacio regular que se deja entre dos piezas.

Diagramme illustrant la pose d'une dalle sur un support et la coupe d'une dalle pour un joint.

Juntas mínimas recomendadas:

- Acabado NAT, MATT NAT: 4mm
- Acabado RECT, MATT RECT, SOFT, LAP, POL: 2mm
- Revestimientos exteriores: 5mm

Rellenar las juntas de colocación en diagonal con respecto a las juntas.

b) Junta de fraccionamiento: subdivide el revestimiento en superficies más pequeñas aliviando las tensiones generadas. Se recomienda su uso en superficies con las siguientes dimensiones:

Pavimentos:

- Interiores: a partir de 32 m² o cuando uno de los dos lados es superior a 8 metros continuos.
- Exteriores: realizar una división horizontal cada 3 metros y vertical cada 5 metros.

Revestimientos:

- Interiores: a partir de 32 m² o cuando uno de los lados es superior a 8 metros.
- Exteriores: realizar una división horizontal cada 3 metros y vertical cada 5 metros.

c) Junta perimetral o de esquina: se encuentra en el cambio de planos, tanto en el encuentro entre paredes y pavimentos, como en las esquinas de paredes.

d) Junta estructural: espacio regular entre dos estructuras, previsto en el proyecto. Su espacio no debe rellenarse con ningún material bajo ninguna circunstancia.
Quando se empleen juntas de color fuerte u oscuro, realizar una prueba previa en piezas sobrantes para comprobar su comportamiento. En tal caso, se recomienda aplicar una imprimación de protección a las piezas. Al aplicar materiales con superficie rugosa o estructurada, aplicar un protector antes de rejuntar.

Mantenimiento



Diagramme illustrant la pose d'une dalle sur un support et la coupe d'une dalle pour un joint.

MANTENIMIENTO
LES JOINTS
LES JOINTS

El mantenimiento y la limpieza de los productos cerámicos son muy prácticos y fáciles. Para la limpieza diaria, emplear agua (preferiblemente templada) y detergente neutro. Se recomienda utilizar cantidades muy pequeñas de detergente, para poder eliminarlo por completo tras la limpieza.

En los acabados rústicos y antideslizantes, es conveniente utilizar un cepillo de fibra dura para eliminar la suciedad que se acumula en la superficie rugosa. Para una buena conservación del producto, recomendamos la colocación de alfombras en las zonas de mayor paso/tráfico, en particular en las zonas de comunicación con el exterior, para evitar la circulación de arenas, perjudiciales para cualquier tipo de pavimento.

Con respecto a las decoraciones, especialmente en los productos de vidrio o metalizados en oro o platino, no se deben utilizar utensilios ni productos ácidos o abrasivos, ya que podrían dañar la decoración.

Assentamento e Manutenção

Tile Laying and Maintenance _ Pose et Entretien _ Asentamiento y Mantenimiento

UTILIZE UM CIMENTO-COLA ADEQUADO:
USE A CEMENT-BASED ADHESIVE:
UTILISEZ UNE COLLE-CIMENT APPROPRIÉE:
UTILICE UN CEMENTO COLA ADECUADO:vv

Produto Product Produkt Productos	Formato (cm) Size (cm) Format (cm) Formato (cm)	Revestimento Interior Indoor Walls Revêtement de Mur Intérieur Revestimiento Interior						
 		Reboco e Betão Plaster and concrete Plâtre et béton Enlucido y hormigón	Cerâmica ou Pedra Ceramics or stone Céramique ou pierre Cerámica o piedra	Gesso ou Gesso Cartonado Plaster or plasterboard Plâtre ou plaque de plâtre Yeso o yeso laminado	Impermeabilizações Waterproofing Étanchéité Impermeabilización	Piças Compositas de Cimento Composite cement boards Panneaux de ciment composite Placas de cemento composite	Madeira Wood Bois Madera	Metal Metal Métal Metal
	20x20	webercol ferma	webercol ferma multi	webercol flex M	webercol flex M	webercol flex M	webercol flex M	webercol flex XXL
	20x40							
	30x45							
	30x60							
30x90	webercol flex S		webercol ferma multi	webercol flex M	webercol flex M	webercol flex M	webercol flex M	

Produto Product Produkt Productos	Formato (cm) Size (cm) Format (cm) Formato (cm)	Pavimento Interior Indoor Floors Revêtement de Sol Intérieur Pavimento Interior						Pavimento Exterior Outdoor Floors Revêtement de Sol Extérieur Pavimento Exterior					
 		Betonilha ou Betão Screed or concrete Chape ou béton Mortero u hormigón	Cerâmica ou Pedra Ceramics or stone Céramique ou pierre Cerámica o piedra	Impermeabilizações Waterproofing Étanchéité Impermeabilización	Pavimentos Aquecidos Heating Floors Sols Chauffants Suelos Recalentados	Sistemas acústicos Acoustic systems Systèmes acoustiques Sistemas acústicos	Piças Compositas de Cimento Composite cement boards Panneaux de ciment composite Placas de cemento composite	Madeira Wood Bois Madera	Metal Metal Métal Metal	Betonilha ou Betão Screed or concrete Chape ou béton Mortero u hormigón	Cerâmica ou Pedra Ceramics or stone Céramique ou pierre Cerámica o piedra	Impermeabilizações Waterproofing Étanchéité Impermeabilización	
	30x30	webercol ferma	webercol ferma multi	webercol flex M	webercol flex M	webercol flex M	webercol flex M	webercol flex M	webercol flex XXL	webercol flex S	webercol ferma multi		
	30x60									webercol flex M		webercol flex M	
	45x45	webercol flex S	webercol ferma multi	webercol flex M	webercol flex M	webercol flex M	webercol flex M	webercol flex M	webercol flex M	webercol flex XXL	webercol flex L	webercol flex XL	webercol flex L
	60x60										webercol flex L	webercol flex XL	webercol flex L
	60x120	webercol ferma multi	webercol flex XL	webercol flex XL	webercol flex XL	webercol flex XL	webercol flex XL	webercol flex XL	webercol flex XL	webercol flex XXL	webercol flex XL	webercol flex XL	webercol flex XL
	90x90												
60x180	webercol flex XL	webercol flex XXL	webercol flex XL	webercol flex XL	webercol flex XL	webercol flex XL	webercol flex XL	webercol flex XL	webercol flex XL	webercol flex XL	webercol flex XL	webercol flex XL	

CORTE / FUROS DO GRÉS PORCELÂNICO:
FULL BODY PORCELAIN CUTTING/ HOLES:
COUPES / TROUS DE GRÉS CÉRAME:
CORTE /PERFORACIONES DEL DE GRES PORCELÁNICO:

 	Cortador Manual Manual Cutter Coupeuse Manuelle Cortador Manual	
	TS-43, 57, 66 e 75 MAX	
	TR- 600 e 710 MAGNET	
	TX- 700, 900 e 1200- N	
	TZ - 850, 1020, 1300 e 1550	
 	Cortador eléctrico (Húmido) - RUBI Electric Cutter (Wet) - RUBI Coupeuse Electrique (Humide) - RUBI Cortador eléctrico (Húmido)- RUBI	Disco Wheel Disque Disco
	DV-200-1000	
	DC-250-850 e 1200	CPC / CPX / TVH
	DS-250 N 1000, 1300 e 1500 LASER & LEVEL	
	DX-250 PLUS 1000 e 1400 LASER & LEVEL	
	DX-350 N 1000 e 1300 LASER & LEVEL	

 	Cortador eléctrico (Seco) Electric Cutter (Dry) Coupeuse Electrique (Sèche) Cortador eléctrico (Seco)	Disco Wheel Disque Disco
	TC-180	
	KIT TC-180	TVA / VIPER / GPR / CPU
 	Broca Diamante - Corte Húmido - RUBI Diamond Drill - Wet Cutting - RUBI Diamond Drill - Coupe Humide - RUBI Broca Diamante - Corte Húmido - RUBI	Medidas Sizes Dimensions Dimensiones
	BROCAS EASY GRÉS	De Ø6 até Ø120
	BROCAS FURAGRES	De Ø6 até Ø120
 	Broca Diamante - Corte Seco - RUBI Diamond Drill - Dry Cutting - RUBI Diamond Drill - Coupe Sèche - RUBI Broca Diamante - Corte Seco - RUBI	Medidas Sizes Dimensions Dimensiones
	BROCAS DIAMANTE DRYGRES	De Ø6 até Ø75
 	Brocas DRYGRES 4DRILL (Seco) Drill Bits DRYGRES 4DRILL (Dry) Trépane DRYGRES 4DRILL (Sèche) Broca DRYGRES 4DRILL (Seco)	
	De Ø6 até Ø20	
	Para trabalhar com berbequim	
	Min. 1500 rpm	

Os produtos das empresas referidas são meramente exemplificativos. Além destas, existem diversas empresas que dispõem de produtos similares e de qualidade.
The products of the referred companies are merely indicated as an example. There is a number of other companies that supply quality products for this purpose.
Les produits des sociétés citées ne sont donnés qu'à titre d'exemple. D'autres sociétés commercialisent également des produits de qualité.
Los productos de las empresas indicadas son meramente ejemplificativos. Además de estas, existen diversas empresas que disponen de productos similares y de calidad.

revicomfort

ITE - Isolamento térmico pelo exterior Webertherm keramic plus
ETI - Exterior thermal insulation Webertherm keramic plus



01

FERRAMENTAS
Cortador de cerâmica manual, x-ato, fita métrica, nível e ventosa

TOOLS
Manual ceramic cutter, x-act, level ruler, tape measure and suction cup

OUTILS
Couper de céramique manuel; cutter; mètre à ruban et ventouse

INSTRUMENTOS
Cortador de cerâmica manual; cutter; cinta métrica; regla de nivelar y ventosa

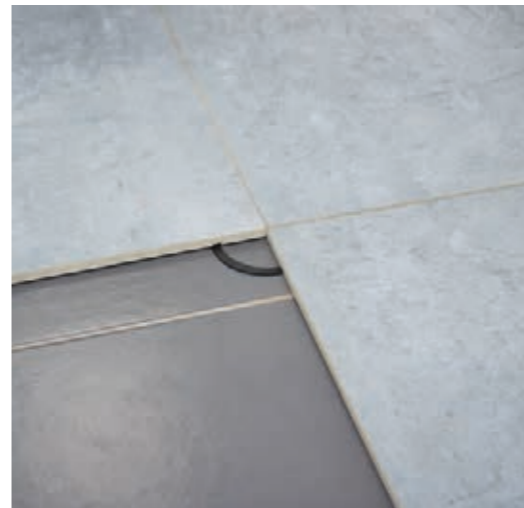

04

JUNTA
O polímero que reveste a lateral das peças deve ser encostado, formando uma junta de cerca de 1,6 mm. Dispensa cruzetas

JOINT
The polymer lining the side of the pieces must be supported, forming a joint of around 1.6 mm. Cross pieces are not required

JOINT
Le polymère qui recouvre la partie latérale des pièces doit être en appui et formé un joint d'environ 1,6 mm. Dispense d'utiliser des croisillons

JUNTA
El polímero que reviste el lateral de las piezas debe ser acoplado, formando una junta de cerca de 1,6 mm. No precisa cruzetas



02

SUPORTE
Deve estar limpo e nivelado

SUPPORT
Must be clean and levelled

SUPPORT
Doit être propre et nivelé

SOPORTE
Debe estar limpio y nivelado



05



07

CORTE
Usar máquina de corte de cerâmica manual e um x-ato para cortar o polímero

CUTTING
Use a manual ceramic cutter and x-acto to cut polymer

DÉCOUPE
Utiliser un coupeur de céramique manuel et un cutter pour couper le polymère

CORTE
Utilizar un cortador manual de cerâmica y un cutter para cortar el polímero en el dorso

Instalação

Installation _ Installation _ Instalación



03

ASSENTAMENTO
Utilizar a argola de fixação nos cantos das peças para criar um piso mais estável e compacto

LAYING
Use the securing ring in the corners of the parts so as to create a more stable, solid floor

LA POSE
Utiliser l'anneau de fixation dans les coins des pièces afin de créer un plancher plus stable et solide.

ASENTAMIENTO
Utilizar la argolla de fijación en los cantos de las piezas para crear un piso más estable y sólido



06



08

Assentamento

Laying _ Pose _ Asentamiento

revisilent

revisense

Instalação

Installation _ Installation _ Instalación



01

FERRAMENTAS

Cortador de cerâmica manual; x-ato; cimento cola; betume; fita métrica; espátulas; nível

TOOLS

Manual ceramic cutter; X-act; Flexible cement glue; Bitumen; tape measure; Spatula, level ruler

OUTILS

Couper de céramique manuel; cutter; ciment colle; mastic; spatule; mètre à ruban

INSTRUMENTOS

Cortador de cerâmica manual; Cutter ; Cimento cola; Betún; Cinta métrica; Espátula; Regla de nivelar

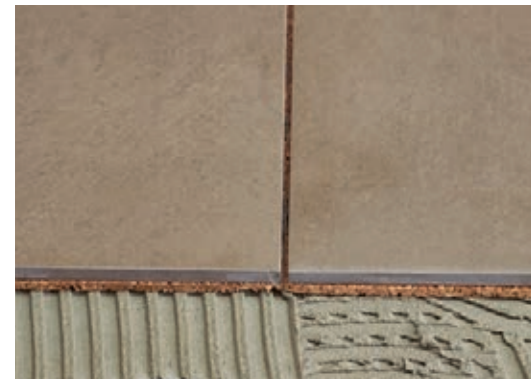

04

JUNTA

A cortiça excede, em 2 mm, o tamanho da cerâmica nas quatro arestas de cada mosaico. Dispensa cruzetas

JOINT

The cork exceeds by 2 mm the size of the all four edges of each tile. Does not need crosspieces.

JOINT

Le liège dépasse de 2 mm la dimension de la tuile sur les quatre bords de la céramique de chaque mosaïque. N'a pas besoin de croisillons.

JUNTA

El corcho excede 2 mm el tamaño de la cerámica en todos los cuatro bordes de cada cerámica. No requiere cruzetas

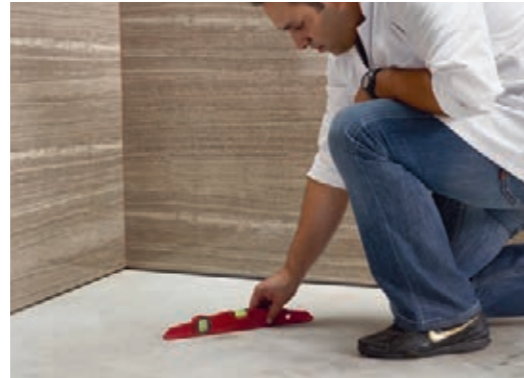

02

SUPORTE

Deve estar limpo, nivelado e com baixo nível de humidade residual

SUPPORT

Must be clean, levelled and have a low residual humidity level

SUPPORT

Doit être propre, nivelé et avec un faible niveau d'humidité résiduelle

SOPORTE

Debe estar limpio, nivelado y con bajo nivel de humedad residual



05

CORTE

Usar máquina de corte de cerâmica manual e um x-ato para cortar a cortiça no tardo

CUTTING

Use a manual ceramic cutter and a x-act to cut cork on the back

DÉCOUPE

Utiliser un coupeur de céramique manuel et un cutter pour couper le liège

CORTE

Utilizar un cortador manual de cerámica y un cutter para cortar el corcho en el dorso



03

ASSENTAMENTO

Aplicar com cimento cola
Aplicar um betume adequado – junta elástica

LAYING

Laying is carried out with cement glue
Application of appropriate bitumen

LA POSE

La pose est réalisée avec du ciment colle
Application d'un mastic approprié

ASENTAMIENTO

Aplicar con cemento cola
Aplicación de un betún adecuado



06

CORTE

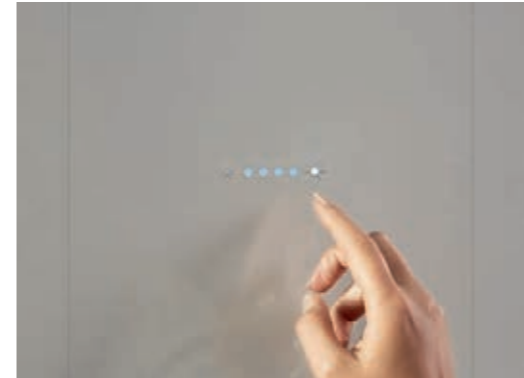

COMPOSIÇÃO

O sistema REVISENSE é composto por um revestimento cerâmico que inclui um sensor (*dimmer*, campainha ou ON/OFF).

COMPOSITION

The REVISENSE system consists of a ceramic coating with a sensor (dimmer, bell or ON/OFF).

COMPOSITION

Le système REVISENSE est composé d'un revêtement céramique qui intègre un capteur (variateur, cloche ou ON/OFF).

COMPOSICIÓN

El sistema REVISENSE se compone de un revestimiento de cerámico con un sensor (regulador de intensidad, campana o ON/OFF).

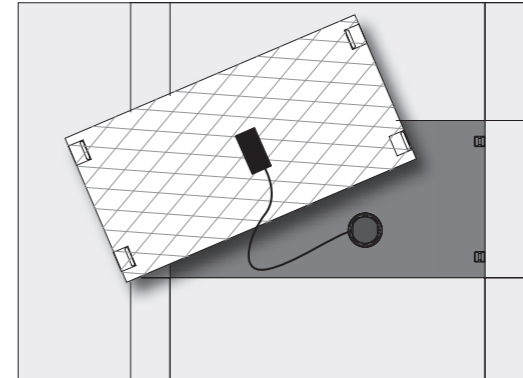

FUNCIONAMENTO

REVISENSE funciona através de um sensor compacto não visível, fixo no tardo (reverso da cerâmica), que está ligado a uma caixa controladora electrónica alojada na caixa de aparelhagem comum já existente no edifício. Não é necessário fazer uma furação na parede para aplicar este sistema.

A caixa controladora electrónica pode ser conectada a uma simples alimentação eléctrica ou a um sistema de doméstica.

OPERATION

REVISENSE operates by means of an invisible compact sensor attached to the masonry (rear of the ceramic), which is connected to an electronic controller box located in the standard electrical box already in the building. There is no need to drill holes into the wall to implement this system.

The electronic controller box may be connected to a simple electrical power source or to an automated system.

FONCTIONNEMENT

REVISENSE fonctionne grâce à un capteur compact invisible, fixé au niveau de la face de scellement (au dos de la céramique), qui est relié à un boîtier de contrôle électronique logé dans le boîtier de l'équipement commun déjà existant dans la construction. Il n'est pas nécessaire de faire un trou dans le mur pour installer ce système.

Le boîtier de contrôle électronique peut être relié à une simple alimentation électrique ou à un système de domotique.

FUNCIONAMIENTO

REVISENSE funciona mediante un sensor compacto oculto, fijado a la parte posterior (reverso de la cerámica) y conectado a una caja de control electrónica situada en la caja de registro común existente. La instalación de este sistema no requiere agujeros en la pared.

La caja de control electrónica puede conectarse a la red eléctrica o a un sistema doméstico.

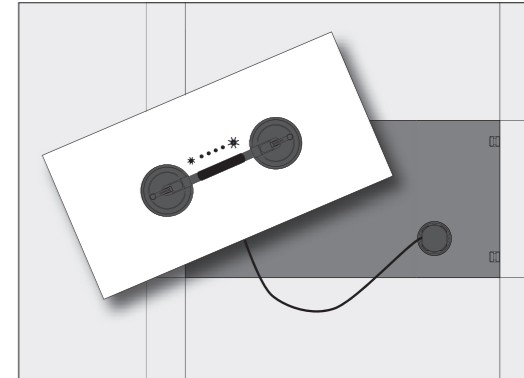

FÁCIL INSTALAÇÃO E ACESSO PARA MANUTENÇÃO

O revestimento cerâmico deve ser aplicado através de um sistema de fixação magnético, que permite fácil acesso para retirar e voltar a colocar a peça cerâmica, através da utilização de ventosas.

É também possível a utilização de um interruptor cerâmico – no formato 10x10 cm – sobre o revestimento preexistente (pinturas, outro revestimento cerâmico, etc).

EASY INSTALLATION AND ACCESS FOR MAINTENANCE

The wall tile ceramic is laid using a magnetic adhesion system, allowing easy access by using suckers to remove the piece and put it back again.

A ceramic switch - 10 x 10 cm format - may also be used on the existing coating (paintwork, other ceramic coatings, etc).

INSTALLATION ET ACCÈS POUR LA MAINTENANCE FACILES

Le revêtement céramique est appliqué grâce à un système de fixation magnétique, ce qui permet un accès facile grâce à l'utilisation de ventouses, pour enlever et replacer l'élément céramique.

Un commutateur en céramique - au format 10 x 10 cm - peut également être utilisé sur le revêtement existant (peinture, d'autres revêtements en céramique, etc).

FÁCIL INSTALACIÓN Y ACESSO PARA MANTENIMIENTO

El revestimiento cerámico se coloca a través de un sistema de fijación magnético, además de permitir un fácil acceso mediante ventosas para la retirada y recolocación de la pieza cerámica.

Un interruptor de cerámica - formato 10 x 10 cm - también se puede utilizar en el recubrimiento existente (pintura, otros revestimientos de cerámica, etc).

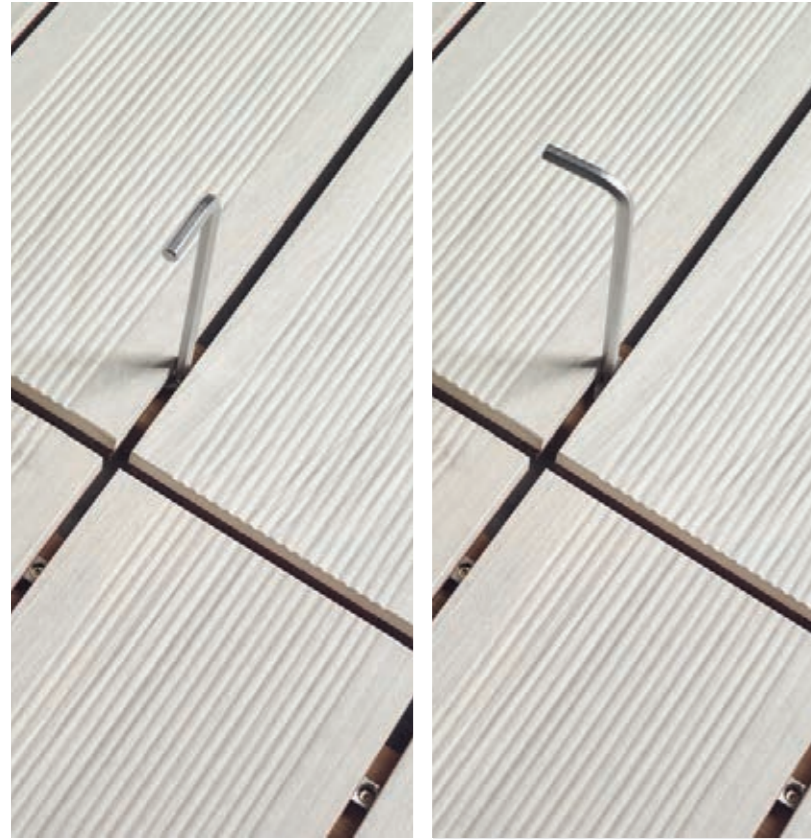

INSTALAÇÃO

O DECK SMART é composto por um deck cerâmico reforçado com um compósito no tardo, que lhe garante o aumento da resistência ao impacto e a facilidade de colocação sobre as estruturas de suporte dos pisos sobrelevados. A estrutura deverá apoiar o Deck em 3 ou 4 pontos da peça – extremidades e centro – de acordo com a intensidade do tráfego do espaço.

A montagem é simples e rápida e faz-se de forma sequencial: as linguetas são encaixadas na ranhura das peças cerâmicas de forma perpendicular, e o sistema é fixo à estrutura através do aparafusamento das linguetas à madeira ou ao alumínio (recomenda-se a utilização de parafusos em inox). Para fazer cortes deverá utilizar-se um cortador manual, com rolete de vidia. A utilização de uma serra de corte é suficiente para cortar o polímero.

Remover ou substituir uma peça: usar uma chave sextavada e fazer uma rotação de 90° na lingueta, de modo a ficar no sentido paralelo do deck. Não é necessário desaparafusar a lingueta, apenas rodá-la e desencaixar a peça da estrutura.

Limpeza e manutenção: utilizar água em abundância, detergente neutro e deixar secar ao ar. Utilizar uma escova de fibra dura, caso seja necessário remover alguma sujidade.

INSTALLATION

DECK SMART is composed of a ceramic deck reinforced with a compound in the reverse side, for greater impact resistance and easier laying on raised floors. The structure must support the Deck in 3 or 4 points – edges and middle – depending on the amount of traffic in the area.

Simple and quick assembly by sequential slotting: insert bolts into the grooves in the ceramic pieces perpendicularly and drive the screws into the wood or aluminium structure (inox screws are recommended).

To remove or replace one piece: turn the bolt 90° with a wrench so that it is parallel to the deck. Do not unscrew the bolt completely, you only need to turn it to unlatch the ceramic piece. Use manual scoring wheel tile vidia cutters for cutting. The saw cuts polymer well.

Cleaning and maintenance: rinse thoroughly, clean with neutral detergent and allow to air dry. Use a hard brush to remove dirt, if necessary.

POSE

DECK SMART est composé d'un deck céramique renforcé avec une composite sur la face arrière des lames assurant une résistance accrue aux chocs et une facilité de pose sur la structure portante des planchers surélevés. La structure devra porter le Deck sur 3 ou 4 points d'appui de la pièce – extrémités et milieu – selon l'intensité de circulation dans l'espace.

La pose est rapide, simple et séquentielle: les languettes sont placées perpendiculairement dans la rainure des pièces en céramique et le système est fixé à la structure portante par vissage des languettes au bois ou à l'aluminium (il est recommandé l'utilisation des vis en inox). Pour réaliser des coupes, utiliser un coupe-carrelage manuel avec rouleau en vidia. L'utilisation d'une scie de coupe est suffisante pour découper le polymère.

Pour enlever ou remplacer une pièce: utiliser une clé hexagonale et faire une rotation de 90° sur la languette, de manière à ce qu'elle soit parallèle au deck. Il n'est pas nécessaire de dévisser la languette, la faire tourner est suffisant pour retirer la pièce de la structure.

Nettoyage et entretien: Utiliser de l'eau en abondance, un détergent neutre et laisser sécher à l'air libre. Utiliser une brosse à fibres dures, si nécessaire, pour enlever la saleté.

INSTALACIÓN

DECK SMART está formado por una cubierta cerámica reforzada con un compuesto en la parte exterior que garantiza una mayor resistencia al impacto y facilidad de colocación sobre las estructuras de soporte de los pavimentos sobreelevados. La estructura deberá apoyar el Deck en 3 o 4 puntos de la pieza (las extremidades y el centro) de acuerdo con la intensidad del tráfico del espacio.

El montaje es sencillo y rápido y se lleva a cabo de manera secuencial: las lengüetas se encajan en la ranura de las piezas cerámicas de forma perpendicular y el sistema se fija a la estructura atornillando las lengüetas a la madera o al aluminio (si recomienda la utilización de tornillos en acero inoxidable). Para realizar cortes: deberá utilizarse un cortador manual, con rodil de vidia. Para cortar el polímero basta una sierra de corte.

Para retirar o sustituir una pieza: utilizar una llave hexagonal y rotar 90° la lengüeta, de forma que quede en sentido paralelo a la cubierta. No es necesario desatornillar la lengüeta, solo girarla y desencajar la pieza de la estructura.

Limpeza y mantenimiento: utilizar abundante agua, detergente neutro y dejar secar al aire. Utilizar una escoba de fibra dura, si fuera necesario eliminar alguna suciedad.



	Acabamento Finish Finition Acabado		Produtos Products Produits	Espessura Thickness Epaisseur Espesor (mm)	Caixa Box Paquet Caja			Europalette Europallet Europalette Europalette (t)			Camião 24 Ton. 24 Tonne Truck Camion 24 t Camión 24 Ton.			Contentor 20 Pés 20' Container Container 20 pieds Contenedor 20 Pies			
	Superficie Surface Superficie	Aresta Edge Arête Arista			Nº Peças No Pieces Nº Piezas	M2 Aprox. No of Sq. M. Approx. M2 Aprox.	Peso (Kg) Weight Kg Poids Kg Peso (Kg) (4)	Nº Caixas No Boxes Nº Cajas	M2 Aprox. No of Sq. M. Approx. M2 Aprox.	Peso (Kg) Weight Kg Poids Kg Peso (Kg) (5)	Nº Paletes No Pallets Nº Palés	M2 Aprox. No of Sq. M. Approx. M2 Aprox.	Peso (Kg) Weight Kg Poids Kg Peso (Kg) (5)	Nº Paletes No Pallets Nº Palés	M2 Aprox. No of Sq. M. Approx. M2 Aprox.	Peso (Kg) Weight Kg Poids Kg Peso (Kg) (5)	
	REVESTIMENTOS CERÂMICO VIDRADO · GLAZED WALL TILES IN WHITE BODY · FAÏENCE PÂTE BLANCHE · REVESTIMIENTOS CERÁMICOS VIDRIADOS																
20x40 8"x16"	Nat.	Nat.	Normal	Retro	8,4 ± 5 %	10	0,80	11,5	96	76,80	1 120	21	1 613	23 524	22	1 690	24 644
30x45 12"x18"	Nat.	Nat.	Normal	General	9,0 ± 5 %	11	1,50	23,9	48	72,00	1 166	20	1 440	23 316	21	1 512	24 482
30x60 12"x24"	Nat.	Nat.	Normal	General	9,0 ± 5 %	5	0,90	15,0	72	64,80	1 101	21	1 361	23 121	21	1 361	23 121
	Rect.	Nat.	Rect.	General	9,0 ± 5 %	5	0,90	14,5	72	64,80	1 065	22	1 426	23 430	21	1 361	22 365
30x90 12"x35"	Rect.	Nat.	Rect.	TETRIS GOLD/ MIRROR	9,0 ± 5 %	7	1,25	20,0	24	30,00	501	33	990	16 533	11	330	5 511
	Rect.	Nat.	Rect.	General	12,3 ± 0,5 mm	4	1,08	22,0	40	43,20	901	26	1 123	23 426	28	1 210	25 228
7,5x30 3"x12"	Nat.	Nat.	Normal	OXFORD	9,0 ± 5 %	40	0,90	14,0	66	59,40	945	25	1 485	23 625	11	653	10 395

	Acabamento Finish Finition Acabado		Produtos Products Produits	Espessura Thickness Epaisseur Espesor (mm)	Caixa Box Paquet Caja			Europalette Europallet Europalette Europalette (t)			Camião 24 Ton. 24 Tonne Truck Camion 24 t Camión 24 Ton.			Contentor 20 Pés 20' Container Container 20 pieds Contenedor 20 Pies			
	Superficie Surface Superficie	Aresta Edge Arête Arista			Nº Peças No Pieces Nº Piezas	M2 Aprox. No of Sq. M. Approx. M2 Aprox.	Peso (Kg) Weight Kg Poids Kg Peso (Kg) (4)	Nº Caixas No Boxes Nº Cajas	M2 Aprox. No of Sq. M. Approx. M2 Aprox.	Peso (Kg) Weight Kg Poids Kg Peso (Kg) (5)	Nº Paletes No Pallets Nº Palés	M2 Aprox. No of Sq. M. Approx. M2 Aprox.	Peso (Kg) Weight Kg Poids Kg Peso (Kg) (5)	Nº Paletes No Pallets Nº Palés	M2 Aprox. No of Sq. M. Approx. M2 Aprox.	Peso (Kg) Weight Kg Poids Kg Peso (Kg) (5)	
	GRÉS PORCELÂNICO ESMALTADO · GLAZED PORCELAIN TILES · GRÉS PORCELAINÉ ÉMAILLÉ · GRES PORCELÁNICO ESMALTADO																
15x75 6"x30"	Nat.	Nat.	Normal	General	8,5 ± 5 %	8	0,90	17,5	64	57,60	1 141	21	1 210	23 961	22	1 267	25 102
30x30 12"x12"	Nat.	Nat.	Normal	General	8,1 ± 5 %	10	0,90	17,0	64	57,60	1 109	21	1 210	23 289	22	1 267	24 398
	Rect.	Nat.	Rect.	General	8,1 ± 5 %	10	0,90	17,0	64	57,60	1 109	21	1 210	23 289	22	1 267	24 398
30x60 12"x24"	Nat.	Nat.	Normal	General	8,5 ± 5 %	5	0,90	17,0	48	43,20	837	28	1 210	23 436	30	1 296	25 110
	Rect. Matt Rect.	Nat.	Rect.	General	8,5 ± 5 %	5	0,90	19,0	60	54,00	1 161	20	1 080	23 220	24	1 296	27 864
	Rect. Matt Rect.	Nat.	Rect.	MARBLES	9,8 ± 5 %	5	0,90	20,7	48	43,20	1 015	23	994	23 336	26	1 123	26 380
	Pol.	Pol.	Rect.	General	8,0 ± 5 %	5	0,90	17,0	60	54,00	1 041	23	1 242	23 943	25	1 350	26 025
60x60 24"x24"	Pol.	Pol.	Rect.	MARBLES	9,8 ± 5 %	5	0,90	20,7	48	43,20	1 015	23	994	23 336	26	1 123	26 380
	Rect.	Nat.	Rect.	General	8,5 ± 5 %	4	1,44	28,7	36	51,84	1 054	22	1 140	23 192	24	1 244	25 301
	Rect. Matt Rect.	Nat.	Rect.	MARBLES	9,8 ± 5 %	4	1,44	33,0	32	46,08	1 077	22	1 014	23 694	25	1 152	26 925
	Pol.	Pol.	Rect.	General	8,0 ± 5 %	4	1,44	26,7	36	51,84	982	24	1 244	23 573	25	1 296	24 555
60 x 120 24" x 47"	Pol.	Pol.	Rect.	MARBLES	9,8 ± 5 %	4	1,44	33,0	32	46,08	1 077	22	1 014	23 694	25	1 152	26 925
	Matt Rect.	Nat.	Rect.	ABSOLUT BLACK, BALTIC GREY, EMPERADOR BROWN, STATUARIO WHITE	9,8 ± 5 %	2	1,44	33,0	27	38,88	912	23	894	20 976	26	1 011	23 712
	Rect.	Nat.	Rect.	VENEZIA	9,8 ± 5 %	2	1,44	33,0	30	43,20	1 011	23	994	23 253	25	1 080	25 275
	Pol.	Pol.	Rect.	ABSOLUT BLACK, BALTIC GREY, EMPERADOR BROWN, STATUARIO WHITE	9,8 ± 5 %	2	1,44	33,0	27	38,88	912	25	972	22 800	26	1 011	23 712
45x45 18"x18"	Pol.	Pol.	Rect.	VENEZIA	9,8 ± 5 %	2	1,44	31,0	30	43,20	951	25	1 080	23 775	26	1 123	24 726
	Nat.	Nat.	Normal	General	8,2 ± 5 %	6	1,22	24,0	34	41,48	837	28	1 161	23 436	30	1 244	25 110
90 x 90 35" x 35"	Matt Rect.	Nat.	Rect.	MARBLES	10,5 ± 0,5 mm	2	1,62	38,0	24	38,88	967	23	894	22 241	26	1 011	25 142
	Pol.	Pol.	Rect.	MARBLES	10,5 ± 0,5 mm	2	1,62	38,0	24	38,88	967	23	894	22 241	26	1 011	25 142



	Acabamento Finish Finition Acabado		Produtos Products Produits	Espessura Thickness Epaisseur Espesor (mm)	Caixa Box Paquet Caja			Europalette Europallet Europalette Europalette (t)			Camião 24 Ton. 24 Tonne Truck Camion 24 t Camión 24 Ton.			Contentor 20 Pés 20' Container Container 20 pieds Contenedor 20 Pies			
	Superficie Surface Superficie	Aresta Edge Arête Arista			Nº Peças No Pieces Nº Piezas	M2 Aprox. No of Sq. M. Approx. M2 Aprox.	Peso (Kg) Weight Kg Poids Kg Peso (Kg) (4)	Nº Caixas No Boxes Nº Cajas	M2 Aprox. No of Sq. M. Approx. M2 Aprox.	Peso (Kg) Weight Kg Poids Kg Peso (Kg) (5)	Nº Paletes No Pallets Nº Palés	M2 Aprox. No of Sq. M. Approx. M2 Aprox.	Peso (Kg) Weight Kg Poids Kg Peso (Kg) (5)	Nº Paletes No Pallets Nº Palés	M2 Aprox. No of Sq. M. Approx. M2 Aprox.	Peso (Kg) Weight Kg Poids Kg Peso (Kg) (5)	
	DECK SMART																
15x120 6" x 47"	Rect.	Nat.	Rect.	DECK SMART	25,0 ± 0,5 mm	4	0,72	21,9	18	12,96	430	48	622	20 650	40	518	17 208
	REVICOMFORT																
60x60 24" x 24"	Rect.	Nat.	Rect.	REVICOMFORT	11,5 ± 0,5 mm	3	1,08	24,0	36	38,88	885	27	1 050	23 895	28	1 089	24 780

Características Técnicas

Technical Characteristics

CARACTERÍSTICAS TÉCNICAS TECHNICAL CHARACTERISTICS MÉTODOS DE ENSAIO / TEST METHODS		REVESTIMENTOS CERÂMICO VIDRADO GLAZED WALL TILES IN WHITE BODY GRUPO - GROUP BIII GL (EN 14411)			GRÉS PORCELÂNICO ESMALTADO GLAZED PORCELAIN TILES GRUPO - GROUP BIIa GL (EN 14411) (c)			
		Norma / Standard	Natural	Rect	Norma / Standard	Natural	Matt Rect / Rect	Polido
ISO 10545 - 2	Comprimento e largura Length and width	± 0,5 %	± 0,3 %	± 0,2 %	± 0,5 %	± 0,2 %	± 0,1 %	± 0,1 %
	Desvio da espessura média para a espessura de fabrico Deviation of mean thickness from manufacturing thickness	± 10 %	± 5 %	± 5 %	± 5 %	± 5 %	± 5 %	± 5 %
	Retilinearidade dos lados (lados da face principal) Straightness of the sides (sides of the main face)	± 0,3 %	± 0,3 %	± 0,2 %	± 0,5 %	± 0,3 %	± 0,2 %	± 0,2 %
	Ortogonalidade Orthogonality	± 0,5 %	± 0,3 %	± 0,2 %	± 0,6 %	± 0,3 %	± 0,2 %	± 0,2 %
	Planaridade da superfície Surface flatness	+ 0,5 % - 0,3 %	+ 0,3 % - 0,2 %	+ 0,3 % - 0,2 %	± 0,5 %	± 0,3 %	± 0,3 %	± 0,2 %
Qualidade da superfície (% isenta de defeitos) Surface quality (% defect-free)	≥ 95%	Cumprido Compliant	Cumprido Compliant	≥ 95%	Cumprido Compliant	Cumprido Compliant	Cumprido Compliant	Cumprido Compliant
ISO 10545 - 3	Absorção de água (método de ebulição) Water absorption (boiling method)	> 10 %	> 16 % - 19%	> 16 % - 19%	< 0,5 %	< 0,5 %	< 0,5 %	< 0,5 %
ISO 10545 - 4	Resistência à Flexão (N): Bending Strength (N):	> 600	> 600	> 600				
	9,8 mm ≤ Espessura < 10,5 mm 9,8 mm ≤ Thickness < 10,5 mm	-	-	-	≥ 1300	> 3500	> 3500	> 3500
	7,5 mm ≤ Espessura < 8,5 mm 7,5 mm ≤ Thickness < 8,5 mm (d)	-	-	-	≥ 1300	> 2000	> 2000	> 2000
Módulo de ruptura (N / mm ²) Rupture modulus (N / mm ²)	> 15	> 15	> 15	> 35	> 40	> 40	> 40	
ISO 10545 - 7	Resistência à abrasão (grupos PEI) Resistance to deep abrasion (PEI groups) (b)	-	-	-	Grupos PEI PEI groups II - III - IV - V	Grupos PEI PEI groups II - III - IV	-	-
ISO 10545 - 8	Coefficiente de dilatação térmica linear (da temperatura ambiente até 100 °C) Coefficient of linear thermal expansion (with atmospheric temperature up to 100 °C)	Método de ensaio disponível Test method available	Ensaio disponível Test available	Ensaio disponível Test available	Método de ensaio disponível Test method available	≤ 8,0x10 ⁻⁶ /°C	≤ 8,0x10 ⁻⁶ /°C	≤ 8,0x10 ⁻⁶ /°C
ISO 10545 - 11	Resistência à fendilhagem (vidrados) Cracking resistance (glazed)	Exigida Required	Resiste Resistant	Resiste Resistant	-	-	-	-
ISO 10545 - 12	Resistência ao gelo Resistance to frost	-	-	-	Exigida Required	Sem defeitos visíveis Resistant	Sem defeitos visíveis Resistant	Sem defeitos visíveis Resistant
ISO 10545 - 13 (a)	Resistência a ácidos e bases de alta concentração Resistance to acids and high concentration bases	Método de ensaio disponível Test method available	Ensaio disponível Test available	Ensaio disponível Test available	Método de ensaio disponível Test method available	Classe GHA Type GHA	Classe GHA Type GHA	Ensaio disponível Test available
	Resistência a ácidos e bases de baixa concentração Resistance to low concentrations of acids and alkalis	Método de ensaio disponível Test method available	Ensaio disponível Test available	Ensaio disponível Test available	Método de ensaio disponível Test method available	Classe GLA Type GLA	Classe GLA Type GLA	Classe GLA Type GLA
ISO 10545 - 14	Resistência a produtos químicos domésticos e aditivos para água de piscinas Resistance to household chemicals and swimming pool water additives	Min. Classe GB Min. Type GB	Classe GA Type GA	Classe GA Type GA	Min. Classe GB Min. Type GB	Classe GA Type GA	Classe GA Type GA	Ensaio disponível Test available
EN 13823 - EN 9239-1	Resistência a manchas Resistance to staining	Método de ensaio disponível Test method available	Min. Classe 4 Min. Type 4	Min. Classe 4 Min. Type 4	Min. Classe 3 Min. Type 3	Classe 5 Type 5	Classe 5 Type 5	Min. Classe 3 Min. Type 3
EN 13823 - EN 9239-1	Reação ao fogo Reaction to fire	A1 _{FL}	CLASSE A1 TYPE A1	CLASSE A1 TYPE A1	A1 _{FL}	CLASSE A1 _{FL} /CLASSE A1 TYPE A1 _{FL} /TYPE A1	CLASSE A1 _{FL} /CLASSE A1 TYPE A1 _{FL} /TYPE A1	CLASSE A1 _{FL} /CLASSE A1 TYPE A1 _{FL} /TYPE A1

NOTAS · NOTES

(a) Exceto ao ácido fluorídrico.
Except hydrofluoric acid.

(b) Resistência à Abrasão (Grupos PEI):
** Pavimento destinado a locais com tráfego ligeiro. (Equivalente a PEI II / G2)
*** Pavimento destinado a locais com tráfego moderado. (Equivalente a PEI III / G3)
**** Pavimento destinado a locais com tráfego médio-forte. (Equivalente a PEI IV / G4)
***** Pavimento destinado a locais com tráfego forte, excepto locais públicos de tráfego intenso (Equivalente a PEI V / G5)
Recomendamos a colocação de um tapete nas áreas de comunicação com o exterior (entrada, acesso ao jardim ou terraços), a fim de eliminar as areias e matérias abrasivas.

(c) Resistance to abrasion (PEI Groups):
** Floor Tiles for light traffic areas. (Equivalent to PEI II / G2)
*** Floor Tiles for regular traffic areas. (Equivalent to PEI III / G3)
**** Floor Tiles for areas of considerable traffic. (Equivalent to PEI IV / G4)
***** Floor Tiles for heavy traffic areas, except for intensively used public places. (Equivalent to PEI V / G5)
We recommend that a doormat be placed at the entrance of any doors leading outside (e.g. front door, garden or terrace doorways), in order to remove any abrasive particles (e.g.: sand).

(d) Os produtos podem ser aplicados em piso radiante.
The products can be used with underfloor heating.

(e) Resistência à flexão do formato 15x75x0,85cm: > 1500 N
Bending strength of size 15x75x0.85 cm: > 1500 N

Características Técnicas

Technical Characteristics

CARACTERÍSTICAS TÉCNICAS TECHNICAL CHARACTERISTICS MÉTODOS DE ENSAIO / TEST METHODS		GRÉS PORCELÂNICO TÉCNICO FULL BODY PORCELAIN TILES GRUPO - GROUP BIIa UGL (EN 14411) (c)			
		Norma / Standard	Natural Matt Nat	Matt Rect	Polido / Polished
ISO 10545 - 2	Comprimento e largura Length and width	± 0,5%	± 0,2%	± 0,1%	± 0,1%
	Desvio da espessura média para a espessura de fabrico Deviation of mean thickness from manufacturing thickness	± 5%	± 5%	± 5%	± 5%
	Retilinearidade dos lados (lados da face principal) Straightness of the sides (sides of the main face)	± 0,5%	± 0,3%	± 0,2%	± 0,2%
	Ortogonalidade Orthogonality	± 0,6%	± 0,3%	± 0,2%	± 0,2%
	Planaridade da superfície Surface flatness	± 0,5%	± 0,3%	± 0,3%	± 0,2%
Qualidade da superfície (% isenta de defeitos) Surface quality (% defect-free)	≥ 95%	Cumprido Compliant	Cumprido Compliant	Cumprido Compliant	
ISO 10545-3	Absorção de água Water absorption	< 0,5%	< 0,05%	< 0,05%	< 0,05%
ISO 10545-4	Módulo de Ruptura (N/mm ²) Rupture modulus (N/mm ²)	> 35	> 45	> 45	> 45
	Resistência à Flexão (N): Bending Strength (N):				
	Espeçura ≥ 14,0 mm Thickness ≥ 14,0 mm	≥ 1300	> 6500	> 6500	> 6500
9,8 mm ≤ Espessura < 10,5 mm 9,8 mm ≤ Thickness < 10,5 mm	≥ 1300	> 3500	> 3500	> 3500	
7,5 mm ≤ Espessura < 8,5 mm 7,5 mm ≤ Thickness < 8,5 mm	≥ 1300	> 2000	> 2000	> 2000	
ISO 10545-6	Resistência à abrasão profunda (Volume removido/mm ³) Resistance to deep abrasion (Removed volume/mm ³)	< 175	< 120	< 120	< 120
ISO 10545-8	Coefficiente de Dilatação Térmica Linear (da temperatura ambiente até 100 °C) Coefficient of Linear Thermal Expansion (with atmospheric temperature up to 100 °C)	Método de ensaio disponível Test method available	≤ 8,0x10 ⁻⁶ / °C	≤ 8,0x10 ⁻⁶ / °C	≤ 8,0x10 ⁻⁶ / °C
ISO 10545-9	Resistência ao choque térmico Resistance to thermal shock	Exigida Required	Resiste Resistant	Resiste Resistant	Resiste Resistant
ISO 10545-12	Resistência ao gelo Resistance to frost	Exigida Required	Sem defeitos visíveis Without visible defects	Sem defeitos visíveis Without visible defects	Sem defeitos visíveis Without visible defects
ISO 10545-13 (a)	Resistência a Ácidos e Bases de Alta Concentração Resistance to Acids and High Concentration Bases	O produtor declara à classificação The producer declares the classification	Classe ULA Type ULA (b)	Classe ULA Type ULA (b)	Ensaio disponível Test available
	Resistência a Ácidos e Bases de Baixa Concentração Resistance to low concentrations of acids and alkalis	Min. Classe UB Min. Type UB	Classe ULA Type ULA (b)	Classe ULA Type ULA (b)	Classe ULA Type ULA
ISO 10545-14	Resistência a Produtos Químicos Domésticos e Aditivos para Água de Piscinas Resistance to Household Chemicals and Swimming pool water additives	Min. Classe UB Min. Type UB	Classe UA Type UA	Classe UA Type UA	Ensaio disponível Test available
DIN 51130	Resistência a manchas Resistance to staining	Método de ensaio disponível Test method available	Classe 5 Type 5	Classe 5 Type 5	Min. Classe 3 Min. Type 3
DIN 51097	Resistência a manchas Resistance to staining	Método de ensaio disponível Test method available	Máx R13 Max R13	Ensaio disponível Test available	Ensaio disponível Test available
ENV 12633	Resistência ao escorregamento Anti slip resistance	Método de ensaio disponível Test method available	Máx C Max C	Ensaio disponível Test available	Ensaio disponível Test available
BS 7976	Resistência ao escorregamento Anti slip resistance	Método de ensaio disponível Test method available	Máx classe 3 Max type 3	Ensaio disponível Test available	Ensaio disponível Test available
ANSI A137.1	Resistência ao escorregamento Anti slip resistance	Método de ensaio disponível Test method available (DCOF) (d)	Método de ensaio disponível Test method available	O Produtor declara The producer declares	O Produtor declara The producer declares
UPEC C5TB	Resistência ao choque pesado Resistance to heavy shock	Nível 0 a 5 Level 0 to 5	Nível 3 Level 3	Nível 3 Level 3	Nível 3 Level 3
EN 13823 - EN 9239-1	Reação ao fogo Reaction to fire	A1 _{FL}	Classe A1 _{FL} / Classe A1 Type A1 _{FL} / Type A1	Classe A1 _{FL} / Classe A1 Type A1 _{FL} / Type A1	Classe A1 _{FL} / Classe A1 Type A1 _{FL} / Type A1

NOTAS · NOTES

(a) Exceto ao ácido fluorídrico.
Except hydrofluoric acid.

(b) Exceto Coleção METALLIC: Classe UB e UHB.
Except metallic Collection: Type UB and UHB.

(c) Os produtos podem ser aplicados em piso radiante.
The products can be used with underfloor heating.

(d) DCOF ≥ 0,42 espaços interiores expectável de serem utilizados húmidos.
DCOF ≥ 0.42 interior spaces expected to be used wet.

1. Para os produtos com relevo, dado serem superfícies não planas, não são considerados os valores de curvatura e de empeno.
2. As especificações técnicas são válidas unicamente para os produtos classificados de 1ª escolha. O incumprimento dos valores indicados em outras classificações comerciais não será motivo de reclamação.
3. Todos os produtos, nomeadamente do grupo BIIa UGL, cumprem os requisitos da norma EN 14411. Os valores correspondentes às características técnicas dos acabamentos Natural e Polido representam valores de referência de Inspeção e ensaio.
4. Este quadro indica os valores considerados mais relevantes sobre as Características Técnicas do Porcelanato. No entanto, no caso de ser necessária alguma informação adicional, solicitamos o contato para: revigres@revigres.pt

1. In products with structured surfaces, curving and bending values are not considered.
2. Technical specifications are only valid for the products classified as 1st choice. The non-performance of the indicated values for other commercial classifications will not be considered as grounds for complaint.
3. All products, including that of the BIIa UGL group, fulfil the requirements of EN 14411. The figures of the technical features of the Natural and Polished finishes are the reference values for inspection and testing.
4. This table lists the most relevant Technical Characteristics for Full Body Porcelain Tiles. For more information please contact us at: revigres@revigres.pt

Caracteristiques Techniques

Características Técnicas

	MÉTHODES D'ESSAI MÉTODOS DE PRUEBA	FAÏENCE PÂTE BLANCHE REVESTIMIENTOS CERÁMICOS VIDRIADOS GRUPE - GRUPO BII GL (EN 14411)			GRÈS PORCELAINÉ ÉMAILLÉ GRES PORCELÁNICO ESMALTADO GRUPE - GRUPO BII GL (EN 14411) (c)			
		Standard / Estándar	Naturel / Natural	Rect	Standard / Estándar	Naturel / Natural	Matt Rect / Rect	Polido
ISO 10545 - 2	Longueur et largeur Longitud y anchura	± 0,5 %	± 0,3 %	± 0,2 %	± 0,5 %	± 0,2 %	± 0,1 %	± 0,1 %
	Écart entre l'épaisseur moyenne et l'épaisseur standard Desvío del grosor medio con respecto grosor de fabricación	± 10 %	± 5 %	± 5 %	± 5 %	± 5 %	± 5 %	± 5 %
	Rectilinéarité des côtés (côtés de la face principale) Rectilinearidad de los lados (lados de la cara principal)	± 0,3 %	± 0,3 %	± 0,2 %	± 0,5 %	± 0,3 %	± 0,2 %	± 0,2 %
	Orthogonalité ortogonalidad	± 0,5 %	± 0,3 %	± 0,2 %	± 0,6 %	± 0,3 %	± 0,2 %	± 0,2 %
	Planéité de la surface Planeidad de la superficie	+ 0,5 % - 0,3 %	+ 0,3 % - 0,2 %	+ 0,3 % - 0,2 %	± 0,5 %	± 0,3 %	± 0,3 %	± 0,2 %
Qualité de la surface (% sans défauts) Calidad de la superficie (% exenta de defectos)	≥ 95%	Respect norme Cumple	Respect norme Cumple	≥ 95%	Respect norme Cumple	Respect norme Cumple	Respect norme Cumple	
ISO 10545 - 3	Absorption d'eau (méthode d'ébullition) Absorción del agua (método de ebullición)	> 10 %	> 16 % - 19%	> 16 % - 19%	< 0,5 %	< 0,5 %	< 0,5 %	< 0,5 %
ISO 10545 - 4	Résistance à la flexion (N) Resistencia a la flexión (N)	> 600	> 600	> 600				
	9,8 mm ≤ Épaisseur < 10,5 mm 9,8 mm ≤ Grosor < 10,5 mm	-	-	-	≥ 1300	> 3500	> 3500	> 3500
	7,5 mm ≤ Épaisseur < 8,5 mm (d) 7,5 mm ≤ Grosor < 8,5 mm	-	-	-	≥ 1300	> 2000	> 2000	> 2000
Module de rupture (N / mm²) Módulo de ruptura (N / mm²)	> 15	> 15	> 15	> 35	> 40	> 40	> 40	
ISO 10545 - 7	Résistance à l'abrasion (groupes PEI) Resistencia a la abrasión (grupos PEI)	-	-	-	Groupes PEI Grupos PEI II - III - IV - V	Groupes PEI Grupos PEI II - III - IV - V	-	-
ISO 10545 - 8	Coefficient de dilatation thermique linéaire (de la température ambiante jusqu'à 100°C) Coeficiente de dilatación térmica lineal (de la temperatura ambiente hasta 100 °C)	Méthode d'essai disponible Método de ensayo disponible	Essai disponible Ensayo disponible	Essai disponible Ensayo disponible	Méthode d'essai disponible Método de ensayo disponible	≤ 8,0x10 ⁻⁴ /°C	≤ 8,0x10 ⁻⁴ /°C	≤ 8,0x10 ⁻⁴ /°C
ISO 10545 - 11	Résistance au treillisage Resistencia al cuarteado (vidriados)	Requise Exigida	Résistant Resistente	Résistant Resistente	-	-	-	-
ISO 10545 - 12	Résistance au gel Resistencia al hielo	-	-	-	Exigida Required	Sans défaut apparent Sin defectos visibles	Sans défaut apparent Sin defectos visibles	Sans défaut apparent Sin defectos visibles
ISO 10545 - 13 (a)	Résistance aux acides et aux bases à haute concentration resistencia a ácidos y bases de alta concentración	Méthode d'essai disponible Método de ensayo disponible	Essai disponible Ensayo disponible	Essai disponible Ensayo disponible	Méthode d'essai disponible Método de ensayo disponible	Classe GHA Clase GHA	Classe GHA Clase GHA	Essai disponible Ensayo disponible
	Résistance aux acides et aux bases à faible concentration Resistencia a ácidos y bases de baja concentración	Méthode d'essai disponible Método de ensayo disponible	Essai disponible Ensayo disponible	Essai disponible Ensayo disponible	Méthode d'essai disponible Método de ensayo disponible	Classe GLA Clase GLA	Classe GLA Clase GLA	Essai disponible Ensayo disponible
ISO 10545 - 14	Résistance aux produits chimiques ménagers et aux additifs pour eau de piscine: dalles vitrées Resistencia a productos químicos domésticos y aditivos para agua de piscinas: ladrillos vidriados	Min. Classe GB Min. Type GB	Classe GA Clase GA	Classe GA Clase GA	Min. Classe GB Min. Clase GB	Classe GA Clase GA	Classe GA Clase GA	Essai disponible Ensayo disponible
ISO 10545 - 14	Résistance aux taches Resistencia antimanchas	Méthode d'essai disponible Método de ensayo disponible	Min. Classe 4 Min. Clase 4	Min. Classe 4 Min. Clase 4	Min. Classe 3 Min. Type 3	Classe 5 Clase 5	Classe 5 Clase 5	Min. Classe 3 Min. Clase 3
EN 13823 . EN 9239-1	Réaction au feu Reacción al fuego	A1 _{FL}	Classe A1 Clase A1	Classe A1 Clase A1	A1 _{FL}	CLASSE A1 _{FL} /CLASSE A1 CLASE A1 _{FL} /CLASE A1	CLASSE A1 _{FL} /CLASSE A1 CLASE A1 _{FL} /CLASE A1	CLASSE A1 _{FL} /CLASSE A1 CLASE A1 _{FL} /CLASE A1

NOTES - NOTAS

- (a) Sauf à l'acide fluorhydrique.
Excepto al ácido fluorhídrico.
- (b) Résistance à l'abrasion (Groupes PEI):
** Pavimento destinado a lugares con tráfico ligero. (Equivalente a PEI II / G2)
*** Revêtement de sol destiné aux endroits à faible circulation. (Équivalent à PEI II / G2)
**** Revêtement de sol destiné aux endroits à circulation modérée. (Équivalent à PEI III / G3)
***** Revêtement de sol destiné aux endroits à circulation moyenne et intense. (Équivalent à PEI IV / G4)
***** Revêtement de sol destiné aux endroits à circulation intense, à l'exception des lieux publics intense (Équivalent à PEI V / G5)
Nous vous recommandons la pose d'un tapis sur les zones de communication avec l'extérieur (entrée, accès au jardin ou aux terrasses), afin d'éliminer les grains de sable et les matières abrasives.
- (c) Resistencia a la Abrasión (Grupos PEI):
** Pavimento destinado a lugares con tráfico ligero. (Equivalente a PEI II / G2)
*** Pavimento destinado a lugares con tráfico moderado. (Equivalente a PEI III / G3)
**** Pavimento destinado a lugares con tráfico medio-fuerte. (Equivalente a PEI IV / G4)
***** Pavimento destinado a lugares con tráfico fuerte, excepto lugares públicos de tráfico intenso (Equivalente a PEI V / G5).
Recomendamos la colocación de una alfombra en las áreas de comunicación con el exterior (entrada, acceso al jardín o a las terrazas), con el fin de eliminar las arenas y los materiales abrasivos.
- (d) Les produits peuvent être posés sur sols chauffants.
Los productos pueden aplicarse en suelos radiantés.
- (e) Résistance à la flexion du format 15x75x0,85 cm : >1500 N
Resistencia a la flexión del formato 15x75x0,85 cm : >1500 N

Caracteristiques Techniques

Características Técnicas

	MÉTHODES D'ESSAI MÉTODOS DE PRUEBA	GRÈS PORCELAINÉ PLEINE MASSE GRES PORCELÁNICO TÉCNICO GRUPE - GRUPO BIIa UGL (EN 14411) (c)			
		Standard / Estándar	Naturel / Natural	Matt Rect	Poli / Polido
ISO 10545 - 2	Longueur et largeur Longitud y anchura	± 0,5%	± 0,2%	± 0,1%	± 0,1%
	Écart entre l'épaisseur moyenne et l'épaisseur standard Desvío del grosor medio con respecto grosor de fabricación	± 5%	± 5%	± 5%	± 5%
	Rectilinéarité des côtés (côtés de la face principale) Rectilinearidad de los lados (lados de la cara principal)	± 0,5%	± 0,3%	± 0,2%	± 0,2%
	Orthogonalité Ortogonalidad	± 0,6%	± 0,3%	± 0,2%	± 0,2%
	Planéité de la surface Planeidad de la superficie	± 0,5%	± 0,3%	± 0,3%	± 0,2%
	Qualité de la surface (% sans défauts) Calidad de la superficie (% exenta de defectos)	≥ 95%	Respecte norme Cumple	Respecte norme Cumple	Respecte norme Cumple
	ISO 10545-3	Absorption d'eau Absorción del agua	< 0,5%	< 0,05%	< 0,05%
ISO 10545-4	Module de rupture (N/mm²) Módulo de Ruptura (N/mm²)	> 35	> 45	> 45	> 45
	Résistance à la Flexion (N) Resistencia a la Flexión (N)				
	Épaisseur ≥ 14,0 mm Grosor ≥ 14,0 mm	≥ 1300	> 6500	> 6500	> 6500
	9,8 mm ≤ Épaisseur < 10,5 mm 9,8 mm ≤ Grosor < 10,5 mm	≥ 1300	> 3500	> 3500	> 3500
7,5 mm ≤ Épaisseur < 8,5 mm 7,5 mm ≤ Grosor < 8,5 mm	≥ 1300	> 2000	> 2000	> 2000	
ISO 10545-6	Résistance à l'abrasion profonde (volume extrait, mm³) Resistencia a la abrasión profunda (Volumen extraído/mm³)	< 175	< 120	< 120	< 120
ISO 10545-8	Coefficient de dilatation thermique linéaire (de la température ambiante jusqu'à 100°C) Coeficiente de dilatación térmica lineal (de la temperatura ambiente hasta 100 °C)	Méthode d'essai disponible Método de ensayo disponible	≤ 8,0x10 ⁻⁴ / °C	≤ 8,0x10 ⁻⁴ / °C	≤ 8,0x10 ⁻⁴ / °C
ISO 10545-9	Résistance aux chocs thermiques Resistencia al impacto térmico	Requise Exigida	Résistant Resistente	Résistant Resistente	Résistant Resistente
ISO 10545-12	Résistance au gel Resistencia al hielo	Requise Exigida	Sans défaut apparent Sin defectos visibles	Sans défaut apparent Sin defectos visibles	Sans défaut apparent Sin defectos visibles
ISO 10545-13 (a)	Résistance aux acides et aux bases à haute concentration Resistencia a ácidos y bases de alta concentración	Le producteur déclare la classification El productor declara la clasificación	Classe ULA Clase ULA (b)	Classe ULA Clase ULA (b)	Essai disponible Test available
	Résistance aux acides et aux bases à faible concentration Resistencia a ácidos y bases de baja concentración	Le producteur déclare la classification El productor declara la clasificación	Classe ULA Clase ULA (b)	Classe ULA Clase ULA (b)	Essai disponible Test available
ISO 10545-14	Résistance aux produits chimiques ménagers et aux additifs pour eau de piscine Resistencia a productos químicos domésticos y aditivos para agua de piscinas	Min. Classe UB Min. Type UB	Classe UA Clase UA	Classe UA Clase UA	Essai disponible Test available
ISO 10545-14	Résistance aux taches Resistencia antimanchas	Méthode d'essai disponible Método de ensayo disponible	Classe 5 Clase 5	Classe 5 Clase 5	Min. Classe 3 Min. Clase 3
DIN 51130	Résistance aux taches Resistencia antimanchas	Máx R13 Max R13	Essai disponible Ensayo disponible	Essai disponible Ensayo disponible	-
DIN 51097	Résistance aux taches Resistencia antimanchas	Máx C Max C	Essai disponible Ensayo disponible	Essai disponible Ensayo disponible	-
ENV 12633	Résistance à la glissance Resistencia antideslizamiento	Máx classe 3 Max type 3	Essai disponible Ensayo disponible	Essai disponible Ensayo disponible	-
BS 7976	Résistance à la glissance Resistencia antideslizamiento	Méthode d'essai disponible Método de ensayo disponible	Le producteur déclare El productor declara	Le producteur déclare El productor declara	-
ANSI A137.1	Résistance à la glissance Resistencia antideslizamiento	Méthode d'essai disponible Método de ensayo disponible (DCOF) (d)	Le producteur déclare El productor declara	DCOF ≥ 0.42	-
UPEC CSTB	Tenue au choc lourd Resistencia a impactos pesados	Niveau 0 a 5 Nivel 0 to 5	Niveau 3 Nivel 3	Niveau 3 Nivel 3	-
EN 13823 . EN 9239-1	Réaction au feu Reacción al fuego	A1 _{FL}	Classe A1 _{FL} / Classe A1 Clase A1 _{FL} / Clase A1	Classe A1 _{FL} / Classe A1 Clase A1 _{FL} / Clase A1	Classe A1 _{FL} / Classe A1 Clase A1 _{FL} / Clase A1

NOTES - NOTAS

- (a) Sauf à l'acide fluorhydrique.
Excepto al ácido fluorhídrico.
- (b) Sauf Collection Metallic: Classe UB et UHB.
Excepto Collection Metallic: Classe UB y UHB.
- (c) Les produits peuvent être posés sur sols chauffants.
Los productos pueden aplicarse en suelos radiantés.
- (d) DCOF ≥ 0.42 Espaces intérieurs présumés d'être utilisés humides.
DCOF ≥ 0.42 espacios interiores que presumiblemente se vayan a utilizar húmedos.
1. Pour les produits à reliefs, étant donné qu'il s'agit de surfaces non planes, les valeurs de bombement et de gauchissement ne sont pas considérées.
2. Les spécifications techniques ne sont valables que pour les produits classés de 1er choix. Le non respect des valeurs indiquées pour d'autres classifications commerciales ne pourra donner lieu à réclamation.
3. Ce tableau indique les valeurs jugées les plus pertinentes des caractéristiques techniques du grès cérame porcelainé. Toutefois, pour toutes informations complémentaires, la direction technique reste à votre disposition. Contactez-nous à: revigres@revigres.pt
1. Para los productos con relieve, al tratarse de superficies no planas, no se considerarán los valores de curvatura y deformación.
2. Las características técnicas son válidas únicamente para los productos clasificados como 1ª opción. El incumplimiento de los valores indicados para otras categorías comerciales no podrá ser motivo de reclamación.
3. Este cuadro indica los valores considerados más relevantes sobre las Características Técnicas del Porcelanato. Para más información, pueden contactar con: revigres@revigres.pt

Certificados

Certificates _ Certificats _ Certificados

A Revigrés tem a quádrupla certificação dos seus sistemas de gestão integrados, nos seguintes referenciais: Qualidade; Ambiente; Responsabilidade Social; Investigação, Desenvolvimento e Inovação.

Revigrés has quadruple certification of its integrated management systems in terms of the following standards: Quality; Environment; Social Accountability; Research, Development and Innovation.

Revigrés possède une quadruple certification de ses systèmes de gestion intégrés dans les référentiels suivants: Qualité; Environnement; Responsabilité Sociale; Recherche, Développement et Innovation.

Revigrés cuenta con una quádruple certificación de sus sistemas de gestión integrados, en las siguientes categorías: Calidad; Medio Ambiente; Responsabilidad Social; Investigación, Desarrollo e Innovación.



NP EN ISO 9001: 2015
1.ª empresa do setor de revestimentos e pavimentos cerâmicos CERTIFICADA PELO SISTEMA DE GESTÃO DA QUALIDADE

NP EN ISO 9001: 2015
1st company in the wall and floor ceramic tiles sector to be CERTIFIED FOR ITS QUALITY MANAGEMENT SYSTEM

NP EN ISO 9001: 2015
1^{re} entreprise du secteur des revêtements de sol et muraux en céramique CERTIFIÉE POUR SON SYSTÈME DE GESTION DE LA QUALITÉ

NP EN ISO 9001: 2015
1.ª empresa del sector de revestimientos y pavimentos cerámicos CERTIFICADA POR EL SISTEMA DE GESTIÓN DE LA CALIDAD

NP EN ISO 14001 : 2015
CERTIFICAÇÃO DO SISTEMA DE GESTÃO AMBIENTAL

NP EN ISO 14001 : 2015
ENVIRONMENTAL MANAGEMENT SYSTEM CERTIFICATION

NP EN ISO 14001 : 2015
CERTIFICATION DU SYSTÈME DE GESTION DE L'ENVIRONNEMENT

NP EN ISO 14001 : 2015
CERTIFICACIÓN DEL SISTEMA DE GESTIÓN AMBIENTAL

NP 4469-1: 2008
1.ª e única empresa do setor cerâmico CERTIFICADA PELO SISTEMA DE GESTÃO DA RESPONSABILIDADE SOCIAL

NP 4469-1: 2008
1st and only company in the ceramic sector CERTIFIED BY SOCIAL ACCOUNTABILITY MANAGEMENT SYSTEM

NP 4469-1: 2008
1^{re} et unique entreprise du secteur céramique CERTIFIÉE POUR SYSTÈME DE GESTION DE LA RESPONSABILITÉ SOCIALE

NP 4469-1: 2008
1.ª y única empresa del sector cerámico certificada por el SISTEMA DE GESTIÓN DE RESPONSABILIDAD SOCIAL

NP 4457: 2007
1.ª e única empresa do setor cerâmico CERTIFICADA PELO SISTEMA DE GESTÃO DA INVESTIGAÇÃO, DESENVOLVIMENTO E INOVAÇÃO

NP 4457: 2007
1st and only company in the ceramic sector CERTIFIED BY RESEARCH, DEVELOPMENT AND INNOVATION MANAGEMENT SYSTEM

NP 4457: 2007
1^{re} et unique entreprise du secteur céramique CERTIFIÉE POUR SYSTÈME DE GESTION DE LA RECHERCHE, DU DÉVELOPPEMENT ET DE L'INNOVATION

NP 4457: 2007
1.ª y única empresa del sector cerámico CERTIFICADA POR EL SISTEMA DE GESTIÓN DE LA INVESTIGACIÓN, EL DESARROLLO Y LA INNOVACIÓN

Ajude-nos na nossa missão de preservar a natureza: recicle o seu catálogo usado.

Join us on our mission to protect nature: please recycle your used catalogue.

Aidez-nous dans notre mission de préservation de la nature : recyclez votre catalogue usagé.

Ayúdenos en nuestra misión de conservar la naturaleza: recicle su catálogo usado.

ÁGUEDA:

Apartado 1 · 3754-001 BARRÔ AGD · Portugal
Tel. +351 234 660 100 Fax +351 234 666 555
GPS 40.532865 N, 8.449056 W (Gândara do Vale do Grou)

LISBOA:

Pç. José Fontana 26 A-C · 1050-129 LISBOA · Portugal
Tel. +351 213 170 280 Fax +351 213 170 282
GPS 38.730144 N, 9.144978 W

Showrooms:

2^a a 6^a feira: 9.00-19.30h (Águeda: 19:00h); Sábado: 9.30-13.30h
Monday to Friday: 9.00am-7.30pm (Águeda: 7:00pm); Saturday: 9.30am-1.30pm

revigres@revigres.pt

www.revigres.com



REVIGRÈS AR APP
disponível • available

